

PART 1

CHAPTER 9—WARNING SYSTEMS AND LIGHTING

Contents

WARNING SYSTEMS

	Para
CONTROLS AND INDICATORS	1
DESCRIPTION OF THE SYSTEMS	
General	2
Standard Warning System	3
Auxiliary Warning System	11
INTERNAL LIGHTING — F MK 3 & F MK 6	
CONTROL AND INDICATORS	17
DESCRIPTION OF THE SYSTEM	
Normal Lighting	18
Emergency Lighting	22
INTERNAL LIGHTING — T MK 5	
CONTROLS AND INDICATORS	24
DESCRIPTION OF THE SYSTEM	
Normal Lighting	25
Emergency Lighting	27
EXTERNAL LIGHTING — F MK 3 & F MK 6	
CONTROLS AND INDICATORS	29
DESCRIPTION OF THE SYSTEM	30
EXTERNAL LIGHTING — T MK 5	
CONTROLS AND INDICATORS	31
DESCRIPTION OF THE SYSTEM	32
Illustrations	Fig
Warning Systems Controls and Indicators — F Mk 3 and F Mk 6	1
Warning Systems Controls and Indicators — T Mk 5	2
Standard Warning Panel — F Mk 3 and F Mk 6	3
Auxiliary Warning Panel — F Mk 3 and F Mk 6	4
Warning Panels — T Mk 5	5
Lighting Controls — F Mk 3 and F Mk 6	6
Lighting Controls — T Mk 5	7

WARNING SYSTEMS**CONTROLS AND INDICATORS**

1. The controls and indicators for the warning systems in the F Mk 3 and F Mk 6 are listed in Table 1, and

for the T Mk 5 in Table 2; illustrations are Fig 1 and 2 respectively. The standard warning panel (SWP) and auxiliary warning panel (AWP) in the F Mk 3 and F Mk 6 are shown in Fig 3 and 4. The panels in the T Mk 5 are shown in Fig 5.

Table 1 — Controls and Indicators — F Mk 3 and F Mk 6

<i>Item No</i>	<i>Item</i>	<i>Markings</i>	<i>Remarks</i>
1	Standard warning panel	See text	—
2	Fire extinguisher buttons (2) (SWP)	F1, F2	Integral fire warning lights
3	Cancel button (SWP)	C	Integral flashing light
4	Mute switch (SWP)	M	Integral light comes on when muted (up)
5	Test button (SWP)	T	Not illustrated
6	Audio mute button	AUDIO WARNING — PULL TO MUTE	—
7	Day/night screen (SWP)	DAY/NIGHT	—
8	Auxiliary warning panel	See text	—
9	Test button (AWP)	TEST	—
10	Day/night switch (AWP)	NIGHT/DAY	—
11	Mute button (AWP)	—	Not illustrated. Integral light on when muted (up)

Table 2 — Controls and Indicators — T Mk 5

<i>Item No</i>	<i>Item</i>	<i>Markings</i>	<i>Remarks</i>
1	Standard warning panel	See text	—
2	Fire extinguisher buttons (2) (SWP)	F1, F2	Integral fire warning lights
3	Cancel button (SWP)	C	Integral flashing light
4	Mute button (SWP)	M	Integral light on when muted (up)
5	Test button (SWP)	T	—
6	Audio mute button	AUDIO MUTE	Up for mute
7	Day/night screen (SWP)	See text	—
8	Auxiliary warning panel	See text	—
9	Test button (AWP)	T	—
10	Day/night screen (AWP)	—	Not illustrated. Translucent screen

DESCRIPTION OF THE SYSTEMS

General

2. The standard warning system and the auxiliary warning system ensure that malfunctions in aircraft systems are easily identified. The standard warning panel (SWP) displays captions relating to the more important failures while the auxiliary warning panel (AWP) deals with less important warnings. Audio warning and flashing attention-getters operate when an SWP caption is triggered.

Standard Warning System

3. The warnings on the SWP are ready to operate when AC and DC supplies are available, and the ENG MASTER (ENGINE MASTER, T Mk 5) and INST MASTER (INSTRUMENT MASTER, T Mk 5) switches are on. The fire captions, however, operate with the engine master switch off providing the instrument master switch is on.

4. The captions on the SWP, together with their meanings, are listed in Table 3. A fuller description

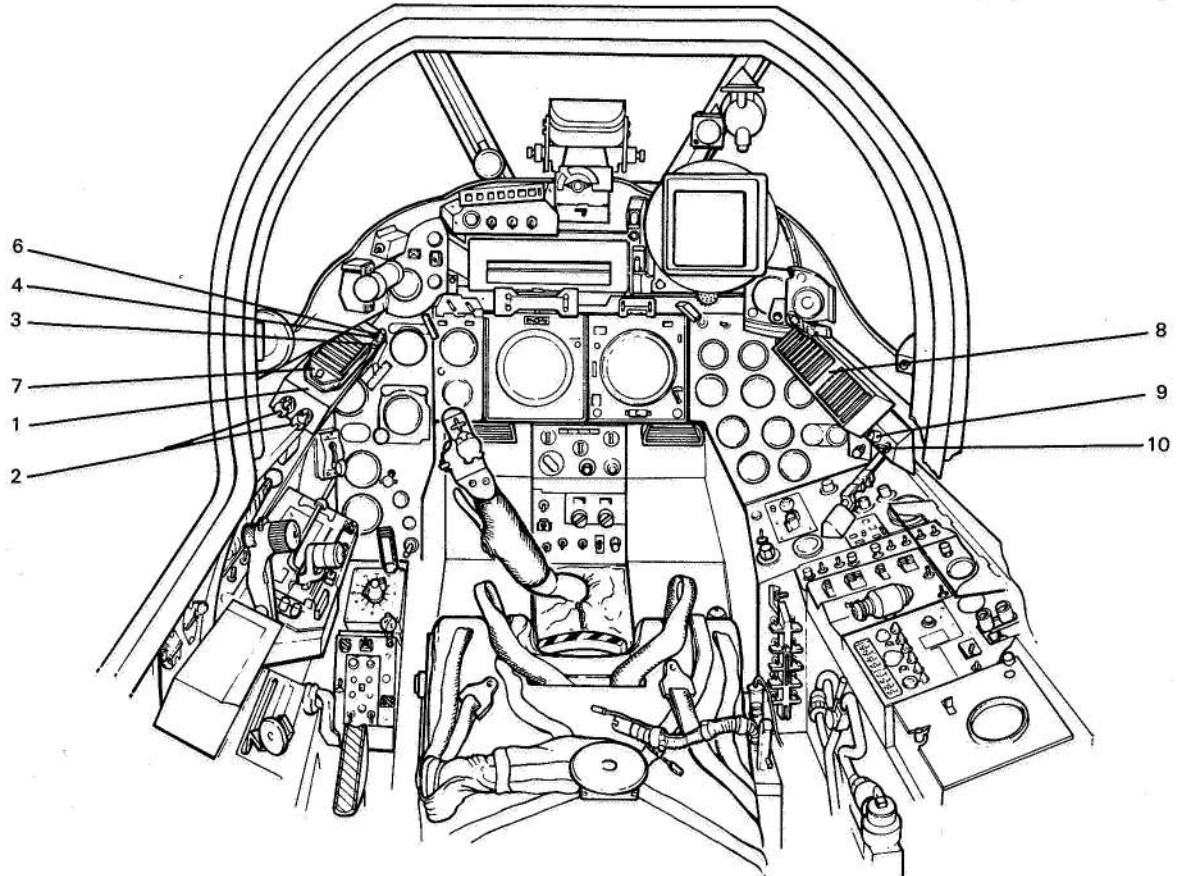

1-9 Fig 1 — Warning Systems Controls and Indicators — F Mk 3 and F Mk 6

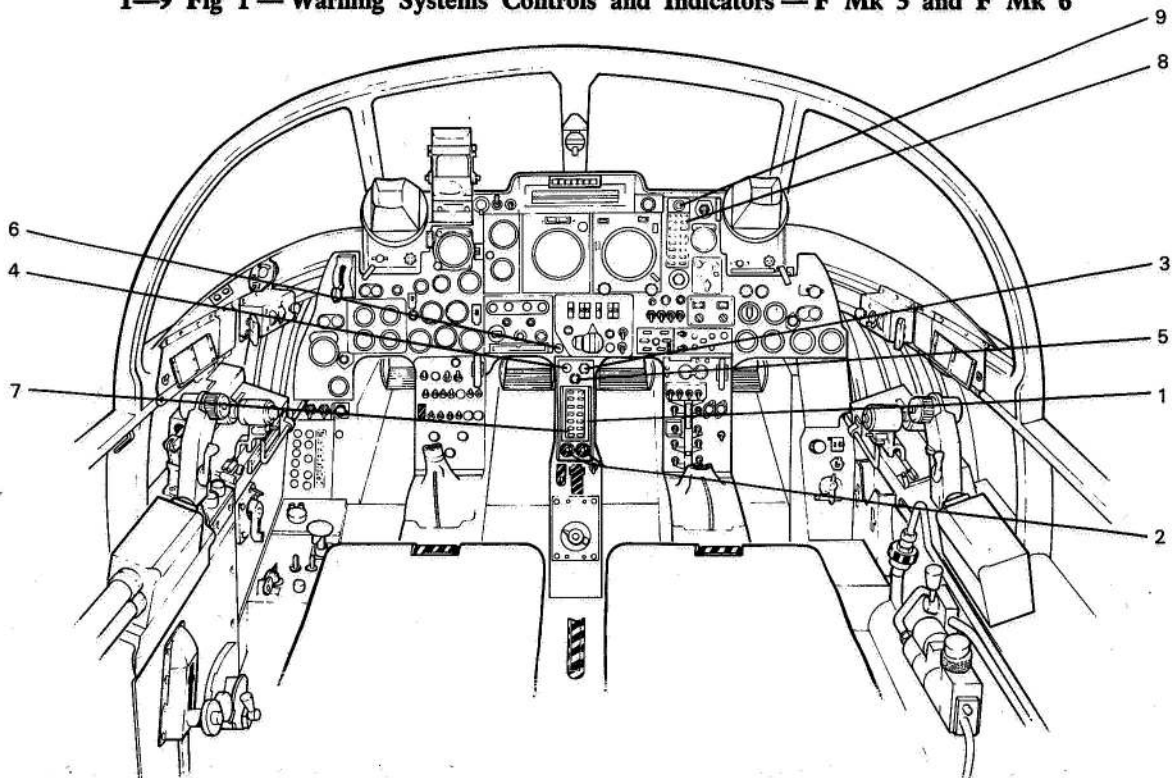

1-9 Fig 2 — Warning Systems Controls and Indicators — T Mk 5

of the cause and the associated action for each caption is given in the Chapter dealing with the appropriate system.

Table 3 — SWP Captions

Caption	Cause
FIRE 1	Fire in No 1 engine bay (zones 1 and 2)
FIRE 2	Fire in No 2 engine bay (zones 1 and 2)
RHT 1	Fire in No 1 jetpipe area (zone 3)
RHT 2	Fire in No 2 jetpipe area (zone 3)
GEN	Both generators off line
HYD	No 1 and No 2 Controls hydraulic systems failed
AP	Autopilot trip
CPR	Cockpit pressurisation failure
OXY	Oxygen supply failure (there are two OXY captions in the T Mk 5)

5. In addition to the captions, the SWP incorporates two fire extinguisher push buttons (F1/F2) which have integral lights; the appropriate light in an extinguisher button comes on when a FIRE 1 or FIRE 2 caption on the panel is lit.

6. *Attention-Getters.* When any caption on the SWP comes on, a red attention light (two lights, T Mk 5) flashes and an audio alarm is heard. If a caption comes

on and then goes out, the audio alarm and attention-getters also stop.

7. *Associated Controls.* In addition to the two fire extinguisher buttons, there are four other buttons associated with the SWP either on, or adjacent to, the panel:

a. *Cancel Button.* The spring-loaded C button has an integral light which flashes when a caption on the panel comes on. Pressing and releasing the button cancels the audio alarm, attention-getters and the flashing integral light, leaving the attention-getters ready to signify any subsequent warning. The C button does not extinguish any captions nor the lights in the fire extinguisher buttons.

b. *Mute Switch.* When the M button is pulled, its integral light comes on and all captions except the fire warnings are rendered inoperative. The M button is always to be pressed down (light out) in flight.

c. *Test Button.* Pressing the spring-loaded T button causes all captions, the F1 and F2 lights, and the audio and flashing alarms to operate. After releasing the T button, all captions go out (unless they were previously lit); the C button is pressed to cancel the audio and flashing alarms.

d. *AUDIO MUTE.* The AUDIO MUTE button, when pulled out, attenuates the audio alarm.

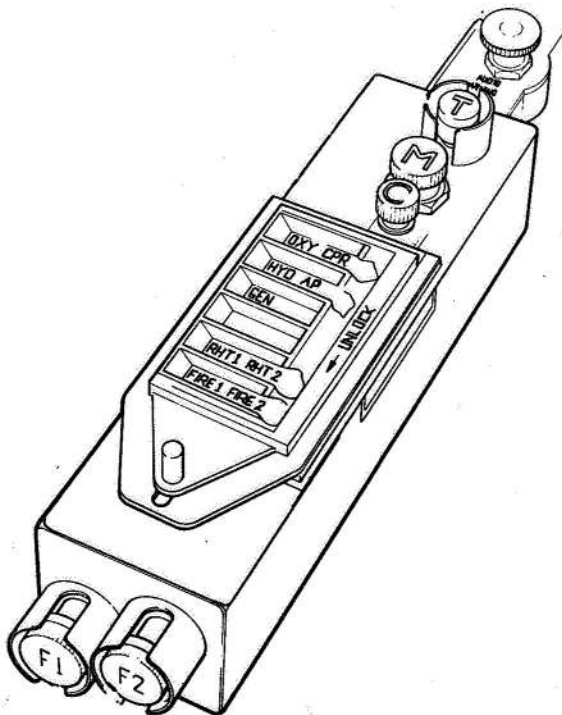

1—9 Fig 3 — Standard Warning Panel —
F Mk 3 and F Mk 6

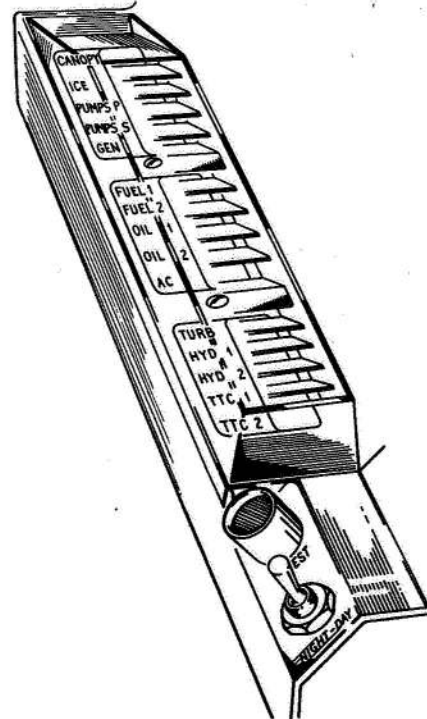

1—9 Fig 4 — Auxiliary Warning Panel —
F Mk 3 and F Mk 6

8. *Day/Night Screens.* In the F Mk 3 and F Mk 6 a screen covers the captions when the DAY/NIGHT selector is moved to NIGHT. In the T Mk 5 a translucent screen is moved over the captions for night operation.

9. *AC Changeover.* If a FIRE or RHT caption is lit and the attention-getters have been cancelled, the attention-getters are re-activated if AC changeover from alternator to inverter (or vice versa) takes place.

10. *Indications Summary.* When a warning occurs on the SWP, the following indications are given:

- Attention light(s) flashes
- Audio alarm sounds
- Caption lit
- C button light flashes

If a FIRE caption is on, the appropriate extinguisher button comes on

Auxiliary Warning System

11. The warning captions on the AWP are DC operated. There are no audio or visual attention-getters in the auxiliary warning system.

12. The single-seat aircraft have a panel different in shape from that in the T Mk 5, but both types of panel contain the same warning captions. In the F Mk 3 and F Mk 6 the panel has an 'open' list of warning captions down its left side for night use and a duplicated list of 'shuttered' captions down the right side for day use. The T Mk 5 has one set of captions for both day and night.

13. The captions on the AWP, together with their meanings, are listed in Table 4. A fuller description of the causes and the associated action for each caption is given in the Chapter dealing with the appropriate system.

Table 4 — AWP Captions

Caption	Cause
GEN	Main generator failure
TURB	Air turbine stall
AC	Alternator failure
PUMPS P	Fuel transfer pressure low (left)
PUMPS S	Fuel transfer pressure low (right)
FUEL 1	Fueldraulic pump output failure (left)
FUEL 2	Fueldraulic pump output failure (right)
OIL 1	No 1 engine oil pressure low
OIL 2	No 2 engine oil pressure low
HYD 1	No 1 Controls system failure
HYD 2	No 2 Controls system failure
TTC 1	No 1 engine reheat trip
TTC 2	No 2 engine reheat trip
CANOPY*	Canopy unlocked
ICE	Inoperative

*In the T Mk 5, the canopy warning reads CAN.

14. *Test Button.* The filaments of all the lamps are tested by pressing the spring-loaded TEST button (marked T in the T Mk 5).

15. *Day/Night Systems.* In the T Mk 5 a translucent screen is moved over the captions for night use. In the F Mk 3 and F Mk 6 a DAY/NIGHT switch is fitted. When DAY is selected, two lamps under each right-hand 'shuttered' window are in circuit; when NIGHT is selected, two lamps under each 'open' left-hand caption are in circuit:

16. *Mute Button.* In the F Mk 3 and F Mk 6, a push/pull mute button is mounted at the forward end of the AWP to prevent overheating during long periods of servicing with DC power on line. With the button pulled out an integral lamp in the switch comes on and all warnings on the AWP are extinguished. A positive check that the switch is pushed in (lamp out) is to be made prior to starting.

**INTERNAL LIGHTING — F MK 3 AND F MK 6
CONTROLS AND INDICATORS**

17. The controls and indicators for the internal lighting system for the F Mk 3 and F Mk 6 are listed in Table 5 and illustrated in Fig 6. All lighting is supplied from the DC system except for the 4-volt instrument lighting circuit which is fed, via a transformer, from the AC system.

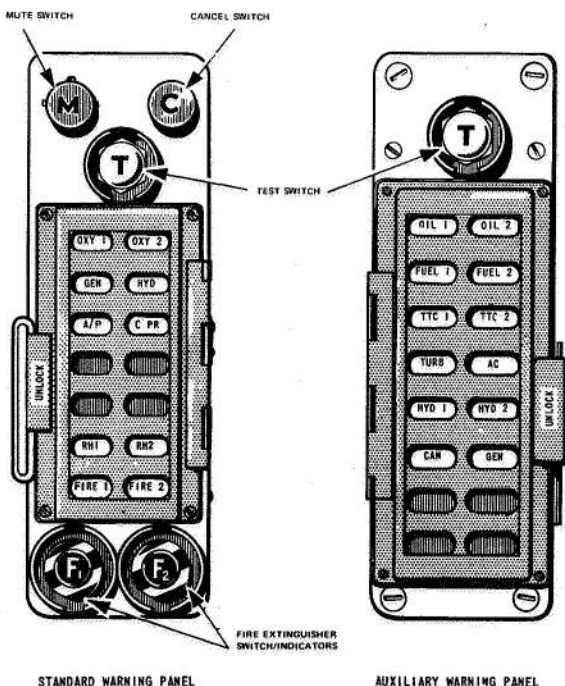

1-9 Fig 5 — Warning Panels — T Mk 5

Table 5 — Internal Lighting Controls — F Mk 3 and F Mk 6

Item No	Item	Markings	Remarks
1	Console lighting switches (2)	PORT, STBD	} Rotary dimmer switches
2	Instrument lighting switches (2)	FWD PORT, FWD STBD	
3	IFIS lighting	CENTRE	} Rotary dimmer switches
4	Standby instrument lighting	STBY E2B — ON	
5	Frequency card lighting	FREQ CARD LIGHT	—
6	Floodlamp	—	—
7	Emergency lighting switch	EMERGENCY LIGHTS — ON	—
8	Anti-dazzle lamps switch	BRIGHT/OFF/DIM	—

DESCRIPTION OF THE SYSTEM

Normal Lighting

18. The following five rotary/dimmer switches control the normal cockpit lighting:

a. *Console Lighting.* Two switches, PORT and STBD, control the pillar lamps and flood lamps for the left and right consoles respectively.

b. *Instrument Lighting.* The FWD PORT switch controls the pillar lamps and floodlamps for the left instrument and coaming panels, and the hydraulic pressure gauge. The FWD STBD switch dims the attention-getter lamp when cockpit lighting is on and controls the pillar and flood lighting in the following areas:

Right instrument panel

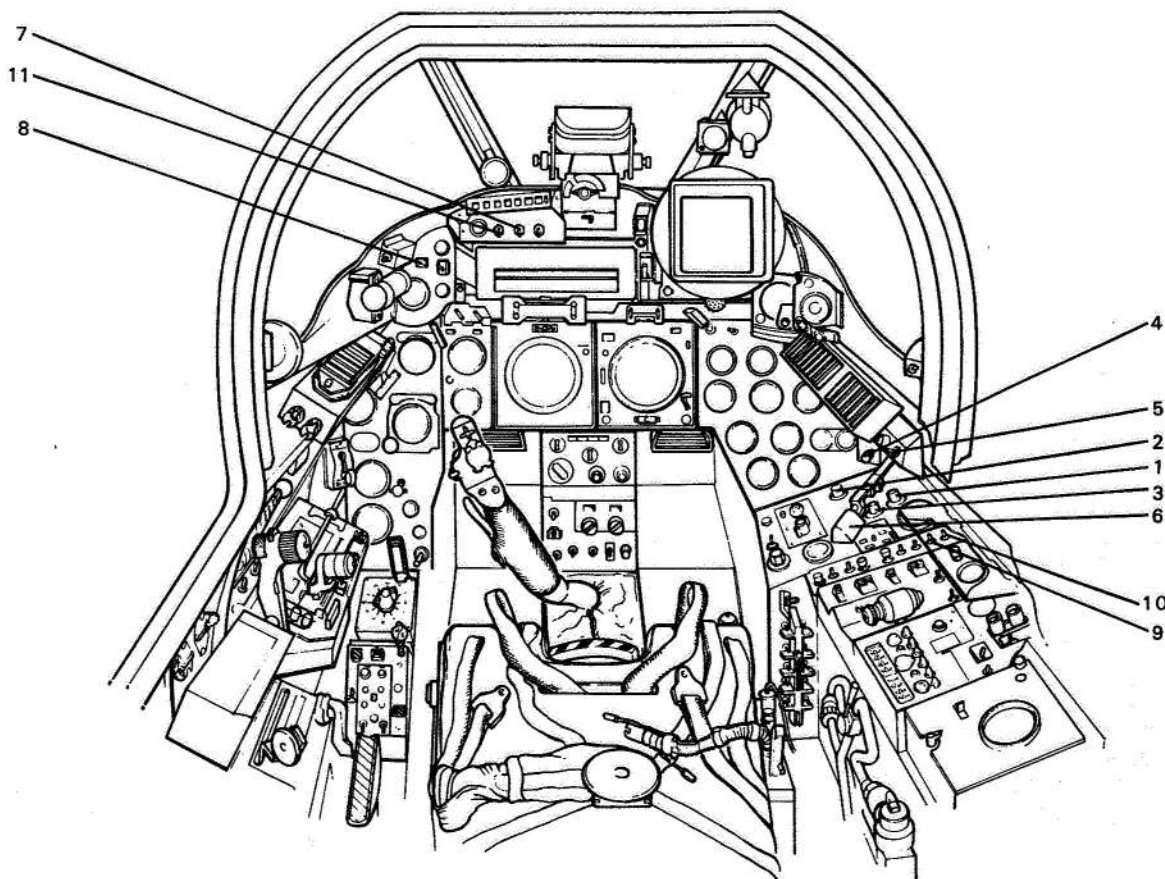

1—9 Fig 6 — Lighting Controls — F Mk 3 and F Mk 6

Starter panel
V/UHF controller
Voltmeter
Accelerometer

c. *IFIS Lighting.* The CENTRE switch controls the integral 4-volt lighting for the IFIS display.

19. *Standby Instruments.* The STBY E2B rotary dimmer switch controls the integral lamps in the standby DI and the E2B compass.

20. *Frequency Card Lighting.* The frequency card switch, marked **FREQ CARD LIGHT**, is a toggle switch which controls supplies to the frequency card lamp.

21. *Floodlamp.* A floodlamp on a swinging arm is below the AWP. The lamp, which may be used to illuminate a knee pad, is controlled by a toggle switch under the arm.

Emergency Lighting

22. If the normal cockpit lighting fails, emergency lighting is selected by switching ON the **EMERGENCY LIGHTS** switch on the left coaming panel to illuminate the instrument panel and the consoles. The electrical supply is taken from the emergency battery. With the switch at ON, the E2B compass and the standby DI lighting supply is transferred from the DC busbar to the emergency battery, but the STBY E2B switch continues to control the brilliance at these two instruments.

23. *Anti-Dazzle Lamps.* Two high-intensity white anti-dazzle lamps are fitted to the windscreen arch; they are controlled by a three-position **BRIGHT/OFF/DIM** switch on the left instrument panel.

**INTERNAL LIGHTING — T MK 5
CONTROLS AND INDICATORS**

24. The controls for the internal lighting in the T Mk 5 are listed in Table 6 and illustrated at Fig 7. All lighting is supplied from the DC system except for the 4-volt instrument circuit which is fed, via a transformer, from the AC system.

DESCRIPTION OF THE SYSTEM

Normal Lighting

25. The following five rotary dimmer switches control the normal cockpit lighting:

a. *Left Console Lighting.* A **SILL FLOODLIGHT DIM** switch on panel A2 controls the floodlamps on the left console, a bank of floodlamps on the left sill and the pillar lighting of the brake pressure gauge and voltmeter.

b. *Instrument Lighting.* Three switches on panel A3 control the instrument lighting:

(1) A **DIM PORT** switch controls a bank of floodlamps on the left sill, the engine instruments panel and standby artificial horizon pillar lamps, the **IFF/SSR** control panel, panel A3 lighting, the relight buttons and the left **100%/AIRMIX** control lighting.

(2) A **DIM STBD** switch controls one bank of floodlamps on the right sill, pillar lights on panel A1 (excluding the engine instruments), the **FCS**, **Tacan** and **E/F** band homer control units' lighting, and panels A4 and A5 lighting together with the right **100%/AIRMIX** control lighting.

(3) A **DIM CENTRE** switch controls the 4-volt instrument lighting to the **IFIS** display.

c. *Right Console Lighting.* The **SILL FLOODLIGHT DIM** switch on panel A6 controls the floodlights under the right sill.

Table 6 — Internal Lighting Controls — T Mk 5

Item No	Item	Markings	Remarks
1	Left console lighting switch	SILL FLOODLIGHT DIM	} Rotary dimmer switches
2	Instrument lighting switches (2)	DIM PORT, DIM STBD	
3	IFIS lighting switch	DIM CENTRE	
4	Right console lighting switch	SILL FLOODLIGHT DIM	} Beside frequency cards, left and right
5	Frequency card lighting switches	ON/OFF	
6	Emergency lighting switch	EMERG LIGHTS — ON	—
7	Anti-dazzle lamps switch	BRIGHT/OFF/DIM	On canopy centre member. Not illustrated

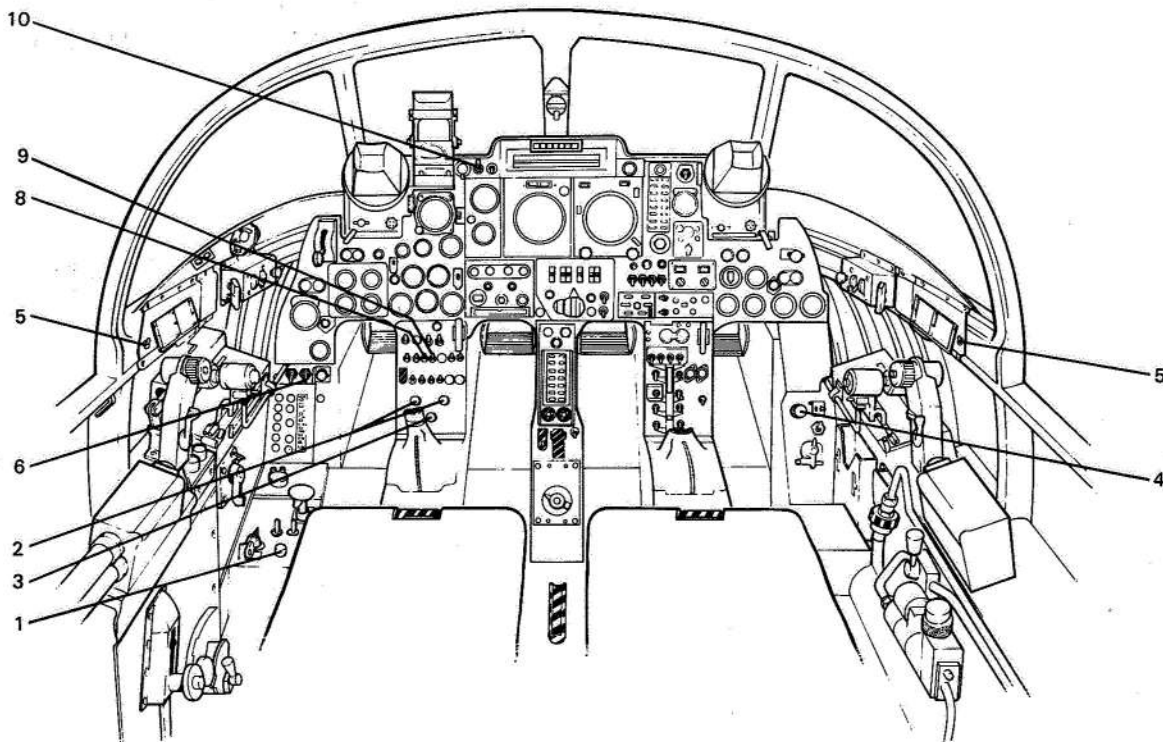

1—9 Fig 7 — Lighting Controls — T Mk 5

26. *Frequency Card Lighting.* The lighting of the frequency cards on the left and right sills is controlled by adjacent ON/OFF switches.

Emergency Lighting

27. If the normal cockpit lighting fails, emergency cockpit lighting is selected by switching ON the EMERG LIGHTS switch on panel A2 to illuminate the instrument panels and consoles. The power supply is taken from the emergency battery. With the switch ON, the E2B compass and standby DI lighting is transferred from the DC busbar to the emergency battery but the DIM PORT switch continues to control the brilliance at these two instruments.

28. *Anti-Dazzle Lamps.* Two high-intensity white anti-dazzle lamps are fitted to the canopy centre member; they are controlled by an adjacent BRIGHT/OFF/DIM switch.

EXTERNAL LIGHTING — F MK 3 AND F MK 6 CONTROLS AND INDICATORS

29. The controls for the external lights in the F Mk 3 and F Mk 6 are listed in Table 7 and illustrated in Fig 6.

DESCRIPTION OF THE SYSTEM

30. The external lighting is supplied from the 28V DC busbar. The following switches control the external lights:

- a. *Navigation Lights.* Setting the NAV LTS switch to ALL ON brings on the left, right and dual tail navigation lights together with the flashing anti-collision lights. With TIPS selected, only the navigation lights are lit.
- b. *Taxy Lights.* The two taxy lights, fitted on each main undercarriage leg, are controlled by the TAXI LTS — ON/OFF switch.

Table 7 — External Lighting Controls — F Mk 3 and F Mk 6

Item No	Item	Markings	Remarks
9	Navigation lights switch	NAV LTS — ALL ON/OFF/TIPS	—
10	Taxy lighting switch	TAXI LTS — ON/OFF	—
11	AAR probe lighting switch	PROBE LIGHT — ON	—

c. *Probe Light.* When the AAR probe is fitted, it is illuminated by selecting the PROBE LIGHT switch to ON. There is no electrical supply to the two probe lights unless the NAV LTS switch is set to ALL ON or TIPS.

EXTERNAL LIGHTING — T MK 5 CONTROLS AND INDICATORS

31. The controls for the external lights in the T Mk 5 are listed in Table 8 and illustrated on Fig 7.

DESCRIPTION OF THE SYSTEM

32. The external lighting is supplied from the 28V DC busbar. The following switches control the external lights:

a. *Navigation Lights.* The 3-position NAV LIGHT switch, when set to HI FLASH, brings on steady navigation lights and flashing anti-collision lights. When set to STEADY, only the navigation lights are lit.

b. *Taxy Lights.* Two taxy lights, one fitted on each main undercarriage leg, are controlled by the TAXI LIGHT — ON switch.

c. *Probe Lights.* When the AAR probe is fitted, it is illuminated by selecting the PROBE LIGHT switch to ON. There is no electrical supply to the two probe lights unless the NAV LIGHT switch is set to STEADY or HI FLASH.

Table 8 — External Lighting Controls — T Mk 5

<i>Item No</i>	<i>Item</i>	<i>Markings</i>	<i>Remarks</i>
8	Navigation lights switch	NAV LIGHT — STEADY/off/ HI FLASH	—
9	Taxy lighting switch	TAXI LIGHT — ON	—
10	AAR probe lighting switch	PROBE LIGHT — ON	—

RESTRICTED

Intentionally Blank

RESTRICTED

This file was downloaded
from the RTFM Library.
Link: www.scottbouch.com/rtfm
Please see site for usage terms,
and more aircraft documents.

