

PART 1

SECTION 4 — LIGHT FIGHTER SIGHT

CHAPTER 1 — LIGHT FIGHTER SIGHT

Contents

	Para
Introduction	1
Components	5
System Switching	8
Radar Ranging	9
LFS Limitations	10
Principles of Operation	11
Bulb Changing	19
 Illustrations	
LFS Sighting Head Display and Controls	1
LFS Sighting Head	2
LFS Gyro — Typical	3

Introduction

1. The light fighter sight (LFS) is a gyro compensated sighting system which presents an aiming mark to the pilot by means of a reflected image.

2. In the GUNS mode, the LFS acts as a gyro prediction sight, where deflection of the sightline is proportional to the rate of turn of the sightline and the sensitivity of the gyro. The sightline is also compensated for gravity drop and for velocity jump.

3. In the guided weapon mode, the gyro is virtually caged and acts as a fixed reflector sight. The sightline in this case is parallel to the missile line, no deflection being applied when sighting.

4. The AI can be used in conjunction with the LFS to provide radar ranging for guns and missile firing.

Components

5. The LFS system consists of a control unit Type L Mk 7, and a sighting head Type 2 Mk 5. ▶◀

6. *Control Unit.* The control unit is in the forward equipment bay; it carries out the following functions:

- a. Controls the gyro sensitivity as appropriate for the weapon to be fired.

- b. Deflects the gyro as required to position the aiming mark.

- c. Provides restraint to the gyro to prevent it toppling.

7. *Sighting Head.* The sighting head is located at eye level directly forward of the pilot (pupil only in the T5). The head contains the gyro controlled sighting system, a reflector, display components and controls, including a brightness control on the underside of the sighting head. The reflector can be folded flat when not in use. The display and controls are as follows and are shown in Fig 1:

- a. *Aiming Mark Display.* The aiming mark consists of a 'pipper' inside broken concentric circles of 8-25, 17-5 and 35 mils. Two short lines, projecting radially from both sides of the outer circle, subtend 70 mils at their extremities, and indicate the plane of the aircraft wings. Range is visually assessed by relating the span of the target to the aiming mark. On a target with a wingspan of 23 feet, the circles represent ranges of 920 yards, 460 yards, and 230 yards. In the GW mode, the aiming mark is aligned with the missile bore-sight. In a GUNS attack, the aiming mark is depressed to give a pegged range of 375 yards. This depression allows for the difference between the gun line and the missile line, and gives fixed gravity drop and velocity jump angle inputs.

b. *Event Markers Display.* Two event markers are displayed on the reflector, below the aiming mark, at the appropriate times. The left hand (A) marker indicates that one or both missiles have acquired the target and appears in response to a signal from the missile pack. The right hand marker (a circular spot of light) appears during radar ranging in response to the 'in range' signal from the AI.

c. *Airspeed Setting Control.* This control is not used, being provided to adjust the sightline in elevation to compensate for the variation in velocity jump angle of rockets which occurs when incidence changes with speed and/or altitude. The control rotates against a HIGH and LOW scale, both graduated from 250 to 500 knots. With speed set against the HIGH scale, the sight is accurate for that speed at 40,000 feet: a speed setting on the LOW scale is accurate at sea level.

d. *Brightness Control.* This controls the brightness of the aiming mark.

e. *Gunsight Caging.* In an LFS GUNS attack, the aiming mark is caged to the existing depression angle whenever the GS CAGE button on the control column is depressed.

System Switching

8. The LFS runs up and the display illuminates whenever the MAS is selected away from the OFF position. With CRT selected on the LFS/CRT

switch, the LFS runs up into a 'standby' condition; on selection of LFS on the LFS/CRT switch, manual missile firing circuits are made, radar ranging becomes operative, and the acquisition (A) light circuit is activated. ▶◀

Note: To return the AI to the normal search mode after operating the LFS, it is only necessary to select the LFS/CRT switch back to CRT.

Radar Ranging

9. a. *Missiles.* This facility becomes effective on selection of LFS on the LFS/CRT switch and GW on the MAS. The AI scanner is programmed to the missile boresight and a preset range gate sweeps between 5000 and 10,000 feet at altitudes above 15,000 feet and between 3000 and 6000 feet at altitudes below 15,000 feet. The LFS 'in range' marker lamp illuminates whenever a target is seen within the gate. The AI does not lock on and the lamp remains illuminated for as long as a target remains within the sweep.

b. *Guns.* This facility becomes effective on selection of LFS on the LFS/CRT switch and GUNS on the MAS. The AI scanner is programmed to the guns boresight position 1.9° below the missile boresight. A preset range gate is generated between 1350 feet and 500 feet in range. The LFS 'in range' marker lamp illuminates whenever a target is seen within this gate.

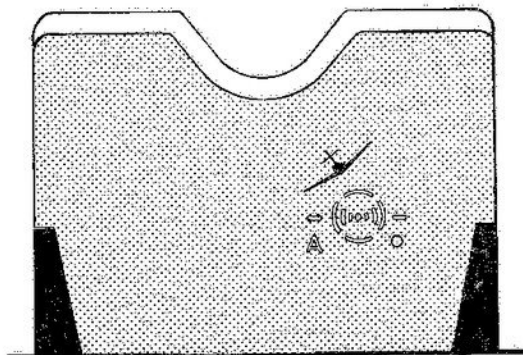

DISPLAY

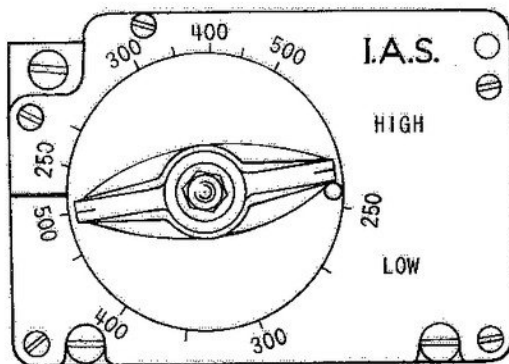

AIRSPEED SETTING CONTROL AND SCALES

1-4-1 Fig 1 LFS Sighting Head Display and Controls

LFS Limitations

10. The limitations in the use of the system are as follows:

- a. The gyro is fully run up within one minute of switching on.
- b. In a GUNS attack, the maximum deflection of the sightline is 12° from its central position. If 12° is exceeded, the anti-topple circuit is energised and the gyro returns to its central position.

Principles of Operation

11. The LFS operates as a lead computing gyro sight in accordance with the principles of operation described fully in AP 112E-0310-1A, Section 1. The sight head is depicted in Fig 2 and the gyro in Fig 3. The following explanation of LFS operation may be better understood by reference to AP 112E-0309-1. Note that the temperature and azimuth coils in Fig 3 are not used in this application.

12. In the GW mode the sensitivity coil voltage is adjusted to provide a sensitivity of 0.25 secs, and

no voltage is applied to the elevation coils. In effect the LFS provides a pure pursuit aiming index.

13. In the GUNS mode the voltage applied to the sensitivity coil is adjusted to give a sensitivity which is determined to approximate to fixed firing parameters corresponding with a range of 375 yards.

14. In any GUNS attack the sightline must be corrected for the following variables:

- a. Target motion.
- b. Gravity drop.
- c. Velocity jump.

15. *Target Motion.* Lead for target motion is required to aim the guns ahead of the target at a position in space corresponding to the predicted target position at bullet impact. The angular correction for this factor is normally the largest sightline correction and is determined by the following formula:

$$\frac{\text{Target crossing speed} \times \text{Bullet time of flight}}{\text{Range}}$$

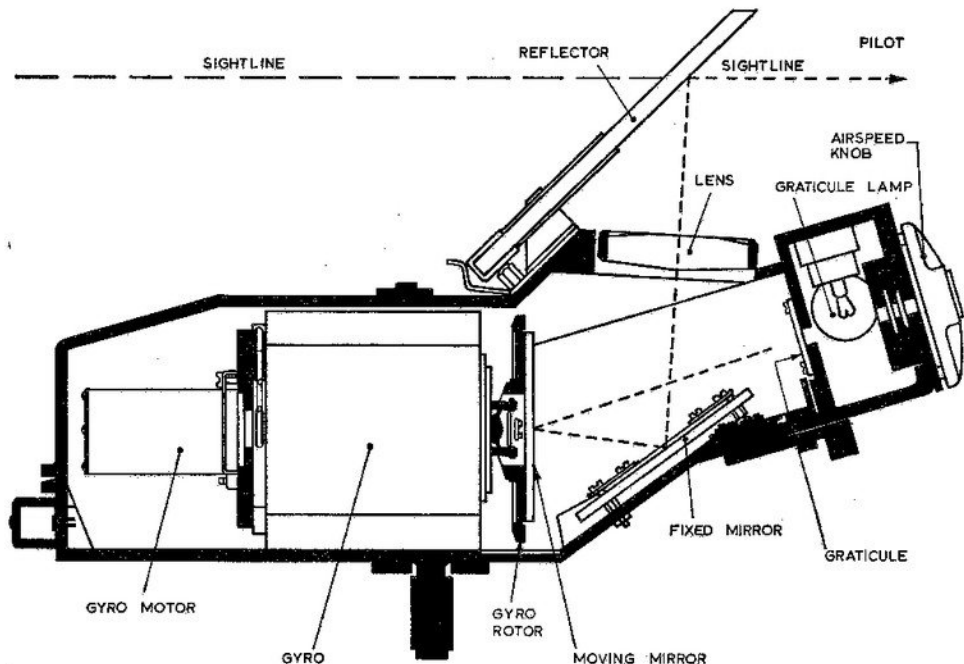

1-4-1 Fig 2 LFS Sighting Head

RESTRICTED

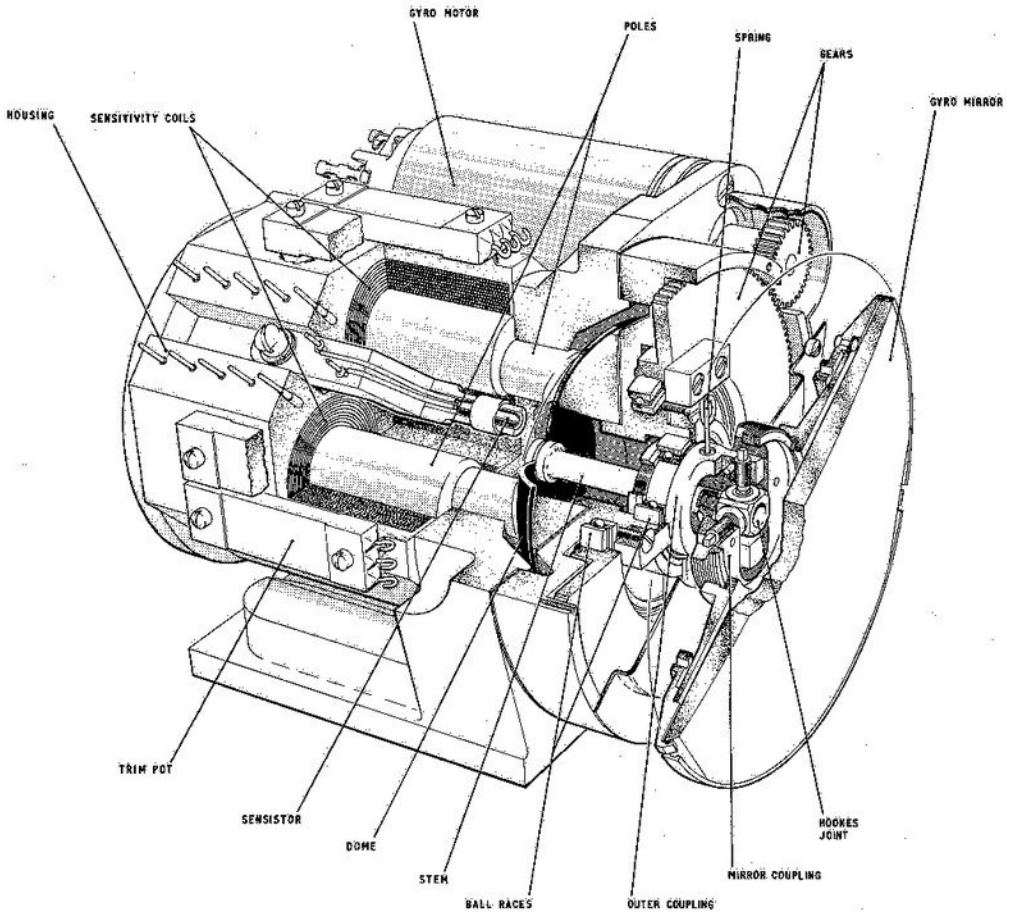

1-4-1 Fig 3 LFS Gyro - Typical

RESTRICTED

◀ Target crossing speed is sensed by the rate of turn required to track the target, which is in effect the rate of precession of the gyro. A fixed voltage is applied to the sensitivity coils to equate to a range of 375 yards. The following parameters are fixed (known values in brackets):

- a. Range (375 yards).
- b. Closing speed.
- c. Firing airspeed (IAS) (350 knots).
- d. Firing altitude (5,000 feet).

Note: The sensitivity coil voltage may be adjusted at first line servicing.

16. *Gravity Drop.* In a GUNS attack the vertical drop of the bullets due to the effect of gravity is expressed as $32.2 \times$ bullet time of flight. In the LFS a fixed voltage is applied to the elevation coils to provide the required vertical shift of the sightline to compensate for this factor. However, the elevation coils are positioned in a plane perpendicular to the plane of the aircraft wings, which results in an error when firing with bank applied.

17. *Velocity Jump.* Any angular difference between the muzzle velocity vector and the velocity vector of the aircraft will result in the bullets following the resultant of the two vectors. At low angles of attack this factor is not normally large; however, at high aircraft angles of attack this factor is significant and must be allowed for in the sighting

solution. The plane of correction is perpendicular to the plane of the aircraft wings and is therefore in the same plane as the corrections provided by the elevation coils. The fixed voltage applied to the elevation coils may therefore provide a fixed correction for velocity jump; however, it is not possible to compensate for variations in g loading by this method. It should be noted that the deflection provided by the elevation coils is proportional to the restraining effect provided by the sensitivity coil, thus any applied correction for velocity jump will be valid only at fixed values of the following parameters (known values in brackets):

- a. Angle of attack.
- b. Firing airspeed (TAS) (375 knots).
- c. Range (375 yards).

18. *Parallax.* A further fixed sightline correction is required to compensate for the vertical displacement of the sight head from the gun barrels. The numerical value of this correction is small and is applied by the elevation coils. ▶

Bulb Changing

19. Access to the LFS bulb is by raising the hinged upper cover of the sight head to which the bulb is attached. The cover is raised by applying upward pressure at the projecting screw which is positioned above the HIGH - 300 knots mark.

RESTRICTED

Intentionally Blank

RESTRICTED

This file was downloaded
from the RTFM Library.

Link: www.scottbouch.com/rtfm

Please see site for usage terms,
and more aircraft documents.

