



RESTRICTED

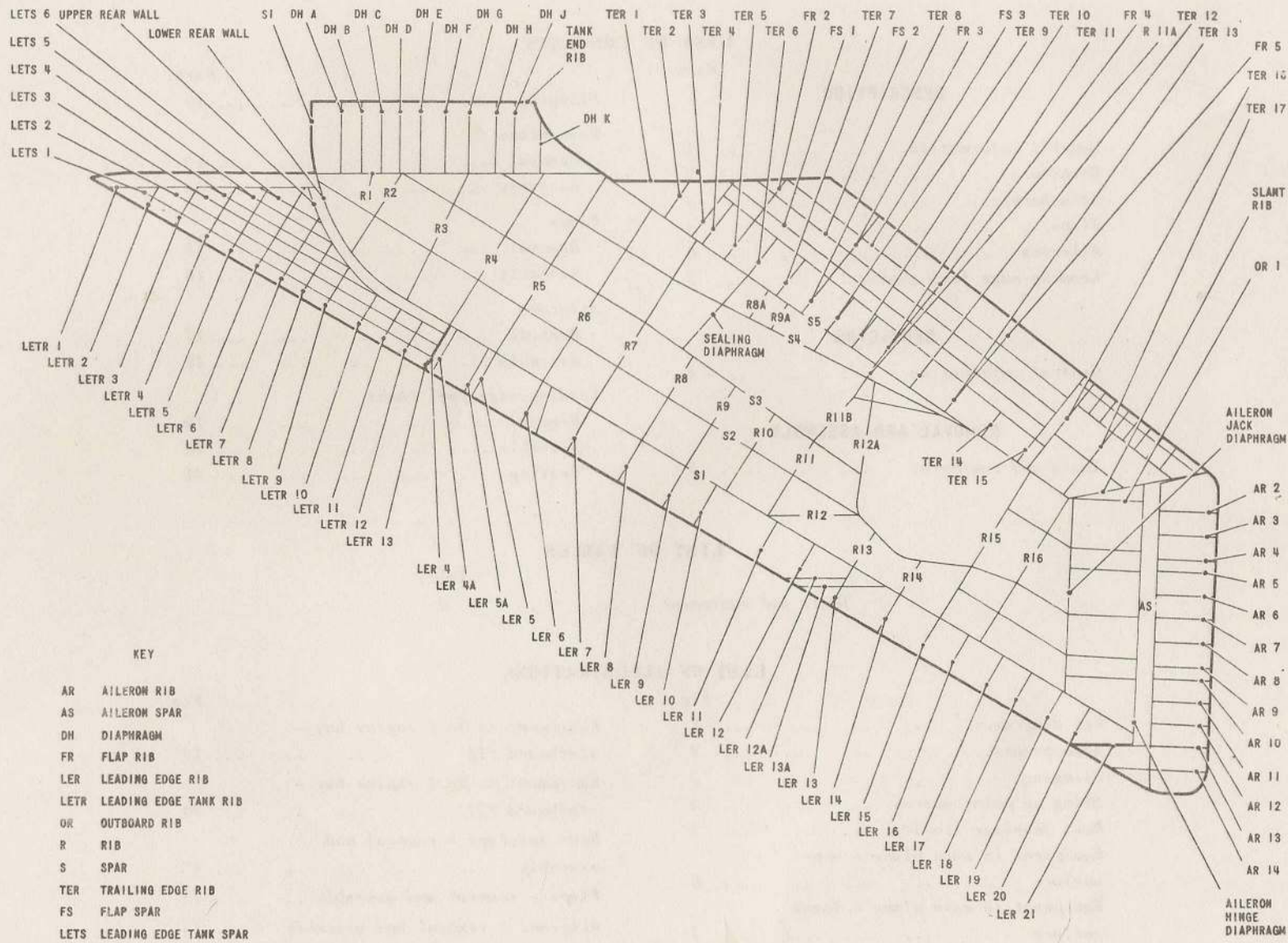

FIG.1. KEY DIAGRAM

RESTRICTED

## DESCRIPTION

## General information

1. The port and starboard main planes are constructed separately but are assembled to the rear fuselage as one unit prior to final assembly of the front and rear fuselages. The unit is accommodated in two slots extending from frames 25 to 42 in the rear fuselage; the section inside the fuselage divides No.1 engine bay from No.2 engine air duct. The leading-edge fuel tanks, leading-edge fairings, ailerons, flap shrouds, plain flaps and the main undercarriage, are added after assembly of the main planes to the fuselage.

## Structure (fig.1)

2. The basic structure of each main plane comprises five longitudinal spars, sixteen transverse ribs and a number of spanwise diaphragms, the whole being covered with heavy-gauge light-alloy skins, incorporating two longitudinal stiffeners between each spar. The section of each main plane bounded by the tank end rib, spars 1 and 5, rib 12 and part of rib 12A, the outboard section of spar 3, the sealing diaphragm and the top and bottom skins, form a sealed integral fuel tank. A number of detachable panels in spars 1 and 5 (fig.15) and the tank top skin provide access to internal components of the tank; certain of the panels are sealed with circular-section bonded rubber and the remainder are sealed with nylon thread. Two diaphragms outboard of rib 16 carry the aileron powered flying-control units (p.f.c.u.) and the aileron hinge brackets respectively. Trailing-edge ribs secured

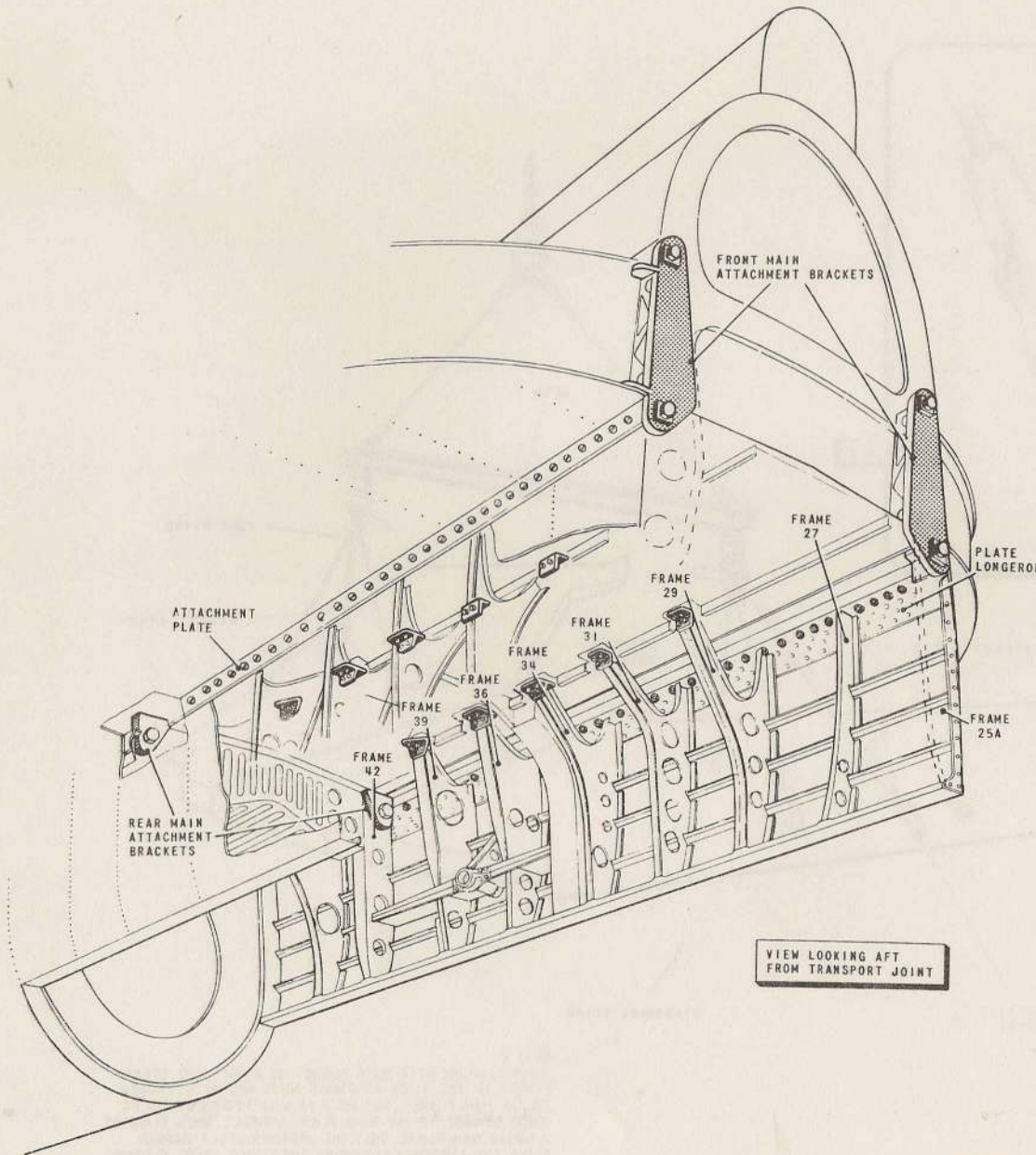

2A-8302-1

Fig.2. Attachments

RESTRICTED

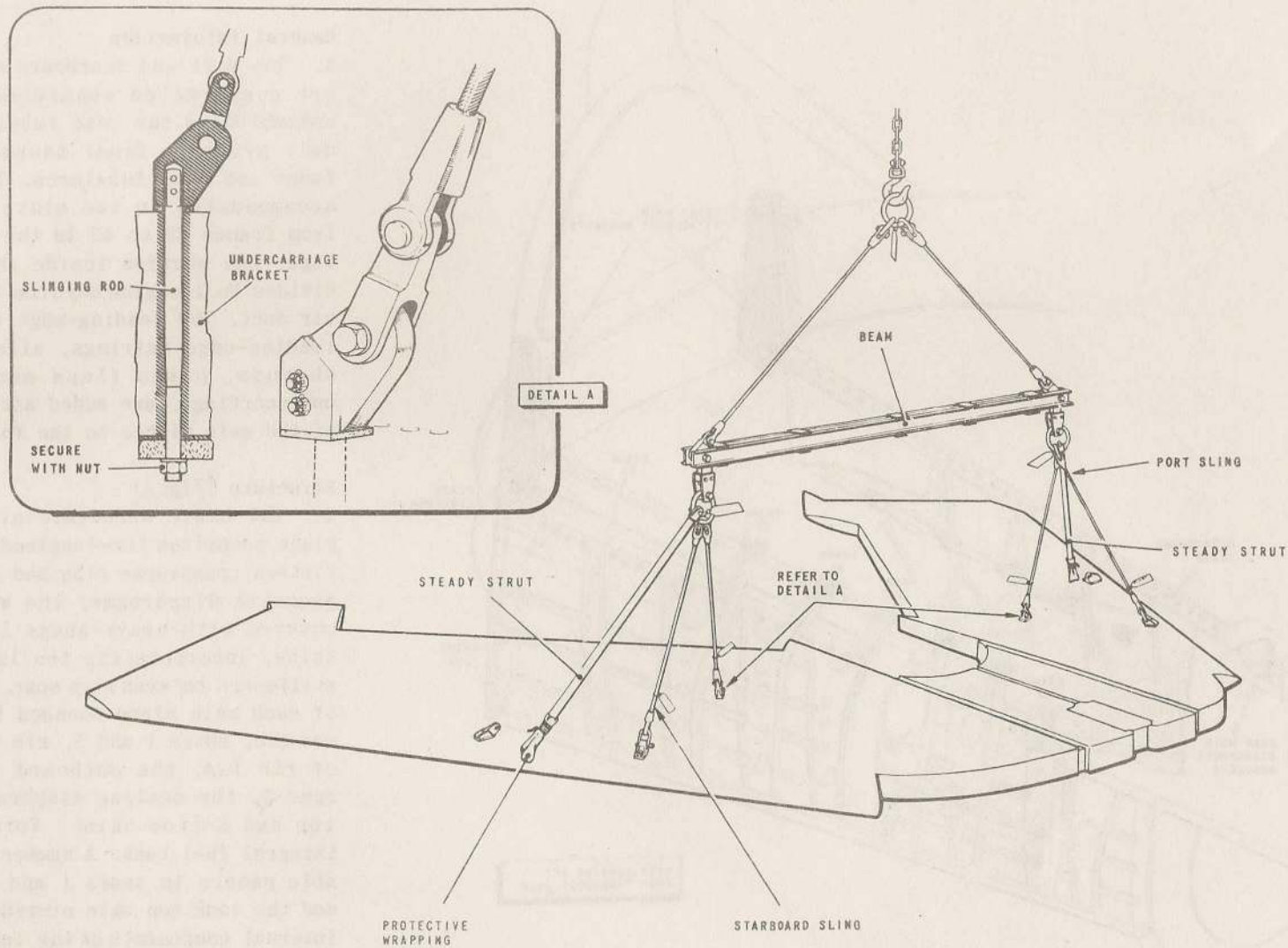

NOTE 1...  
THE AILERONS, FLAPS, MAIN-UNDER-CARRIAGE  
AND LEADING-EDGE TANKS, ARE REMOVED  
BEFORE SLINGING

NOTE 2...  
WHEN SLINGING BOTH MAIN PLANES AS A UNIT, THE STEADY  
STRUTS OF THE SLING ASSEMBLY MUST NOT BE ATTACHED  
TO THE MAIN PLANES, BUT MUST BE WRAPPED AS SHOWN TO  
AVOID DAMAGE TO THE MAIN-PLANE SURFACE. WHEN SLINGING  
A SINGLE MAIN-PLANE, ONLY THE APPROPRIATELY-HANDED  
SLING SUB-ASSEMBLY, INCLUDING THE STEADY STRUT IS USED

FIG. 3. SLINGING

◀ NOTE 1 REVISED ▶

RESTRICTED

to spar 5 support the flap shrouds and the skins between the flap and aileron. The leading-edge ribs are all part of the leading-edge fairings, with the exception of rib 16 which is secured to spar 1. A cavity formed in the structure aft and outboard of the tank houses the outward-retracting main undercarriage; after retraction, the aperture is closed by leg fairings and a door which is hinged to rib 12A and spar 4. Structural illustrations may be found in A.P.101B-1000-6.

#### Attachments (fig.2)

3. The main planes are secured to fuselage frames 25A, 29, 31, 34, 36, 39, and 42 by brackets built on to the main

plane, the primary attachments are through large brackets secured to spars 1 and 5 and bolted to frames 25A and 42. Four angled attachment plates, disposed chordwise at positions corresponding to the wing roots, are bolted to plate longerons extending along each side of the fuselage slots.

#### Flaps

4. Each flap is manufactured in two sub-assemblies which are joined together to form one unit. Each sub-assembly comprises a three-spar structure with transverse ribs, which is covered with a light-alloy stressed skin strengthened with longitudinal stiffeners. The structure is sealed to form a fuel container;

the two sub-assemblies are interconnected by pipes to permit fuel flow.

5. Hinge pins, one at each extremity and one in the mid-position, carry brackets which are bolted to trailing-edge ribs 4, 16 and 11 respectively, to secure the flaps to the main planes. The flap hinge line is set below the chord line, to ensure the minimum gap between the main-plane bottom skin and the flap leading-edge in all flap positions. The hinge pins at each end of the flaps are hollow and contain seals through which are inserted fuel and air adapters. The flap-operating jacks are connected to the end hinges.

#### Ailerons

6. The ailerons are of conventional construction, with the exception of the aluminium honeycomb tip, and are supported by five hinges, numbered 1 to 5 commencing with the inboard hinge, secured to the aileron hinge diaphragm. Mass-balance weights are incorporated at two positions, that at the outboard position forming the tip of the aileron horn. The aileron-operating mechanism is secured at hinges 2 and 4.

#### Leading-edge fuel tanks (fig.15)

7. The tanks are shaped to match the leading-edge contour and extend from leading-edge rib 13. The internal structure is based on a shear wall, at the aft side, with a number of ribs attached; these are covered with stiffened stressed skins which extend beyond the shear wall to form a cavity between wing spar 1 and the shear web, when the tank is

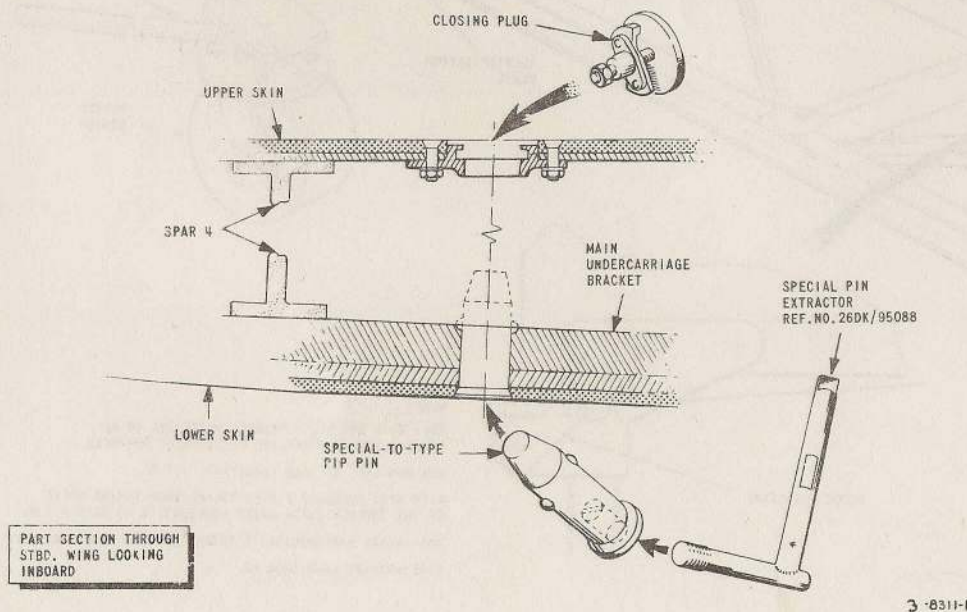
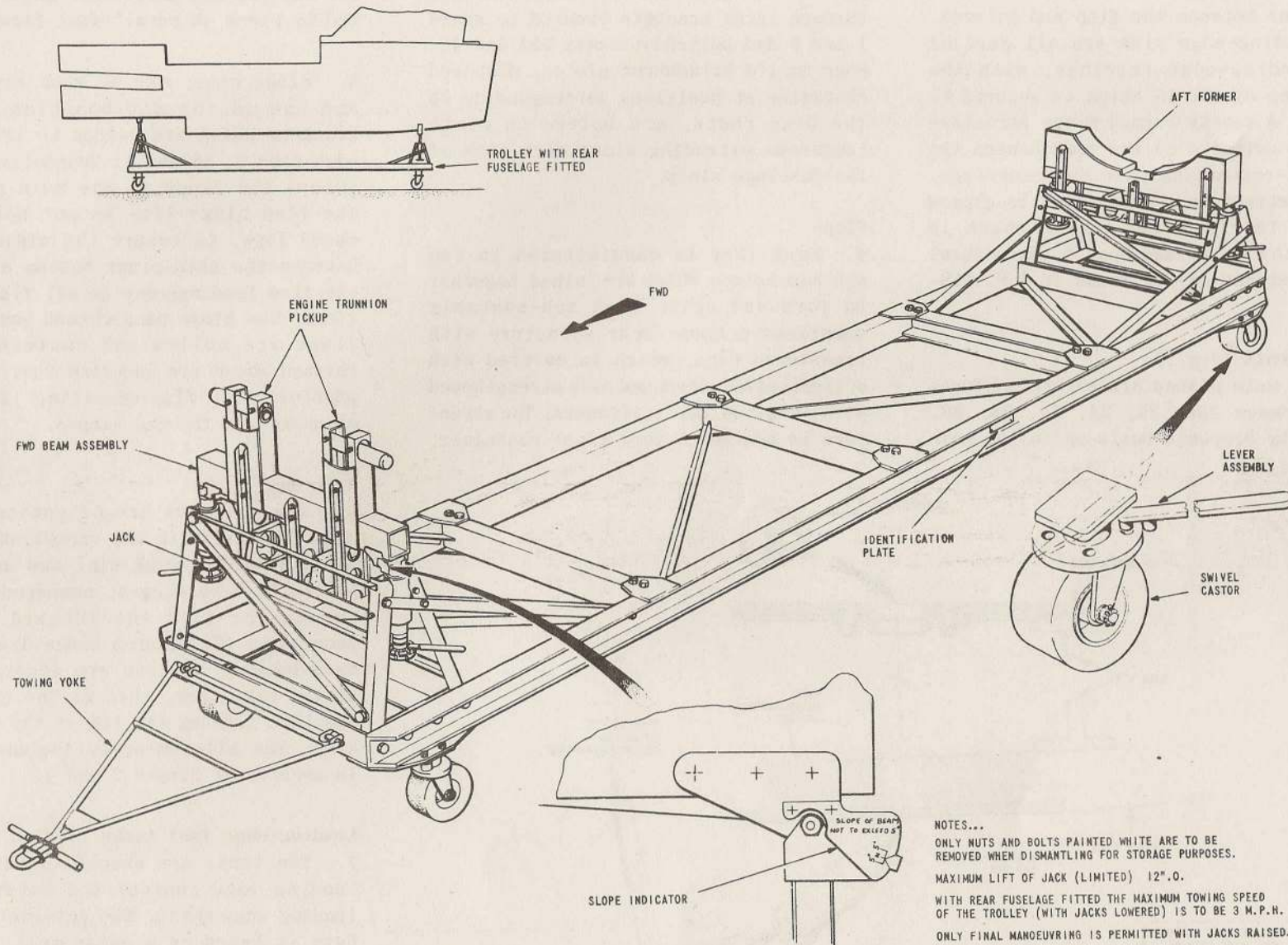

Fig.4. Slinging point access

RESTRICTED



NOTES...  
ONLY NUTS AND BOLTS PAINTED WHITE ARE TO BE REMOVED WHEN DISMANTLING FOR STORAGE PURPOSES.  
MAXIMUM LIFT OF JACK (LIMITED) 12".0.  
WITH REAR FUSELAGE FITTED THE MAXIMUM TOWING SPEED OF THE TROLLEY (WITH JACKS LOWERED) IS TO BE 3 M.P.H.  
ONLY FINAL MANOEUVRING IS PERMITTED WITH JACKS RAISED.  
SAFE WORKING LOAD 5000 LB.

FIG. 5. REAR FUSELAGE TROLLEY

3-8309-1

RESTRICTED

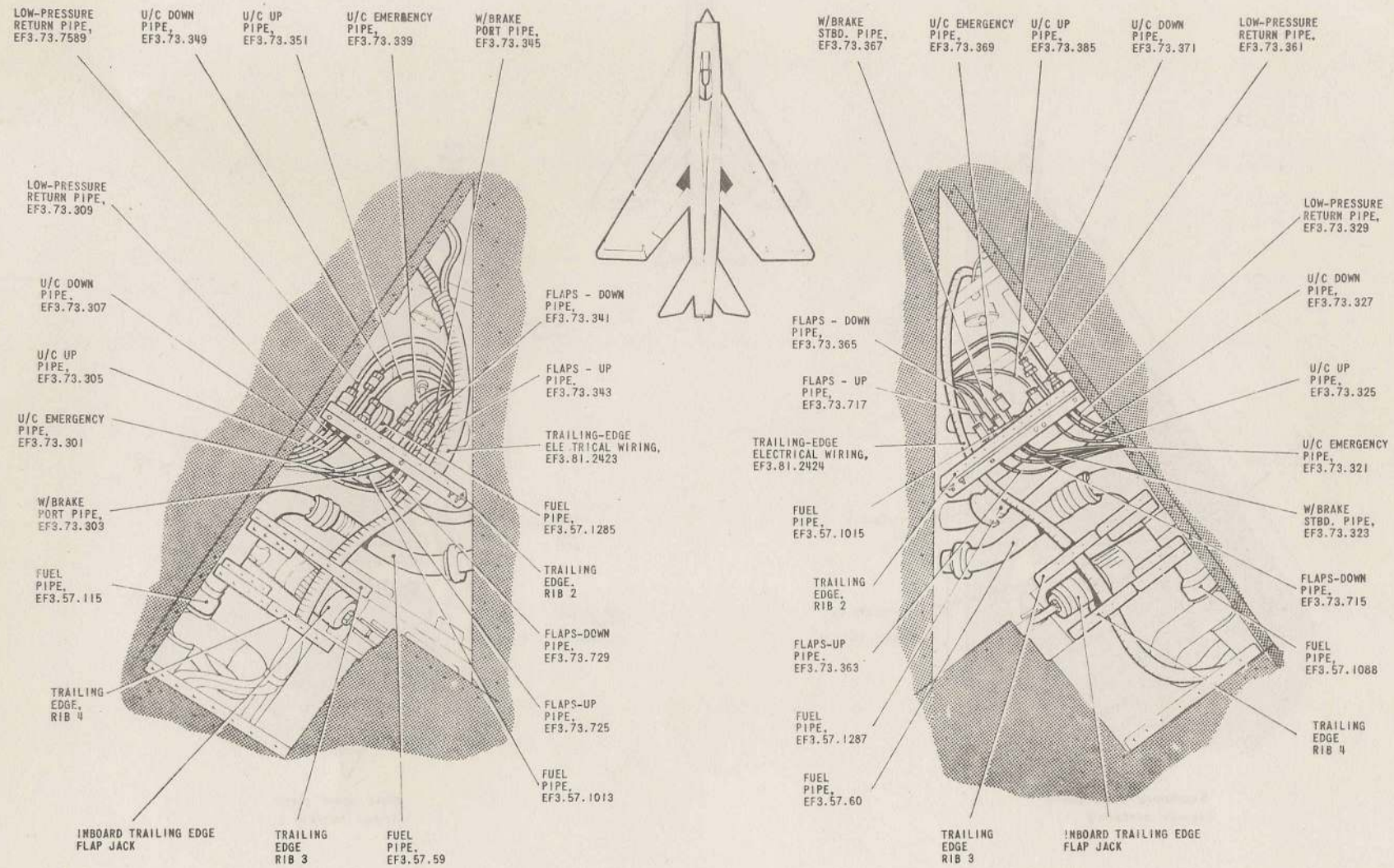

FIG. 6. EQUIPMENT IN MAIN PLANE - UPPER SURFACE

RESTRICTED

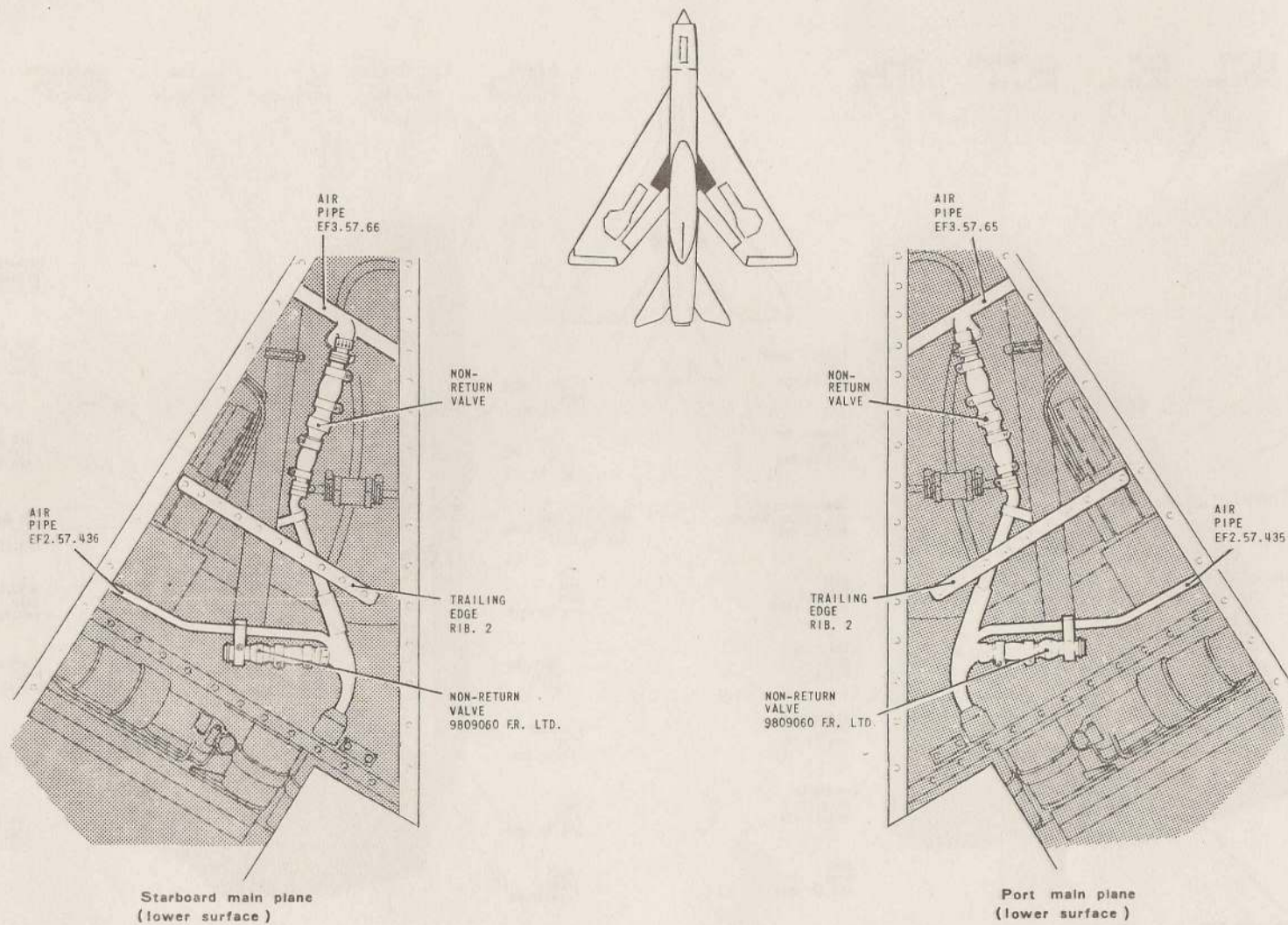

FIG. 7. EQUIPMENT IN MAIN-PLANE — LOWER SURFACE

3-8317-1

RESTRICTED

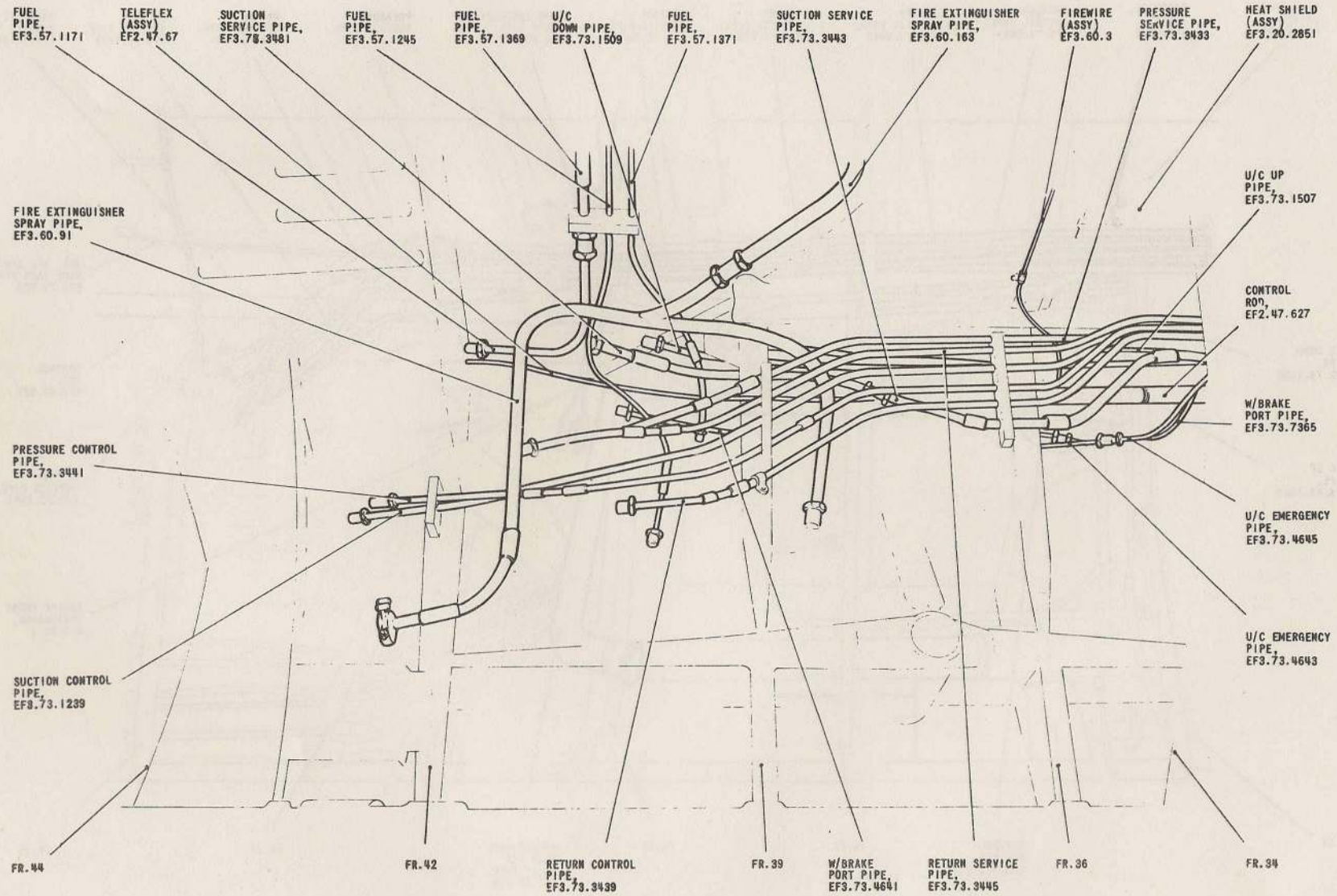

FIG. 8. EQUIPMENT IN NO.1 ENGINE BAY-PORT (1)

RESTRICTED

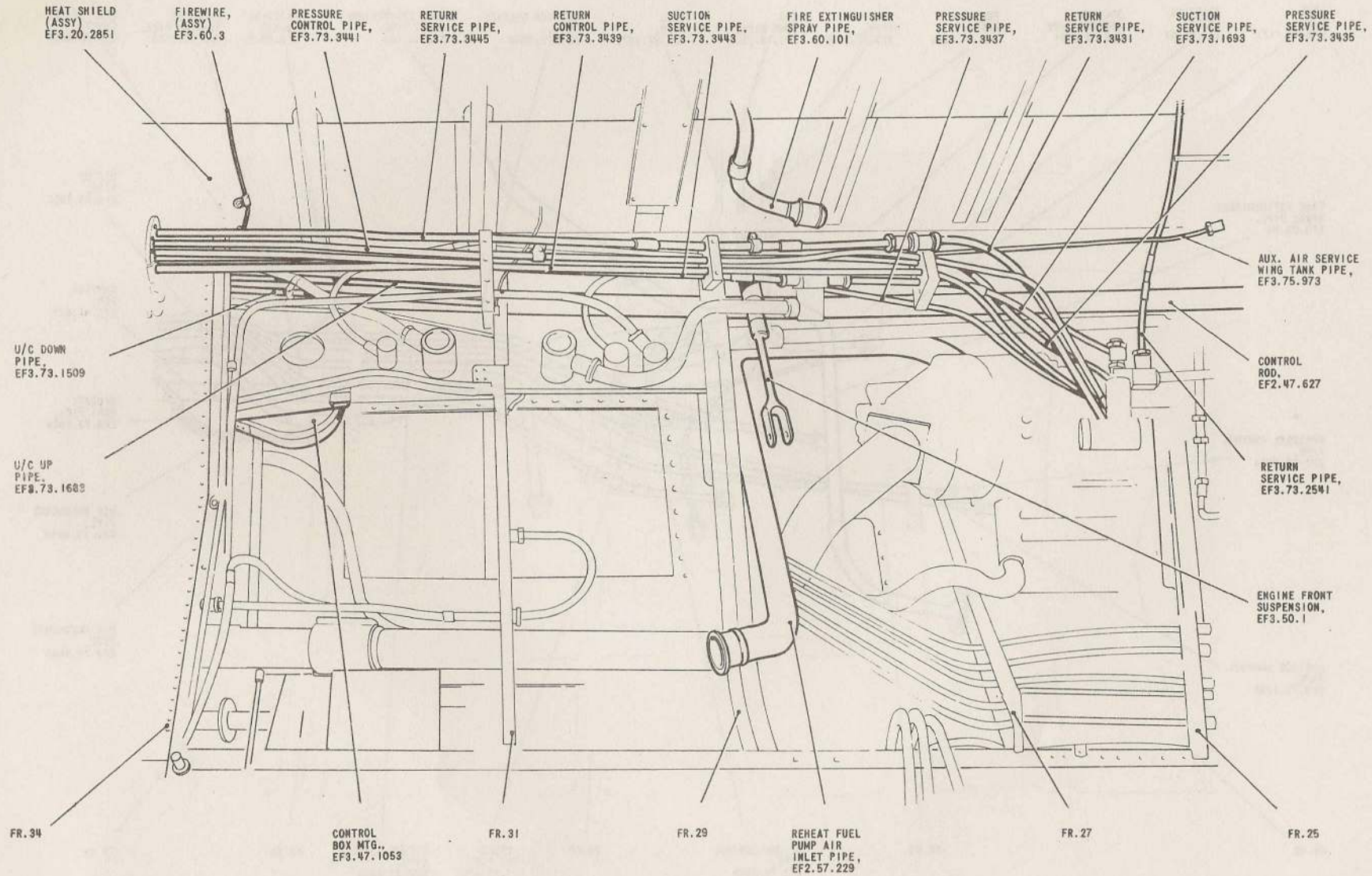

FIG. 9. EQUIPMENT IN NO.1 ENGINE BAY - PORT (2)

3-8313-1

RESTRICTED

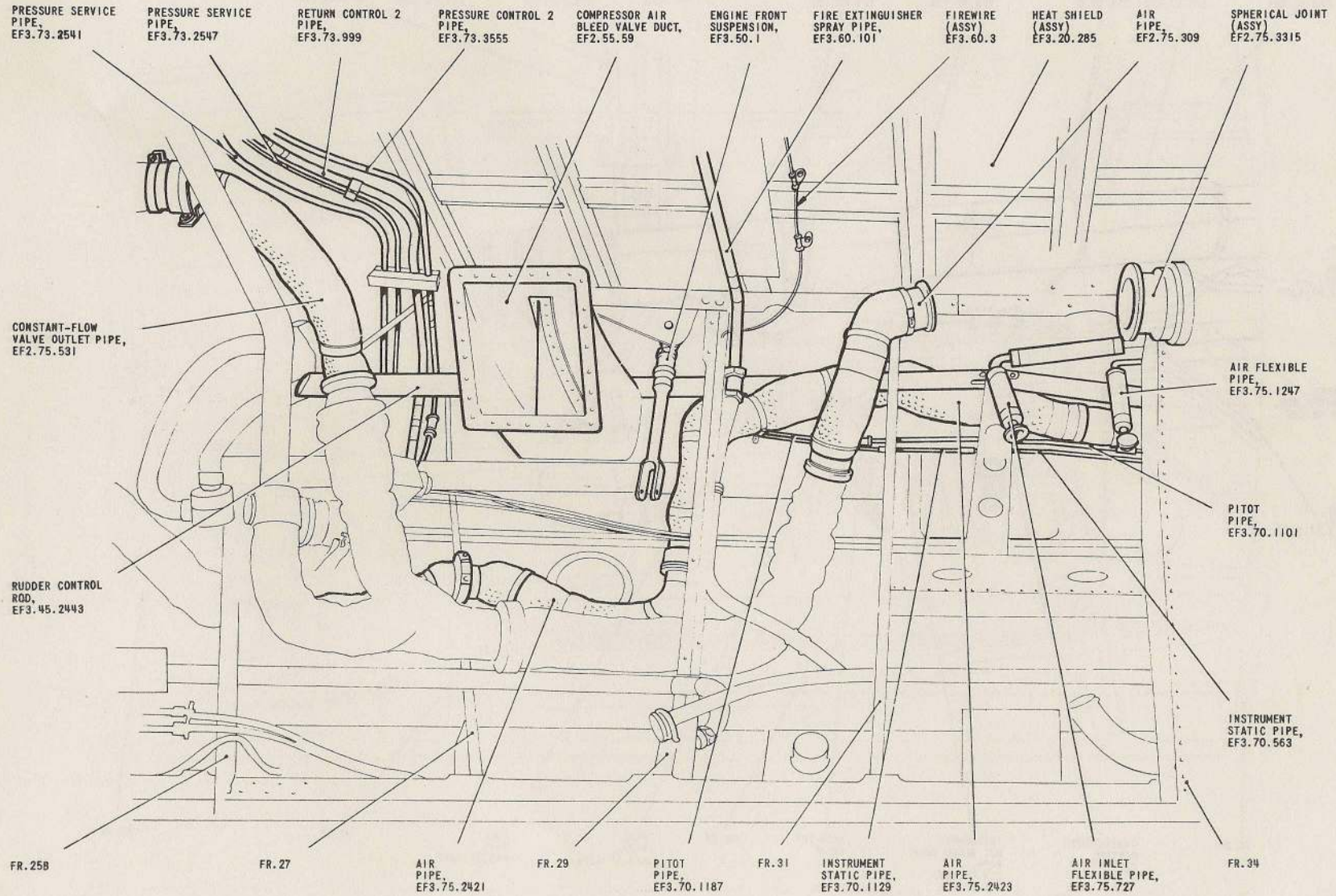

FIG. 10. EQUIPMENT IN No.1 ENGINE BAY - STARBOARD (1)

RESTRICTED

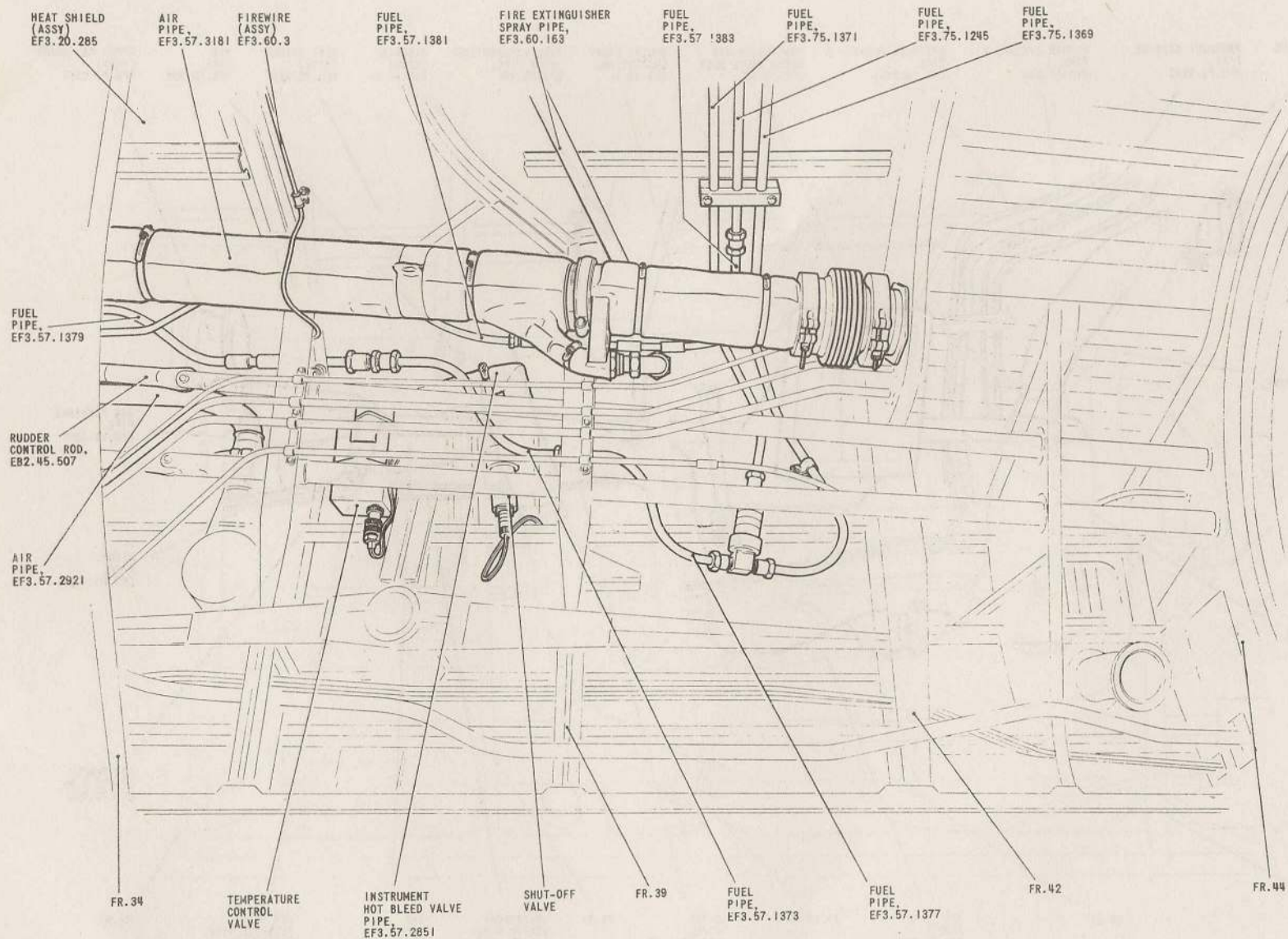

FIG. 11. EQUIPMENT IN NO.1. ENGINE BAY-STARBOARD (2)

3-8315-1

RESTRICTED

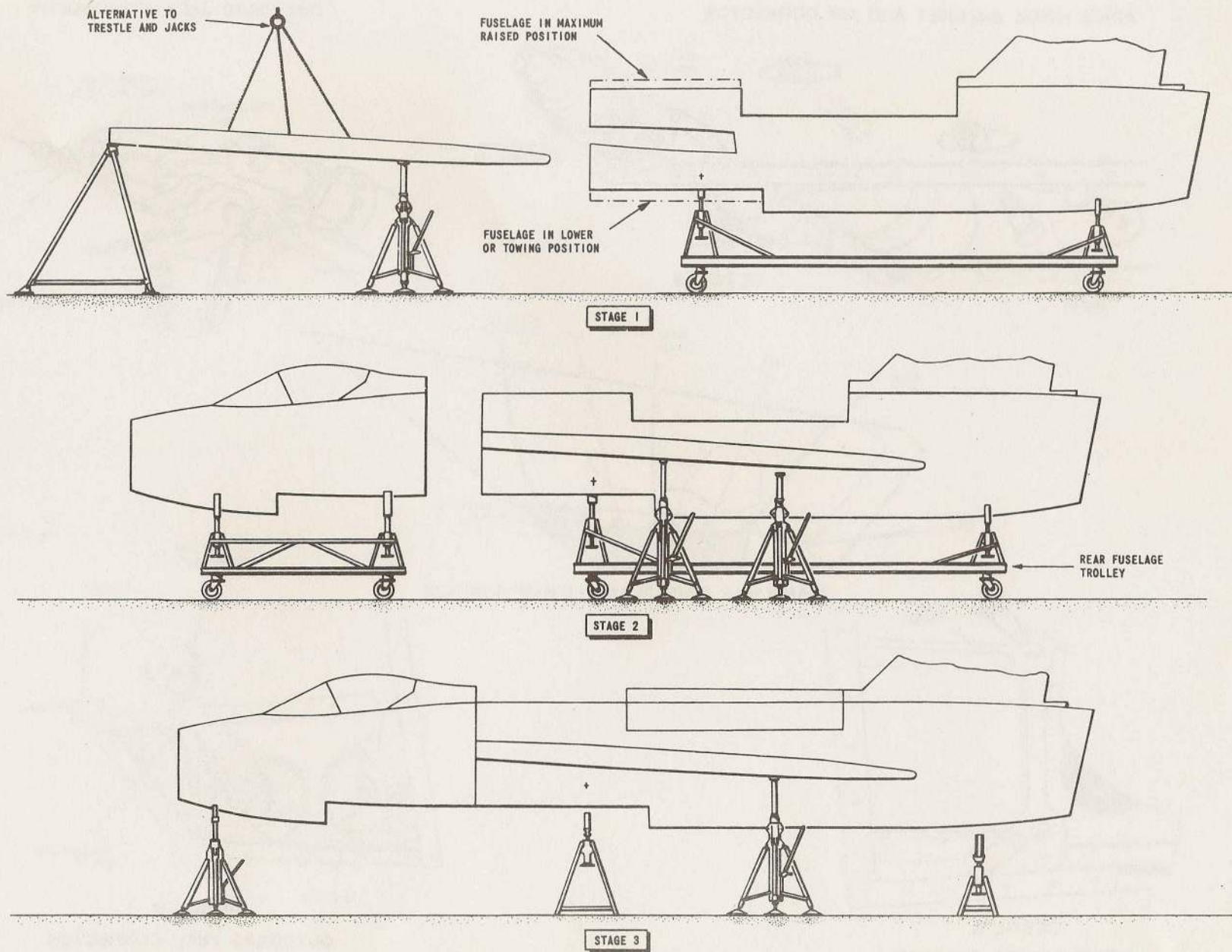
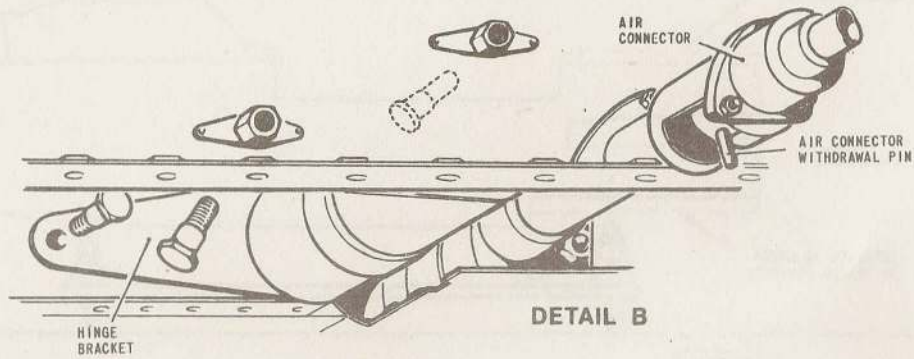

FIG.12. REAR FUSELAGE-REMOVAL AND ASSEMBLY

RESTRICTED

INNER HINGE BRACKET AND AIR CONNECTOR



OUTBOARD JACK ATTACHMENT

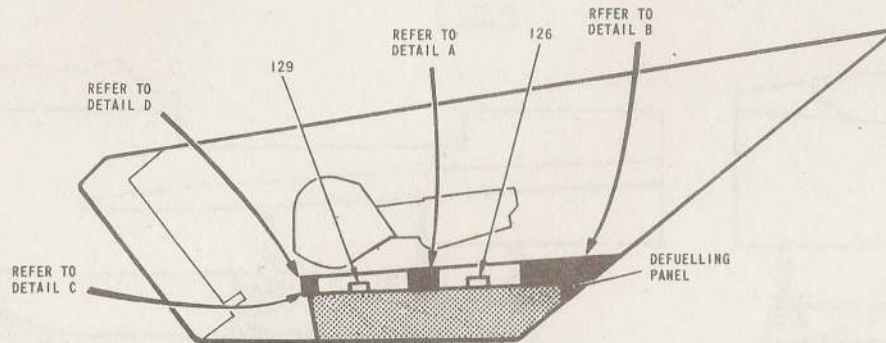
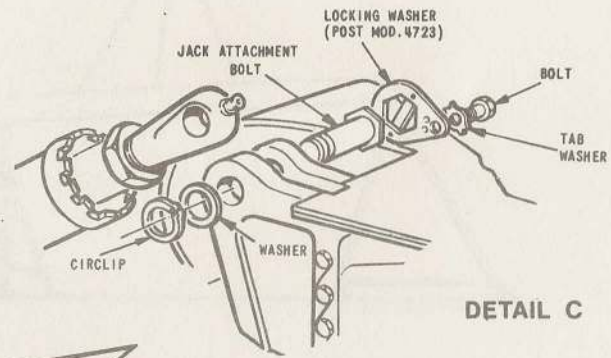

STARBOARD MAIN PLANE LOWER SURFACE

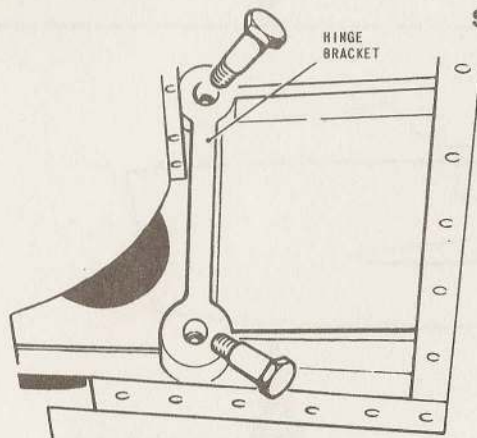

DETAIL A  
CENTRE HINGE BRACKET

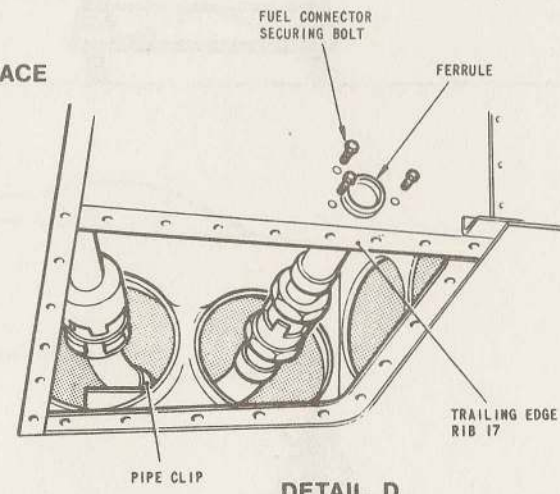

DETAIL D  
OUTBOARD FUEL CONNECTOR

FIG.13. FLAPS - REMOVAL AND ASSEMBLY

◀MOD.4723 EMBODIED▶

RESTRICTED

assembled to the main plane. The tank is attached to the main plane by bolting the four brackets on the shear wall to corresponding brackets on spar 1, and by countersunk bolts which pass through the tank skins into nut plates attached to the spar booms. When assembled to the aircraft, the open-sided box formed at the inboard end covers items of electrical equipment secured to the fuselage. Forward of the box a small fairing is added to complete the aerodynamic shape of the assembly. A number of detachable panels in the tank top skin and the shear wall provide access to the fuel system internal components. The box incorporates detachable panels which give access to electrical equipment and the inboard fuel connections. Rubber sealing strips close the gap between the fuselage and the tank assembly.

### SERVICING

#### WARNING

The relevant safety precautions detailed on the LETHAL WARNING marker card must always be observed before entering the cockpit or performing any operations upon the aircraft.

#### General information

8. Apart from normal inspection for damage and the security of components no servicing of the main-plane is necessary. Instructions for servicing controls and equipment housed in the main-plane assemblies are contained in their associated chapters.

### REMOVAL AND ASSEMBLY

#### Tools and equipment

9. For tools and equipment used in removal and assembly operations, refer to Table 1.

#### Slinging (fig. 3)

10. A sling is provided for lifting the main planes, either as a unit or separately. In the former case the complete sling assembly, with the exception of the steady struts, is used. When lifting the main planes as single units only the appropriately-handed sub-assembly is required. Should residual fuel in the tank cause a main plane to be unbalanced, this can be corrected by attaching approximately 40 lb of ballast in the region forward of the aileron.

11. To lift a single main plane, the sling is attached at three points identified by stencilling on the upper wing surface; two of these points are threaded holes (normally closed by large slotted-head bolts) in brackets on spar 1, near ribs 8 and 12, to which the sling attachment lugs are secured. The remaining attachment is made to a slinging rod (fig. 3, detail A) which is inserted through a hole in the main plane after the removal of a closing plug and a special-to-type pin from the top and bottom wing skins respectively (fig. 4).

12. To remove slinging point plugs (fig. 4)

(1) Remove, using a screwdriver, the two slotted-head bolts in the upper surface of the leading-edge fairing.

(2) After unlocking the closing plug in the upper surface of the main plane, directly above the special-to-type pin hole, remove it by turning the centre screw.

(3) Locate the special-to-type pin in the lower surface of the main plane directly below the closing plug hole, and inboard of the aft end of the main undercarriage pivot bracket.

(4) Using the screwdriver end of the pin extractor, turn the grub screw clockwise into the body of the pin until the ball catches unlock.

(5) Screw the bolt end of the extractor into the threaded hole left by the grub screw and remove the pin.

#### Main plane

##### Removal

#### 13.

(1) Jack and trestle the aircraft (Sect. 2, Chap. 4).

(2) Remove the flaps (para. 15).

(3) Remove the ailerons (para. 17).

(4) Remove the main undercarriage (Chap. 5).

(5) Remove the main and emergency batteries.

(6) Raise the aircraft on its jacks and trestles and fit the front fuselage trolley.

(7) Remove the engines and jet pipes (Sect. 4, Chap. 1).

## RESTRICTED

- (8) Remove the front fuselage (*Chap.1*).
- (9) Support the main-plane assembly at the front centre rib on the tripod (*fig.12*).
- (10) Remove the leading-edge fuel tanks (*para.19*).
- (11) Disconnect the systems at the port and starboard leading edges.
- (12) Disconnect the systems at the port and starboard trailing edges (*fig.7 and 8*).
- (13) Disconnect the systems and remove the components in No.1 engine bay, port and starboard, (*fig.8, 9, 10 and 11 respectively*).
- (14) Disconnect and remove the main-plane attachment bolts in the reverse order to the assembly instructions laid down in A.P.101B-1000-6, Part 1, *Chap.3*.

### Note...

*It is advantageous at this point to set out a centre line and guide lines from the aircraft on the hangar floor - the guide lines conforming to the trolley track. The trolley can then be accurately aligned for run-out and run-in and excessive manoeuvring when removing or assembling the main planes thereby obviated.*

### Assembly

14. The main plane is to be supported by 10-ton jacks at the normal jacking points and a tripod fixed at the front of the centre line joint. The rear fuse-

lage is carried by a trolley lined up with the markings on the hangar floor (*para.13*).

(1) Using a main plane incidence gauge, a leveling gauge, and a clinometer, adjust the main plane for longitudinal and lateral level.

(2) Position the rear fuselage with the main-plane slot coincident with the rear end of the main plane.

(3) Check the longitudinal and lateral levels along and across the fuselage main-plane slots, using an incidence gauge and clinometer. Make any adjustments by operating the screwjacks integral with the trolley, ensuring that these do not adversely affect the line-up between the fuselage and main plane. With the fuselage slot longitudinally level the fuselage incidence is 2 deg negative.

(4) Slowly run in the rear fuselage to the main plane until the latter is fully accepted. During the run in, careful observation must be kept on both the fuselage and the main plane to ensure that no damage occurs as a result of fouling of the two structures.

(5) Should either the rear fuselage or the main plane be a new component requiring drilling or reaming operations, refer to A.P.101B-1000-6 for the assembly procedure. Otherwise, refitting is the reverse procedure of that described in *para.13*.

(6) Carry out functioning tests (*Chap.1 - Front fuselage, assembly*).

### Flaps (*fig.13*)

#### Removal

15. To remove a flap:-

(1) Defuel the flap tank and the associated main-plane tank (*Sect.2, Chap.2*).

(2) Connect a 28-volt ground d.c. electrical supply to the aircraft (*Sect.2, Chap.2*).

(3) Remove the hydraulic system hand-pump handle from its stowage in the port wheel well and fit it to the pump (access panel 79P).

(4) Remove access panels 121, 122, 125, 126, 127, 129, and 130 in the lower flap shroud.

(5) Select flaps DOWN and apply hydraulic pressure with the hand pump to fully lower the flaps.

(6) Disconnect the hydraulic jack end fittings from the flap. Select flaps UP and withdraw the jack rams from the hinge brackets by applying hydraulic pressure.

(7) Disconnect the flap position-transmitter link at the flap (defuelling panel).

(8) Disconnect the cables to the float switch at the flap inboard end, from the terminal block on main-plane trailing-edge rib 3 (access panel 121).

(9) Disconnect the two coaxial cables to the tank gauge units from the connectors on the flap leading-edge (access panels 126 and 129).

(10) Withdraw the sleeves of the fuel/air telescopic adapters from the hinge pins (*detail B*).

(11) Remove the ferrule from the outboard fuel adapter by releasing the pipe connector at the flow-sensing valve, slackening the pipe clip at trailing-edge rib 17, removing three 4 B.A. bolts from the ferrule, and sliding the ferrule from the rib (*detail D*).

(12) Position a flap sling suspended from a 30-cwt pulley block over the main plane and secure the attachment straps to the jack-attachment holes by the flap jack bolts.

(13) Remove the hinge bracket-attachment bolts (noting the positions of any shim washers which are to be retained for subsequent refitting if the same flap is being assembled).

(14) Support the flap at the trailing edge, manoeuvre it aft to clear the flap shrouds (about 2 in. of movement), and lower it vertically by the lifting tackle.

(15) Blank all open pipes and electrical plugs.

#### Assembly

16. To assemble a flap to the main plane: -

(1) Using the flap sling and pulley block (*para. 15*), raise the flap to a

suitable position for assembly to the main plane.

(2) Apply a film of pigmented varnish Ref.No. 33C/1264 to the shanks of the hinge bracket-attachment bolts.

(3) Offer up the flap to the main plane and secure the hinge brackets, ensuring reasonable ease of entry of bolts and fitting any shim washers in their original positions. Remove the sling.

#### Note...

*If a replacement flap is being fitted, tighten the bolts in the outboard hinge bracket first. Afterwards check for clearance between the remaining hinge brackets and the main-plane attachment points at the top bolt position for the centre hinge bracket, and the forward bolts positions for the inboard bracket. If there is clearance, it must be taken up with special-to-type shim washers, which have 0.002 in. laminations. The tolerance allowed in the fit is 0.002 in. which must not be exceeded.*

(4) Fit the outboard fuel/air adapter ferrule and the fuel pipe, leaving the ferrule attachment bolts loose. Wire-lock the fuel connector.

(5) Engage the fuel/air adapter sleeves with the hinge pins. Tighten the three bolts in the flange of the outboard adapter. Wire-lock the adapter pins.

(6) Connect the float switch and tank gauge unit cables, ensuring that there

is sufficient slack in the cables to permit full flap movement.

(7) Connect the position transmitter link.

(8) Manually raise the flap and check that the trailing edge is in alignment with both the main-plane trailing edge and the fuselage fillet. Slight malalignment can be taken up by adjustment of the fillet.

(9) Lower the flap sufficiently to avoid any possibility of fouling when the jack rams are extended.

(10) Using the hand pump, fully extend the jack rams. Manually raise the flap, and if necessary adjust either ram end fitting until a simultaneous engagement of the inboard and outboard anchorages and the associated ram can be made and the connecting pins inserted. (*Refer to detail C, fig. 14*).

(11) Raise the flap, using the hand pump, and check, by reference to the jack up-lock indicators, that the up-locks on both jacks are engaged. Repeat the trailing edge alignment check. Any malalignment should now be equal at the main-plane and fuselage check points and therefore rectifiable by equal adjustment of both ram end fittings. Care must be taken to ensure equal movement of the ram end fittings during this adjustment.

(12) Refuel the aircraft and check for leakage from the flap tank fuel connector.

(13) Using the hand pump, operate the flaps and check for fuel leakage from the hinge adapter.

(14) Continue flap operation, check for fouling and listen for straining of the flap structure.

(15) Connect a hydraulic servicing trolley to No.1 services hydraulic system (access panel 45P) and repeat operations (11) and (12).

(16) Remove and stow the hand-pump handle.

(17) Fit and secure the access panels.

**Ailerons (fig.14)**

*Removal*

17. To remove an aileron:-

(1) Connect a hydraulic ground servicing trolley to either of the controls systems (Sect.2, Chap.4).

(2) With an assistant in the cockpit operating the control column handle toward the position in which the aileron will be moved down, apply sufficient pressure with the trolley hand pump to operate the ailerons but not to pressurize the accumulator.

(3) Remove access panels 102A and B.

(4) Remove the locking wire from each p.f.c.u. tail-piece retaining nut.

(5) Unscrew the retaining nuts, using a torque adapter assembly for the initial loosening of the nuts, and, if required, a 'C' spanner to complete the removal.

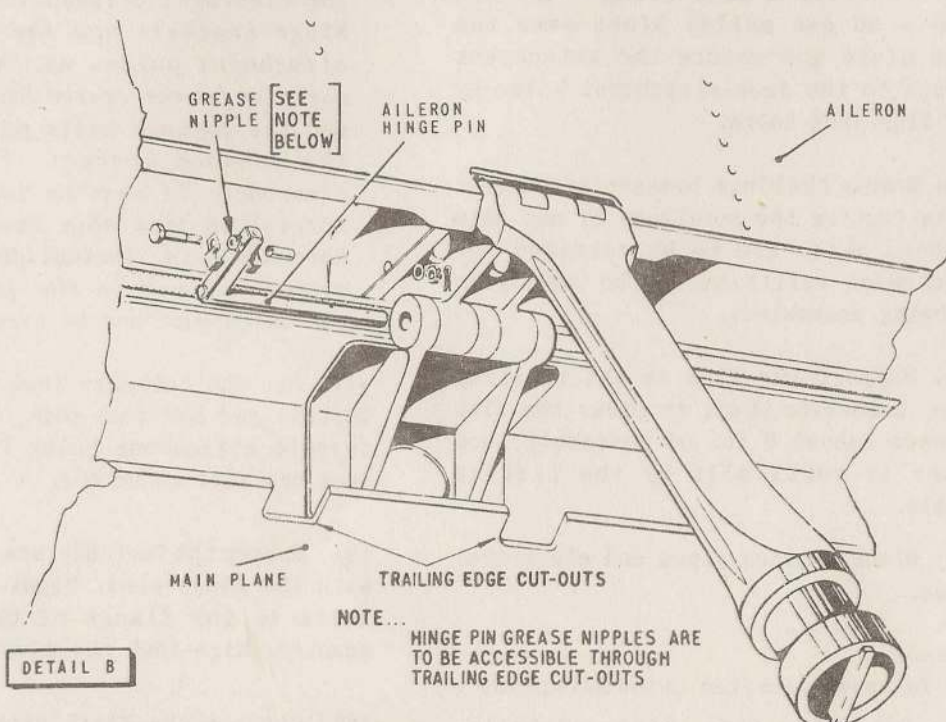
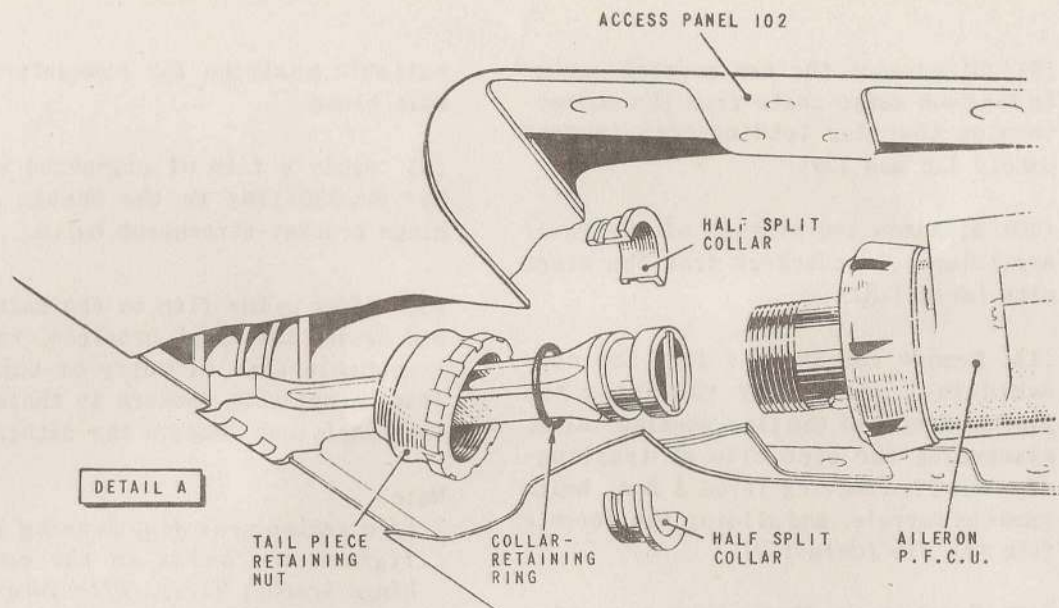

Fig.14. Ailerons - removal and assembly

I-8306-1

NOTE:-  
HYDRAULIC PIPES, FLYING CONTROL RODS  
AND CABLE LOOMS ARE OMITTED  
FROM SPAR 1 FOR CLARITY

★ REMOVE THESE BOLTS LAST AND  
INSERT THEM FIRST

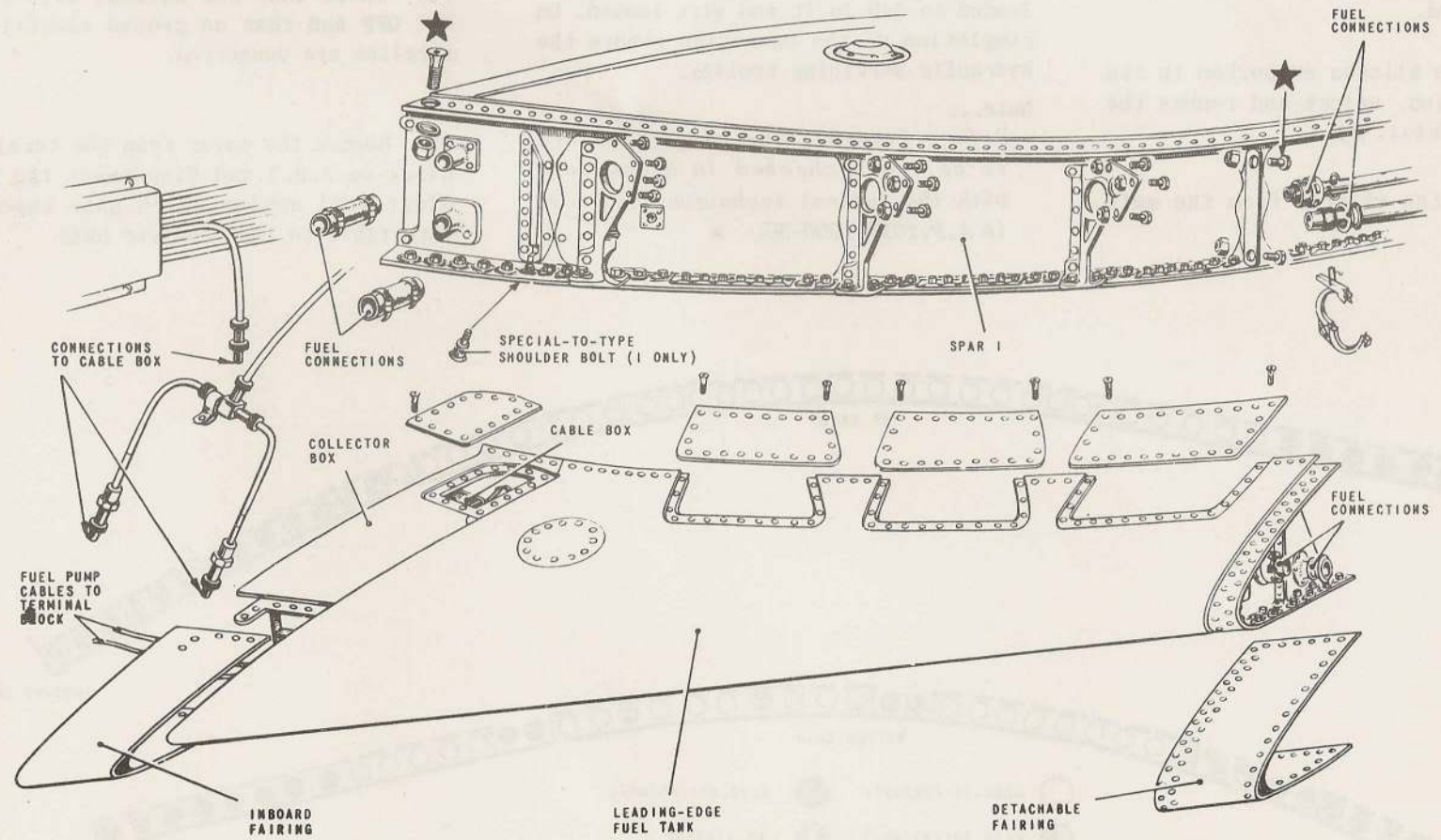

FIG.15. LEADING-EDGE FUEL TANKS-REMOVAL AND ASSEMBLY

3-8307-1

(6) Slide the nuts aft and remove the split collars. Lift the aileron and remove the nuts (detail A).

**Note...**

Identify the nuts and collars to ensure that they are subsequently assembled to the p.f.c.u. from which they were removed.

(7) With the aileron supported in its raised position, unlock and remove the hinge pins (detail B).

(8) Remove the aileron from the main plane.

**Assembly**

18. Assembly of the aileron to the main plane is the reverse of the removal sequence (para.17). When fitting the hinge pins ensure that the grease nipples are accessible through the cut-outs in the main plane trailing-edge. The p.f.c.u. retaining nuts are to be torque loaded to 210 lb ft and wire-locked. On completion of the operation remove the hydraulic servicing trolley.

**Note...**

Before fitment, the hinge pins are to be crack checked in accordance with the current technique laid down in A.P.101B-1000-5G. ▶

**Leading-edge fuel tanks (fig.15)**

**Removal**

19. To remove the tank:-

(1) Defuel the associated main tank (Sect.2, Chap.2).

(2) Check that the BATTERY switch is set OFF and that no ground electrical supplies are connected.

(3) Remove the cover from the terminal block on J.B.7 and disconnect the two electrical cables which pass through tank rib 1 to the transfer pump.

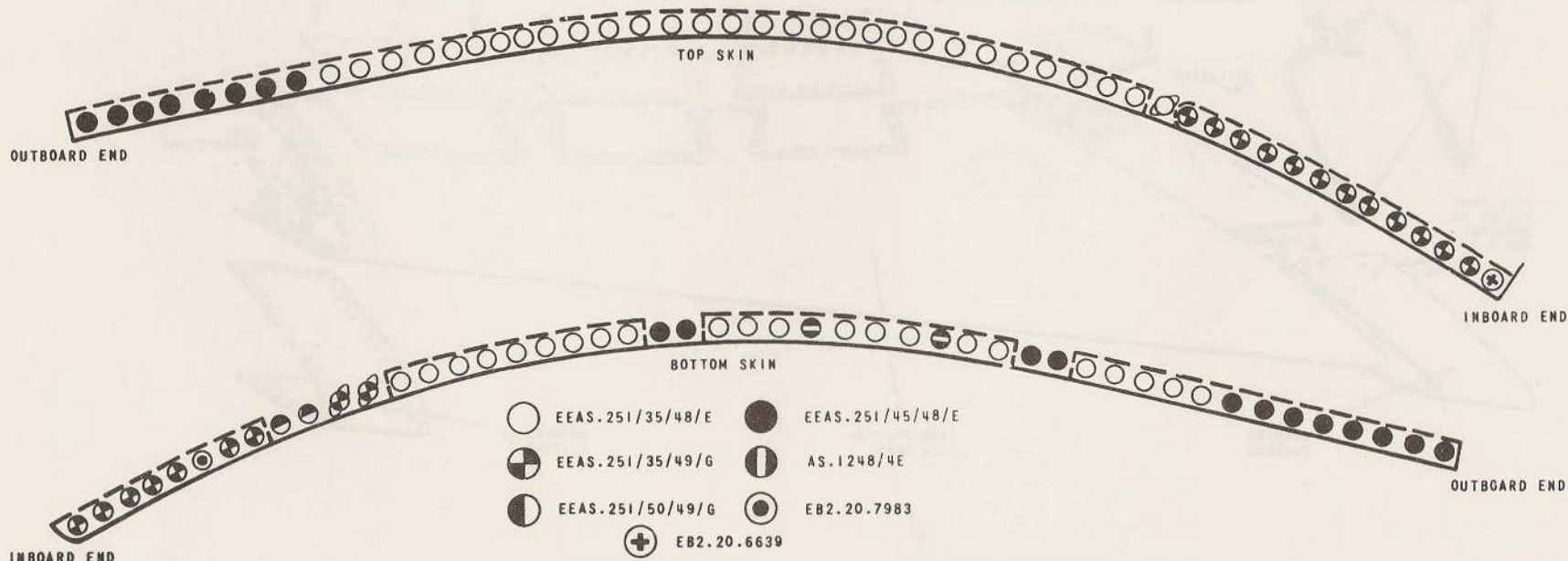

3-8308-1

Fig.16. Leading-edge fuel tanks - Key to bolt attachments

(4) Disconnect the two coaxial cables from the cable box, and a similar cable from tank rib 1 (access is through the inboard detachable panel).

(5) Remove the outboard fairing and disconnect the four fuel pipes, two inboard and two outboard.

(6) Remove the countersunk bolts from the spar 1 lower boom.

(7) Remove the countersunk bolts from the spar 1 upper boom with the exception of the large bolt at the inboard end.

(8) Examine the main attachment brackets for the presence of shims between the mating faces. If any are fitted note their positions to ensure correct assembly when refitting the tank (*para. 20*).

(9) Remove the four bolts at the inboard attachment bracket, and seven

bolts, nuts and washers from the remaining brackets; do not remove the top bolt in the outboard bracket at this stage.

(10) Support the tank manually and remove the remaining countersunk bolt and the bracket bolt.

(11) Remove the tank and place it in a storage stand.

#### Assembly

**20.** Assembly of the leading-edge tank to the main plane is a reversal of the removal procedure (*para. 19*). Commence with the two bolts removed in operation (10) and tighten the outboard bolt fully before inserting the inboard bolt. Take care to insert any shims in their correct positions. Do not refit the access panels before making the tests (*para. 21*). The correct positioning of the spar boom attachment bolts is shown in fig. 16.

#### Testing

**21.** Make the following tests after assembly:-

(1) Refuel the aircraft and check that there is no leakage from the inboard pipe connections and from the light-weight pipe connector on the larger outboard pipe.

(2) Check that the associated fuel gauge registers the correct quantity of fuel.

(3) With d.c. power supplies (only) connected to the aircraft, and the H.P. cocks CLOSED, switch on the pumps in the associated main plane and check for leakage from the smaller of the two outboard pipes. Switch off the pumps.

(4) Disconnect the power supplies and fit the access panels.

## RESTRICTED

TABLE 1

## Tools and equipment

Ref. No.	Part No.	Description	Application/remarks
	EB1.88.1001	Tripod, wing support	Main-plane removal/assembly
	AP1J11/12341	Bracing, lower engine hatch aperture	
	AP6J11/017	Rig, assembly, frame 25B	
26DK/95004	EB2.88.407	Pad, wing jacking (2 off)	
26DK/95028	EB2.88.693	Plate, steady, frame 25B	
26DK/95029	EB2.88.3279	Gauge, incidence wing	
26DK/95087	EB1.88.99	Pin, rigging (set of 3)	
26DK/95088	EB1.88.951	Extractor, special pin	
26DK/95099	EB2.88.2185	Gauge, leveling, longitudinal	
26DK/95235	EB2.88.4035	Spanner, special	
26DK/95250	EB2.88.4147	Bullet, lead in	Wing-to-fuselage rear attachment bolts
26DK/95818	EB3.88.197	Bullet, lead in	Wing-to-fuselage forward attachment bolts
26DK/95347	EB2.88.5823	Sling, port and starboard basic wing combined	Main-plane removal/assembly
26DK/95813	EF3.88.1009	Trolley, rear fuselage	
	EB2.88.5051	Lever, assembly (use with 26DK/95813)	
26DK/95839	EF3.88.235	Trolley, front fuselage	
4Q/1045836		Jack, pillar, hydraulic, 8-ton (2 off)	
4Q/1045835		Jack, hydraulic, 10-ton (2 off)	
4Q/2232		Jack, hydraulic, 5-ton	
4Q/2294		Trestle, Mk.1 (3 off)	
4Q/2661		Adapter head, Mk.105 (2 off)	
		standard clinometer (2 off)	
26DK/95266	EB2.88.4263	Sling, flap fuel tanks	Flap removal/assembly
26DK/95290	EB2.88.4689	Stand, storage, flap fuel tanks	
4L/2014		Block, pulley, geared 30 cwt	
4F/3603		Trolley, hydraulic, ground servicing Mk.3	Aileron removal/assembly
26KH/2779	CHA 107621	Assembly, torque adapter	
26DK/95114	EB2.88.2009	C-spanner	Leading-edge tank removal/assembly
26DK/95288	EB2.88.4685	Stand, storage	
26DK/95350	EB2.88.5633	Stand, storage	

RESTRICTED

This file was downloaded  
from the RTFM Library.  
Link: [www.scottbouch.com/rtfm](http://www.scottbouch.com/rtfm)

Please see site for usage terms,  
and more aircraft documents.

