

trol column to the tail-plane p.f.c.u. The lower member contacts adjustable stops which limit fore-and-aft movement.

Upper member

3. The upper member pivots laterally about its attachment to the lower member and rotates a combined torque tube and centring unit which terminates in a lever. A control rod connected to the

lever transmits movement to the control run which operates the aileron p.f.c.u.

Control handle (fig.2)

4. A control handle is fitted to the upper member of the control column. At the base of the handle is the wheel-brake lever with its associated parking catch on the port side. A press-to-transmit switch is housed in a boss half-way up the grip on the port side.

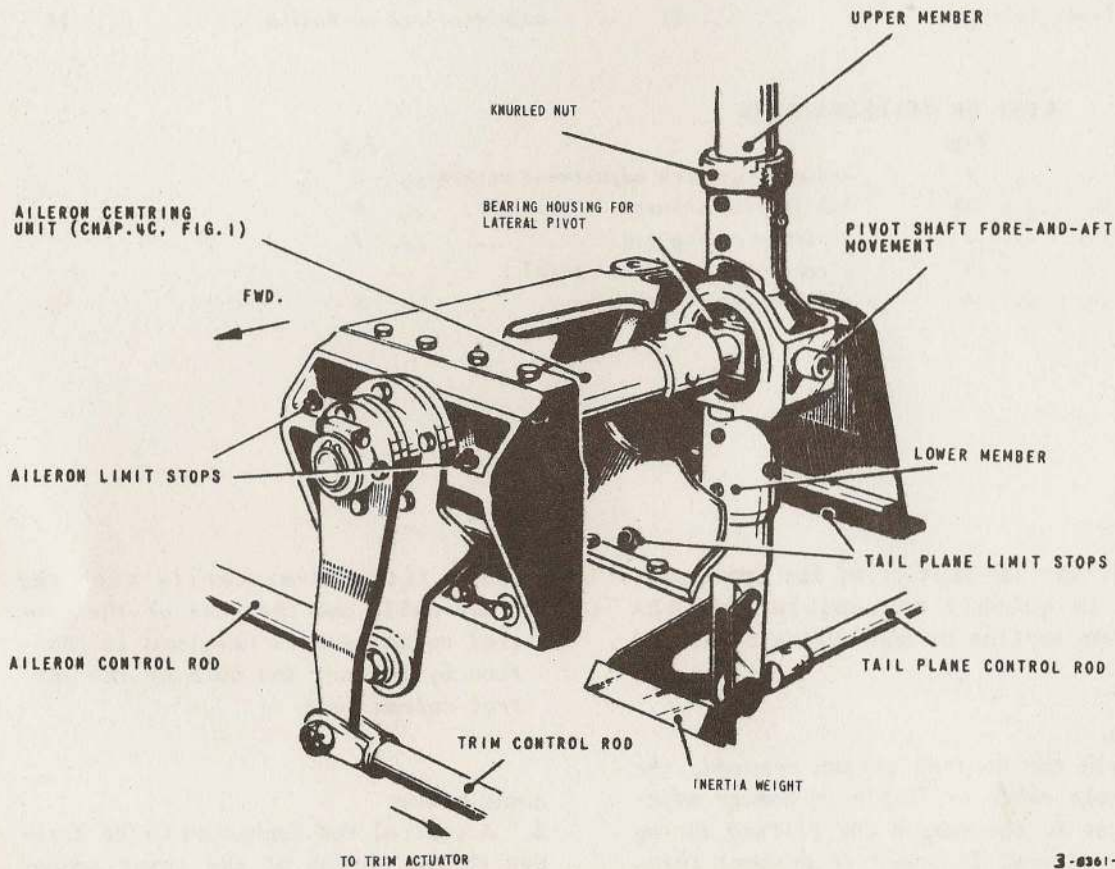

Fig. 1. Control column

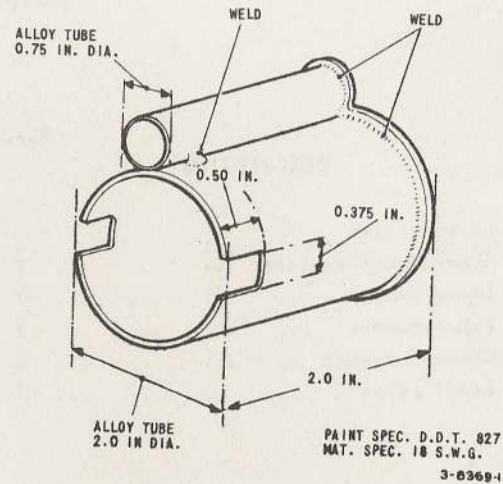

Fig. 1A. Brake cable guard

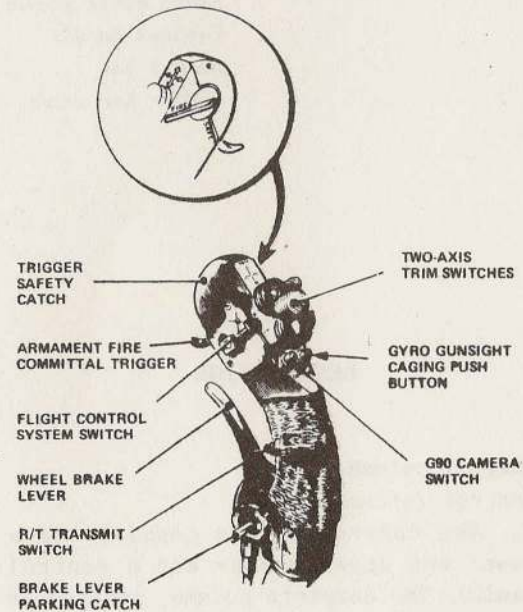

Fig. 2. Control handle

The top of the handle accommodates switches for the camera, gyro gunsight caging push button, flight control system and coupled 4-way trim switches. At the front of the handle is the armament fire-committal trigger with its safety catch on the starboard side. Datum marks for rigging purposes are inscribed on the port side of the handle.

Limit stops (fig.1)

5. Fore-and-aft movement (for tail-plane control (Chap.4E)), of the control column, is limited by adjustable stops screwed into the mounting structure. The aft stop, i.e. the one which limits

the forward movement of the column is accessible from outside the column mounting structure; the forward stop can be adjusted through a cut-out in the starboard side of the mounting structure. Lateral movement (aileron control) of the control column is limited by adjustable stops placed at the forward end of the mounting structure; these are accessible externally.

Rudder bar

General information (fig.3)

6. The rudder bar assembly is mounted on a vertical pivot shaft, supported in a pedestal bolted to the cockpit floor.

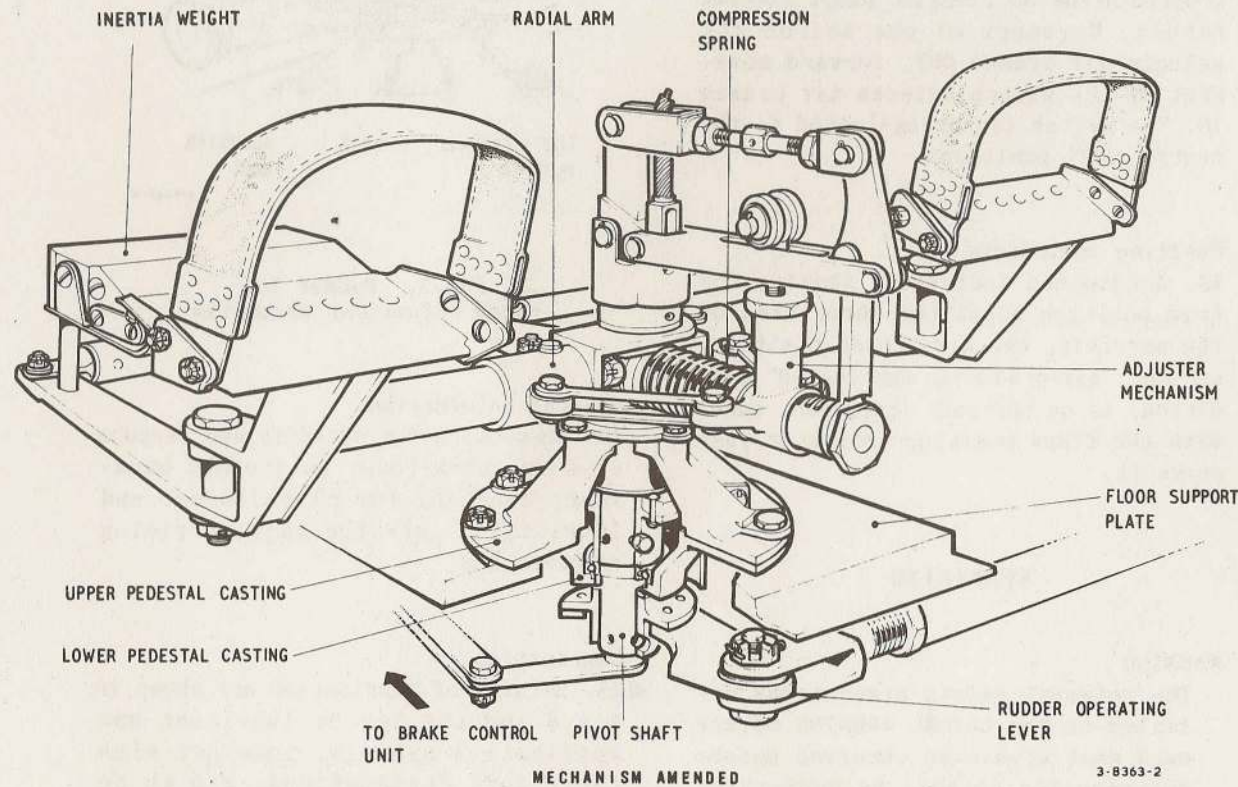

Fig.3. Rudder bar

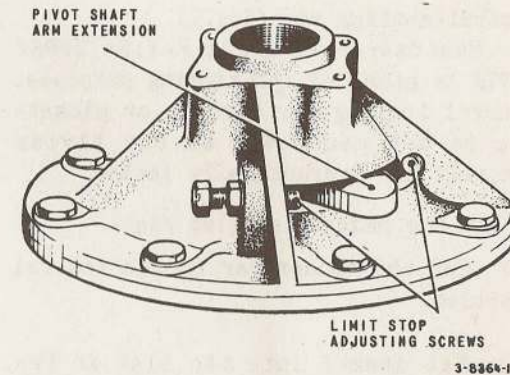

Fig.4. Rudder bar stops

Levers below the floor transmit movement to the rudder control rods. The pedal arms have fork-ends which fit on to the pivot shaft, and an adjuster mechanism locks the two arms together so that they pivot about the pivot shaft as a single unit.

Limit stops (fig.4)

7. Movement of the rudder bar is limited by an arm on the pivot shaft which protrudes through a slot in the pedestal and contacts adjustable stops.

Leg-reach adjustment (fig.5)

8. The rudder pedals are adjusted for leg-reach by pulling out a handle fitted above the centre instrument panel. This action raises the toothed plunger and frees it from the rack, allowing the compression spring to push the plunger housing assembly aft. The links joining the pedal arms to the plunger housing move the pedals in the same direction, the pedal arms pivoting about the pivot shaft. With the toothed plunger released, the pedals can be moved to the desired position by the feet, and then locked by releasing the handle to allow the spring-loaded plunger to re-engage the rack.

RESTRICTED

Neutral-setting rig (fig.7)

9. Neutral-setting rig Ref.No.26DK/95778 is provided for rigging purposes. Control locking for parking or picketing is not necessary as the flying controls are hydraulically locked.

To fit the neutral-setting rig:-

- (1) Set the rudder bar to the neutral position.
- (2) Fit item 1 into the slot in the rudder bar pedestal, ensuring that the arm on the pivot shaft engages the cut-away in item 1.
- (3) Secure the split rings around the limit-stop adjusting screws.
- (4) Tighten the knurled nuts until item 1 is held firmly in position (avoid over-tightening).
- (5) Position the platform of item 2 at the base of the control column immediately below the knurled nut.
- (6) Slide the clamping block into position and secure it to the platform with the two retaining bolts.

Trim switches

10. Rudder trim is controlled by two 2-way switches, on the port console, which are normally operated together. Aileron and tail-plane trim are effected by dual 4-way switches on the control column handle (fig.2). The switches are moved fore-and-aft for tail-plane trim and laterally for aileron trim (Sect.6, Chap.3).

Flap selector

11. The flap selector, located on the port instrument panel, has two marked positions, UP and DOWN. The selector controls the solenoids of an electro-hydraulic selector valve which directs the flow of hydraulic fluid to the flap jacks (Chap.6). If the flaps are left down a pitot pressure switch, operative at 250 knots, returns them to up whilst this speed is exceeded.

Air-brake selector

12. The air-brake selector switch is mounted on the No.2 engine power control handle. Movement of the switch aft selects air brakes OUT; forward movement of the switch selects air brakes IN. The switch is spring-loaded to the centre 'off' position.

Position indicators

13. A combined indicator, showing the trim position about the three axes of the aircraft, the air-brakes position, and the 'air-brakes in and locked' condition, is on the port instrument panel with the flaps position indicator just above it.

SERVICING

WARNING

The relevant safety precautions detailed on the LETHAL WARNING marker card must always be observed before entering the cockpit or performing any operations upon the aircraft.

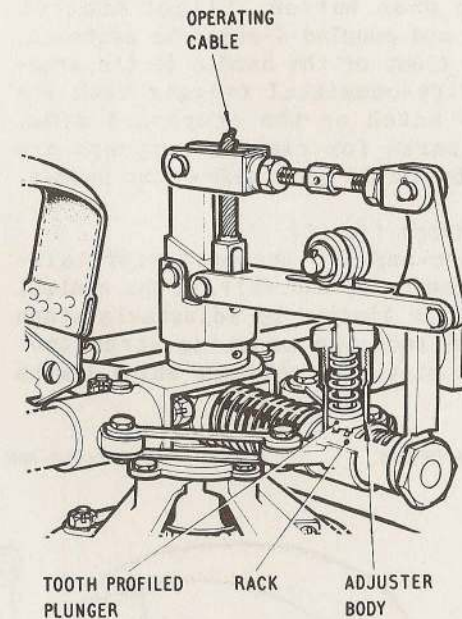

Fig.5. Rudder leg-reach adjustment mechanism

General information

14. Inspection for security and freedom of movement without noticeable backlash, checking for cleanliness, and lubrication, are the main servicing requirements.

Lubrication

15. Details of lubrication are shown in fig.6 and the key to lubricant and application symbols, together with their full designations, are to be found in Leading Particulars. ▶

RESTRICTED

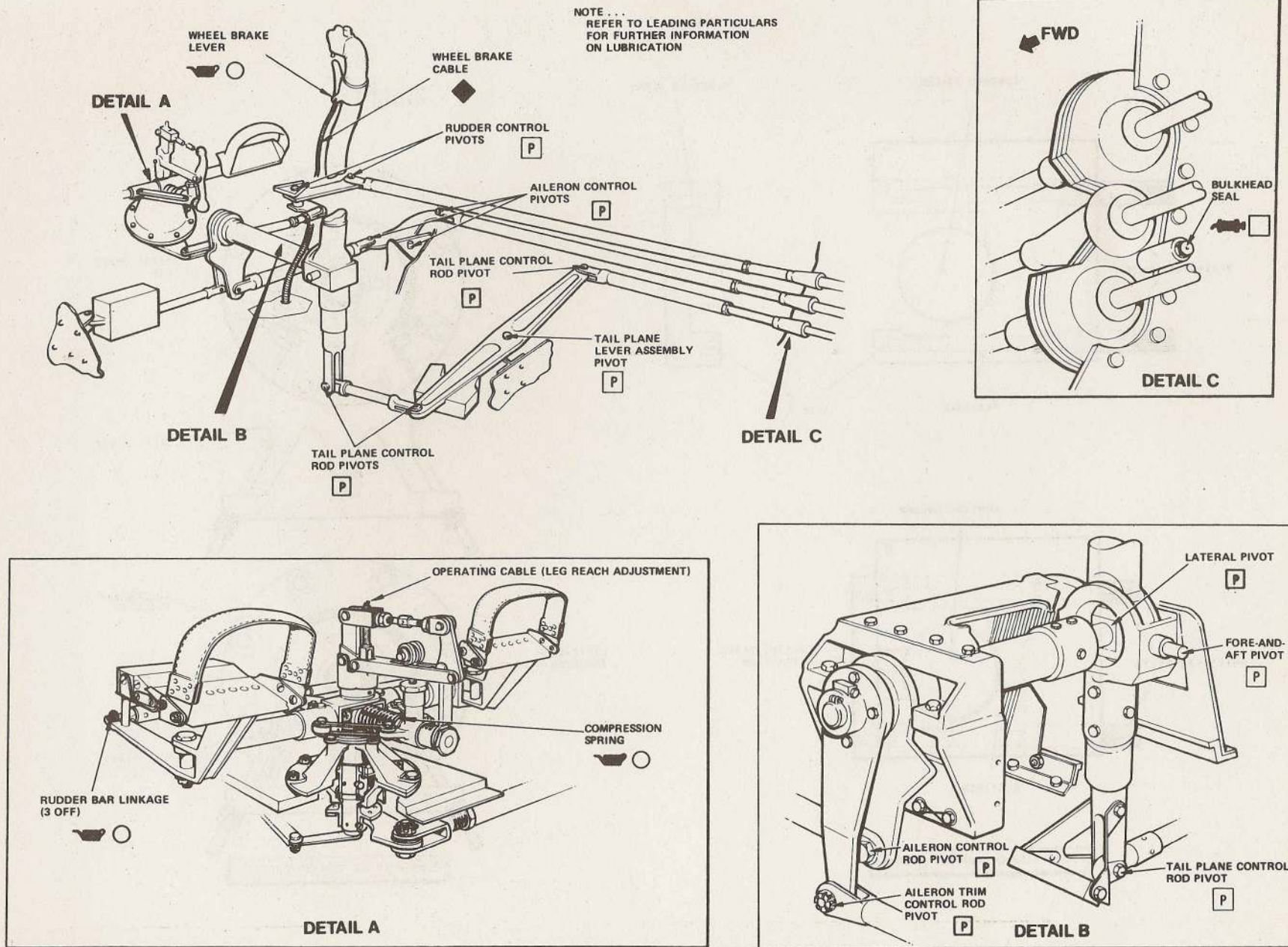

FIG. 6. LUBRICATING POINTS

◀REDRAWN▶

RESTRICTED

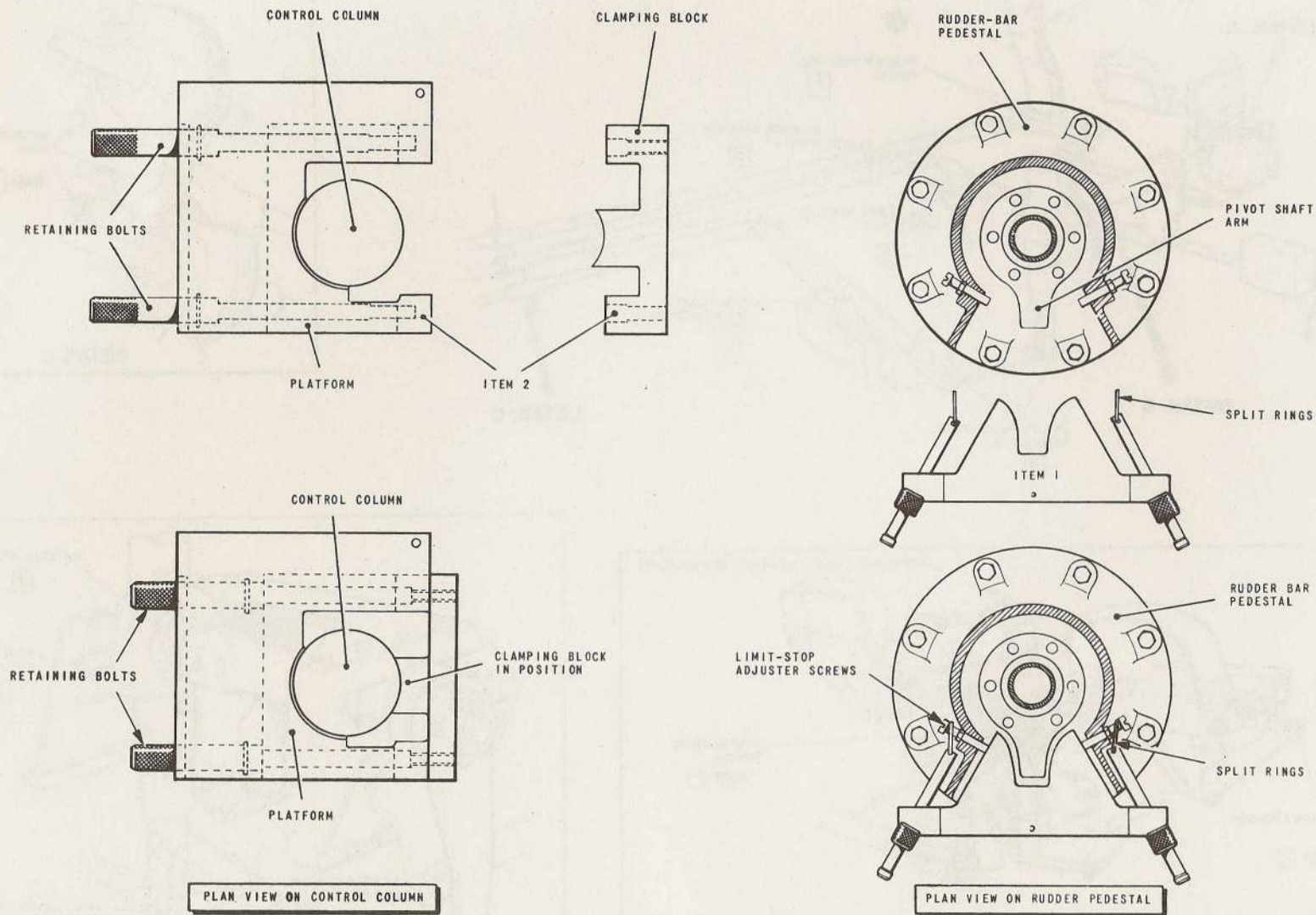

FIG.7. NEUTRAL-SETTING RIG

3-8366-1

RESTRICTED

◀ **Resetting the rudder pedal
adjuster-lock mechanism (fig.8)**

16. To reset the mechanism:-

(1) Gain access to the lock-release handle assembly, forward of the centre instrument panel and to the rudder bar assembly.

(2) Check that the lifting link over the rack is not disturbed, that the cable conduit is correctly seated at both ends and that the cable adjuster is within the limits quoted in fig.8. If necessary, slacken the locknut and turn the adjuster to achieve these conditions.

(3) Pull the handle fully out and check that the plunger of the lifting rod

assembly is free from engagement with the rack. Release the handle. Check that the ball races on the lifting rod are just free to rotate at all positions throughout the fore-and-aft travel of the lifting rod assembly. If necessary, remove the locking wire, slacken the locknuts and adjust the turnbuckle to achieve these conditions. If the settings obtained in (2) are disturbed, readjustment of the cable assembly, within the limits quoted, is permissible.

Note...

The friction in this mechanism must not be sufficient to deter the spring from returning the linkage to the normal position on release of the handle.

(4) Pull the handle fully out and retain it in this position. Ensure that the rack compression spring returns the pedals to the aft position. Attach a spring balance at the centre line of one of the pedals and check that an applied forward load of 3 lb does not move the pedal. Remove the spring balance and release the handle.

(5) Check that with one pedal locked, any movement at the centre line of the opposite pedal does not exceed 0.080 in.

(6) On completion of satisfactory adjustment, tighten the locknut on the cable adjuster and the locknuts on the turnbuckle. Lock the turnbuckle with 22 s.w.g. locking wire D.T.D. 189. ▶

RESTRICTED

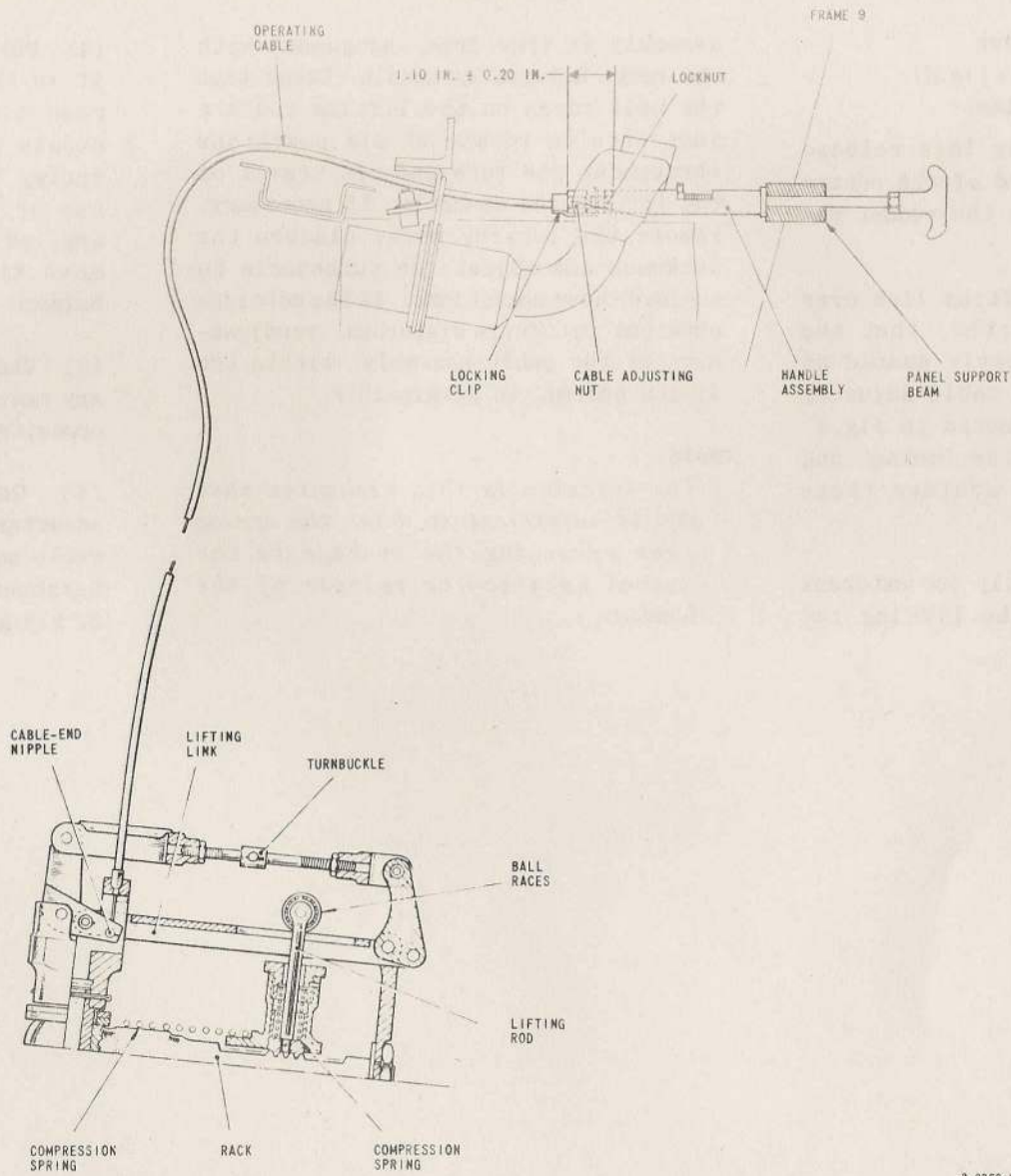

FIG. 8. ARRANGEMENT OF RUDDER PEDAL ADJUSTER-LOCK MECHANISM

RESTRICTED

This file was downloaded
from the RTFM Library.
Link: www.scottbouch.com/rtfm

Please see site for usage terms,
and more aircraft documents.

