

RESTRICTED

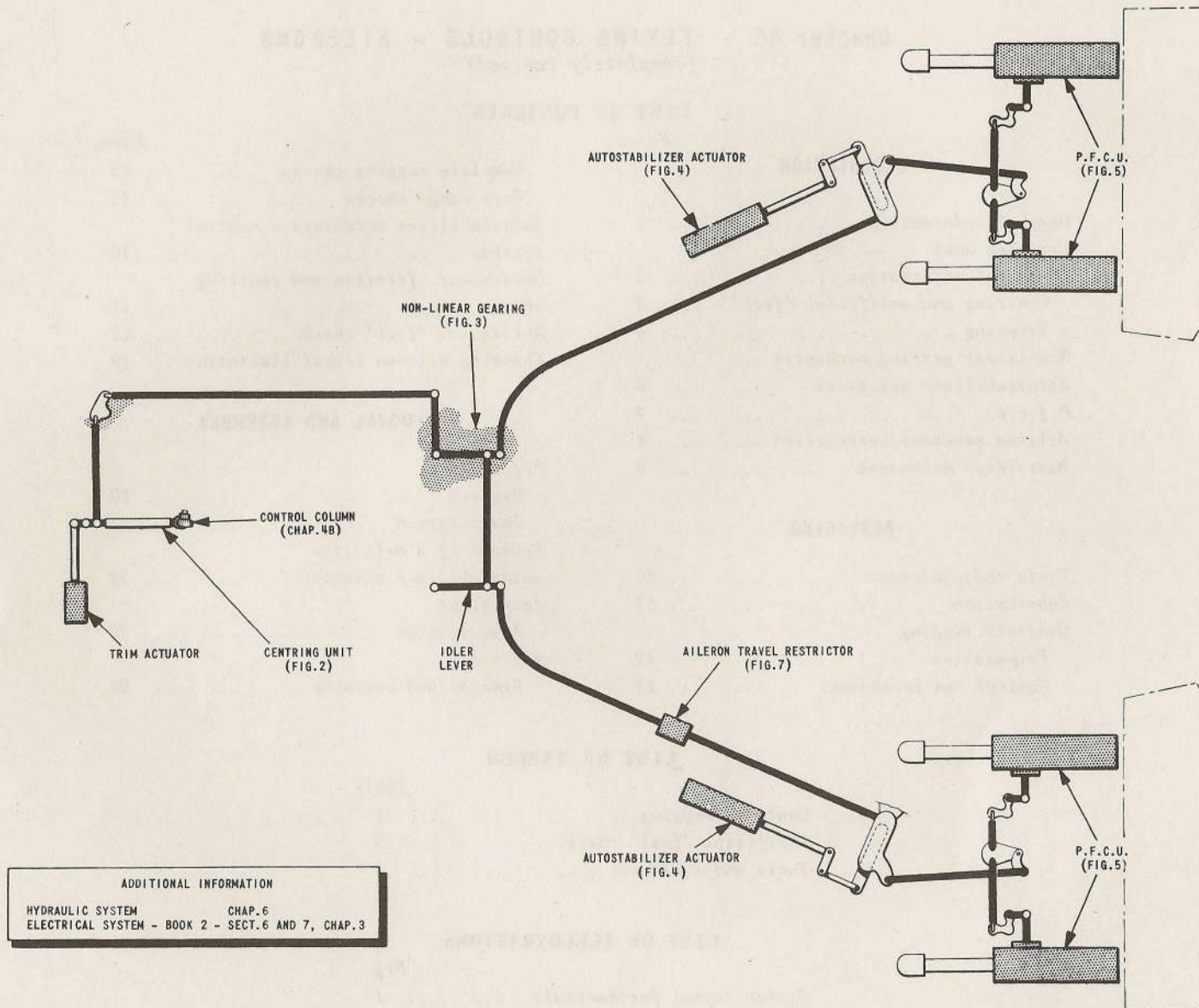

ADDITIONAL INFORMATION
HYDRAULIC SYSTEM CHAP. 6
ELECTRICAL SYSTEM - BOOK 2 - SECT. 6 AND 7, CHAP. 3

FIG. I. SYSTEM LAYOUT (MECHANICAL)

3-8389-1

RESTRICTED

DESCRIPTION

General information

1. Each aileron is power-operated by two hydraulically-powered flying control units (p.f.c.u.), supplied from separate hydraulic systems but operating simulta-

neously in response to lateral movement of the control column. Being power operated, there is no natural 'feel' in the control system and artificial 'feel' is provided by a centring unit. A non-linear gearing assembly modifies aileron response to control column movement.

Centring unit (fig.2)

General information

2. This unit converts lateral movement of the control handle into linear movement of the control run, provides artificial 'feel' and centring forces for lateral movement of the control column, and transmits trim effects to the control column and ailerons. The main components are a torque tube assembly connected to the control column and aileron lever, and a torsion shaft splined into the torque tube and trim actuator lever. The assembly is connected to the control column by a joint which allows universal movement of the upper member and handle of the control column.

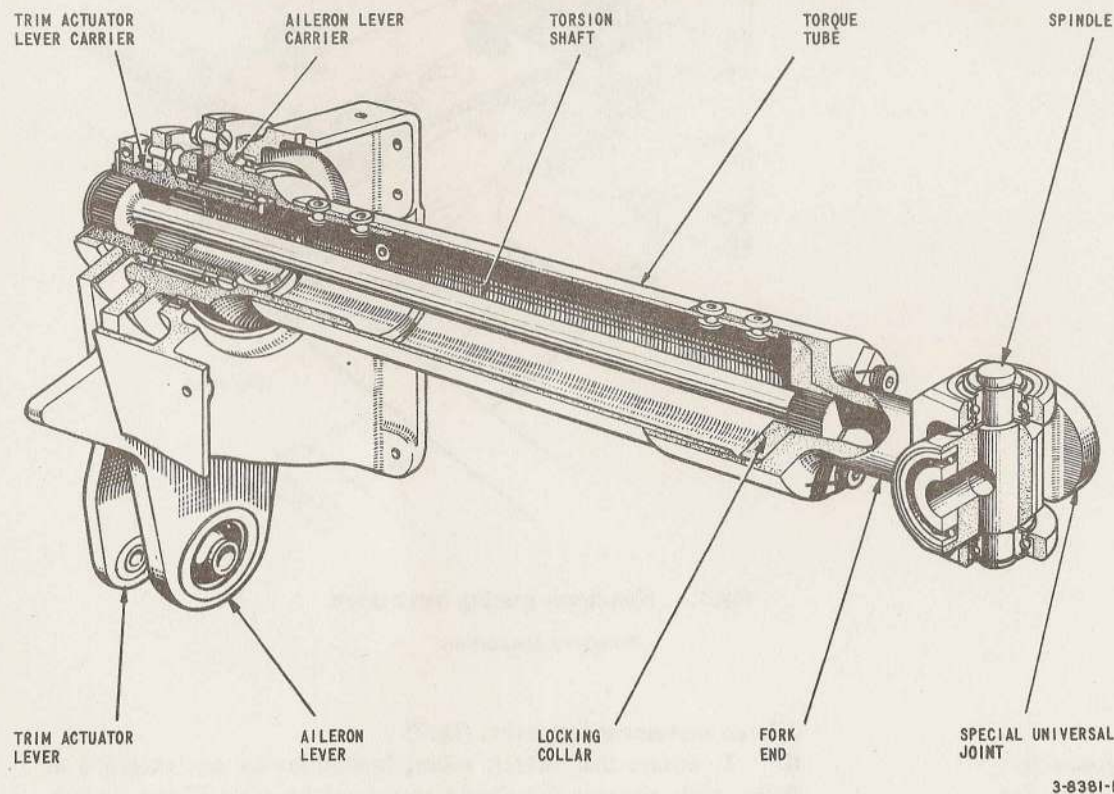

Fig. 2. Centring unit

Centring and artificial 'feel'

3. Centring and artificial feel result from torsion shaft resistance to lateral control column movement from the trimmed position, the torsion shaft being held at its forward end by the trim actuator ram. Feel force is directly proportional to control column movement. When the load on the control column is removed, the torsion shaft returns the control column and the ailerons to the trimmed position.

Trimming

4. Trimming is controlled by a four-position switch on the control handle. Lateral operation of the switch controls aileron trim by extending or retracting the trim actuator ram, with consequent rotation of the torsion shaft and torque tube. This moves the ailerons and the

control column to the selected trim position.

Non-linear gearing mechanism (fig.3)

5. The non-linear gearing corrects over-sensitivity of the aileron control at high speed by reducing aileron response to control column movement. The gearing is designed to effect this reduction principally over the small deflection range. A bracket on the aileron input lever enables the levers to be held in the neutral position by a rigging pin, when rigging the controls. The gearing assembly is mounted on the starboard main-plane front spar (access panel 26S).

Autostabilizer actuators (fig.4)

6. The autostabilizer actuators, powered by the services hydraulic system (Chap.6) are linked into both aileron control runs to operate the p.f.c.u. at the dictation of amplified electrical signals from the flight control system. The connection into the control run is designed to allow the autostabilizer to move the ailerons without moving the control column.

- ◀ 6A. Jury struts may be fitted in place of un-serviceable autostabilizer actuators when no replacement items are available, and otherwise serviceable aircraft are required to fulfil operational requirements (para.23). ▶

P.f.c.u

7. Each aileron is operated by two p.f.c.u., each power by independent hydraulic systems (Chap.6) but simultaneously controlled from the cockpit. Should the hydraulic supply to one control unit fail, the other unit will continue to operate the aileron but at a reduced power. The control units are installed with the body extension attached to the aileron and the fixed piston anchored to the main-plane structure.

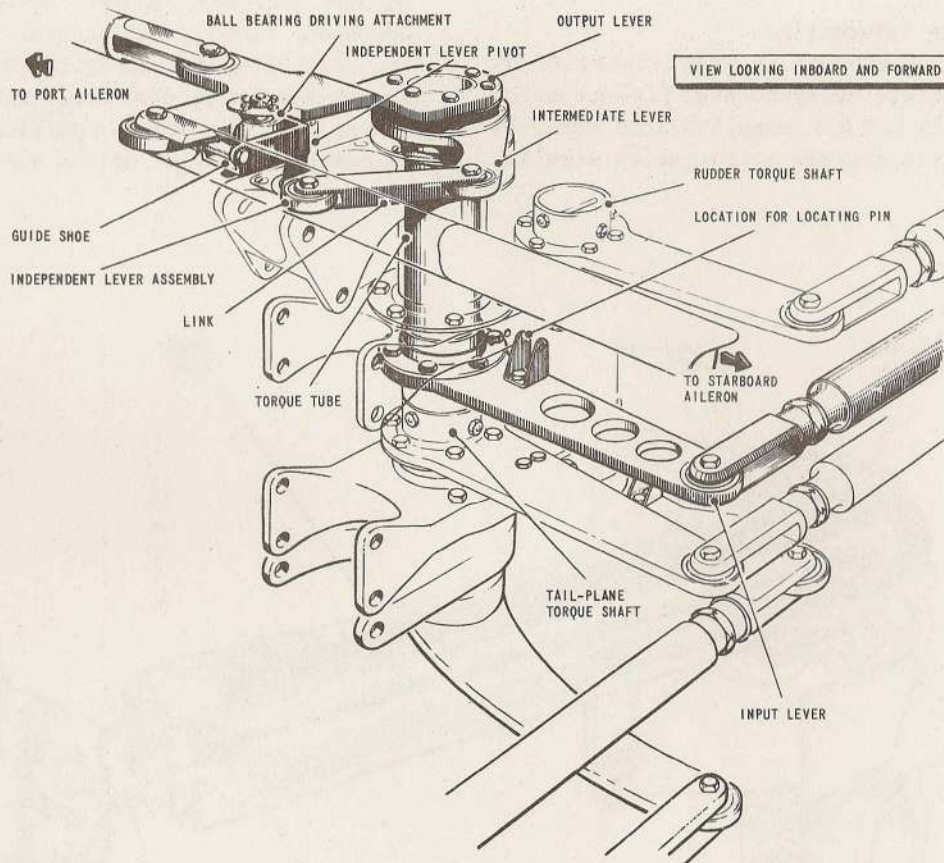

Fig.3. Non-linear gearing mechanism

Amended annotation

Aileron movement restriction (fig.7)

8. To ensure that aircraft rolling limitations are not exceeded in flight, while allowing full aileron movement for take-off and landing manoeuvres, a mechanical restrictor is fitted into the aileron control run in the port wing. When the alighting gear is down a spring-loaded connecting rod withdraws a lever from a spacing collar, allowing full movement of the aileron control run. When the alighting gear is up, the wheel-well door operates the door-lever on the connecting rod to overcome the

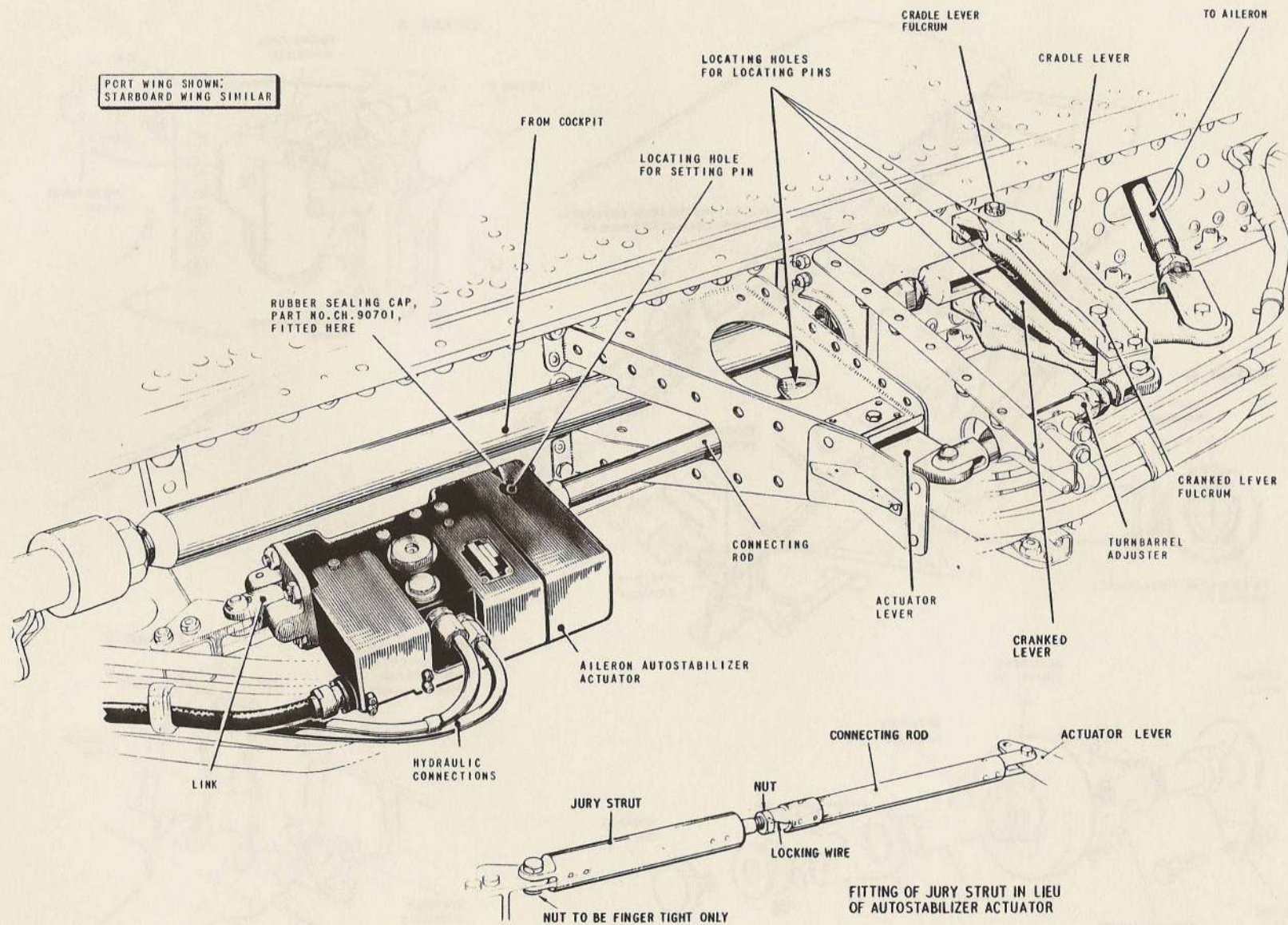

FIG.4. AUTOSTABILIZER - ACTUATOR INSTALLATION

3-8383-1

RESTRICTED

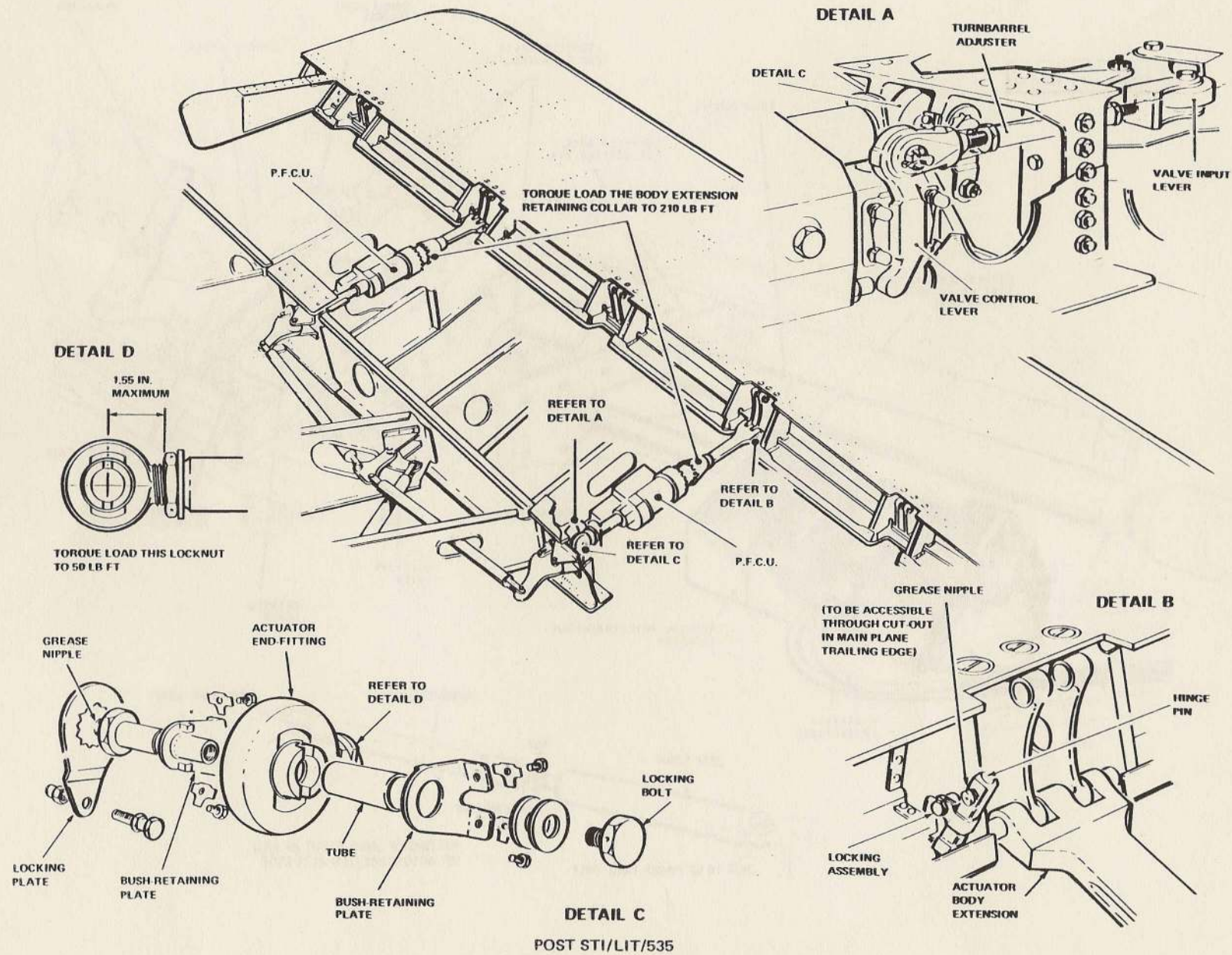

FIG. 5. P.F.C.U. INSTALLATION

◀ WASHERS ADDED IN DETAIL C ▶

RESTRICTED

HQSTC
COMMAND TEMPORARY
AMENDMENT NO 5
AP101B-1003-1A

This page to be inserted in Sect 3, Chap 4C, facing Figure 5.

DETAIL D

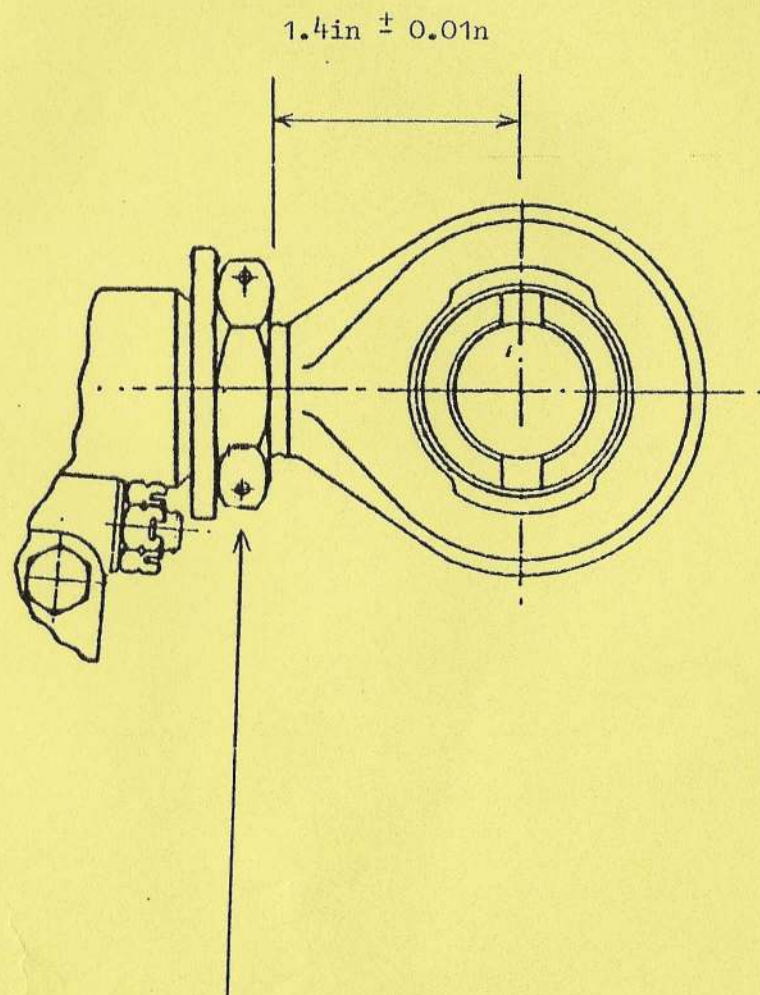

LOCKNUT TO BE TORQUE LOADED TO 80lbf ft.

HQSTC
COMMAND TEMPORARY
AMENDMENT NO 7
AP101B-1003-1A

This page to be inserted in Sect 3, Chap 4C, facing Figure 6.

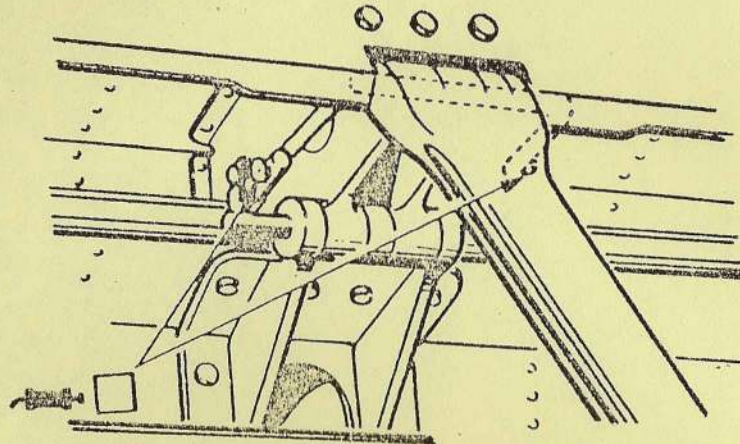

USE HYDRAULIC HAND PUMP PRESSURE IN ORDER TO
GAIN ACCESS TO THE SEVEN GREASE NIPPLES

DETAIL E

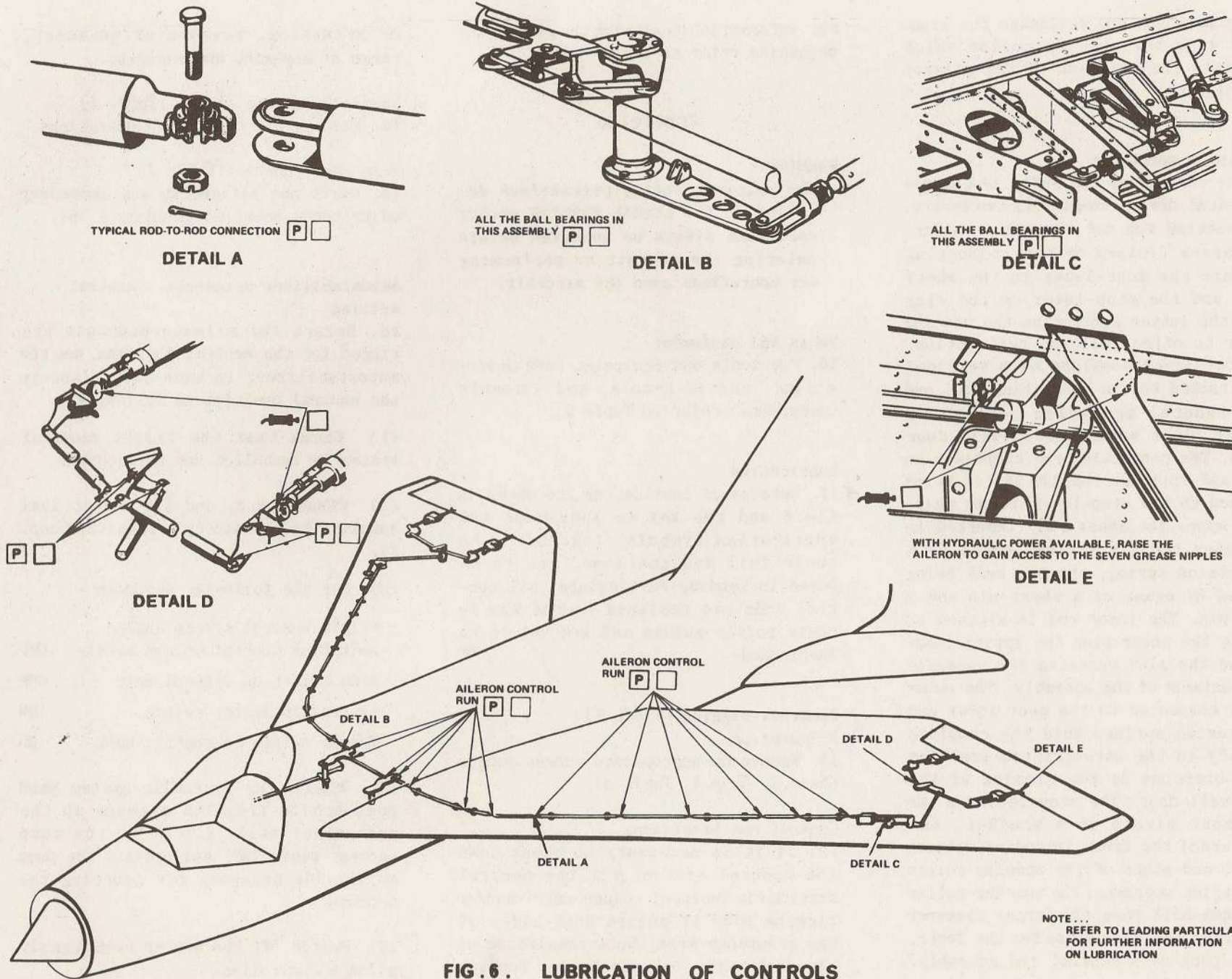

FIG. 6. LUBRICATION OF CONTROLS

◀ REDRAWN ▶

NOTE . . .
REFER TO LEADING PARTICULARS
FOR FURTHER INFORMATION
ON LUBRICATION

RESTRICTED

spring pressure and re-engage the stop-lever with the spacing collar which restricts the movement of the aileron control run.

Restrictor mechanism

9. The restrictor mechanism is a simple mechanical device comprising two levers, a connecting rod and a spacing collar. The levers (joined by the connecting rod) are the door-lever in the wheel well, and the stop-lever on the wing spar, the latter contacting the spacing collar to effect aileron restriction. The door-lever consists of a vertical arm attached to the connecting rod, and a horizontal arm which contacts a striker plate as the wheel-well door closes. The connecting rod comprises an outer and an inner rod, the latter being attached to the stop-lever on the main-plane spar. The inner rod, inserted in the outer rod, is spring-loaded by a compression spring, the two rods being secured by means of a shear-pin and a split pin. The inner rod is slotted to receive the shear-pin, the spring loading and the slot catering for possible maladjustment of the assembly. The outer rod is connected to the door lever and two tension springs hold the complete assembly in the unrestricted position until overcome by the closing of the wheel-well door. The stop-lever on the wing-spar pivots in a bracket, the upper arm of the lever intruding between the two end-stops of the spacing collar to restrict movement. The spacing collar is of dumb-bell form, the larger diameter end-pieces acting as stops for the lever, and is part of a control rod assembly.

For information on setting the restrictor mechanism refer to fig.7.

SERVICING

WARNING

The relevant safety precautions detailed on the LETHAL WARNING marker card must always be observed before entering the cockpit or performing any operations upon the aircraft.

Tools and equipment

10. For tools and equipment used in servicing, and in removal and assembly operations, refer to Table 3.

Lubrication

11. Details of lubrication are shown in fig.6 and the key to lubricant and application symbols, together with their full designations, are to be found in Leading Particulars. All control rods are designed to run dry in their roller guides and are not to be lubricated. ▶

Controls rigging (Table 1)

Preparation

12. Remove the appropriate access panels (Sect.2, Chap.4, Table 3).

Control run breakdowns

13. If it is necessary to break down the control system, fit the neutral setting rig (control column only) and/or rigging pins at points both sides of the breakdown area. Upon completion of the work carry out checks for fouling

or straining, freedom of movement, range of movement and security.

Complete rigging checks (Table 1)

14. Execute all the listed operations.

Trim range checks (Table 1)

15. Carry out all checks and necessary adjustments detailed in check 8 (B).

Autostabilizer actuators - neutral setting

16. Before the aileron controls are rigged for the neutral position, set the autostabilizers in each main plane to the neutral position as follows:-

(1) Check that the flight control system is installed and serviceable.

(2) Connect a.c. and d.c. electrical supplies to the aircraft (Sect.2, Chap.2).

(3) Set the following switches:-

Flight control system engage	
switch on control column handle	OFF
Stab switch on control unit	OFF
Instrument master switch	ON
Master switch on control unit	ON

(4) Remove the hydraulic system hand pump handle from its stowage in the port wheel-well, fit it to the pump (access panel 79P) and operate the pump to provide pressure for centring the actuator.

(5) Switch off the master switch on the pilot's controller.

RESTRICTED

This page to be inserted in Sect 3, Chap 4C, facing Table 1 - CONTROLS RIGGING

ITEM 4 - CHECKS

In both main planes insert setting pin at :-

(A) Autostabilizer actuator

and locating pins at :-

(B) Actuator lever

(C) Cradle lever assembly ensuring that
cradle lever is at 90° to spar 1.

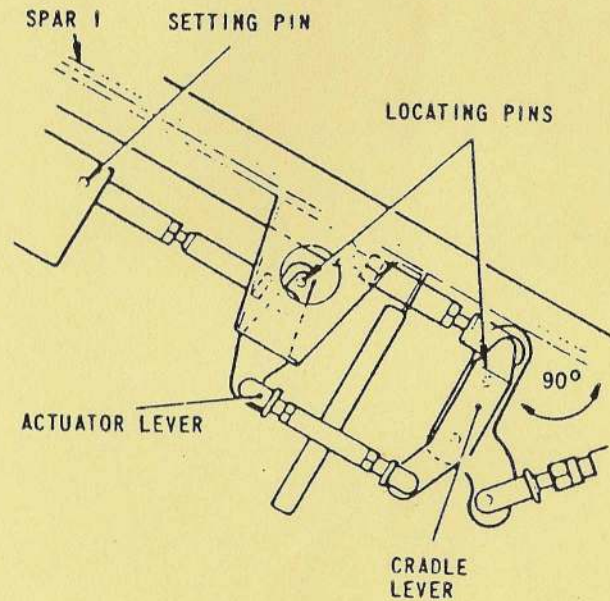

TABLE 1-CONTROLS RIGGING

CHECKS	ADJUSTMENTS IF NECESSARY	CHECKS	ADJUSTMENTS IF NECESSARY
<p>Connect hydraulic servicing trolleys to services and both controls systems, and electrical servicing trolley (Table 3) to the appropriate connections and, with power on:-</p> <p>(A) On all four p.f.c.u. remove pin connecting turnbarrel to valve input lever.</p> <p>(B) Check autostabilizers for neutral setting.</p> <p>(C) Set trim to neutral by cockpit indicator.</p> <p>(D) Stop trolleys.</p> <p>(E) Fit neutral setting rig and an inclinometer to control column.</p>	<p>1</p>  <p>(B) Refer to para. 16.</p> <p>(E) Refer to Chap. 4B for fitting instructions.</p>	<p>2</p> <p>(A) Check control column for rigging position.</p> 	<p>(A) If control column is not in rigging position operate trim switch to correct this. Trim indicator must be reset after all checks have been completed.</p>
<p>(A) Fit locating pin in non-linear gearing mechanism (access panel 265).</p> 	<p>3</p> <p>(A) If pin will not enter check lever setting at Fr. 8-9.</p>  <p>(B) If setting of lever is correct and pin will still not enter adjust control rod at non-linear gearing</p> 	<p>In both main planes insert setting pin at:-</p> <p>(A) Autostabilizer actuator and locating pins at:-</p> <p>(B) Actuator lever</p> <p>(C) Cradle lever assembly</p> 	<p>4</p> <p>(A) If pin will not enter actuator refer to para. 16.</p> <p>(B) If pin will not enter lever adjust turnbarrel at actuator.</p> <p>(C) If pin will not enter cradle lever assembly check that cradle lever is 90° to spar face, adjusting on turnbarrel if necessary. If pin still does not enter adjust last control rod on spar.</p> 

TABLE 1 - CONTROLS RIGGING CONTINUED

CHECKS	ADJUSTMENTS IF NECESSARY	CHECKS	ADJUSTMENTS IF NECESSARY
<p>(A) Check setting of aileron input levers (access panels 101A and C port and starboard).</p>	<p>(A) If setting is incorrect adjust input rod at end which projects through spar 1.</p>	<p>(A) Check ailerons for neutral position at inboard tip. (B) Set aileron p.f.c.u. to neutral using setting gauge. (C) Connect turnbarrels to aileron p.f.c.u. by inserting connecting pins.</p>	<p>(C) If necessary adjust turnbarrels until pins can be inserted without disturbing aileron or p.f.c.u. settings.</p>
<p>UNDERSIDE VIEW, PORT WING</p>  <p>2.25 IN. P.F.C.U.</p>	<p>PLAN VIEW ON PORT WING OUTBOARD</p>  <p>FORWARD LOCATING PIN ADJUST AILERON INPUT ROD HERE $\frac{5}{8}$"</p>	 <p>CONNECTING PIN TURNBARREL VALVE LEVER USE SETTING GAUGE WING-CHORD PLANE JACK C/L</p>	
<p>(A) Remove neutral setting rig and all locating and setting pins. (B) Fit aileron travel gauges (Table 3) port and starboard at aileron inboard tips. (C) Unscrew stops on control column to allow maximum column movement. (D) Disconnect inboard end of last control rod on spar 1 on both main planes. (Refer to 4(C)). (E) Start the servicing trolley and operate each control rod manually and check ailerons for fouling twisting or straining over full range of movement. (F) Connect control rods.</p>	<p>MAIN PLANE Measured at aileron inboard edge upper face HINGE CENTRE</p>  <p>+0.10 IN. 4.70 -0.10 +0.10 IN. 4.74 -0.10</p> <p>Measured at aileron inboard edge lower face.</p> <p>Note... The full range of movement may be exceeded provided it is evenly distributed up and down.</p>	<p>(A) Check operational travel on both ailerons ensuring even movement both sides.</p> <p>HINGE CENTRE Measured at aileron inboard edge upper face</p>  <p>+0.00 4.22 -0.25 IN. +0.00 4.25 -0.25 IN. Measured at aileron inboard edge lower face</p> <p>(B) Check trim range which should be not less than $\frac{1}{4}$" of aileron movement up and down and equal port and starboard.</p> <p>HINGE CENTRE Measured at aileron inboard edge upper face</p>  <p>+0.25 1.107 -0.00 IN. +0.25 1.117 -0.00 IN. Measured at aileron inboard edge lower face</p> <p>Remove servicing trolleys and travel gauges. Inspect all limit stops, control rod adjusters and turnbarrels for correct locking and where applicable correct thread engagement.</p>	<p>(A) If operational travel is incorrect, adjust control column stops. Note... If control column fouls console, adjust appropriate stop to clear foul. (B) If trim range is not equal, adjust length of trim actuator ram until balance is achieved and reset trim indicator to correspond.</p>

(6) Switch off the instrument master switch.

(7) Check for centre position, using a setting pin through the hole in the body of the actuator (fig.4). If the pin will not enter the actuator is unserviceable.

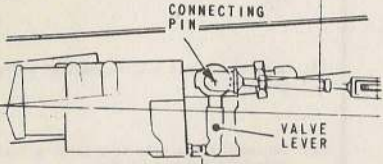
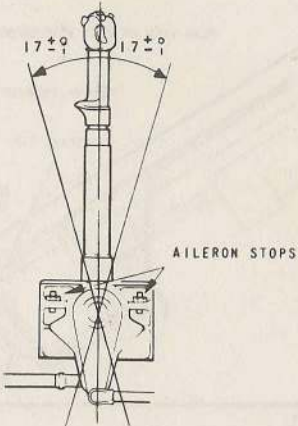
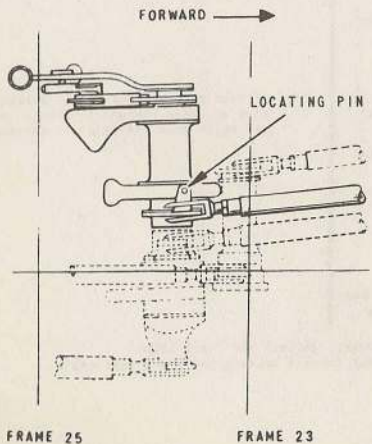
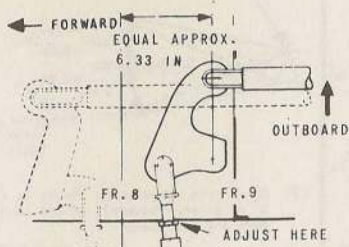
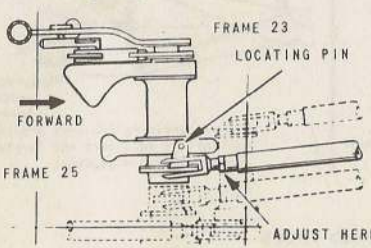
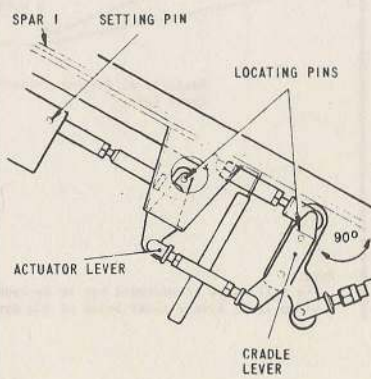
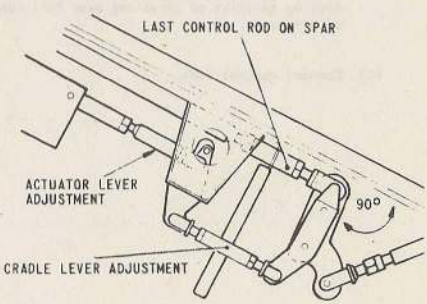
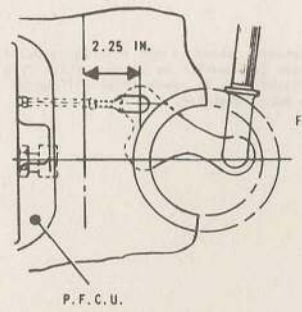
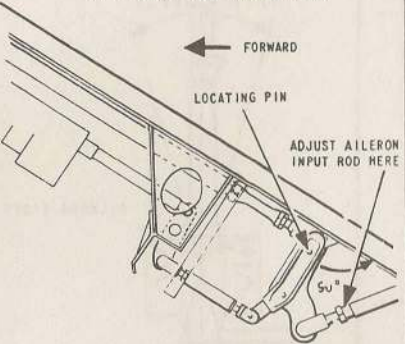
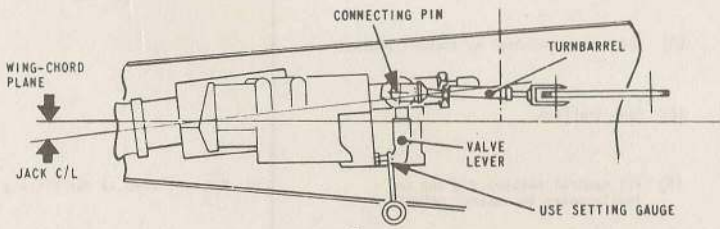
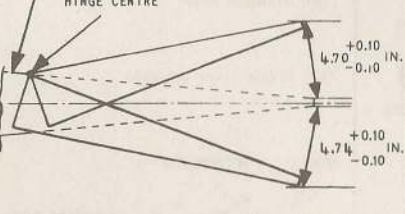
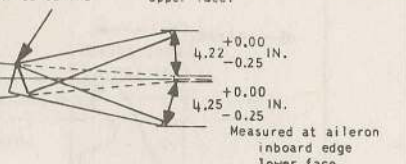
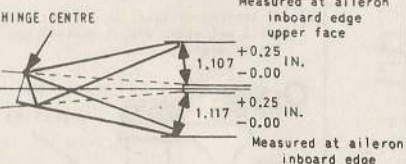
Note...

Do not leave the pin in position.

Smoothness, friction and centring checks

17. The following checks must be made whenever a replacement p. f. c. u., centring unit or torsion shaft has been fitted:-

(1) Connect hydraulic servicing trolleys to the No.1 and No.2 controls system (access panels 45P and 67P).

(2) Set the aileron controls at neutral and operate the trim switch until neutral position is indicated on the gauge.

(3) Check carefully that, when the control column is moved through its full arc of movement, consistent smoothness is present throughout the range. If perceptible harshness is felt, its source must be traced and remedied before any further checks are carried out.

(4) Using a spring balance check for friction by slowly applying sufficient force to the control column, at a point 15.5 in. from the column pivot, to initiate aileron movement from neutral. The force required must not exceed 12 oz port or starboard.

(5) Remove the spring balance.

(6) Fit the neutral setting rig and inclinometer (Chap.4B) and check for centring by displacing the control column to one extreme and allowing it to return slowly, under restraint, to the neutral position. Note the final 'hands off' position. Repeat the check, taking the control column to the opposite extreme, and note the final position. In both cases the final out-of-centre position must not exceed ± 2 deg.

(7) Remove the servicing trolleys, inclinometer and neutral setting rig.

Artificial 'feel' check

18. This check, in addition to those given in para.17, must be made whenever a replacement centring unit or torsion shaft has been fitted.

(1) Connect hydraulic servicing trolleys to the No.1 and No.2 controls system (access panels 45P and 67P).

(2) Using a tubular spring balance check that the force required to displace the control column agrees with the following table:-

TABLE 2

Artificial 'feel' check

CONTROL COLUMN ANGLE	
PORT	STARBOARD
5° 7 ± 1.5 lb	5° 7 ± 1.5 lb
15° 21 ± 2 lb	15° 21 ± 2 lb

(3) Remove the spring balance and servicing trolleys.

Checking aileron travel limitation

19. To check the aileron travel limitation:-

(1) Jack and trestle the aircraft so that the wheels are clear of the ground.

(2) Connect, and run, hydraulic servicing trolleys to the services and both controls system.

(3) Apply a pitot pressure of not less than 165 knots and retract the alighting gear.

(4) Operate the control column to port and starboard.

(5) Move the control column to port and check that aileron travel at the port and starboard wing does not exceed $8 \pm \frac{1}{4}$ deg up and down.

(6) Repeat (5) with the control column to starboard.

REMOVAL AND ASSEMBLY

P. f. c. u.

Removal

20. To remove a p. f. c. u.:-

(1) Remove access panels 101A and C, and 102A and B, from the appropriate main plane, and the outboard section of the leading edge covering the cradle lever assembly.

(2) Release hydraulic pressure from the aileron accumulators by operating the control handle (rate not to exceed one stroke between stops in five seconds).

(3) Connect a hydraulic servicing

trolley to the ground connection couplings of the controls system serving the serviceable unit, i.e. No.1 controls system for the outboard control units, No.2 for the inboard control units.

(4) Centre the autostabilizer actuators (para.16) and, using the trolley hand pump, set the controls in the neutral position.

(5) Disconnect the inboard end of the last control rod on spar 1.

(6) Release the air pressure from the hydraulic fluid reservoirs and disconnect the hydraulic connections at the control units. Blank off the pipe ends and the control unit connections.

(7) Using a torque spanner to overcome the initial tightness, unscrew the control unit body extension retaining nut. If the nut is more than hand-tight use a C-spanner (when using this spanner the aileron must be in the down position).

(8) Repeat (7) on the other control unit in the same main plane.

(9) Lift the aileron and disconnect the control unit body extension from the hinge bracket of the aileron (fig.5, detail B). The hinge pin is locked by clips secured by a 2 B.A. bolt, distance piece, slotted nut and split pin; keep these items together to avoid difficulty on reassembly. Slide the retaining nut aft, remove the 'O' ring seal and the split collar and then withdraw the body extension aft through the shroud.

(10) Remove the turnbarrel adjuster connecting the valve lever to the input lever (fig.5, detail A).

(11) Disconnect the control unit ram end-fitting from its attachment to the diaphragm in the main plane:-

(a) Remove the 2 B.A. stiffnut securing the hinge-pin locking plate and remove the locking plate.

(b) Remove the hinge-pin locking bolt.

(c) Remove the two 4 B.A. bolts and tab washers securing each bush-retaining plate.

(d) Extract the hinge-pin and remove the control unit.

(e) Clean, and examine for serviceability, the hinge-pin, tube, and the bush-retaining plates (fig.5, detail C).

Installation

21. To install a replacement control unit:-

(1) On a hydraulic test rig, fully prime the control unit and extend the ram until its position is identical with that of the unit removed.

(2) Adjust the eye-end to the same dimension as that of the unit removed. Tighten the locknut to 50 lb ft using a torque spanner. The dimension between the outer face of the locknut and the attachment pin centre must not exceed that given in fig.5, detail D.

(3) Move the aileron to its maximum up position and fit the control unit body extension to the aileron. Lock the pin, ensuring that the grease nipple is accessible through the cut-out in the main plane trailing edge, by fitting the clips and securing them with the 2 B.A. bolt, distance piece and slotted nut. Split-pin the nut.

Note...

If, during the removal operations, it has been found necessary to disconnect the control run at the bell-crank lever, ensure that the upper bearing

together with the spacer are intact in the housing and that they are not dislodged during subsequent assembly operations. (SII/Lightning-402 refers).

- ◀ (4) Position the tube through the bushes of the eye-end of the control unit and locate the two bush-retaining plates (fig.5, detail C). Position the unit in the main-plane box and fit the hinge pin. Fit and secure the locking plate to the hexagon head with the 2BA bolt, thin nut and stiff nut. Fit the locking bolt and two washers, Ref. No. 28W/9447767 to the tapped end of the hinge pin. Run the bolt finger tight and then one additional flat (SII/Lightning /535 refers). Wire lock the locking bolt. Secure the bush retaining bolts, with the 4BA special-to-type bolts, using new tab washers, Ref. No. 26DK/6230. ▶

Note...

Ensure that the correct type of bush retaining plate is fitted by reference to component Part No. and that the dowel portions of the special to type bolts are located in their respective dowel holes in the main plane diaphragm.

(5) Lubricate the control unit hinge pins.

(6) Fit the key in the body extension and connect the body extension to the control unit, ensuring that the locating key is engaged in the keyway. With the aileron in the down position, screw up the retaining nut using a C-spanner. Torque load the nut to 210 lb ft, using a torque wrench. Wire-lock the collar.

(7) Repeat (6) on the other control unit.

(8) Set the ailerons in the neutral position, displacing the relay valve of the serviceable control unit by moving the control rod at the main-plane spar in the appropriate direction.

HQ STC
COMMAND TEMPORARY
AMENDMENT NO 5
AP101B-1003-1A

This page is to be inserted in Sect 3, Chap 4C, facing page
containing paragraph 22(2)

Para 22(2) Adjust the eye-end to the same dimension
as that of the unit removed. Tighten the
locknut to 80lbf ft using the appropriate torque
spanner. The dimension between the outer face
of the locknut and the attachment pin centre
must not exceed that given in Figure 5 Detail D.

(9) Set the relay valve on the replacement control unit to the central position, using the gauge as a feeler.

- ◀ (10) Reconnect the turnbarrel adjuster to the valve lever and input bell crank. Ensuring:- a) The thicker section of the fork end (part number EB2-45-943) is connected to the bell crank. b) The thinner section of the fork end (part number EB2-45-2133) is connected to the P.F.C.U. control lever.

(11) Reconnect the hydraulic couplings, prime and bleed the system. Wire-lock the couplings.

(12) Connect a hydraulic servicing trolley to the controls system serving the replacement control unit. Operate the trolley hand pump and check, at the inboard tip and outboard horn, that no movement or distortion of the aileron occurs. If necessary, correct by adjustment on the turnbarrel. Wire-lock the turnbarrel.

(13) Connect hydraulic servicing trolleys to both controls systems and an external air supply of 16-18 lb/in² to the hydraulic reservoir air release valve (access panel 63P). Start the trolleys, and slowly operate the control rod on the wing spar to check maximum aileron up and down movement. Check carefully that no straining or fouling occurs.

(14) Set the ailerons to the neutral position and reconnect the last control rod on spar 1.

(15) Operate the control column laterally and check for correct operational movement of the ailerons (*Table 1, detail 8*).

(16) Carry out smoothness and friction checks (*para.17*), and hydraulic pressure and accumulator capacity checks (*Chap.6*).

Renewal of a defective autostabilizer actuator:-

22. To renew the actuator (*fig.4*):-

Note. . .

Do not disturb the setting of the connecting rod with the actuator ram during removal.

- (1) Remove the actuator complete with the connecting rod.
- (2) Lock the actuator ram in mid-stroke with the appropriate setting pin, and measure the distance between hole centres of connecting rod fork end and defective actuator earth end attachment (or some other suitably fixed points). Remove the connecting rod from the actuator.

(3) Lock the ram of the replacement actuator in mid-stroke. Fit and adjust the connecting rod to obtain an equal corresponding measurement to that in sub-para.(2).

(4) Fit the replacement actuator, with connecting rod, to the aircraft.

Note. . .

The rigging pin hole in the actuator lever must be aligned within one half turn of the connecting rod.

(5) With the actuator ram in mid-stroke, check that the cradle lever is at 90 deg to spar 1 datum.

(6) Remove the setting pin. Tighten the rod locknut and secure with 22 s.w.g. lockwire Ref.No.30A/9437135.

(7) Refit the earth wire.

(8) After assembly, open up the split taper pin which secures the pick-up link at one end of the actuator, and discard the warning pennant.

Jury strut

Installation (fig.4)

WARNING

Fitment of jury struts imposes a limitation on the aircraft handling as detailed in A.P.101B-1003-15. The appropriate entry must be made in the Aircraft Limitations Log (Form 703) for the attention of the pilot.

23. When fitting a jury strut in lieu of an aileron autostabilizer actuator, install the strut as follows:-

Note. . .

1. *Aileron autostabilizers must not be left with only the port or starboard actuator operable. One of the following alternatives is to be used:-*

(a) Both port and starboard actuators are to be replaced with jury struts.

(b) If one side is left fitted with a serviceable actuator it is to be inhibited by disconnecting the electrical and hydraulic power

supplies, and mechanically locked using rigging pins. Hydraulic pipelines disconnected from the serviceable actuator are to be properly blanked, locked, and leak tested before flight.

2. *The following essential actions are to be strictly observed when fitting jury struts in lieu of actuators:-*

(a) The pin centre length of the jury strut and connecting rod is to correspond exactly with that of the actuator and connecting rod.

(b) Hydraulic pipes disconnected from the removed actuators are to be properly blanked, locked, and leak tested before flight. Electrical connections are to be stowed.

(c) Remaining channels are to be left operative. The dither level is to be checked and adjusted if necessary.

(1) Connect the connecting rod assembly to the actuating lever and insert a rigging pin in the locating hole in the lever.

(2) Screw the jury strut on to the connecting rod assembly aligning the earth connection hole in the strut with the corresponding hole in the mounting bracket.

(3) Bolt the jury strut to the mounting bracket, nut to be finger-tight only, and secure with a split pin.

(4) Check the strut thread engagement in the connecting rod for safety and, if satisfactory, tighten the locknut and secure with locking wire, 22 s.w.g. Ref.No.30A/9437135.

(5) Remove the rigging pin from the lever.

Ailerons

Removal and assembly

24. For removal and assembly of the ailerons refer to Chap.2.

TABLE 3
Tools and equipment

Ref. No.	Part No.	Description	Application/remarks
26DK/95778	EB3.88.143	Pin, setting control column and rudder bar	
26DK/95288	EB3.88.4685	Stand, storage, aileron	
26DK/95127		Pins, locating	Controls rigging
26DK/95134		Pins, setting	Autostabilizer setting
1A/1275138		Balance, spring, 0-30 lb	Artificial 'feel' check
1H/118		Balance, spring, tubular	Smoothness, friction and centring checks
27FK/2779		Assembly, torque adapter	P.F.C.U. removal and assembly
26DK/95114	EB2.88.2009	'C' spanner, aileron power control tail-piece retaining nut	Removal and replacement of tail-piece with control unit installed in the aircraft
26DK/95772	EF2.88.309	Gauge, aileron travel, port	
26DK/95773	EF2.88.310	Gauge, aileron travel, starboard	
27FK/2780		Assembly, torque adapter	Removal/replacement and bay servicing of aileron P.F.C.U.
4F/3603		Trolley, hydraulic servicing Mk.3	c/w No.1, 2, 3 and 4 conversion kits
4F/3786 or		Trolley, electrical servicing	15kVA/10kW electrically driven
4FE/4257			
4FE/3761 or		Trolley, electrical servicing	15kVA/10kW I.C.E. driven
4FE/5147			
6C/2202		Sets, test, pitot static	
6C/973		Adapter, Mk.9 pitot static system	Use with 6C/2202

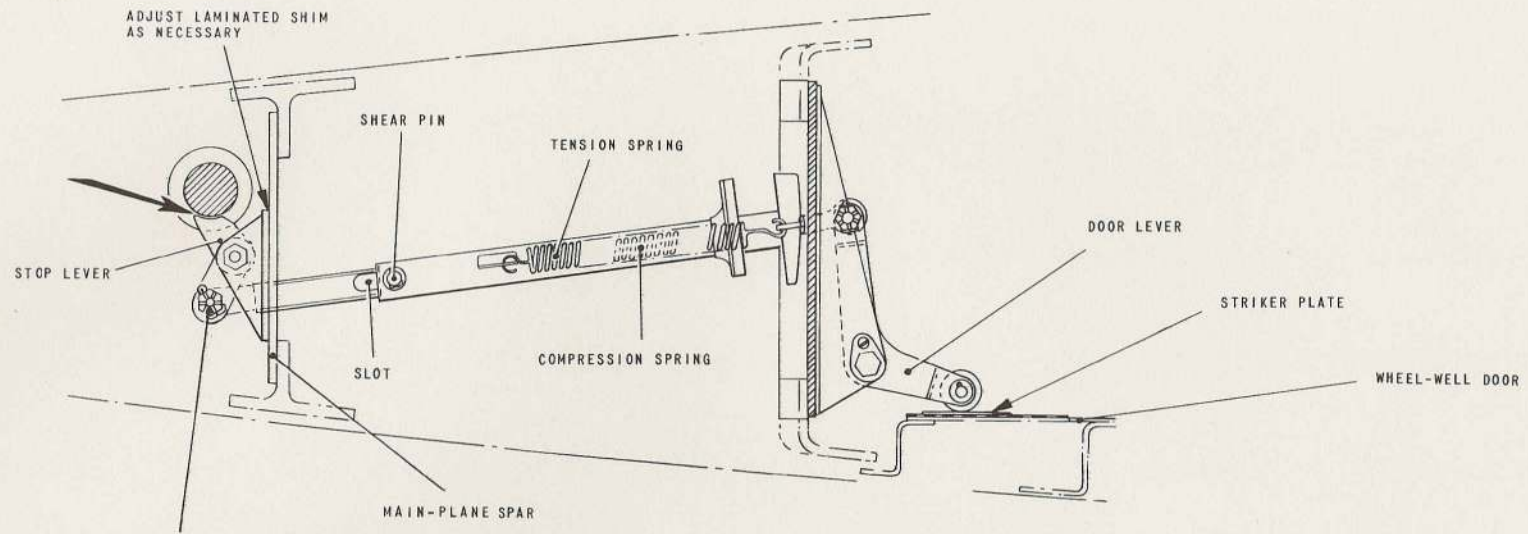

WITH U/C DOOR IN CLOSED POSITION AND LEVER IN RESTRICTED POSITION ADJUST CONNECTING ROD SO THAT A COMPRESSION OF 0.10 IN. IS NEEDED TO ALIGN HOLE IN ROD WITH HOLE IN LEVER

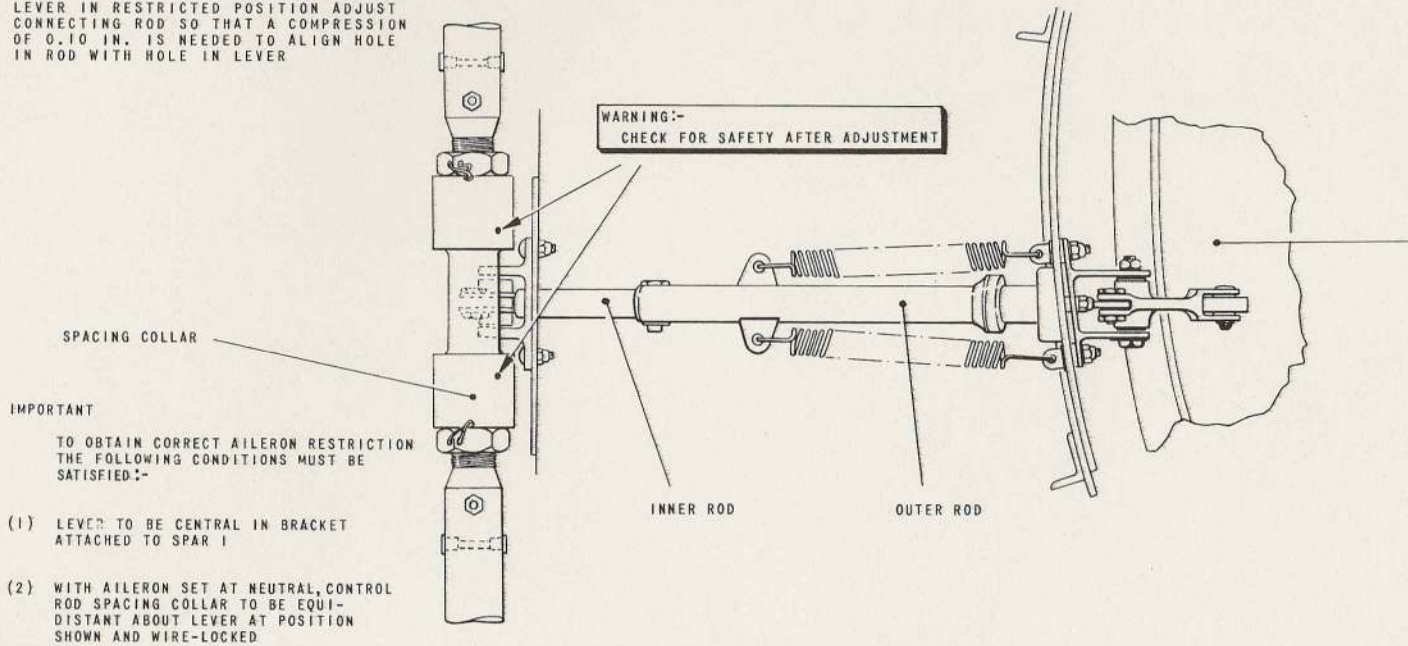

FIG.7. AILERON TRAVEL RESTRICTOR

This file was downloaded
from the RTFM Library.

Link: www.scottbouch.com/rtfm

Please see site for usage terms,
and more aircraft documents.

