

Chapter 5 ALIGHTING GEAR

LIST OF CONTENTS

DESCRIPTION	Para.	DESCRIPTION	Para.	DESCRIPTION	Para.
General information ... ..	1	Adjusting the main undercarriage door latches ... ..	23	Assembly... ..	40
<b>Main undercarriage</b>		Adjusting the main undercarriage door-jack override ... ..	24	<b>Shock-absorber strut fairing</b>	
General information ... ..	3	Adjusting the microswitches		Removal ... ..	41
Wheel-well doors... ..	4	Main undercarriage fixed-fairing... ..	25	Assembly... ..	42
Door-locking mechanism... ..	6	Main undercarriage latch unit ... ..	26	<b>Radius rod</b>	
Master latch unit ... ..	7	Main undercarriage radius rod ... ..	27	Removal ... ..	43
Microswitch latch unit... ..	9	Nose undercarriage ... ..	28	Assembly... ..	44
Lock-indicator microswitches... ..	11	Wheel-well door and fairing clearances... ..	29	<b>Undercarriage strut</b>	
Shock-absorber fairing... ..	12	Main undercarriage clearances ... ..	30	Removal ... ..	45
<b>Operation</b>		Adjusting the main undercarriage sequence valves		Assembly... ..	46
Raising ... ..	13	Main retraction jack... ..	31	<b>Wheel-well door</b>	
Lowering... ..	14	Main door jack... ..	32	Removal ... ..	47
Emergency lowering ... ..	15	Wheel-well door - manual release ... ..	33	Assembly... ..	48
<b>Nose undercarriage</b>				<b>Nose undercarriage</b>	
General information ... ..	16			<b>Wheel</b>	
Locks ... ..	17			Removal ... ..	49
◀ Nose undercarriage doors ... ..	18 ▶			Assembly... ..	50
Forward door operating mechanism ... ..	19			<b>Retraction jack</b>	
				Removal ... ..	51
				Assembly... ..	52
				<b>Undercarriage strut</b>	
				Removal ... ..	53
				Preparing a replacement strut ... ..	54
				Assembly... ..	55
				<b>Up-lock jack</b>	
				Removal and assembly... ..	56
				◀ Nose undercarriage doors ▶	
				Removal ... ..	57
				Assembly... ..	58

REMOVAL AND ASSEMBLY

LIST OF TABLES

DESCRIPTION	Table
Tools and equipment ... ..	1
Major components... ..	2

continued...

LIST OF ILLUSTRATIONS

	Fig.		Fig.		Fig.
Main undercarriage assembly ... ..	1	Main undercarriage fixed-fairing		Main undercarriage strut - removal	
Wheel-well doors ... ..	2	microswitch settings ... ..	10	and assembly ... ..	16
Master door-latch mechanism ... ..	3	Adjusting the main undercarriage		Nose retraction jack override... ..	17
Microswitch latch mechanism ... ..	4	sequence valves ... ..	11	Nose undercarriage - removal and	
Nose undercarriage ... ..	5	Main retraction jack override... ..	12	assembly ... ..	18
Nose undercarriage locks ... ..	6	Shock-absorber fairing - removal and		Nose undercarriage doors -	
Wheel-well door latch hook clearances.	7	assembly ... ..	13	removal and assembly ... ..	19
Wheel-well door latch adjustment ... ..	8	Radius rod - removal and assembly ... ..	14	Main undercarriage lubrication	
Wheel-well door and fairing		Strut and radius rod - piping and		points ... ..	20
clearances ... ..	9	clipping details ... ..	15	Nose undercarriage lubrication points.	21

LIST OF APPENDICES

	App.
Brake control cable ... ..	1

## DESCRIPTION

## General information

1. The alighting gear comprises two main-undercarriage units, retracting outward into the main planes, and one nose-undercarriage unit, retracting forward into the fuselage. When the alighting gear is retracted, the main-plane and fuselage apertures are closed by flush-fitting fairings and doors. All three units are raised and lowered by pressure from the services hydraulic system and controlled electrically from a selector unit in the cockpit. The undercarriages and fairing doors are locked in the raised and lowered positions by mechanical, hydraulic or hydraulically-operated locks; micro-switches, incorporated in the undercarriage mechanism, signal a cockpit indicator when each unit is correctly locked, up or down. For details of the associated hydraulic and electrical services refer to Chap.6, and Sect.6, Chap.5, respectively. For details of alighting gear components refer to the relevant A.P. listed in Table 2.

2. In the event of failure in the normal hydraulic supply, or of electrical failure, the alighting gear can be lowered by use of the emergency-lowering handle (Chap.11). This operates a mechanical selector valve to divert pressure from No.1 controls hydraulic system into the alighting gear 'down' lines. The alighting gear cannot be normally retracted below  $165 \pm 5$  knots I.A.S. as a pitot-operated pressure switch renders the UP selection inoperative below this speed; in an emergency, this restric-

tion can be overcome by twisting the knob of the selector lever as far as it will go in a clockwise direction and selecting UP in the normal manner.

## MAIN UNDERCARRIAGE

## General information (fig.1)

3. Each main undercarriage comprises an oleo-pneumatic shock-absorber strut, a knuckle-type radius rod incorporating the strut down-lock mechanism, and a hydraulic retraction jack. The strut pivots about a pin fitted into the undercarriage pivot bracket which is bolted between spars 3 and 4 in the main-plane structure. The pivot bracket incorporates a detachable saddle-block which permits removal and assembly of the strut. The radius rod is connected between the lower end of the strut casing and a bracket on main-plane rib 11B. The crank lever which connects the radius rod to the bracket forms one attachment for the hydraulic jack, the other end of which is attached to a lug on the strut above the pivot axis. Each strut incorporates a cantilever axle fitted with a single wheel, a tubeless tyre, a plate-type brake unit and a Maxaret unit.

## Note...

*To safeguard personnel, and the aircraft, from the effects of possible tyre explosion due to high wheel/tyre bead temperature, three fusible thermal-relief plugs are incorporated in each wheel; should the critical temperature be exceeded, the fusing medium inside the plugs*

*will melt and the affected tyre deflate.*

## Wheel-well doors (fig.2)

4. Each door is of conventional double-skinned construction and is hinged to the main-plane structure. Brackets at three positions around the door inside edge carry eccentrically-mounted rollers, which are engaged by the hooks of the door locking mechanism (para.6) when the undercarriage is retracted. Two moulded pads, near the forward hinge, contact the strut in its retracted position and, through the door rollers and locking mechanism, support the strut if its normal up-lock fails.

5. The door is suspended on three hinges at its inboard edge, the door component of the centre hinge incorporating a lever to which the door operating jack is attached. Two transverse pins, in the same lever, operate the main jack sequence valve through its associated spring-loaded trip mechanism; the valve and trip mechanism are mounted in a bracket secured to the main-plane structure above the centre hinge. A striker plate located on the inner skin of the port door, contacts the door-lever of the aileron movement restriction mechanism (Chap.4C), when the door is closed.

## Door-locking mechanism (fig.1)

6. The locking mechanism for each door comprises a hydraulically-operated master latch unit, and two associated slave latch units operated from the master unit through rod and lever linkages and assisted in the locked up

RESTRICTED

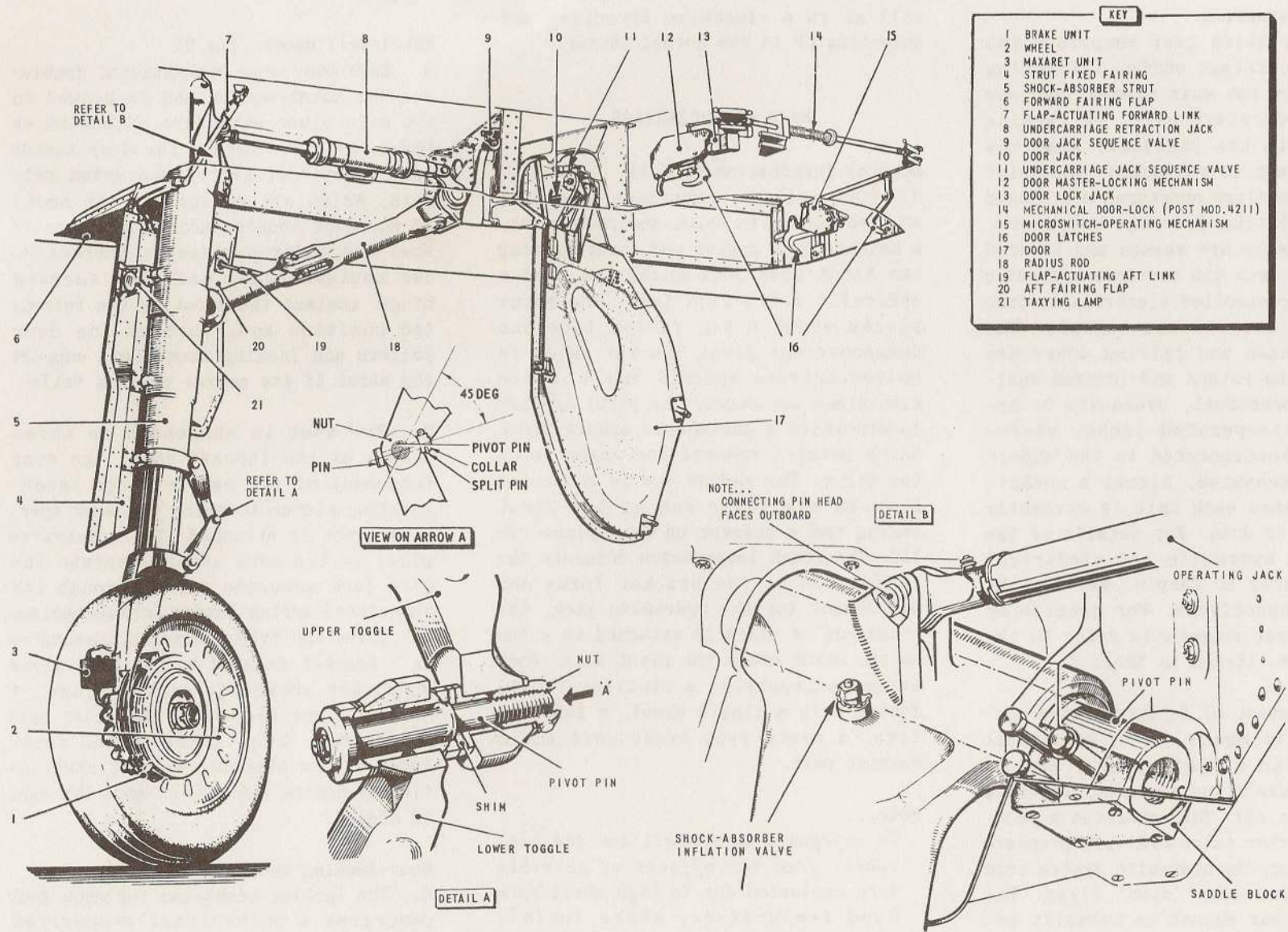

FIG. 1. MAIN UNDERCARRIAGE ASSEMBLY

MINOR AMENDMENT

RESTRICTED

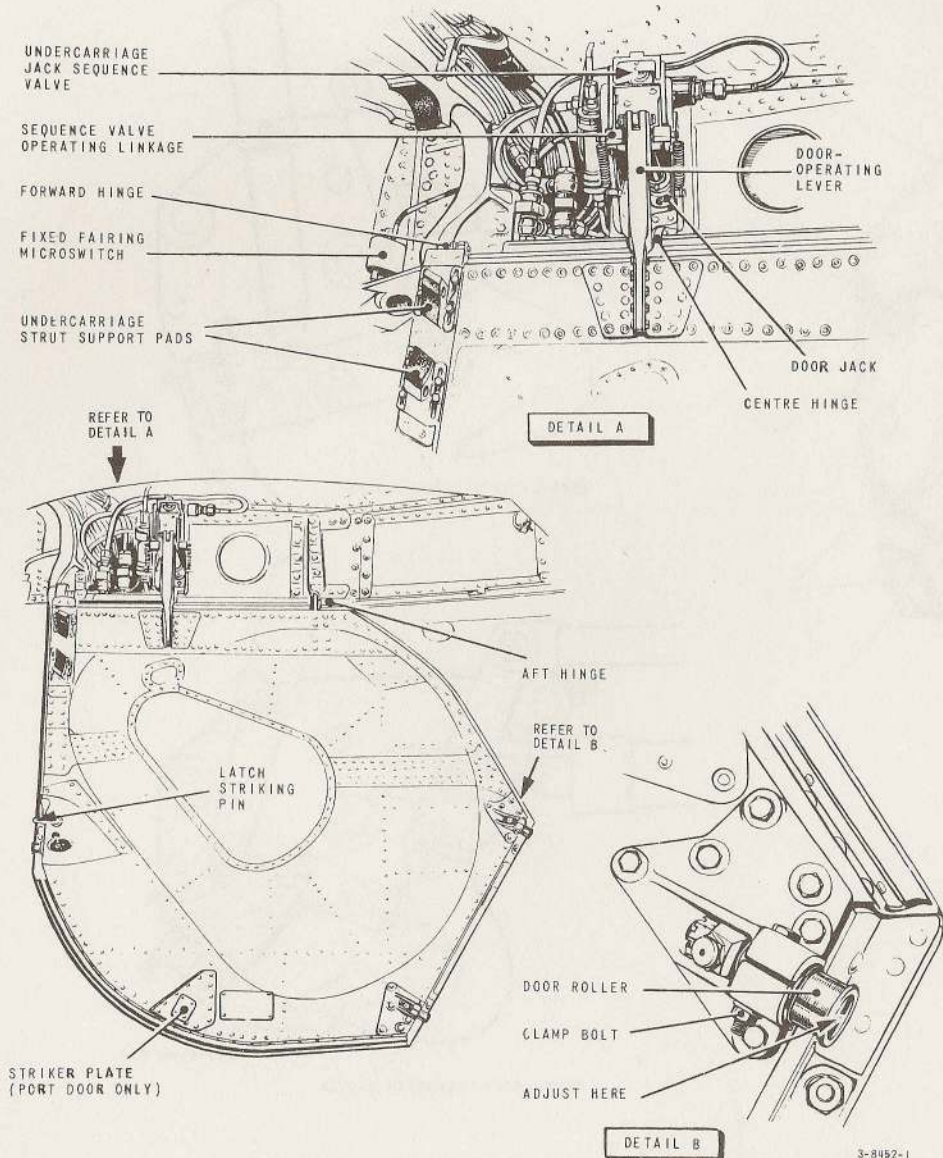

Fig.2. Wheel-well doors

position by a compression spring assembly.

▶ ◀ One of the slave units incorporates a microswitch which is in circuit with the undercarriage position indicator, and the other slave unit is a simple mechanical lock. All three units are mounted on the wheel-well wall and incorporate hooks which engage the rollers on the door when it is closed. A manual-release stud, fixed to the latch hook of the microswitch unit (fig.4), enables the locking mechanism to be released manually from outside the wheel bay during servicing; access is gained through a small panel in the undersurface of the main plane, directly below the unit.

**Master latch unit (fig.3)**

7. The unit consists of two keep plates, enclosing a hook lever and a trigger assembly connected together by a spring-loaded toggle link, and pivoted on pins passing through the keep plates. The hook lever rotates about its pivot when moved by a hydraulic jack. The upper end of the hook is attached to the connecting link to the slave units, and an adjustable stop limits the movement of the hook towards the locked position. The trigger assembly comprises two levers on a common pivot, the angular relationship between them being fixed by two adjusting bolts, one in each lever. The upper lever forms one component of the toggle link and is connected to the compression-spring plunger.

8. When the latch is open, the toggle link is in its locked condition and prevents the jack moving the hook arm

RESTRICTED

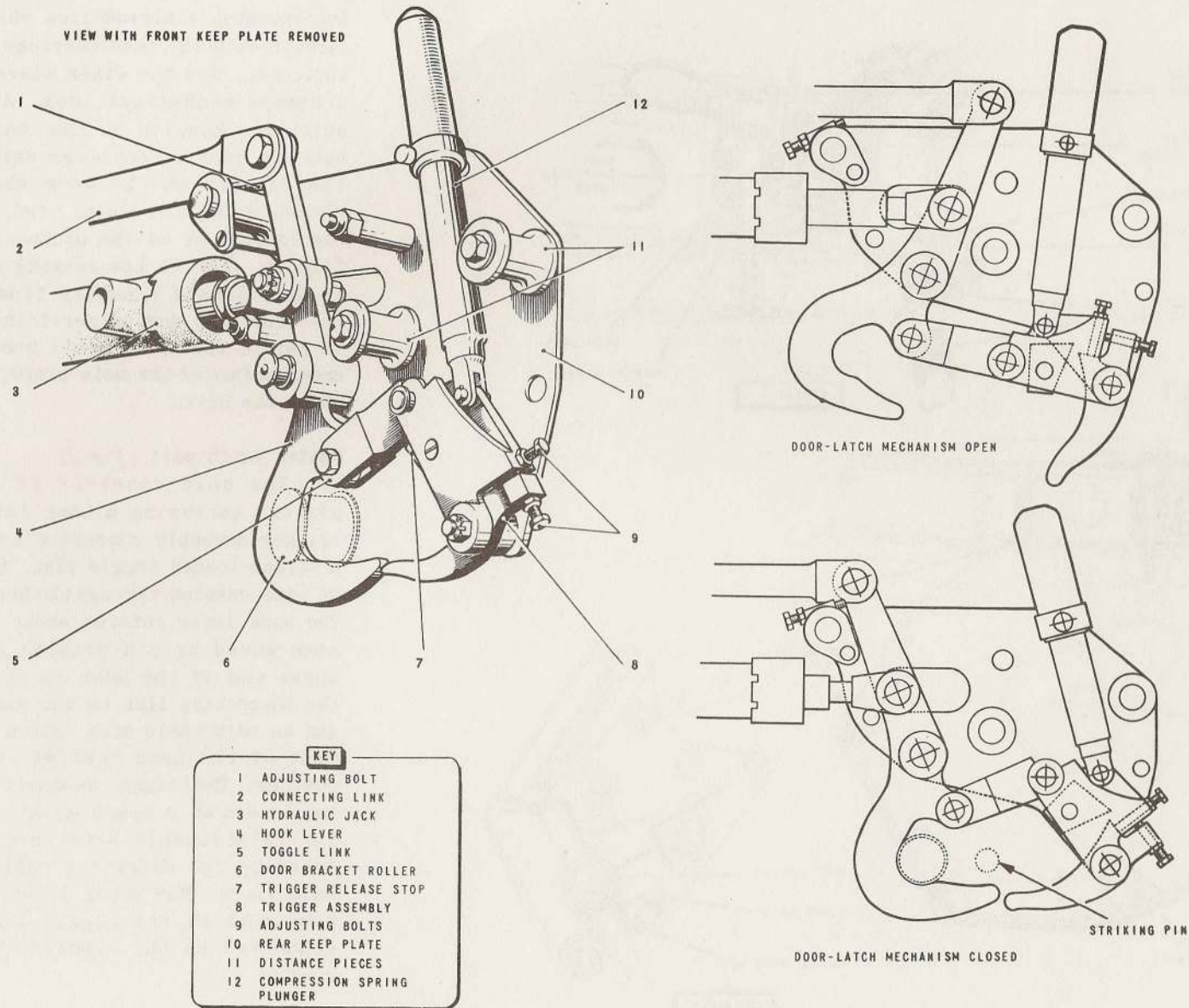

FIG. 3. MASTER DOOR-LATCH MECHANISM

3-8453-1

RESTRICTED

even though hydraulic pressure is applied. As the door closes, a pin near the door roller strikes the trigger release stop and breaks the toggle lock. The jack then retracts to move both hook arm and trigger towards each other to engage the roller and striking pin respectively. When the undercarriage is selected down, the jack draws the hook and trigger out of engagement with the roller and pin, and straightens the toggle linkage which is forced over-centre by the compression-spring plunger. If the spring fails, the falling striker pin will contact the horn of the trigger assembly and ensure that the toggle lock engages.

#### Microswitch latch unit (fig.4)

9. The unit is assembled between two keep plates and comprises a latch hook, a microswitch and the microswitch operating mechanism. The latter consists of a spring-loaded plunger connected by a linkage to two independently-mounted levers. The linkage is arranged so that movement of either lever will result in only partial retraction of the plunger, but movement of both levers will retract it fully. Plunger extension is restricted by stops which limit the movement of the levers. The microswitch is operated by a trip lever, interposed between the plunger and the microswitch button, which is moved by a cam on the plunger as the latter retracts.

10. The microswitch operating mechanism is actuated by the joint action of the latch hook, and a striking block on the wheel-well door, each of which contacts one of the microswitch operating levers.

If the hook fails to engage, or the door fails to close, the microswitch is not operated and the red lamps of the cockpit indicator remain lit.

#### Lock-indicator microswitches

11. Three microswitches are fitted to each main undercarriage, two to indicate correct retraction and locking, and one to indicate correct locking in the down position. The up microswitches are fitted, one in the latch mechanism (para.9) and one on main-plane rib 11B (fig.2), the latter being tripped by the fixed fairing when the strut is fully retracted. The electrical circuits of these two switches are arranged so that the cockpit indicator lights will be extinguished only when both strut and door are fully retracted and locked. The down microswitch is fitted to the radius rod and is operated by the main down-lock only when the latter is fully engaged. For further details of the microswitch electrical circuits and cockpit indicator functioning, refer to Sect.6, Chap.5.

#### Shock-absorber fairing (fig.1)

12. The complete fairing assembly consists of a fixed fairing, with two fairing flaps, hinged to its top edge. Seven adjustable attachment bolts are carried in brackets bolted to the fixed fairing and screw into tapped lugs on the strut casing. One of the brackets incorporates an adjustable striker pin which operates the wheel-well door-jack sequence valve. The fixed-fairing structure accommodates a taxiing lamp (Sect.6, Chap.8). The angular movement of the two fairing flaps is controlled during

retraction and lowering by adjustable actuating links, one to each flap. The link to the forward flap is connected to a bracket on the undercarriage bay roof; the link to the aft flap is connected to the lower component of the radius rod. Support of the forward flap in the fully retracted position is provided by the lip of a wedge-shaped casting, attached to the inner face of the flap, engaging an adjustable claw on the strut pivot block (para.3), during the final degrees of strut movement.

#### Operation

##### Raising

13. When an UP selection is made, hydraulic pressure is applied to the radius rod lock jack, and through the retraction jack sequence valve to the retraction jack (fig.1). After the lock is withdrawn the jack begins to extend. Initially the jack body moves aft and rotates the crank lever, which breaks the radius rod and, through the latter, begins to lift the shock-absorber strut. As the strut rises, the jack ram attachment lug at the top approaches its maximum leverage and the extending jack applies sufficient force to raise the strut completely. Final movement of the strut operates the door jack sequence valve (fig.1), diverting hydraulic fluid pressure to the door retraction jack and the master latch jack. The door jack retracts to start closing the door and the initial movement of the latter operates the undercarriage jack sequence valve to block the main jack up line thus imposing a hydraulic lock to maintain the strut in its re-

RESTRICTED

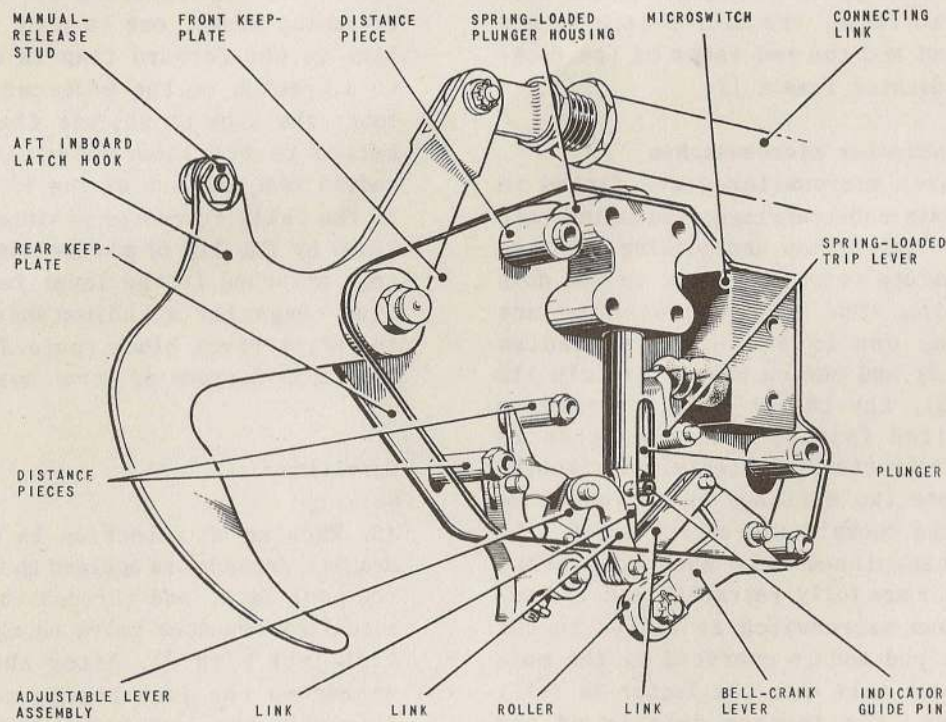

WHEEL-WELL DOOR OPEN

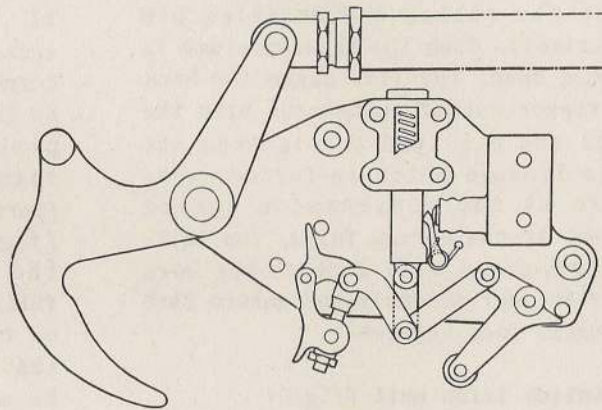

WHEEL-WELL DOOR CLOSED AND LOCKED

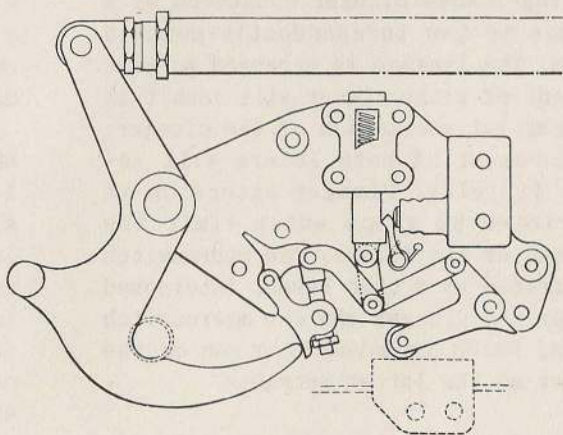

INDICATOR GUIDE PIN POSITION

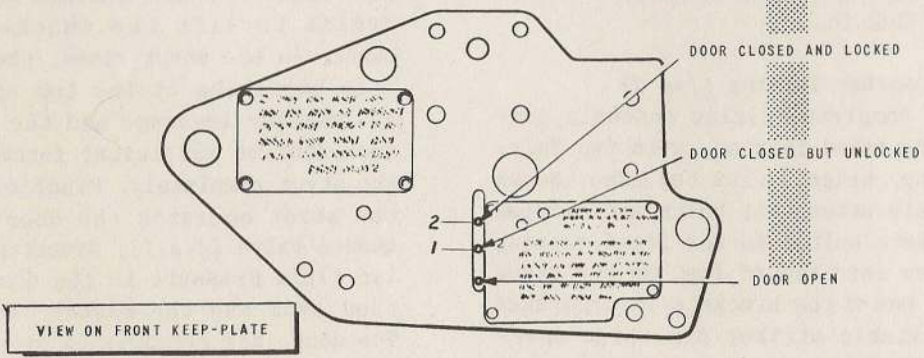

FIG. 4. MICROSWITCH LATCH MECHANISM

3-8454-1

RESTRICTED

tracted position. When the doors are fully closed the latches engage (para.6), assisted by the compression spring assembly.

#### Lowering

14. Selecting the undercarriage down applies hydraulic pressure to the door lock jack, the door jack and the main jack; at the same time pressure in the radius-rod lock jack is released allowing the lock to extend due to an internal spring. The door locks are withdrawn permitting the door jack to extend and open the door. The final few degrees of door movement operates the main retraction jack sequence valve which releases the hydraulic lock in the up line, permitting pressure in the down line to retract the jack and lower the strut. The door jack is locked down by its internal lock and the main strut is locked when the spring-loaded radius-rod lock rides over and engages behind its latch.

#### Emergency lowering

15. The emergency handle, to the left of the ejection seat, is operated by depressing the release button marked U/C, and pulling the handle up to its full extent. The handle is connected by cables to the emergency selector which, when operated, directs No.1 controls system hydraulic pressure to lower the alighting gear. After the emergency system has been used the emergency selector and handle must be manually reset. For details refer to Chap.6 and 11.

### NOSE UNDERCARRIAGE

#### General information

16. The nose undercarriage comprises a single oleo-pneumatic shock-absorber strut with a single unbraked wheel and tubeless tyre. The strut pivoted about a hollow pin supported in port and starboard brackets between fuselage frames 9 and 13. Access panels in the fuselage skin permit removal or insertion of the pin. The strut is retracted by a hydraulic jack connected between a bracket on frame 13 and an integral lever on the strut body adjacent to the pivot pin. Positive locking is provided for the strut in both extended and retracted positions. An internal stop prevents the nose-wheel castering through more than 340 deg. Hydraulic shimmy damping and automatic wheel centring during retraction are provided by the shimmy damper and centring unit, secured to the strut. When the undercarriage is retracted, the fuselage

aperture is closed by three flush-fitting doors. For shock absorber inflation and shimmy-damper-accumulator charging refer to para.21 and Chap.6 respectively.

#### Locks (fig.6)

17. The strut is locked in both up and down positions by the spring-loaded plunger in its upper end. The plunger engages a hole in either the up- or down-lock brackets as appropriate. The brackets are interconnected by a quadrantal wear plate, along which the spring-loaded plunger slides, under the pressure of its spring, until one or other of the locking holes is reached and the spring forces the plunger into engagement with the hole. The lock is disengaged in each case by a hydraulic jack, fitted in line with the locking hole, which extends to push the plunger beyond the surface of the wear plate and leave the strut free to pivot. Each hydraulic jack incorporates a switch which operates the cockpit indicator when the strut is correctly locked.

#### WARNING

**When an adaptable tow bar has been used for towing purposes and the shear pin has fractured during the tow, a retraction test must be carried out to ensure correct functioning of the nose undercarriage lock plunger.**

#### Nose undercarriage doors (fig.5)

18. The nose undercarriage doors are entirely mechanical in operation and are automatically controlled by movement of the undercarriage. The rear door pivots forward on two hinges supported by the uplock bracket, and is connected to the strut by two adjustable links. The forward doors are suspended on hinges, two to each door, secured to the nose wheel port and starboard beams. The doors are operated simultaneously by a mechanism in the wheel well, which is actuated by the retraction of the strut.

#### Forward door operating mechanism (fig.5)

19. The mechanism consists basically of a torque shaft assembly, two adjustable rods and two tension springs. The torque shaft is supported in bearings in the fuselage structure and embodies four levers all pointing forward. The inner levers are interconnected by a pin which supports a roller. The outer levers provide attachment for the struts and springs which are connected to the door aft hinges and to anchor bolts through frame 7 respectively. The springs are arranged to hold the doors in the open position. During the last few degrees of undercarriage retraction, a roller guide bracket, secured to the

RESTRICTED

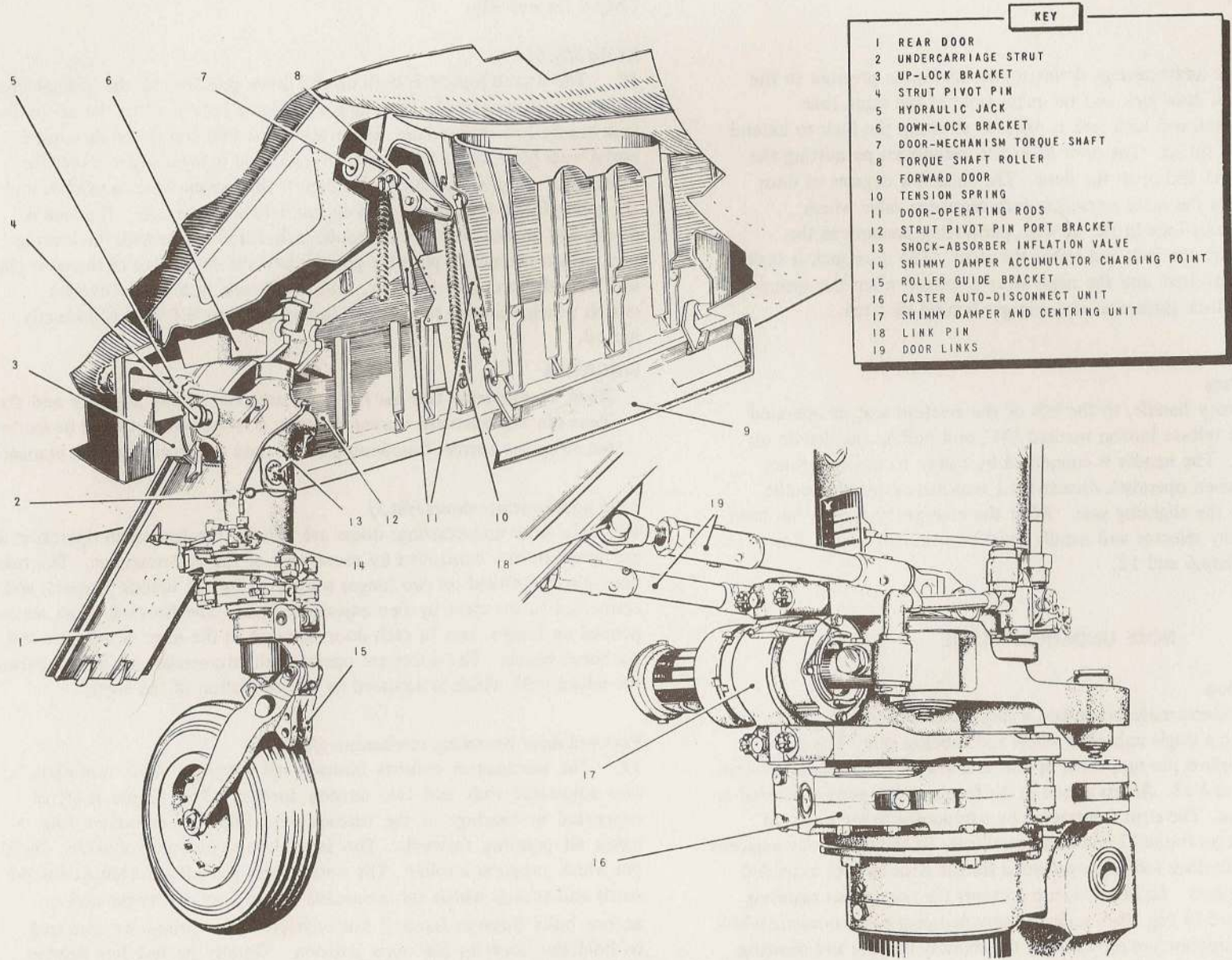

FIG. 5. NOSE UNDERCARRIAGE

3-8455-1

RESTRICTED

wheel fork of the undercarriage strut, contacts the roller. This rotates the torque shaft to pull the doors shut and at the same time tension the springs. Initial movement of the undercarriage during lowering allows the springs to contract and open the doors.

### SERVICING

#### WARNING

1. The relevant safety precautions detailed on the LETHAL WARNING marker card must always be observed before entering the cockpit or performing any operations upon the aircraft.

2. Undercarriage ground locks are to be fitted at all times during servicing other than during undercarriage functional checks.

#### Lubrication

◀ 20. Details of lubrication of main and nose undercarriage are shown in fig.20 and 21 respectively. The key to lubricant and application symbols, together with their full designations, are to be found in Leading Particulars. ▶

#### Tools and equipment

20A. For tools and equipment used in servicing and removal and assembly operations refer to Table 1.

#### Filling and inflating the shock absorbers

21. The following procedure applies to either main or nose undercarriage struts. For inflation pressures refer to Sect.2, Chap.2. The inflation valve for the main undercarriage strut is visible at the top of the strut casing,

and the nose-strut inflation valve is beneath a detachable circular panel on the front of the strut casing.

To fill and inflate a strut:-

(1) Jack and trestle the aircraft (Sect.2, Chap.4) and fit the wheel covers (Sect.2, Chap.1).

(2) Attach the wheel jacking adapter and position the correct jack, appropriate to the strut being serviced (Sect.2, Chap.4).

(3) Remove the blanking cap from the inflation valve and, with the valve held open or removed, raise the lifting jack slowly to fully collapse the shock absorber.

(4) Remove the lifting jack.

(5) Connect an oil-replenishing rig Ref.No.26DE/95162 to the inflation valve.

(6) Pump oil into the shock absorber until the strut is fully extended and afterwards continue pumping until the oil is pressurized to 1000 lb/in<sup>2</sup>.

(7) Release the pressure and, using the lifting jack, fully collapse the shock absorber with the inflation valve held open or removed. Drain excess fluid into a suitable container.

(8) Repeat (6) and (7) twice.

(9) Fit, or close, the inflation valve and connect an inflation adapter.

(10) Remove the lifting jack and adapter and charge the shock absorber with com-

pressed air to the correct pressure (Sect.2, Chap.2).

(11) Refit the blanking cap and the valve access panel (nose only), and lower the aircraft to the ground.

#### Setting the main undercarriage door stops

22.

(1) Jack and trestle the aircraft (Sect.2, Chap.4).

(2) Connect a ground servicing trolley to services No.1 hydraulic ground test connections.

(3) Connect a ground d.c. electrical supply.

(4) Remove the latch striker-pin from the door and slacken the door-stop locknuts.

(5) Disconnect the door jack from the door and support it clear of the hinge.

(6) Close the door manually and hold it hard against its stops.

(7) Adjust the forward stop, using a screwdriver through the hole in the door skin, until the leading-edge is 0.050±0.020 in. inside the main-plane contour.

(8) Adjust the two aft stops until the door trailing-edge is flush with the main-plane skin; at no point must the trailing edge be inside the skin contour.

#### Note...

When fitting a replacement door (7) and (8) must be satisfied even if it is necessary to apply force to the door.

(9) Connect the door jack and refit the striker pin.

(10) Clamp the strut-operated door-jack sequence valve, ensuring that the clamp will not foul when the strut is fully retracted.

(11) With the ground lock in position close the door, using the hand pump, checking for fouls.

(12) With the door closed and locked and pressurized to 3000 lb/in<sup>2</sup> check:-

(a) That the settings (7) and (8) are maintained.

(b) That the door rollers (*para. 23*) and the latch-unit microswitch (*para. 26*) settings are correct.

**WARNING**

It is essential, following a break-down of, or alteration to, the port door, to check the aileron movement restriction (*Chap. 4C*).

(13) Open the door. Remove the valve clamp and the ground lock.

(14) Fully retract the undercarriage, checking for fouls and correct functioning and ensuring that the correct clearances are maintained (*para. 29 and 30*).

(15) With the undercarriage fully retracted and pressurized to 3000 lb/in<sup>2</sup> check that the settings (7) and (8) are maintained, that the inboard edge of the door is 0.030 in. inside the fixed fairing contour (*para. 42*) and that the correct gaps are maintained at all points (*fig. 9*).

(16) Carry out a functioning test (*Chap. 6*).

**Adjusting the main undercarriage door latches**

**Note...**

*Before commencing these adjustments it is essential that the door jack override is correctly adjusted (para. 24).*

**23.**

(1) Jack and trestle the aircraft (*Sect. 2, Chap. 4*).

(2) Connect a ground servicing trolley to services No. 1 hydraulic ground test connections.

(3) Connect a ground d.c. electrical supply.

(4) With the ground locks in position

ILLUSTRATION SHOWS DOWN-LOCK MECHANISM.  
UP-LOCK MECHANISM IS SIMILAR.

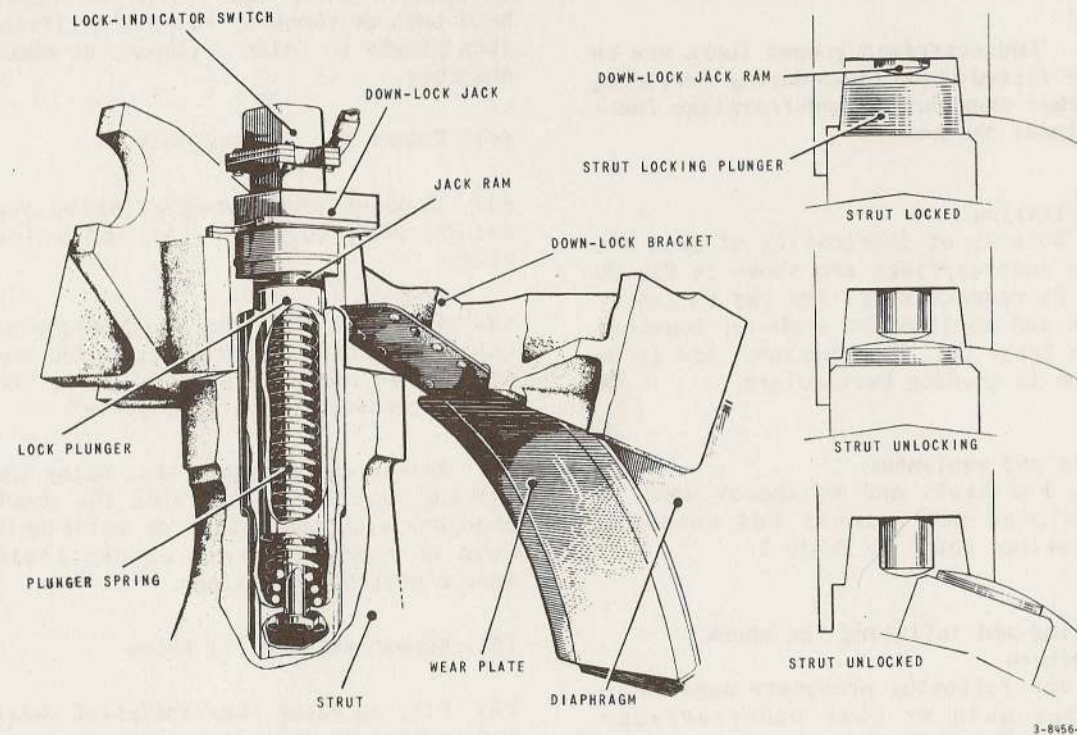

Fig. 6. Nose undercarriage locks

clamp the door-operated main-jack sequence valve.

(5) ▶ ◀ Compress the spring on the door-lock assembly and remove the screwed nipples and spokes from the spring retaining collar. Relieve spring tension slowly.

(6) Isolate the master latch-unit from

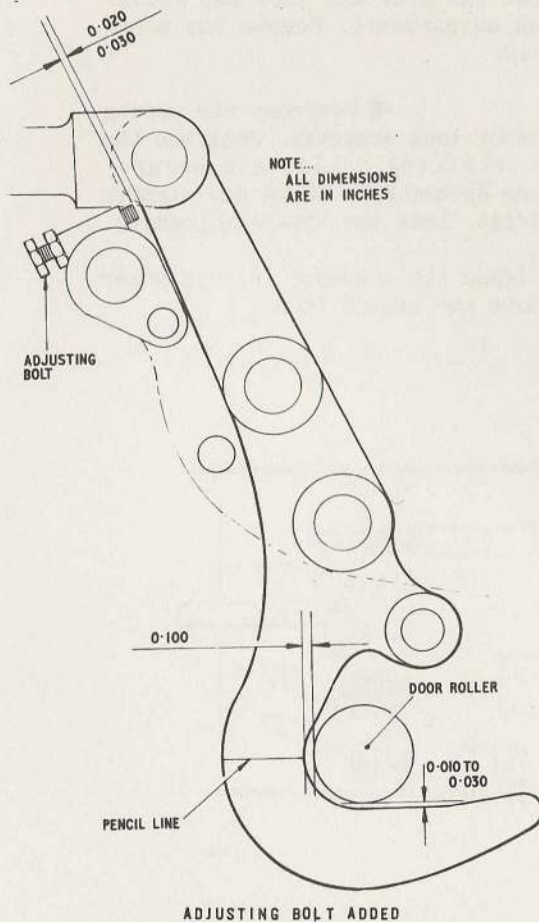

Fig. 7. Wheel-well door latch hook clearances

the slave units, by disconnecting the operating link from the triangular lever at its end remote from the latch unit.

(7) With the latch-unit jack fully extended, measure the distance (it is correct at  $6.60 \pm 0.10$  in.) between the pin centres on the jack. Adjust by altering the eye-end, do not wire-lock the lock jack, fork end or clevis pin.

(8) Adjust the three door rollers so that the top of each roller is at its maximum distance above the door skin.

(9) Using the hand pump, raise the door until the striker pin, on the forward roller-bracket, is in line with the trigger on the master latch. Check that the gap between the two components is 0.040 in. by inserting a feeler gauge between the door and main plane. Adjust the gap as required by altering the trigger setting with the two adjusting bolts (fig.3).

(10) Adjust the door roller to produce the 0.010 to 0.030 in. clearance (fig. 7) as follows:-

(a) Ensure that the door stop bolts are correctly adjusted (para.22).

(b) Close the door and apply maximum hydraulic pressure with the hand pump.

(c) Release the pressure and allow the door roller to fall on to the latch hook. The roller is correctly adjusted when the leading edge of the door is flush with the main-plane skin.

(d) If adjustment is necessary slacken the pinch bolt in the roller bracket and rotate the eccentric adjustment with a screwdriver. Continue adjustment by

trial and error until the correct roller setting is obtained.

(e) Lock the roller adjustment.

(11) Adjust the latch-hook adjusting bolt (fig.7) to produce the 0.10 in. clearance as follows:-

(a) Scribe a pencil line across the face of the hook (fig.7).

(b) Measure the length of the line with calipers and note the dimension.

(c) Line the inside radius near the pencil line with Plasticine and operate the hand pump to close the door.

(d) Open the door and measure along the line again, this time including the depth of Plasticine which has not extruded. The dimension is correct if it exceeds that noted in (b) by 0.10 in.

(e) If adjustment is required, screw the adjusting bolt in or out until the correct dimension is obtained. One turn of the bolt gives approximately 0.018 in. movement at the latch hook.

(f) After adjusting, remove all traces of Plasticine.

(g) Open the door fully and manually operate the latch mechanism so that the door hook sits on the mechanical latch stops.

(h) Remove the threaded pivot pin from the clevis end and push the jack ram fully home; adjust the jack ram until the fork end and hook are aligned before replacing the pivot pin. Lock the jack, fork end and pivot pin.

**CAUTION**

Ensure that the pivot pin is not overtightened as this would cause the fork to lock on the latch hook.

(j) Set the adjusting bolt at the top of the door hook (fig.7) to obtain a clearance of 0.02 to 0.03 in. between the bolt and the hook.

(k) Close the door and check that clearances obtained in operation (10) and (11)(a) to (e) are correct. Lock the adjusting bolt.

(l) Open and close the door several times to check that the locks are functioning smoothly.

(12) Connect the operating link to the slave latches with the connecting bolt, but do not fit the nut.

(13) Fit the setting tools to the plain latch and the microswitch latch support channels (fig.8). The tools should be as close as possible to the line of movement of the hooks, without obstructing their movement, and may require packing to achieve this. The bolts in the tools must be tightened such that the tool setting may be altered by firm thumb pressure.

(14) Adjust the door roller for the plain latch as follows:-

(a) Close the door and apply maximum hydraulic pressure with the hand pump.

(b) Open the door fully and close all the latch units by breaking the main unit toggle lock using a suitable tool.

(c) Insert the setting pin between the plain hook and the setting tool, which now indicates the door

roller setting. The door roller is correctly positioned when the pin is a sliding fit. If adjustment is required, proceed as described in (9) (d).

(15) Check the 0.10 in. gap by the method described in (10). The gap is adjusted by varying the length of the link from the master latch unit. After adjustment, secure and lock the bolt which was temporarily fitted in (11).

(16) Tighten and lock the door roller pinch bolt.

(17) Operate the microswitch operating mechanism, in the remaining latch unit, to move the indicator to position 2 engraved on the keep plate (fig.4). Restrain the indicator in this position by inserting a narrow, sheet-metal distance piece into its slot.

(18) Set the door roller for the micro-

switch latch unit by repeating the procedure described in (13).

(19) Set the latch hook by repeating the procedure described in (14). Adjust the link to the plain latch to correct setting. Remove the distance piece from the indicator.

(20) Refer to para.26 and adjust the microswitch operating linkage.

(21) Open the door and lock the roller and link adjustments. Remove the setting tools.

(22) ◀ Compress the spring of the door-lock assembly. Position the spring retaining collar and secure, using new spokes EEAS.38/2A and nipples EEAS.37/14A. Lock the spokes by peening.

(23) Release the sequence valve plunger and remove the ground locks.

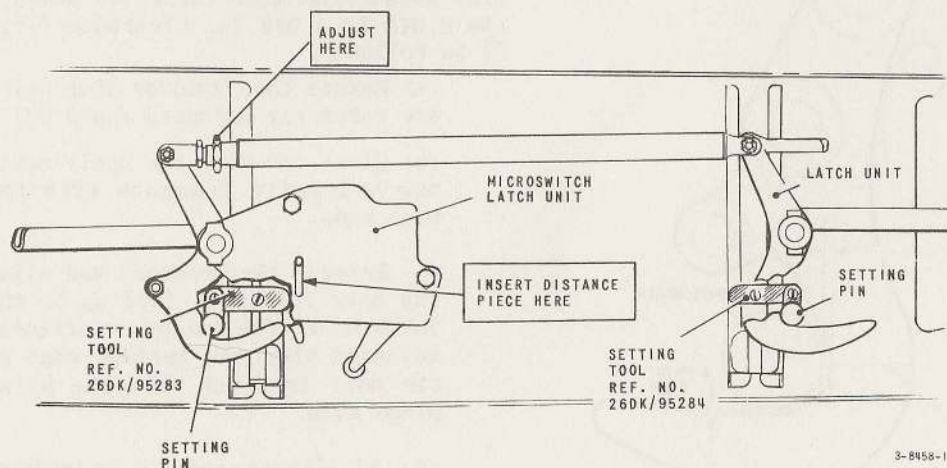
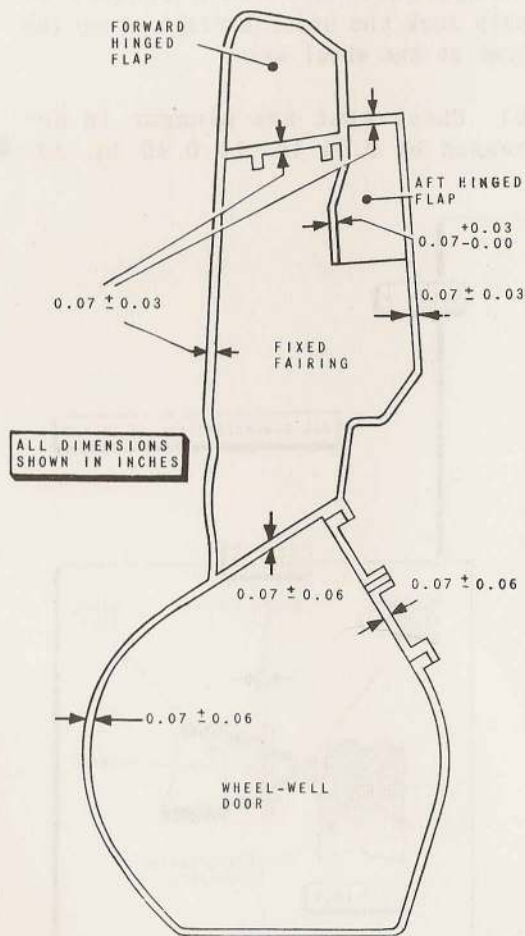

Fig.8. Wheel-well door latch adjustment

(24) Retract the undercarriage with the hand pump and check for correct functioning, and minimum clearances (para.29 and 30).

(25) Carry out a functioning test (Chap.6).



NOTE...  
HYDRAULIC SYSTEM TO BE PRESSURIZED TO 3000 LB/IN<sup>2</sup> WHEN CHECKING CLEARANCES

3-8459-1

Fig.9. Wheel-well door and fairing clearances

**Adjusting the main undercarriage door-jack override**

24.  
(1) Jack and trestle the aircraft (Sect.2, Chap.4) leaving the ground locks in position.

(2) Connect a ground servicing trolley to services No.1 hydraulic ground test connections.

(3) Connect a ground d.c. electrical supply.

(4) Remove the latch striking pin and adjacent door roller, (note the position of the door roller washers) by removing the associated split pins, nuts and washers through the access hole provided. Clamp the door jack sequence valve.

(5) Remove the connecting pin from the jack eye-end and insert the setting pin.

(6) Select alighting gear UP and, using the hand pump, close the door until the jack is fully bottomed.

(7) Check the door-droop (it is correct at 0.15 in.) at the point directly opposite the jack. Adjust by altering the ram eye-end.

(8) Open the door and remove the setting pin. Reconnect the door to the jack using the standard pin. Refit the latch striking pin and door roller by the reversal of (4) and reset the roller clearance (para.23). With the system pressurized to 3000 lb/in<sup>2</sup> ensure that the mechanical lock indicator on the underside of the jack is indicating full engagement (Chap.6).

(9) Fully close and open the door using the hand pump, checking for correct operation and minimum clearances (para.29 and 30).

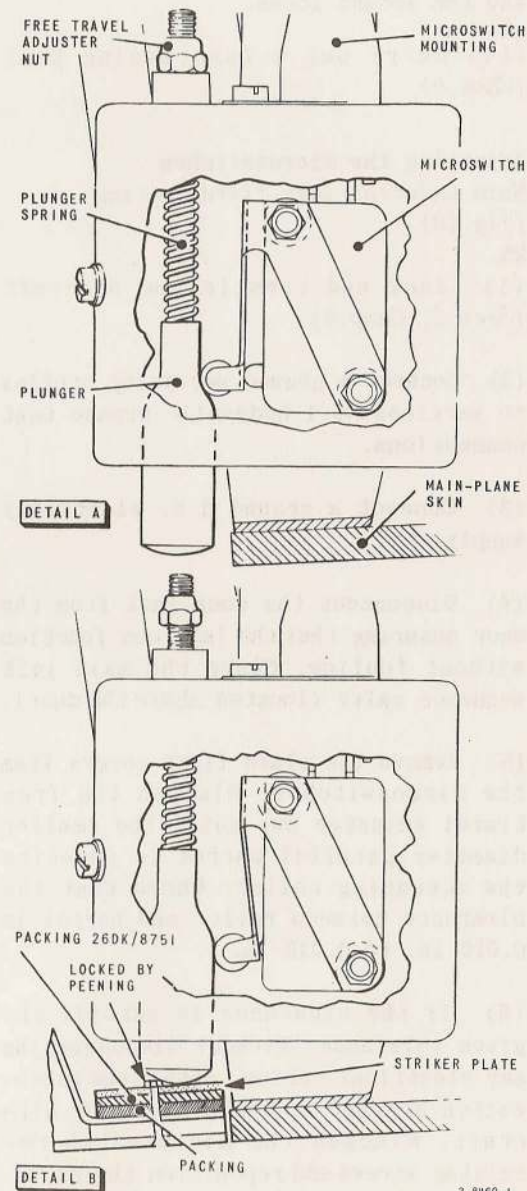

Fig.10. Main undercarriage fixed-fairing microswitch settings

(10) Remove the sequence valve clamp and the ground locks.

(11) Carry out a functioning test (Chap.6).

**Adjusting the microswitches**

*Main undercarriage fixed-fairing*  
(fig.10)

25.

(1) Jack and trestle the aircraft (Sect.2, Chap.4).

(2) Connect a ground servicing trolley to services No.1 hydraulic ground test connections.

(3) Connect a ground d.c. electrical supply.

(4) Disconnect the door jack from the door ensuring that the jack can function without fouling. Clamp the main jack sequence valve (located above the door).

(5) Remove the glass fibre covers from the microswitches. Slacken the free travel adjuster nut until the smaller diameter parallel barrel is opposite the actuating roller. Check that the clearance between roller and barrel is 0.010 in. to 0.015 in.

(6) If the clearance is outside the given tolerance. Without disconnecting any electrical cables, detach the microswitch bracket assembly from the aircraft. Slacken the microswitch retaining screws and reposition the microswitch to obtain the correct clearance. Tighten the microswitch retaining screws and check that the clearance is

still within tolerance. Lock the attachment nuts with Loc-Tite Ref.No.33H/2202572. Refit the microswitch bracket assembly to the aircraft.

(7) Tighten the free travel adjuster nut until the actuating roller just contacts the tapered neck of the plunger. Refit the glass fibre cover. Depress the spring-loaded plunger and ensure that the microswitch operates before the plunger has travelled 0.10 in. If

the microswitch does not operate within this limit it must be changed.

(8) Retract the undercarriage using the aircraft hand pump, then apply full system pressure of 3000 lb/in<sup>2</sup> through the hydraulic servicing trolley to fully lock the undercarriage. Prop the strut at the wheel axle.

(9) Check that the plunger is depressed by 0.35 in. to 0.40 in. Ad- ▶

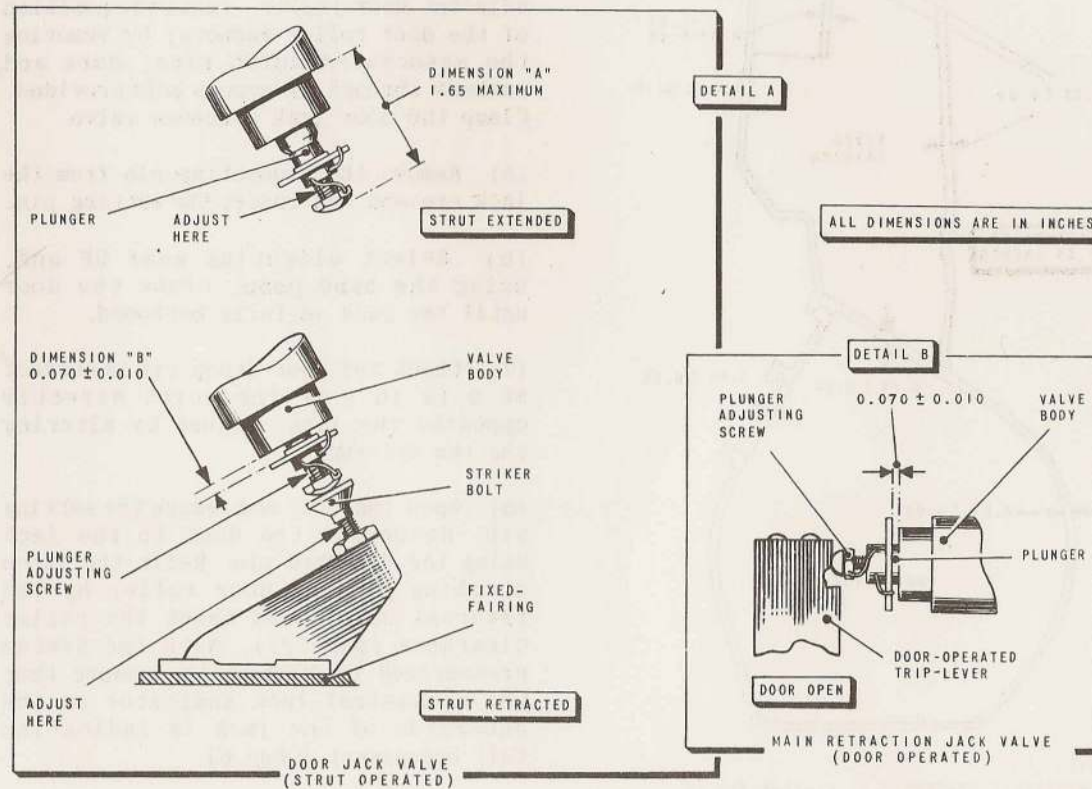

3-8461-1

Fig.11. Adjusting the main undercarriage sequence valves

justment is by raising or lowering the steel striker plate using the special-to-type packings Ref.No.26DK/8751 to suit (*fig.10, detail B*).

(10) Remove the prop and fully extend the undercarriage.

(11) Connect the door jack to the door. Remove the clamp from the sequence valve.

(12) Carry out a functioning test (*Chap.6*).

*Main undercarriage latch unit (fig.4)*

26.

(1) Jack and trestle the aircraft (*Sect.2, Chap.4*). Leave the ground locks in position.

(2) Connect a ground servicing trolley to services No.1 hydraulic ground test connections.

(3) Connect a ground d.c. electrical supply.

(4) Clamp the door jack sequence valve.

(5) Ensure that the door roller and latch hook are set correctly (*para.23 (18) and (19)*). This satisfies operation 1 of the instructions engraved on the labels fixed to the unit.

(6) ▶ ◀ Release the spring

pressure from the door-lock assembly (para.23(5)).

(7) Disconnect the link from the latch hook, ensuring that the link can function without fouling. Secure the hook in the fully open position.

(8) With alighting gear selected UP, close the door and pressurize the hydraulic system to 3000 lb/in<sup>2</sup>. Check that the indicator guide pin has moved to position 1 (door shut but unlocked). If this is not so, adjust by raising or lowering the striker block to suit. This satisfies operation 2 of the instructions.

(9) Select alighting gear DOWN and open the door. Reconnect the link to the hook.

(10) ◀ Reset the door-lock assembly spring (para.23(22)).

(11) With alighting gear selected UP, close the door and pressurize the system to 3000 lb/in<sup>2</sup>. Check that the indicator guide pin has moved to position 2 (door shut and locked). If this is not so, adjust by altering the lever-assembly adjusting nut. This satisfies operation 3 of the instructions.

**Note...**

The instructions given on the latch unit labels are for reference only and read as follows:-

1. Adjust hook to door roller as shown on EB2.40.9.

2. With door latch hook disengaged adjust bracket on U/C door, so that movement of lever pivoted at A causes

guide pin to move up to line across the slot marked 1.

3. With 1 and 2 completed, engage the latch so that with door closed and latch hook home the guide pin has moved up its slot to point marked 2.

(12) Select alighting gear DOWN and unlock the door using the hand pump. As the latch hook commences to disengage observe the indicator guide pin and check that the microswitch trips when the guide pin is  $0.125 \pm 0.010$  in. below position 2. If this is not so, proceed as follows:-

(a) Mark the position of the guide pin as the microswitch just trips.

(b) Adjust by altering the lever assembly adjusting nut until, with the door shut and locked and the

system pressurized to 3000 lb/in<sup>2</sup>, the guide pin is  $0.125 \pm 0.010$  in. above the switch tripped mark.

(13) Fully extend the undercarriage. Remove the clamp from the sequence valve.

(14) Fully retract and extend the undercarriage using the hand pump, checking for correct functioning.

(15) Carry out a functioning test (Chap.6).

*Main undercarriage radius rod*

27. For details refer to Table 2.

*Nose undercarriage*

28. For details refer to Table 2.

**Wheel-well door and fairing clearances (fig.9)**

29. Following a breakdown or alteration of the wheel-well door or fairings, it is essential that the clearances shown in the illustration are maintained, and that a minimum clearance of 0.050 in. is maintained at all points between the fairings and the structure during retraction and extension.

**Main undercarriage clearances**

30. Following a breakdown or alteration of the main undercarriage or its associated components, it is essential that a minimum clearance of 0.060 in. is maintained between all moving parts and the structure, except between the jack attachment lugs on the strut and the strut pivot bracket (para.3), where a

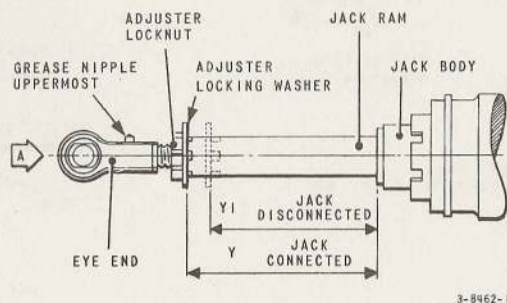

Fig.12. Main retraction jack override

RESTRICTED

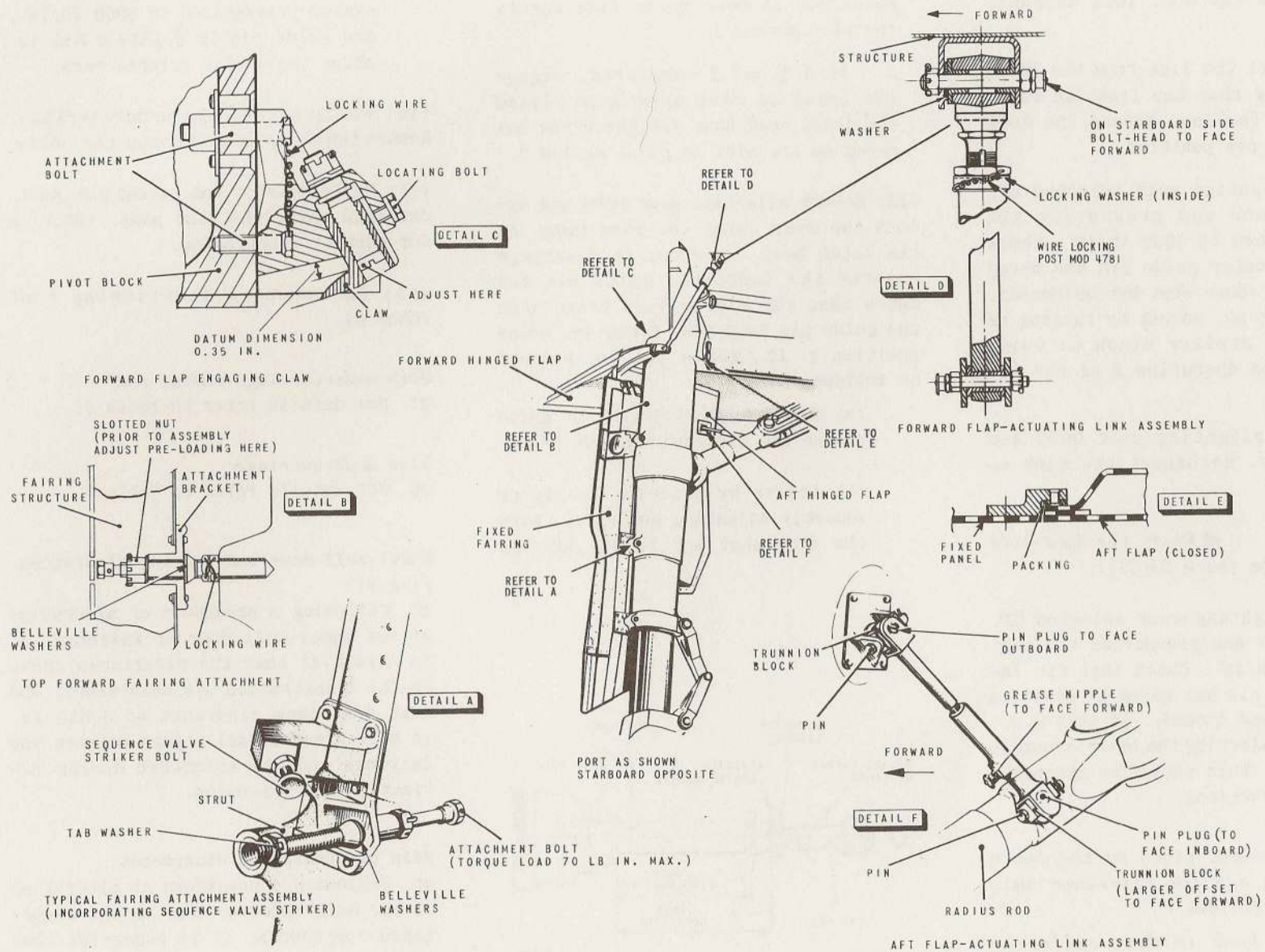

FIG.13. SHOCK - ABSORBER FAIRING - REMOVAL AND ASSEMBLY

MOD.4781 EMBODIED

RESTRICTED

UK RESTRICTED

DETAIL A

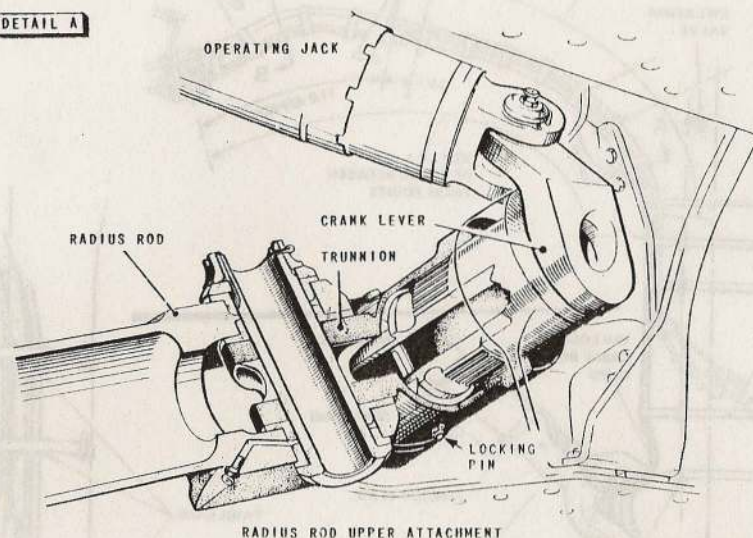
TRUNNION  
BLOCK

TRUNNION PIN

LOCKING PIN

FAIRING ATTACHMENT  
BRACKET

RADIUS ROD LOWER ATTACHMENT

DETAIL B

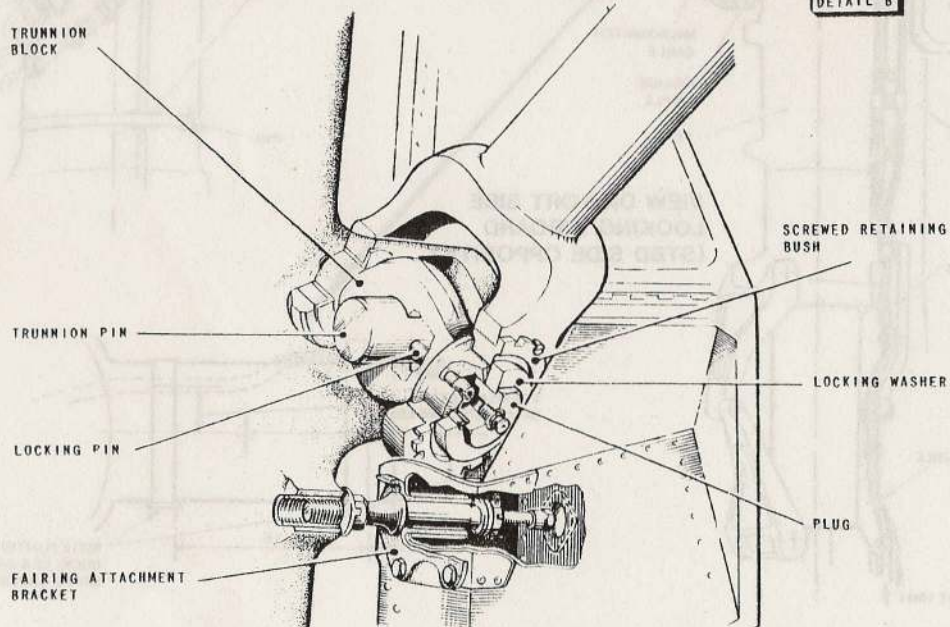

3-8968-1

Fig. 14. Radius rod - removal and assembly

minimum clearance of 0.030 in. is permissible.

Adjusting the main undercarriage  
sequence valves (fig. 11)  
Main retraction jack (detail B)

31.

(1) Jack and trestle the aircraft  
(Sect. 2, Chap. 4).

(2) Connect a ground servicing trolley  
to services No. 1 hydraulic ground test  
connections.

(3) Connect a ground d.c. electrical  
supply.

(4) With alighting gear selected DOWN  
pressurize the hydraulic system to 3000  
lb/in<sup>2</sup>.

(5) With hand pressure applied to the  
door, in a direction to close it, use  
Plasticine to measure the clearance (it  
is correct at  $0.070 \pm 0.010$  in.) between  
the washer on the valve plunger and the  
end face of the valve body. Adjustment  
is by altering the plunger adjusting  
screw.

(6) Fully retract and extend the under-  
carriage checking for correct sequencing.

(7) Carry out a functioning test  
(Chap. 6).

Main door jack (detail A)

32.

(1) Jack and trestle the aircraft  
(Sect. 2, Chap. 4).

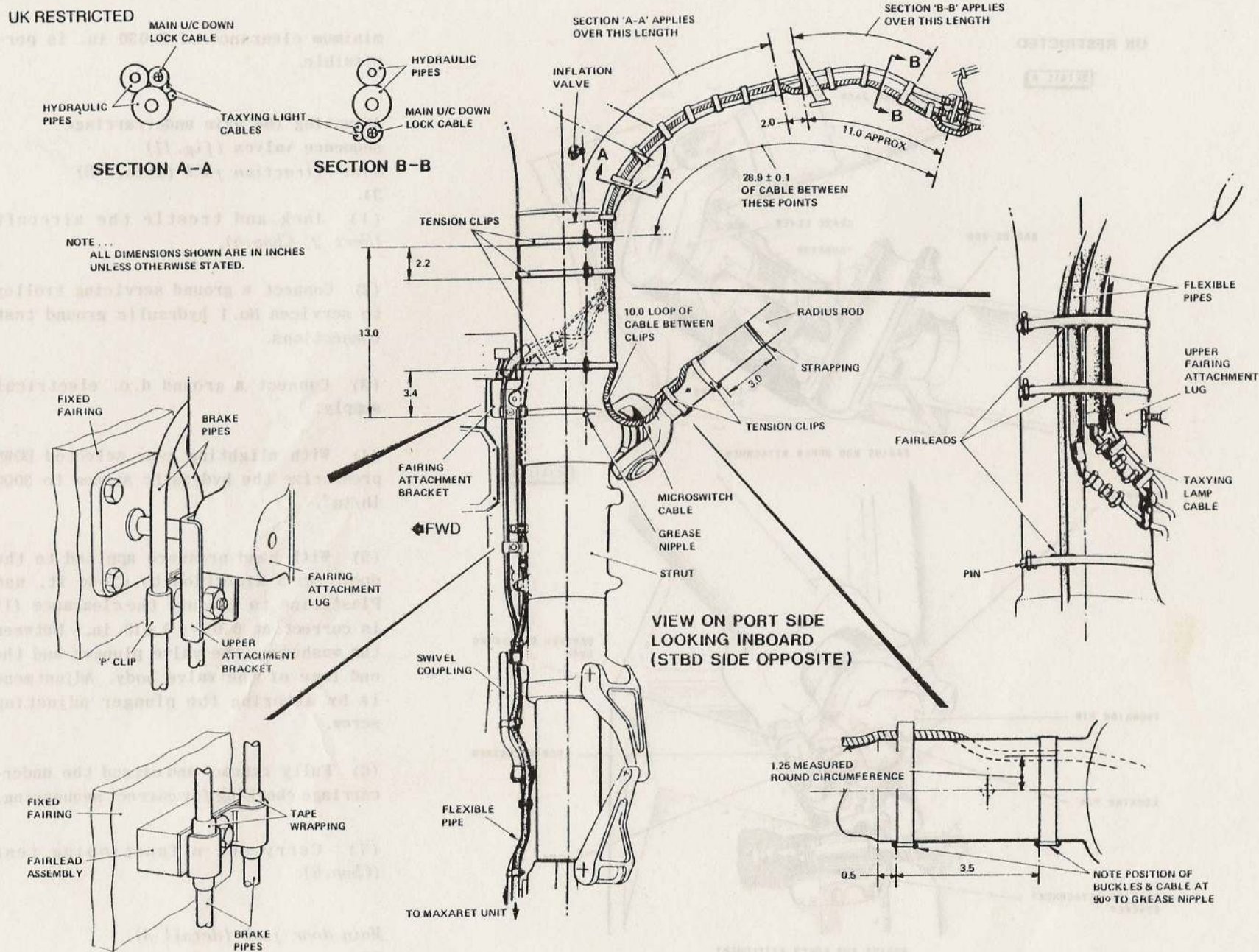

FIG.15 STRUT AND RADIUS ROD - PIPING AND CLIPPING DETAILS

◀ STI/LIGHTNING/528C INCORPORATED ▶

(2) Connect a ground servicing trolley to services No.1 hydraulic ground test connections.

(3) Connect a ground d.c. electrical supply.

(4) Disconnect the door jack from the door ensuring that the jack can function without fouling. Clamp the main jack sequence valve.

(5) With the undercarriage fully extended and the system pressurized to 3000 lb/in<sup>2</sup>, measure the clearance between the head of the plunger adjusting screw and the shoulder on the valve body. It must not exceed 1.65 in. (dimension 'A'). Adjustment is by altering the plunger adjusting screw.

(6) Fully retract the undercarriage and prop the strut at the wheel axle.

(7) With the system pressurized to 3000 lb/in<sup>2</sup>, use plasticine to measure the clearance between the washer on the valve plunger and the end face of the valve body. It is correct at  $0.070 \pm 0.010$  in. (dimension 'B'). Adjust by altering the striker bolt on the fixed fairing.

(8) Remove the prop and fully extend the undercarriage.

(9) Connect the door jack to the door. Remove the clamp from the sequence valve.

(10) Fully retract and extend the undercarriage checking for correct sequencing.

(11) Carry out a functioning test (Chap.6).

#### Wheel-well door - manual release

##### Note...

*Personnel must exercise extreme caution during the operation, as the undercarriage strut will be released by the door contacting the sequence valve during the last few degrees of movement.*

33. If during ground servicing either wheel-well door fails to open, the locking mechanism can be manually released as follows:-

(1) Ensure that the alighting gear is selected UP.

(2) Switch off any connected hydraulic servicing trolleys.

(3) Remove the small access panel from the undersurface of the main plane, located immediately below the micro-switch latch unit on the affected side (fig.4).

(4) Exhaust the hydraulic pressure by operating the wheel brake lever.

(5) With alighting gear selected DOWN, insert a long screwdriver through the panel aperture, and, with firm pressure, push the latch-hook release stud (fig.4) upwards until the door is unlocked; the door can then be pulled open.

#### REMOVAL AND ASSEMBLY

##### Note...

*When connecting hydraulic fluid pipes the unions must be tightened to the correct torque loading (Chap.6).*

##### Tools and equipment

34. For tools and equipment used in the following operations, refer to Table 1.

#### MAIN UNDERCARRIAGE

##### Wheel

##### Removal

##### 35.

(1) Jack the main wheel (Sect.2, Chap.4).

(2) Apply the parking brake with the rudder pedals in neutral.

(3) Remove the split pins locking the axle nut, and unscrew the nut, using peg spanner Ref.No.26DK/95082. Remove the washer.

(4) Withdraw the wheel from the axle, using extractor Ref.No.26DK/95708.

##### Assembly

##### 36.

(1) Unless the brake plates are aligned ready to receive the wheel, align them with fixture Ref.No.27G/6804; this can only be done with the brakes released. After alignment, apply the brakes before removing the fixture.

##### Note...

*Prior to fitting the wheel:-*

(1) Ensure that the torque-unit locking plate, incorporated on the

RESTRICTED

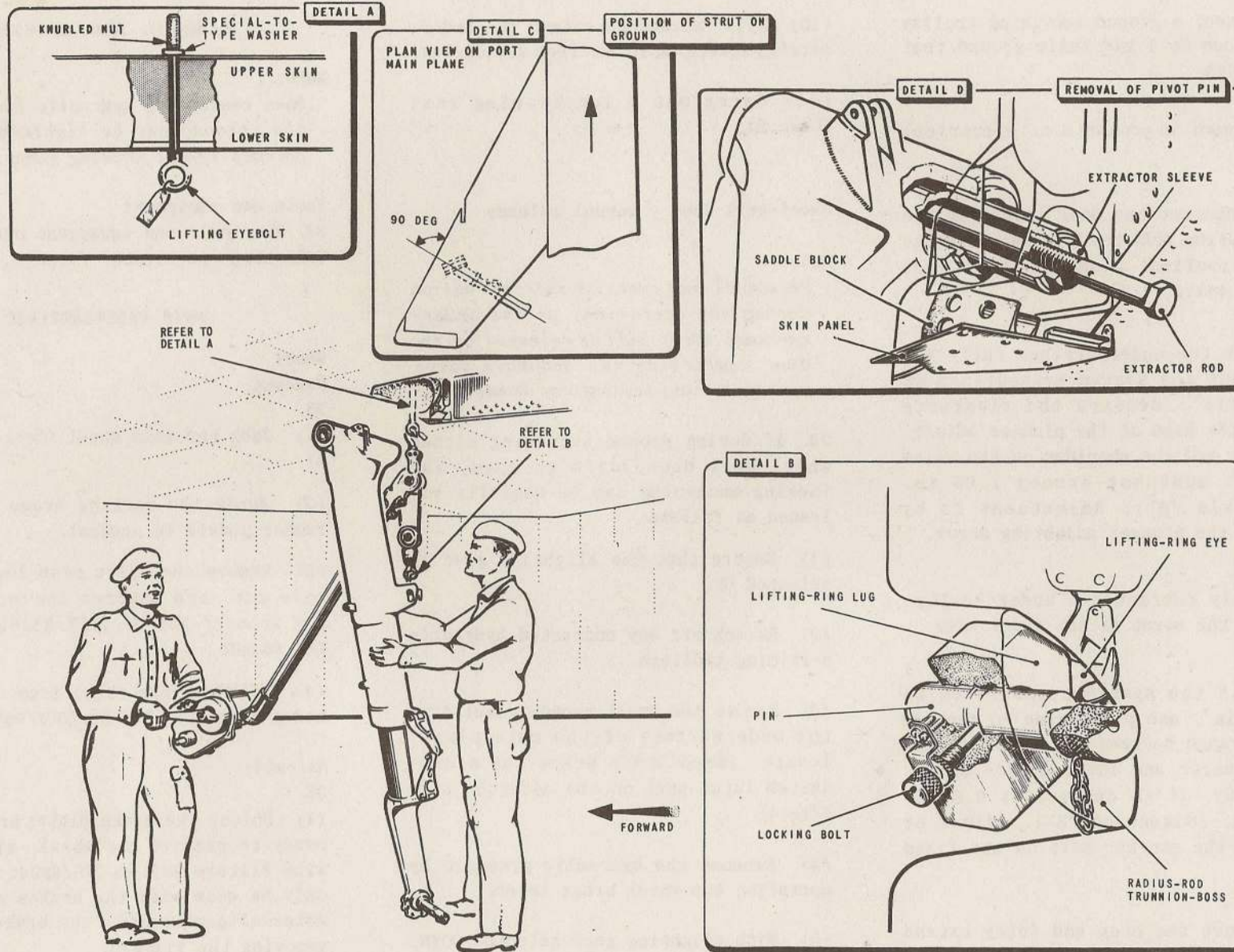

FIG. 16. MAIN UNDERCARRIAGE STRUT - REMOVAL AND ASSEMBLY

◀DETAIL AMENDMENT▶

RESTRICTED

brake unit, is correctly located and locked. Refer to A.P.2337, Vol.1, Book 2, Sect.3, Chap.4.

(2) Ensure that the sleeve, which is a sliding fit on the axle, is correctly positioned.

(2) Offer up the wheel to the axle and align the tenon sleeves on the periphery of the brake housing with the brake plate tenons. Push the wheel fully on to the axle and release the brakes.

(3) Fit the washer and the axle nut, then adjust the nut to give the wheel an end float of 0.005 to 0.010 in. To assist this operation the nut has six slots set at 60 deg and the axle has two pairs of diametrically-opposed holes at 90 deg to each other. Adjust by following the appropriate method described below:-

(a) If two slots are aligned with a pair of holes initially, unscrew the nut until the next pair of slots coincide with the same holes.

(b) If no holes and slots are aligned initially, unscrew the nut by the minimum amount necessary to achieve this. Then unscrew the nut further to bring the first available pair of slots in line with the other pair of holes, i.e. half a pitch between slots.

#### Note...

Restrain the washer from rotating whilst altering the axle nut.

(4) Lock the nut with two new split pins.

(5) Check the wheel for freedom of rotation, allowing for the retarding effect of the Maxaret unit.

(6) Examine the flat on the Maxaret unit rotor where it contacts the wheel and ensure that it conforms to the correct dimension of 0.75 in.  $\pm_{0.0}^{0.25}$  in. If necessary, adjust the shimming beneath the Maxaret unit flange.

#### Brake unit

##### Removal

#### 37.

(1) Remove the main wheel (para.35).

(2) Ensure that the brakes are released, and then disconnect the hydraulic fluid pipe from the Maxaret unit to the brake unit at the banjo connection.

(3) Remove the split pins and nuts securing the six brake unit attachment bolts, and withdraw the brake unit over the axle.

#### Assembly

#### 38.

(1) If a new brake unit is being fitted, remove the identification label from the unit prior to assembly and coat the threads of the six brake unit attachment bolts with grease ZX-13.

(2) Offer up the unit to the shock-absorber strut and insert the attachment bolts through the holes in the strut. Fit the nuts and tighten to a torque loading of 55 lb ft; if necessary increase the loading to align the appropriate slot with the split pin hole. Fit and lock the split pins.

(3) Lubricate the banjo bolt using hydraulic system fluid and connect the hydraulic fluid pipe from the Maxaret unit to the brake unit. Tighten the banjo bolt to a torque loading of 8 lb ft and wire-lock.

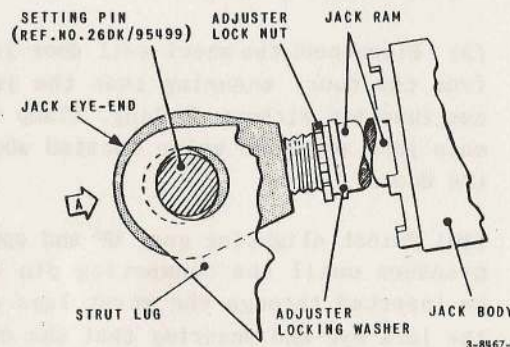

Fig.17. Nose retraction jack override

(4) Bleed the wheel brakes hydraulic circuit and, after assembly of the wheel, carry out wheel-brake functioning tests (Chap.6) and wire-lock the bleed screws.

#### Retraction jack

##### Removal

#### 39.

(1) Jack and trestle the aircraft (Sect.2, Chap.4).

(2) Connect a ground servicing trolley

RESTRICTED

to services No.1 hydraulic ground test connections.

(3) Connect a ground d.c. electrical supply.

(4) Select alighting gear UP, and operate the hand pump to disengage the radius-rod locks.

(5) Disconnect the hydraulic fluid hoses at the jack and blank the connections.

(6) Slacken the locknut of the jack ram adjuster.

(7) Remove the split pin and nut and withdraw the connecting pin from the jack ram eye-end. Raise the jack and rotate the eye-end through 90 deg.

(8) Remove the circlip and the remaining attachment pin.

(9) Withdraw the jack by pushing it inboard and lowering it, body first. The shock-absorber strut may be moved manually to facilitate this operation.

Assembly

40.

(1) Prepare the jack (Chap.6).

(2) If a replacement jack is being fitted, transfer the shuttle valve from the unserviceable unit.

(3) Slacken the adjuster locknut, move the adjuster locking washer clear of the ram castellations and adjust the eye-end so that 11 threads are exposed

and the grease nipple is uppermost. Reposition the adjuster locking washer and tighten the adjuster locknut.

(4) Offer up the jack, shuttle valve forward, and attach the body end to the cranked lever (fig.14) using the connecting pin and circlip. Support the jack body but do not connect it to the strut.

(5) Bleed the hydraulic fluid pipes (Chap.6) and connect them to the jack.

(6) Connect a ground d.c. electrical supply.

(7) Select alighting gear DOWN and manually push the strut to the fully down position, ensuring that the down-lock engages. Insert the ground lock (Sect.2, Chap.1) through the radius rod.

(8) Apply a pressure of 3000 lb/in<sup>2</sup> with the hand pump to fully retract the jack and measure the distance (fig.12, dim.Y1) between the jack body and the adjuster locking washer.

(9) Disconnect the wheel-well door jack from the door, ensuring that the jack can function without fouling. Clamp the main jack sequence valve located above the door.

(10) Select alighting gear UP and apply pressure until the connecting pin can be inserted through the strut lugs and the jack eye-end ensuring that the connecting pin head faces outboard (fig.1, detail B). Fit and lock the castellated nut using a new split pin.

(11) Select alighting gear DOWN, apply a pressure of 3000 lb/in<sup>2</sup>, with the hand pump and again measure the distance (fig.12, dim.Y) between the jack body and the adjuster locking washer.

(12) Subtract dimension Y1 from Y; Y - Y1 should be 0.050 ± 0.010 in. If it is not, adjust as follows:-

(a) Remove the ground lock and release all hydraulic pressure from the jack by successively selecting UP and DOWN.

(b) Slacken the adjuster locknut and move the adjuster locking washer clear of the ram castellations.

Note...

One complete turn of the jack ram = 0.050 in. approx.

(c) If dimension Y - Y1 is less than 0.040 in. the jack ram requires shortening. This is achieved by turning the jack ram, using a C spanner, counter-clockwise looking on the ram in the direction of arrow A (fig.12), for the required amount. Line up the jack castellations with the adjuster locking washer and tighten the adjuster locknut.

(d) If dimension Y - Y1 is greater than 0.060 in. the jack ram requires lengthening. This is achieved as in (c) except that the jack ram must be turned clockwise.

(e) Select alighting gear DOWN and

apply a pressure of 3000 lb/in<sup>2</sup> with the hand pump and re-check dimension Y as in (11). Repeat adjustment (c) or (d) until dimension Y - Y1 = 0.050 ± 0.010 in.

(13) Wire-lock the adjuster locknut to the adjuster locking washer.

(14) Fully retract and extend the undercarriage with the hand pump, checking for correct clearances (*para. 29 and 30*) and correct functioning.

(15) Connect the door jack to the door. Remove the valve clamp.

(16) Lubricate (*fig. 20*).

(17) Carry out a functioning test (*Chap. 6*).

**Shock-absorber strut fairing** (*fig. 13 and 15*)

**Removal**

**41.**

(1) Disconnect the taxiing lamp cables from the terminal block on the fairing.

(2) Unclip the hydraulic fluid pipes from fairing skin and attachment brackets.

(3) Disconnect the flap actuating links at the flap ends.

**Note...**

*Do not alter the adjustment of the links or difficulty will be experienced when assembling.*

(4) On the seven bolts attaching the

fairing to the strut, slacken the locknuts and unscrew the bolts (accessible through skin panels). Detach the fairing.

**Assembly**

**42.**

(1) Jack and trestle the aircraft (*Sect. 2, Chap. 4*).

(2) Connect a ground servicing trolley to services No. 1 hydraulic ground test connections.

(3) Connect a ground d.c. electrical supply.

(4) Clamp the door-operated main-jack sequence valve.

(5) Disconnect the door jack from the door ensuring the jack can function without fouling.

(6) Remove the aft-flap actuating link. Secure the forward-flap link so that it will not foul during retraction.

(7) Prior to fitting the fairing:-

(a) Apply a torque loading of 20 lb in. to each fairing attachment bolthead. The bolt should just rotate (*refer to fig. 13, detail B for adjustment if necessary*).

**Note...**

*The bolt spindles are lubricated with grease ZX-28 on assembly to the mounting brackets.*

(b) Fit new tabwashers to six of the seven attachment bolts; the

locknuts on the top forward bolt are wire-locked.

(c) If a replacement fairing is being fitted slacken the 2 B.A. mounting bracket attachment bolts and screw in the sequence valve striker.

(8) Offer up the fairing to the strut giving each bolt a thread engagement of approx. 0.125 in.; tighten the bracket attachment bolts. Clip the hydraulic fluid pipes and connect the electrical cables.

(9) Remove the forward flap and its engaging claw from the fairing and the main pivot bracket respectively. Secure the aft flap so that no foul will occur during retraction.

(10) Fully retract the undercarriage using the hand pump and pressurize to 3000 lb/in<sup>2</sup>. Prop the strut at the wheel axle.

(11) Set the fairing close up to the wing until the leading edge is at least 0.030 in. inside the wing contour and the trailing edge is flush with the main-plane skin; at no point must the trailing edge be inside the skin contour. Adjust by altering the fairing attachment bolts, a torque loading of 70 lb in. must not be exceeded.

(12) Check the gaps at the leading and trailing edges of the fairings (*fig. 9*). Adjust by slackening the mounting bracket bolts and displacing the fairing to suit.

RESTRICTED

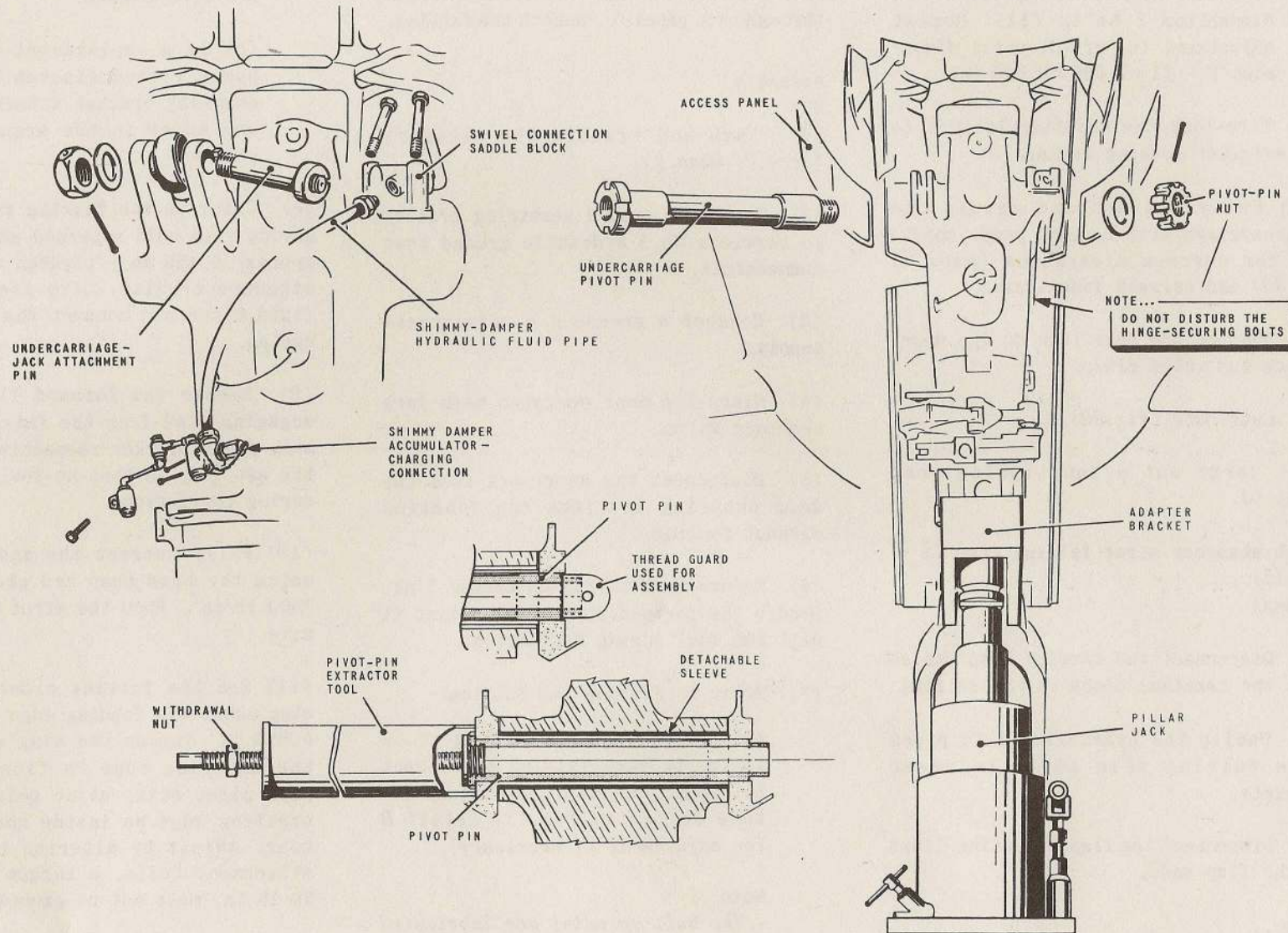

FIG. 18. NOSE UNDERCARRIAGE - REMOVAL AND ASSEMBLY

3-8468-1

RESTRICTED

(13) With the prop removed lower the undercarriage slowly and check that the gaps set in (12) do not decrease as the fairing leaves the aperture and that a minimum clearance of 0.050 in. is maintained at all points during full travel (para.29).

(14) If a replacement fairing is being fitted:-

(a) With the undercarriage fully retracted mark off the fairing to the aperture contour. Before extending the undercarriage lower the fairing clear of the main-plane by unscrewing the fairing attachment bolts; failure to do so will cause a foul.

(b) Trim and adjust the fairing until the gaps are correct (12), and lowering the fairings as for (a) accordingly.

(c) Back off the fairing leading-edge to an angle of 45 deg to the vertical, leaving an edge thickness of approx. 1/16 in. After trimming, original chamfers on the other edges must be maintained.

(d) Carry out operations (10), (11), (12) and (13).

(15) Tighten and lock the attachment bolt locknuts.

(16) Adjust the main door-jack sequence-valve (para.32).

(17) With the undercarriage fully retracted, close the aft hinged flap and check that the correct gaps are maintained at all points (fig.9). Lower the undercarriage and connect the flap actuating link (fig.13, detail F).

(18) Adjust the link until, with the undercarriage fully retracted and pres-

surized to 3000 lb/in<sup>2</sup>, the flap is flush fitting with the fairing and the main pivot access panel at all points. It is permissible to file the packing on the access panel accordingly (detail E). Lower the undercarriage slowly checking that a minimum clearance of 0.050 in. is maintained at all points (para.29).

(19) With the undercarriage fully retracted and pressurized to 3000 lb/in<sup>2</sup> fit the forward hinged flap but do not lock the nuts. Close the flap and check that the correct gap is maintained at all points (fig.9). Before lowering the undercarriage remove the flap; failure to do so will cause a foul between the actuating arm and spar 3.

(20) Lock the nuts on the hinge bolts and connect the flap actuating link (fig.13, detail D). If a replacement fairing is being fitted adjust the link until the distance between the pin centres measures approx. 15.83 in.; failure to do so will cause a foul during initial retraction.

(21) Retract the undercarriage slowly, checking that a minimum clearance of 0.050 in. is maintained (para.29). With the undercarriage fully retracted and pressurized to 3000 lb/in<sup>2</sup>, measure the distance by which the corner of the flap farthest from the hinges must travel to reach a position where the leading edge of the flap will be 0.030 in. inside the main-plane contour.

(22) Partially lower the undercarriage to gain access to the actuating link, and adjust the link as necessary to achieve the 0.030 in. dimension.

(23) Repeat operations (21) and (22) until the flap leading-edge is 0.030 in. minimum inside the main-plane contour

and the trailing-edge is flush with the contour. Check that the correct gaps (fig.9), and the minimum clearance (para.29), have been maintained.

Note...

With the leading-edge correctly positioned a clearance of approx. 0.020 in. will exist between the seating of the flap and the aperture coaming. Coarse adjustment of the link should be avoided, particularly during the final stages of adjustment, to ensure that this clearance is not lost and a foul caused.

(24) Lock the actuating link adjuster, altering the adjustment, if necessary, to engage the tab washer. Wire-lock locknut to screwed adapter (post Mod. 4781, fig.13, detail D).

(25) Lower the undercarriage and refit the flap engaging claw. Adjust the claw to a datum dimension of 0.35 in. (fig.13, detail C). Slowly retract the undercarriage and check that the claw does not foul any part of the flap.

(26) With the undercarriage fully retracted and pressurized to 3000 lb/in<sup>2</sup>, turn the claw adjusting screw clockwise until the claw just touches the flap, then turn counter-clockwise until the claw is eased out of contact with the flap and all strain is removed. The flap should now rattle slightly when hand pressure is applied.

(27) Function the undercarriage slowly, using the hand pump and check that the engaging bracket engages and disengages the claw smoothly.

(28) Adjust the fairing microswitch (para.25).

(29) Function the undercarriage using the hand pump checking for correct functioning and ensuring the correct

RESTRICTED

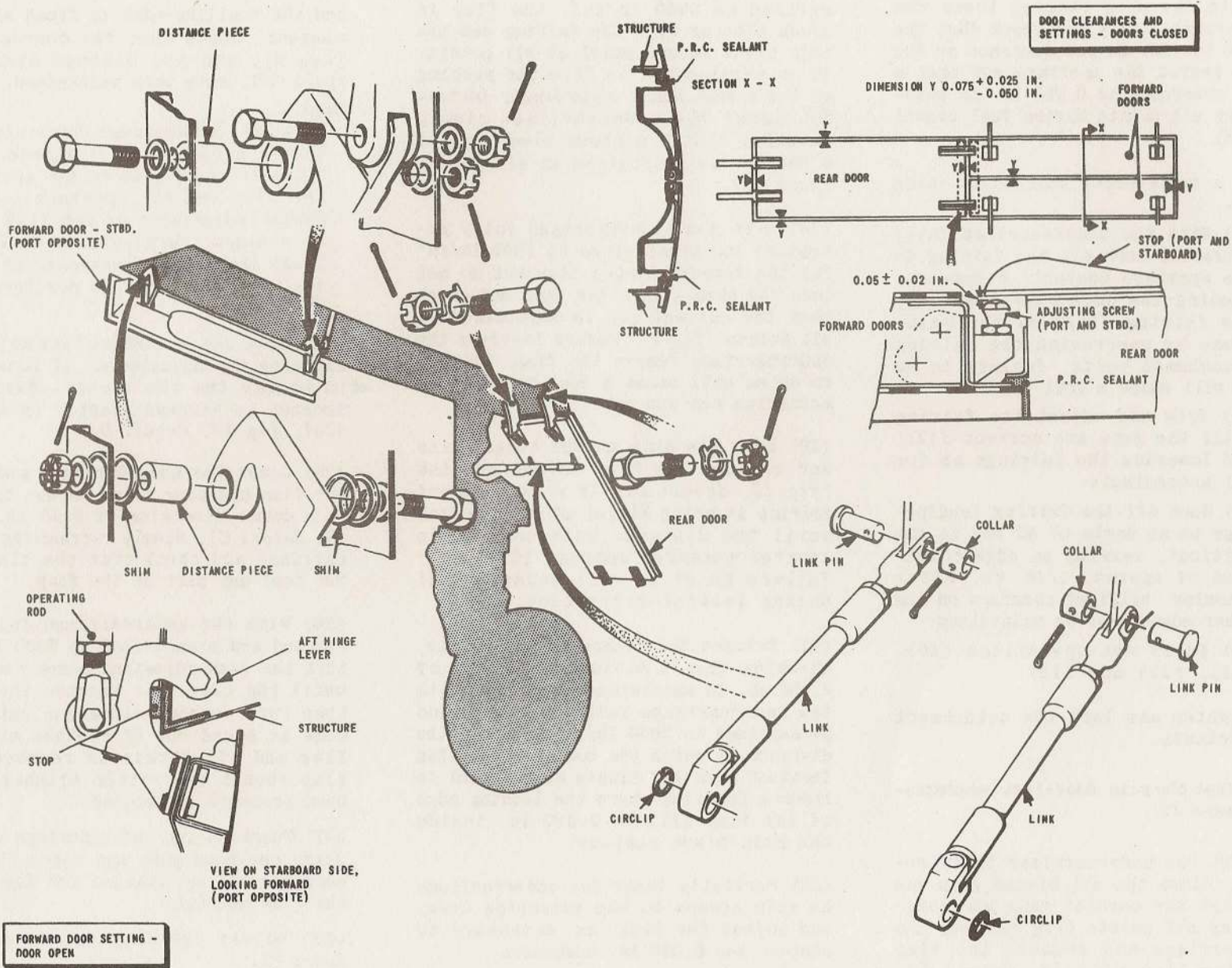

FIG. 19. NOSE UNDERCARRIAGE DOORS — REMOVAL AND ASSEMBLY

3-8469-1

RESTRICTED

clearances are maintained (*para.29 and 30*).

(30) With the undercarriage fully retracted and pressurized to 3000 lb/in<sup>2</sup> close the wheel-well door manually and check that the correct gap between the door and the fairing is maintained (*fig.9*) and the inboard edge of the door is 0.030 in. inside the fairing contour (*para.22*).

(31) Remove the sequence valve clamp. Connect the door jack to the door.

(32) Carry out a taxiing lamp functioning test (*Sect.6, Chap.8*).

(33) Lubricate (*fig.20*).

(34) Fully retract and extend the undercarriage using the hand pump checking for fouls and correct functioning.

(35) Carry out a functioning test (*Chap.6*) ensuring the correct gaps are maintained at all points.

#### Radius rod (*fig.14 and 15*)

##### Removal 43.

(1) Jack and trestle the aircraft (*Sect.2, Chap.4*).

(2) Connect a ground servicing trolley to services No.1 hydraulic ground test connections.

(3) Connect a ground d.c. electrical supply.

(4) Remove the shock-absorber fairing (*para.41*).

(5) Select alighting gear UP and apply hydraulic pressure to release the down lock and to retract the strut a small amount. Place a block under the wheel to prevent the strut from returning to its lowered position.

##### Note...

*If the lock jack is unserviceable, use a lever to disengage the lock plunger in (5).*

(6) Remove the retraction jack (*para.39*).

(7) Remove the ground electrical supply and ensure that the battery switch is off.

(8) Disconnect the flexible hydraulic fluid pipe at the top of the radius rod. Blank the pipe and union.

(9) Disconnect the down-lock micro-switch cable from the terminal blocks on spar 4.

(10) Unstrap the microswitch cable from the hydraulic fluid pipes, and slacken the clips around the undercarriage strut sufficiently to permit withdrawal of the cable.

(11) Detach the radius rod from the strut in the following sequence (*fig.14, detail B*):-

(a) Unscrew the plug and remove the locking washer.

(b) Screw a ¼ in. B.S.F. bolt into the end of the locking pin exposed by removing the plug.

(c) Remove the grease nipple from the aft end of the trunnion pin and substitute a ¼ in. B.S.F. bolt.

(d) Remove the grub screw which locks the screwed retaining bush and slacken the bush.

(e) Withdraw the locking pin and the trunnion.

(f) Remove the retaining bush and withdraw the trunnion block.

(g) Disengage the radius rod from the strut and support it to prevent damage to the main-plane skin.

(12) Unlock and withdraw the locking pin securing the trunnion to the crank lever (*fig.14, detail A*).

(13) Support the weight of the radius rod and withdraw the crank lever from the main-plane bracket.

(14) Remove the radius rod, insert the crank lever through the splined lever on the radius rod, and lock it with the locking pin.

##### Assembly

##### 44.

##### Note...

*If a replacement radius rod is being fitted, transfer the hydraulic fluid pipe and union bracket and the cable clips from the unserviceable unit.*

(1) Remove the locking pin from the splined lever and withdraw the crank lever (*fig.14, detail A*).

RESTRICTED

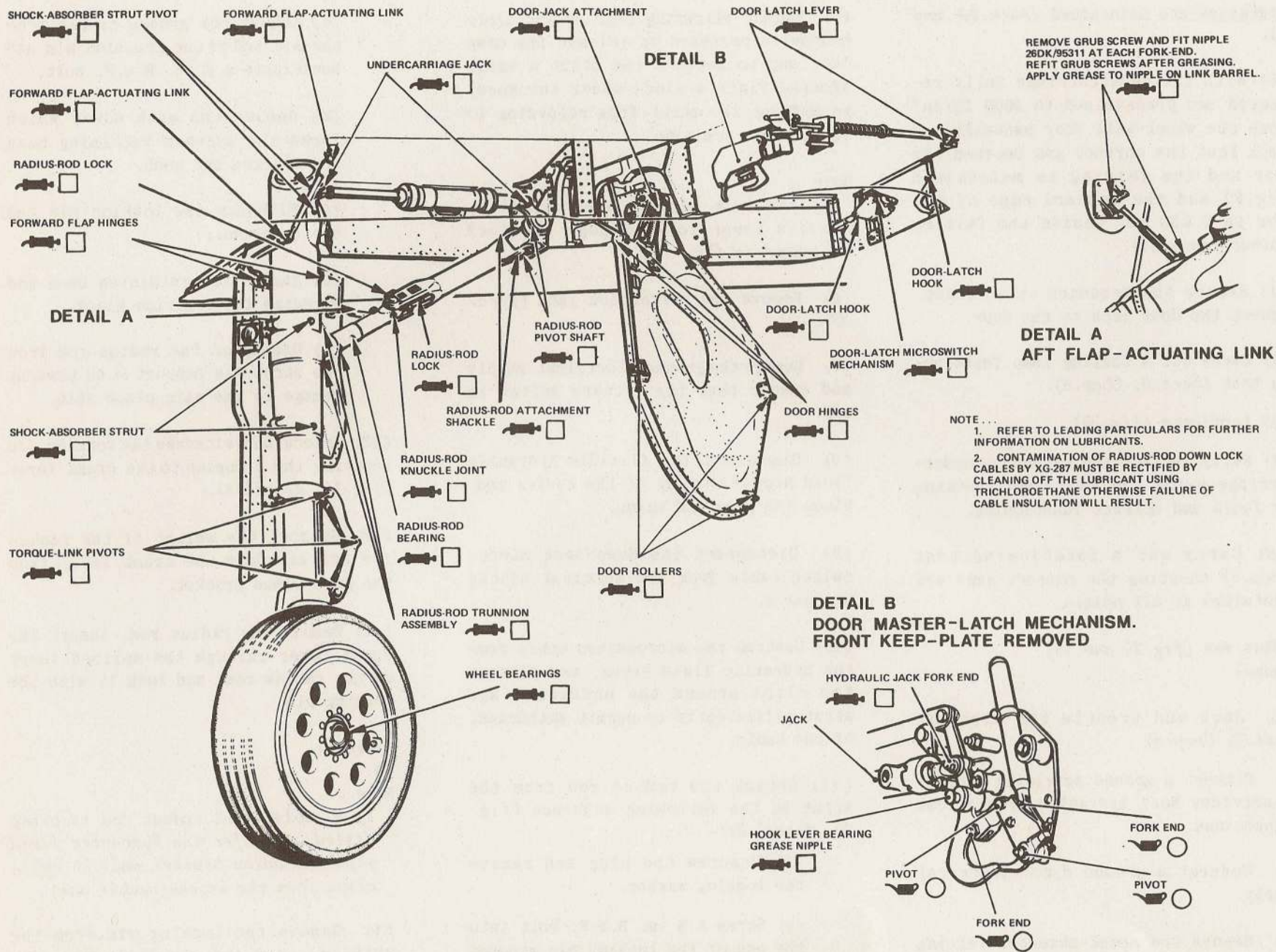

FIG. 20. MAIN UNDERCARRIAGE LUBRICATION POINTS

◀ REDRAWN ▶

RESTRICTED

(2) Smear the crank lever splines with grease XG-287.

(3) With the knuckle joint broken, position the radius rod so that the splined lever is aligned with the wing bracket, and the microswitches face aft.

(4) Noting the position of the master spline, insert the cranked lever through the bracket and the splined lever.

(5) Insert the locking pin and fit a new split pin.

(6) Engage the fork at the lower end with the strut lug and assemble the trunnion joint as follows (*fig.14, detail B*):-

(a) Insert the trunnion block and screw in the retaining bush until it is finger tight.

(b) Insert the trunnion pin with the grease nipple facing aft.

(c) Align the hole in the trunnion pin with the hole in the trunnion block.

(d) Screw a ¼ in. B.S.F. bolt into the locking pin and insert the pin through the trunnion block and trunnion pin. Remove the slave bolt.

(e) Tighten the screwed retaining bush with a C-spanner and fit the grub screw.

(f) Fit the locking washer to the

end of the trunnion block and screw in the plug.

(g) Wire-lock the items together.

(7) Connect the flexible hydraulic fluid pipe to the union at the top of the radius rod.

(8) Pass the microswitch cable through the strut clips and connect it to the terminal block then, with the cables pipes and clips correctly positioned on the radius rod and strut, lock the clips; trap the cables to the flexible pipes.

(9) Fit the retraction jack (*para.40*).

(10) Bleed the lock jack hydraulic fluid pipes (*Chap.6*).

(11) Select alighting gear DOWN and apply pressure to completely lower the strut. Check that the down-lock engages correctly and that the associated red light in the cockpit indicator is extinguished and the green light shows.

(12) Retract the undercarriage with the hand pump and ensure that the down-lock disengages, the cockpit indicator shows a red light, and the correct clearances (*para.29 and 30*) are maintained during retraction.

(13) Lubricate (*fig.20*).

(14) Fit the shock-absorber fairing (*para.42*).

(15) Carry out a functioning test (*Chap.6*).

#### Undercarriage strut

Removal (*fig.13 and 16*)

45.

(1) Jack and trestle the aircraft (*Sect.2, Chap.4*).

(2) Connect a ground servicing trolley to services No.1 hydraulic ground test connections.

(3) Connect a ground d.c. electrical supply.

(4) Remove the shock-absorber fairing (*para.41*).

(5) Release the three clips which secure the flexible hydraulic fluid pipes and the cables to the strut.

(6) Disconnect the flexible pipes from the rigid pipes on the strut.

(7) Remove the brake pressure and return pipes by disconnecting them from the Maxaret unit and detaching the swivel coupling from the strut.

(8) Remove the wheel (*para.35*) and the brake unit (*para.37*).

(9) Refer to *para.43* and carry out (5), (9), (10) and (11). Fold, and support, the radius rod, taking care not to damage the hydraulic pipes or to alter the fairing-flap rod adjustment.

(10) Refer to *para.39* and carry out (6) and (7). Raise the jack clear of the strut leg and support it.

(11) Remove the closing plug and the

RESTRICTED

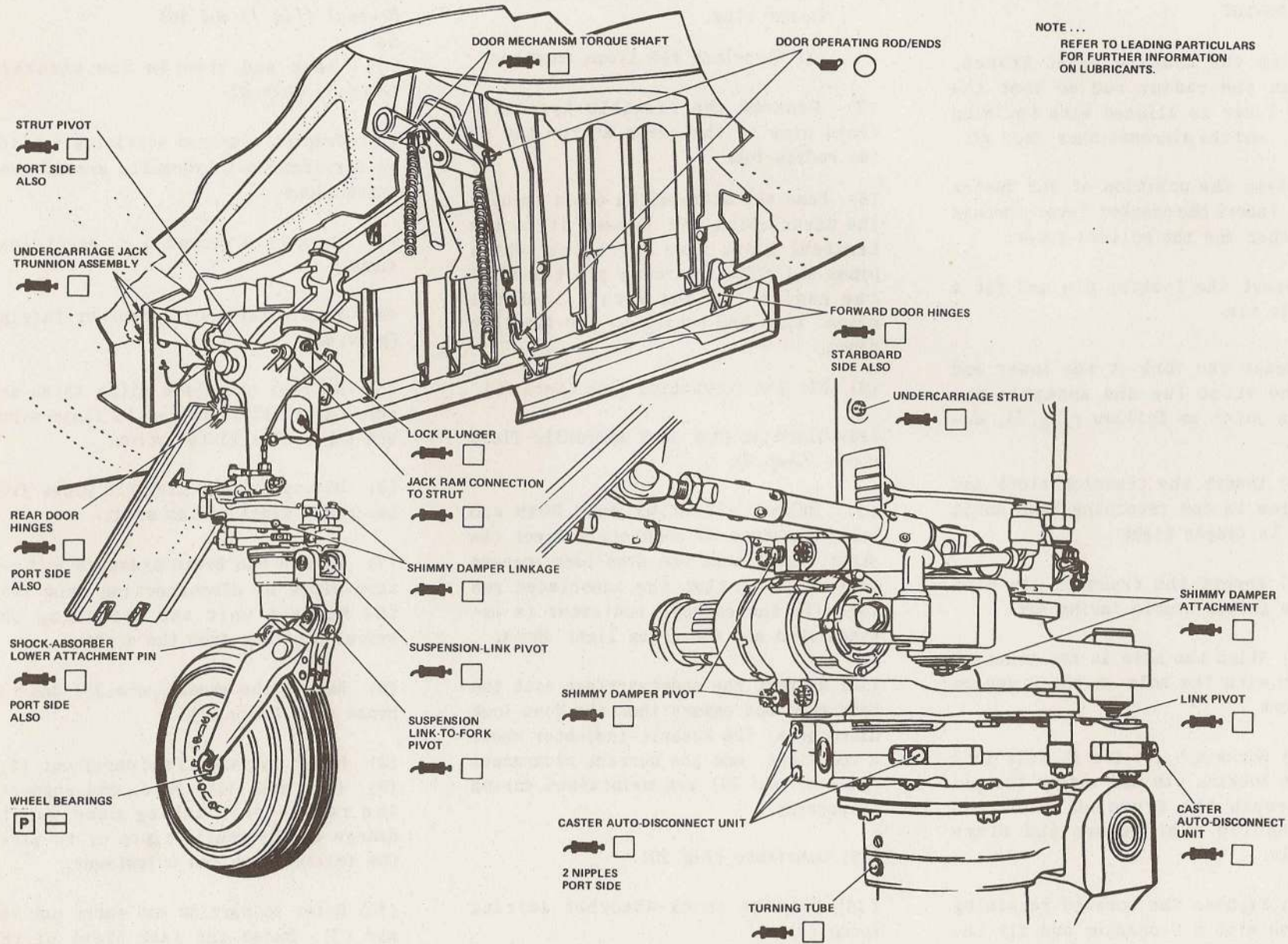

FIG.21. NOSE UNDERCARRIAGE - LUBRICATION POINTS

◀ REDRAWN ▶

RESTRICTED

special-to-type pin from the top and bottom ends respectively, of the main-plane slinging point just inboard of the strut pivot bracket (Sect.2, Chap.1). Insert the lifting eye-bolt through the slinging point (fig.16, detail A).

(12) Fit the lifting-ring lug to the radius-rod trunnion-boss (fig.16, detail B).

(13) Assemble the extension tube, the top sheath hook, the winch lower block, and the handle to the hoist (A.P.2187A). Connect the assembly between the eye-bolt and the lifting eye as illustrated. Take up the weight of the strut with the hoist.

(14) Withdraw the three bolts which secure the undercarriage pivot bracket saddle block.

(15) Remove the saddle block and the attached skin panel together, by withdrawing three countersunk bolts from the skin panel, two at the inboard edge and one at the outboard corner, and a ¼ in. dia. hexagon head bolt attaching the panel lug to spar 4, inside the undercarriage bay.

(16) Screw the sleeve of the pivot-pin extractor into the pivot pin. Insert the extractor rod through the sleeve and screw it down until the indicator hole in the rod is covered; steady the strut during this operation (fig.16, detail D).

(17) Unscrew the extractor rod and withdraw it from the sleeve.

(18) Unscrew the extractor sleeve from the pivot pin; withdraw the pin.

(19) Lower the strut, and with the axle pointing downwards, correctly position the strut on the ground (fig.16, detail C).

Assembly (fig.13 and 16)

46.

(1) Fit the undercarriage pivot pin into the strut ensuring that the threaded bore faces aft and that the forward end does not protrude beyond the bush.

(2) Fit the lifting-ring lug to the strut (fig.16, detail B).

(3) Attach the strut to the lifting equipment and hoist it into position. Tap the pivot pin into engagement with the pivot bracket and rotate it, using the peg spanner, until the grooves in the pin are aligned with the holes in the bracket; use the fixing bolts to check.

(4) Offer up the saddle block and skin panel and fit the panel securing bolts. Screw in the main securing bolts and tighten and wire-lock them.

(5) Dismantle the lifting equipment and fit the slinging point plug and special-to-type pin.

(6) Refer to para.44 (6) and connect the radius rod to the strut. Engage the down-lock.

(7) Fill and inflate the shock absorber (para.21).

(8) Fit the brake pressure and return hydraulic fluid pipes to the strut by attaching the swivel coupling. Connect the upper pipe-union nuts to the flexible pipes and wire-lock the unions.

Note...

◀ The fixing bolts must be tightened to a torque loading of 25 to 30 lb in. ▶  
It is essential that the swivel coupling assembly is so aligned that, after final tightening of the fixing bolts, no strain is imposed on the swivel joint.

(9) Fit the Maxaret unit and connect the hydraulic fluid pipes.

(10) Fit the brake unit (para.38) and the wheel (para.36).

(11) Fit the tension clips and the moulded rubber fairleads, which secure the pipes and the cables to the strut, (fig.15). The pipes must be positioned as close as possible to the aft upper fairing attachment lug.

(12) Carry out (4), (5) and (6) in para.42.

(13) Wire-lock the tension-clip pins.

(14) Carry out (7) to (13) in para.40.

(15) If a replacement strut has been fitted, check the wheel parallelism as follows:-

(a) Ensure that the down-locks on both the port and starboard main-undercarriage units are engaged.

(b) Suspend plumb lines from two

RESTRICTED

points, as widely separated as possible, along the aircraft centre-line. Set up a taut length of thread between the two plumb-lines so that it lies along the aircraft centre-line, and at a height approximately level with the wheel axle.

(c) On the inboard rim of each main wheel mark two points which are diametrically opposite. Set the wheel with the point horizontal.

(d) Join the forward point of one wheel rim to the corresponding point on the other with a steel measuring tape, and carefully measure the distance from the aircraft centre-line, as represented by the taut thread, to the rim of the wheel on the replacement strut.

(e) Repeat the previous measurement but with the tape joining the aft marked points on each wheel rim diameter.

(f) Compare the two measurements taken; if they differ by more than 0.125 in., the shimming of the torque link toggles (*fig. 1, detail A*) must be adjusted to effect wheel alignment.

(16) If a replacement strut is being fitted, adjustment will be necessary:-

(a) Remove the laminated shims by unscrewing the domed nut and withdrawing the pin at the centre pivot of the toggle assembly.

Note...

*Sufficient shims are supplied with the replacement strut for any necessary adjustment.*

(b) Peel-off shims as necessary.

(c) Assemble the pivot pin, spherical inserts and tighten the domed nut, ensuring no strain is imposed on the swivel coupling (8).

(d) Drill a 5/32 in. dia. hole through the centre of the nut and pivot pin, ensuring that the shackle pin, when fitted, will be at an angle of 45 deg to the centre line of the upper toggle (*fig. 1, detail A, view on arrow A*). Fit the shackle pin and collar with the collar uppermost and nearest the strut. Lock the shackle pin and collar with a new split pin.

(17) Retract the undercarriage slowly, using the hand pump, checking for fouls and correct functioning and ensuring the correct clearance is maintained at all points (*para. 30*). At the same time make a visual check, through the aperture for the unconnected fairing flap, that the flexible hydraulic fluid pipes are not trapped as the strut reaches the fully retracted position. If this occurs, slacken the unions on spar 4 and twist the flexible pipes to make them fit into the corner of the radius rod striker bracket, then tighten the unions and wire-lock them.

(18) Fit the shock-absorber fairing (*para. 42*).

(19) Lubricate (*fig. 20*).

(20) Carry out a functioning test (*Chap. 6*).

Wheel-well door

Removal

47.

(1) Disconnect the jack from the door.

(2) Remove the hinge pins (*fig. 2*) and detach the door from the main plane.

Assembly

48.

(1) Jack and trestle the aircraft (*Sect. 2, Chap. 4*).

(2) Connect a ground servicing trolley to services No. 1 hydraulic ground test connections.

(3) Connect a ground d.c. electrical supply.

(4) Hang the door on its hinges and secure the hinge pins.

(5) If a replacement door is being fitted:-

(a) Close the door manually and mark off the contour of the aperture. Open the door and trim accordingly until, with the door closed the correct gaps are maintained at all points (*fig. 9*). Check that the gaps do not decrease as the door leaves the aperture.

(b) Slacken the bolts of the strut support-pads and move the pads as far apart as possible.

(6) Check the door-jack override (para. 24).

(7) Check the setting of the door stops (para. 22).

(8) Check the door-locking mechanism (para. 23).

(9) If a replacement door is being fitted set the strut support pads:-

(a) Remove the shock-absorber fairing (para. 41).

(b) With the undercarriage fully retracted and the door locked, move the support pads to contact the strut casing, partially tighten the securing bolts.

(c) Lower the undercarriage and set each support pad one serration towards the other. Tighten and wire-lock the securing bolts.

(d) Fit the shock-absorber fairing (para. 42).

(10) Lubricate (fig. 20).

(11) Carry out a functioning test (Chap. 6).

#### NOSE UNDERCARRIAGE

##### Wheel

##### Removal

##### 49.

(1) Jack the nose undercarriage for wheel removal (Sect. 2, Chap. 4).

(2) Remove the locking plate and unscrew the ring nut from the axle pin.

(3) Support the wheel and withdraw the axle pin. The wheel is now free of the strut.

##### Assembly

##### Note...

Operation (1) to (3) below are applicable only if a replacement wheel is being fitted.

##### 50.

(1) Remove the axle from the unserviceable wheel after unscrewing the axle nut locking bolt, unscrewing the axle nut and removing the collar.

(2) Insert the axle into the hub of the replacement wheel, and fit the collar. Fit the axle nut and tighten it fully.

(3) Adjust the axle nut to give the wheel an end float of 0.005 to 0.010 in. using the appropriate method described below:-

(a) Check whether one of the five threaded holes in the axle nut lines up with one of the two holes in the axle. If so, unscrew the nut until the next hole in the nut is in line with the same hole in the axle, and fit the locking bolt.

(b) If two holes are not in line initially, unscrew the nut by the minimum amount necessary to achieve this. Then unscrew the nut until the first available hole in the nut lines up with the opposite axle hole, and fit the locking bolt.

(4) Position the wheel between the fork of the undercarriage strut and insert the axle pin from the starboard side.

(5) Fit the axle pin nut and lock it with the locking plate, nut and split pin.

##### Note...

The locking plate is reversible to facilitate correct assembly.

(6) Check the wheel for free rotation.

##### Retraction jack

##### Removal

##### 51.

(1) Jack and trestle the aircraft (Sect. 2, Chap. 4).

(2) Connect a ground servicing trolley to services No. 1 hydraulic ground test connections.

(3) Connect a ground d.c. electrical supply.

(4) Disconnect the rear door links by removing the two link pins.

(5) Remove the armament pack (Sect. 5).

(6) Detach the hydraulic fluid pipes from the shuttle valve and the jack body. Blank all pipe connections.

(7) Detach the jack ram from the strut.

(8) Remove the four bolts securing the jack trunnion bearings then withdraw the jack aft.

RESTRICTED

Assembly  
52.

- (1) Prepare the jack (*Chap.6*).
- (2) If a replacement jack is to be fitted, transfer the shuttle valve and the trunnion bearings from the unserviceable unit.
- (3) Fit the jack to frame 13. Bleed and connect the hydraulic fluid pipes (*Chap.6*).
- (4) Set the jack ram to give an override of 0.050 in. (*fig.17*) as follows:-
  - (a) Ensure the strut is fully locked down.
  - (b) With alighting gear selected DOWN, pressurize the hydraulic system to 3000 lb/in<sup>2</sup> to fully extend the jack.
  - (c) Slacken the adjuster locknut then alter the eye-end until it is aligned with the holes in the strut lugs.
  - (d) Lengthen the jack ram by altering the eye-end until, with the locknut tight, the setting pin Ref.No.26DK/95499 from the set Ref.No.26DK/95232 can just be inserted. Minor adjustments can be made by holding the eye-end clear of the strut lugs then, with the locknut slack and hydraulic pressure released, turning the jack ram using a C spanner. Turning the ram clockwise, looking on the ram in direction of arrow A, to leng-

then, and counter-clockwise to shorten.

(e) Remove the setting pin and wire-lock the locknut to the adjuster.

- (5) Retract the jack a small amount then connect it to the strut using the standard pin, nut, and new split pin.
- (6) Connect the rear door links to the door.
- (7) Lubricate (*fig.21*).
- (8) Fully retract and extend the undercarriage using the hand pump, checking for fouls and correct functioning.
- (9) Carry out a functioning test (*Chap.6*).
- (10) Disconnect the rear door links from the door.
- (11) Assemble the armament pack (*Sect.5*).
- (12) Repeat (6) ensuring that the link pins are correctly fitted and locked (*fig.19*).

Undercarriage strut (*fig.18*)

Removal

53.

- (1) Jack and trestle the aircraft (*Sect.2, Chap.4*).
- (2) Connect a ground servicing trolley to services No.1 hydraulic ground test connections.

(3) Connect a ground d.c. electrical supply.

(4) Remove the nose wheel (*para.49*).

(5) Disconnect the shimmy damper hydraulic fluid pipe from the saddle block on the strut pivot boss and the swivel coupling from the damper unit. Detach the pipe, coupling, and charging valve from the strut casing by withdrawing the two bolts from the charging valve housing. Blank off all the open ends of the unions.

(6) Detach the saddle block from the strut pivot boss by removing the two securing bolts.

(7) Remove the jack attachment pin and support the jack clear of the strut.

(8) Detach the rear-door operating links from the door by removing the link pins and secure the door so no foul will occur.

(9) Remove access panels 12P and 12S.

(10) Fit the jack adapter bracket used for nose-wheel changing and position an 8-ton pillar jack beneath the adapter (*Sect.2, Chap.4*). Raise the jack to support the shock absorber without raising the aircraft.

(11) Withdraw the split pin securing the pivot pin nut and unscrew the nut using a peg spanner Ref.No.26DK/95117.

(12) Screw the bolt of the pivot-pin extractor tool Ref.No.26DK/95079 into

the head of the pin and tighten the withdrawal nut to hold the sleeve of the tool against the undercarriage bracket.

(13) With at least two assistants to handle the strut, rotate the withdrawal nut to extract the pivot pin.

(14) Lower the pillar jack and manhandle the strut away from the aircraft.

#### *Preparing a replacement strut*

54. To prepare the strut:-

(1) Transfer the detachable sleeve from the pivot bush of the unserviceable strut; apply grease XG-287 before inserting it in the new strut.

#### **Note...**

*The sleeve is an airframe component and must not be returned to storage with the unserviceable strut.*

(2) Transfer the door links from the old strut using the new fastenings.

(3) Detach the axle from the new strut and exchange it with that in the wheel (para.50).

(4) Transfer the jacking attachment from the fork of the old strut.

#### *Assembly*

55. To assemble the strut:-

(1) Remove the down-lock jack by disconnecting the hydraulic fluid pipe and withdrawing four bolts. The electrical cable may be left connected.

(2) Fit thread guard Ref.No.26DK/95116 over the thread of the pivot pin and apply grease XG-287 to the assembly.

(3) Position the strut on the support jack.

(4) Raise the pillar jack slowly and guide the pivot boss between the undercarriage brackets and engage the lock plunger with the down-lock bracket.

(5) Line up the holes in the pivot bracket and the pivot boss, and insert the pivot pin from the starboard side.

(6) Remove the thread guard and fit the pivot pin nut. Tighten the nut with the peg spanner and fit a new split pin.

(7) Remove the pillar jack and the jacking adapter.

(8) Adjust the tapered lock plunger, using tool Ref.No.26DK/95240, to eliminate all backlash in the strut. The key engages a splined hole in the top of the plunger, and must be depressed to free the internal locking device, before the plunger can be rotated to effect adjustment.

(9) Fit the down-lock jack and tighten its securing bolts. Check for movement in the strut and, if backlash exists, remove the down-lock jack and readjust the plunger. Repeat this operation if necessary until the adjustment is correct. Check that the plunger locking device is correctly engaged after adjustment by half-engaging the tool and attempting to rotate the plunger.

(10) Wire-lock the down-lock jack securing bolts.

(11) Bleed the down-lock jack (Chap.6) and connect the pipe.

(12) With the strut fully locked down set the retraction jack override (para.52 (4)).

(13) Retract the jack a small amount, and fit the standard pin and nut using a new split pin.

(14) Fit the saddle block on to the pivot boss.

(15) Fit the charging valve housing to the strut casing and connect the hydraulic fluid pipe to the saddle block and the swivel coupling to the damper unit.

(16) Bleed the shimmy damper then charge the accumulator (Chap.6).

(17) Fit the wheel (para.50).

(18) Remove the forward door operating rods. Secure the doors so that no foul will occur.

(19) Using the hand pump, fully retract and extend the undercarriage, checking for fouls and correct functioning.

(20) Connect and set the forward and the rear doors (para.58).

(21) Lubricate (fig.21)

(22) Refit access panels 12P and 12S.

(23) Carry out a functioning test (Chap.6).

RESTRICTED

**Up-lock jack**

*Removal and assembly*

56. These operations are straightforward when the existing jack is being removed and refitted. If, however, a replacement jack is being fitted:-

(1) Jack and trestle the aircraft (Sect.2, Chap.4).

(2) Connect a ground-servicing trolley to services No.1 hydraulic ground test connections.

(3) Connect a ground d.c. electrical supply.

(4) Remove access panel 15.

(5) Prepare the jack (Chap.6).

(6) With the undercarriage fully retracted and pressurized to 3000 lb/in<sup>2</sup> insert the jack plunger into its cavity until it contacts the lock plunger in the strut.

(7) If a gap is apparent between the lock-jack flange and the up-lock bracket, pack the lock-jack flange with the special-to-type shims to a maximum thickness of 0.050 in.

(8) With the jack correctly seated, fit and wire-lock the securing bolts.

(9) Bleed and connect the hydraulic fluid pipe (Chap.6).

(10) Make the electrical connections.

(11) Fully retract and extend the undercarriage using the hand pump checking for correct unlocking and cockpit indication.

(12) Refit access panel 15.

(13) Carry out a functioning test (Chap.6).

**Nose undercarriage doors (fig.19)**

*Removal*

57.

(1) Forward doors:-

(a) Disconnect the operating rods from the doors.

(b) Remove access panels 4P and 4S.

(c) Remove the hinge bolts and detach the doors from the fuselage. On the forward hinges identify the shims and washers to ensure correct assembly.

(2) Rear door:-

(a) Disconnect the links from the door.

(b) Remove the hinge bolts and detach the door from the fuselage.

*Assembly*

58.

**Note...**

*When the nose undercarriage is retracted or extended singly, full system pressure must not be applied until the undercarriage is either locked in the up or down position by hand-pump pressure.*

(1) Jack and trestle the aircraft (Sect.2, Chap.4).

(2) Connect a ground servicing trolley to services No.1 hydraulic ground test connections.

(3) Connect a ground d.c. electrical supply.

(4) Forward doors:-

(a) Hang each door on the hinges with the shims and washers positioned correctly on the forward hinges. Secure and lock the hinge bolts.

(b) If a replacement door is being fitted, set the door correctly by shimming the forward hinge to suit. Trim the door until with the doors closed the correct gaps are maintained.

(c) Connect the operating rods to the doors but do not lock the nuts at this stage. Check that the aft hinge levers are in contact with the stops on the fuselage beams and that the doors are in a position that there is adequate clearance for the nose undercarriage to enter the undercarriage bay. It is permissible to file the stops accordingly.

(d) Disconnect the links from the rear doors and slacken the adjuster locknuts on the operating rods attached to the rear hinges of the nose undercarriage forward doors. ▶

(e) Fully retract the undercarriage using the hand pump and adjust the operating rods until the doors hang slack. Apply full system pressure (3000 lb/in<sup>2</sup>) with the ground servicing trolley. Maintaining pressure, adjust operating rods until doors are flush fitting with the fuselage and each other and contacting the landings without straining. Secure the adjuster locknuts on the operating rods and ensure that the turnbuckles are in safety.

(f) Lower undercarriage, ensuring that it does not foul the rear door. Disconnect operating rods from the nose undercarriage forward doors and connect the links to the nose undercarriage rear door.

**Note...**

*Before raising and lowering undercarriage with forward doors disconnected, it is essential that the operating rods are positioned on the aft side of the forward door rear brackets.*

(g) Fully retract the undercarriage using the hand pump and adjust links until the door hangs slack. Apply full system pressure (3000 lb/in<sup>2</sup>) with ground servicing

trolley. Maintaining pressure adjust links until the door is flush fitting with the fuselage without straining. Secure the adjuster locknuts on the links ensuring that the turnbuckles are in safety and wire-lock. (The undercarriage has to be lowered each time adjustments are made to the links.)

(h) Connect the forward operating rods alternately and with the undercarriage fully retracted check the clearance (0.050 ± 0.020 in.) between the stop bolts at the end of the forward doors and the stop brackets on the rear door. Adjust by altering the stops.

(j) Lower the undercarriage and connect and secure operating rods and links to their respective doors.

(k) Refit access panels 4P and 4S.

(5) Rear door:-

(a) Hang the door and with new tabwashers fitted secure and lock the hinge bolts.

(b) If a replacement door is being fitted fully retract the undercarriage and set the door correctly

on the hinges. It is permissible to remove 0.20 in. max. from the flanges of the hinge bushes accordingly. Trim the door skin until with the door closed the correct gaps are obtained.

(c) Repeat (4)(c); (d); (e); (f); (g); (h); (j) and (k).

(6) Fully retract the undercarriage using the hand pump, checking for fouls and correct sequencing of the doors and the cockpit indicator.

**Note...**

*Gaps between the landings and the door edges must be sealed with P.R.C. sealant applied to the landings. For details of the method of applying the sealant, refer to A.P.101B-1000-6.*

(7) Lubricate (fig.21)

(8) Carry out a functioning test (Chap. 6).

(9) Disconnect ground d.c. electrical supply.

(10) Disconnect ground servicing trolley, remake pump connections, wire-lock the couplings.

(11) Lower aircraft off jacks and trestles.

## RESTRICTED

TABLE 1  
Tools and equipment

Ref. Part No.	Description	Undercarriage	Application/remarks
4G/6246	Adapter, inflation Mk.2	} Main and nose	Shock-absorber charging
26DE/95162	Rig, pressure oil replenishing		Shock-absorber filling
26DK/95311	Nipple, grease	Main	Aft flap-actuating link lubrication
26DK/95283	Tool, setting	} Main	Door locking mechanism { Microswitch latch unit Plain latch unit Common to both units
26DK/95284	Tool, setting		
26DK/95285	Pin, setting		
26DK/95232	Box, container, setting pins, containing:-		
26DK/95497 EB2.88.4009	Pin, setting	Main	Not used
26DK/95498 EB2.88.4011	Pin, setting	Main	Door jack override
26DK/95499 EB2.88.4013	Pin, setting	Nose	Retraction jack override
26DK/95082	Spanner, peg	} Main	Wheel, retaining nut
26DK/95708	Extractor		Wheel
27G/6804	Fixture		Wheel brake alignment
26DK/95078	Tool, extractor	} Main	Strut pivot pin
26DK/95080	Spanner, peg		
4GC/5443	Tube, extension 36 in.	} Main	Strut slinging
4GC/5699	Hoist, aircraft heavy component, 2½ cwt		
4GC/5700	Top sheath, (Type No.1) hook, 2½ cwt		
4GC/5701	Block, winch lower, double purpose		
4GC/5743	Handle, winch 9 in.		
26DK/95088	Extractor, special pin		
26DK/95108	Eyebolt		
26DK/95433	Ring, lifting	} Nose	Strut pivot pin
26DK/95079	Tool, extractor		
26DK/95116	Guard, thread		
26DK/95117	Spanner, peg		
26DK/95240	Tool, adjusting		

RESTRICTED

TABLE 2  
Major components

Component	Type or Part No.	A. P. Reference					
		Qty.	A. P.	Vol.	Sect.	Chap.	App.
<b>Main undercarriage</b>							
Shock absorbers							
Port	Dowty Rotol 2.00.384.001 (pre Mod.4375)	1	1803T	1 (Bk.1)	2	5	5
	Dowty Rotol 2.00.384.007 (post Mod.4375)						
Starboard	Dowty Rotol 2.00.385.001 (pre Mod.4375)						
	Dowty Rotol 2.00.385.007 (post Mod.4375)						
Radius rod							
Port	◀ 2.00.357.028 (pre Mod.4744)	1	104-1027-16AC				
	2.00.357.032 (post Mod.4744)						
Starboard	2.00.358.028 (pre Mod.4744)						
	2.00.358.032 (post Mod.4744) ▶						
Brake unit							
Port							
Starboard	Refer to Chap.6						
Maxaret unit							
Port							
Starboard	Refer to Chap.6						
Wheel							
Port and starboard	pre Mod.4033 post Mod.4033	1 each	2337	1	1	1	
	Dunlop 52261 Dunlop 52268						
Tyre							
Port and starboard	Dunlop DRR3595T	1 each	2337	1	2	-	-
<b>Nose undercarriage</b>							
Shock absorber	◀ Dowty Rotol 2.00163.015 ▶	1	1803V	1	6	5	-
Wheel	Dunlop AH52017	1	2337	1	1	5	90
Tyre	Dunlop DF3881T	1	2337	1	2	-	-

TABLE 2  
Major components

Component	Type or Part No.	Qty.	A. P. Reference					
			A. P.	Vol.	Sect.	Chap.	App.	
<b>Main undercarriage</b>								
Shock absorbers								
◀ Port	Dowty Rotol 2.00.384.001 (pre Mod. 4375)	1	1803T	1 (BK. 1)	2	5	5	
	Dowty Rotol 2.00.384.007 (post Mod. 4375)							
Starboard	Dowty Rotol 2.00.385.001 (pre Mod. 4375)	1	1803T	1 (BK. 1)	2	5	5	
	Dowty Rotol 2.00.385.007 (post Mod. 4375)							
Radius rod								
Port	2.00.357.020 (pre Mod. 4220)	1	104-1027-16AC					
	2.00.357.022 (post Mod. 4220)							
	2.00.357.024 (post Mod. 4404)							
Starboard	2.00.358.020 (pre Mod. 4220)	1	104-1027-16AC					
	2.00.358.022 (post Mod. 4220)							
	2.00.358.024 (post Mod. 4404)							
Brake unit								
Port								
Starboard	Refer to Chap. 6							
Maxaret unit								
Port								
Starboard	Refer to Chap. 6							
Wheel								
Port and starboard	pre Mod. 4033 Dunlop 52261	1 each	2337	1	1	1	1	
	post Mod. 4033 Dunlop 52268							
Tyre								
Port and starboard	Dunlop DRR3595T	1 each	2337	1	2	-	-	
<b>Nose undercarriage</b>								
Shock absorber								
	Dowty Rotol 2.00163.004	1	1803V	1	6	5	-	
Wheel	pre Mod. 2136 Dunlop AH50748	1	2337	1	1	5	90	
	post Mod. 2136 Dunlop AH52017							
Tyre	Dunlop DF3881T	1	2337	1	2	-	-	

This file was downloaded  
from the RTFM Library.

Link: [www.scottbouch.com/rtfm](http://www.scottbouch.com/rtfm)

Please see site for usage terms,  
and more aircraft documents.

