

CHAPTER 1

SAFETY PRECAUTIONS, PARTS, STRIPPING AND ASSEMBLY

Introduction

1. The object of weapon training is to train cadets to handle a rifle safely and confidently and become good riflemen. Whenever possible, the range courses detailed in Chapter 7 are to be fired by cadets.
2. The .22 rifle is ideal for the purpose and also enables continuation training to be carried out indoors in the winter evenings and during inclement weather when the use of outdoor ranges is impracticable. All cadets should fire their entitlement of ammunition each year to achieve and maintain their small arms efficiency. The training is so phased that they are allowed to fire the .22 rifle as soon as possible, so stimulating their interest.

Equipment

3. The scale of equipment for weapon training is laid down in AP 1896. Other equipment such as aiming rests, eye discs and dummy targets can be improvised, and this calls for resource and initiative.
4. The following chapters refer to the .303 No 4 rifle which is issued for shooting training. Instructors should acquaint themselves with the differences in construction of the No 4 rifle and the No 1 rifle which is issued for drill purposes. Most of the training at squadrons can be carried out using No 1 rifles, and the No 4 rifle should be explained to cadets before they carry out their shooting practices.

Teaching of Safety Precautions

5. The most scrupulous attention is to be paid to the safety precautions which follow. These precautions are to be repeated again and again throughout the training usually by question and answer, until the safe handling of firearms becomes second nature and a habit. *IT IS ONLY BY THE STRICTEST ADHERENCE TO THESE SAFETY PRINCIPLES THAT ACCIDENTS WITH LIVE AMMUNITION WILL BE AVOIDED.*
6. Explain that the following safety precautions will be carried out at the beginning and end of every lesson or practice:
 - a. Prove all rifles and inspect all drill rounds.
 - b. Allow the squad to inspect your own rifle and drill rounds.
7. Explain how easy it is to kill or injure a comrade by mistake. The following rules apply to *ALL* weapons, not only rifles, and are emphasized in all weapon training:
 - a. Never point any weapon at a comrade. This is very often forgotten when carrying arms from place to place.
 - b. Never load a weapon until ordered to do so.
 - c. Always apply the safety catch as soon as you have loaded.
 - d. The moment you no longer need your weapon loaded, unload it.
 - e. Whenever you pick up a weapon, whether your own or someone else's, always look to see if it is loaded.
 - f. When you hand a weapon to someone else, check that it is unloaded, show him that it is unloaded and hand it over with the muzzle pointing straight up in the air. When anyone hands a weapon to you, insist that he does the same.

THE RIFLE, CHAP 1

- g. Never play with firearms or point a weapon at anyone in jest.
 - h. Never use drill rounds when aiming at eye discs held to the eyes of other personnel.
 - j. Never lean a rifle, whether loaded or unloaded, against a wall or any other object. If it falls to the ground it may kill someone, or, at the very least, suffer damage which will affect its accuracy.
 - k. Remember that the .303 rifle is dangerous up to a range of two miles, and the .22 rifle up to one mile.
8. Explain that the rifles which are being used are "Drill Purpose" and have been so designed as a further safety measure. Briefly explain the differences between a DP and a normal rifle.
9. Emphasize that during training DP rifles are to be handled, and all safety precautions observed, as if they were normal rifles. Carelessness with, and abuse of DP rifles is forbidden.

Naming the Parts, Stripping

10. Name the parts. (Fig 1, 2, 3 and 4)
11. Explain and demonstrate, making the squad copy your actions:
- a. Ensure that the rifle is unloaded.
 - b. Check that the number on the bolt is the same as the number on the left hand side of the body.
 - c. Remove the sling.
 - d. Remove the bolt:
 - (1) Raise the backsight.
 - (2) Push forward the safety catch.
 - (3) Release the bolt-head from its slide (as appropriate to the mark of rifle), turn it upwards, then withdraw the bolt.
 - (4) Lower the backsight.
 - e. Press up the magazine catch and remove the magazine.
 - f. Press down the wide end of the magazine platform until the narrow end is clear of the front lips. Lift out the magazine platform and spring, narrow end first.
 - g. Open the butt trap, and take out the pull-through and oil bottle.

Assembly

12. The Bolt.
- a. Ensure that the rifle and bolt numbers agree. The rifle will not shoot accurately if fitted with the wrong bolt.
 - b. Check that the bolt head is screwed fully home and that the bolt lug and cocking-piece are in line.
 - c. Put the safety catch in the forward position.
 - d. Raise the backsight.
 - e. Insert the bolt in the rifle. When clear of the guide, turn down the bolt head and engage it with its slide (as appropriate to the mark of the rifle). Push the bolt fully home and turn the bolt lever fully downwards.
 - f. Holding the small of the butt firmly with the right hand, press the trigger gently with the right forefinger. Pause when you feel the check. This is the

SAFETY PRECAUTIONS, PARTS, STRIPPING AND ASSEMBLY

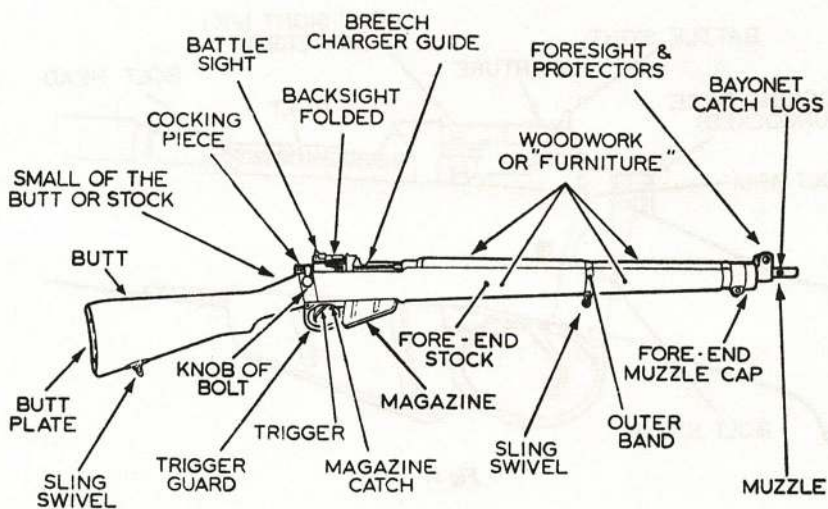

Fig 1.

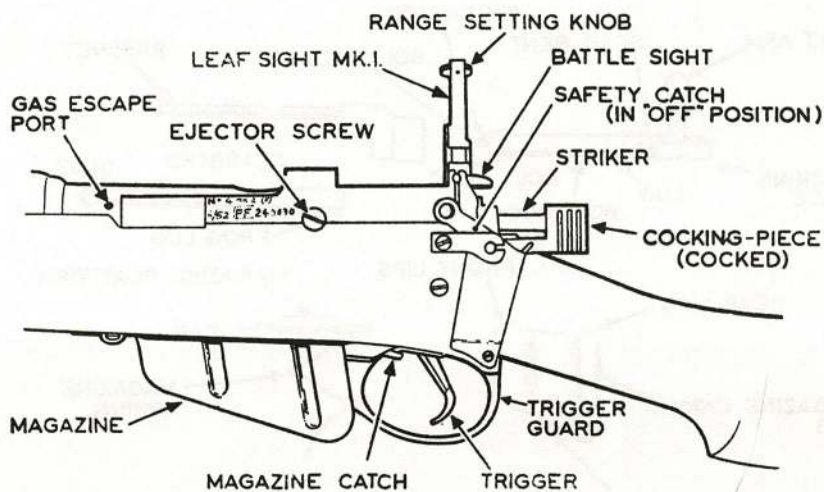

Fig 2.

THE RIFLE, CHAP 1

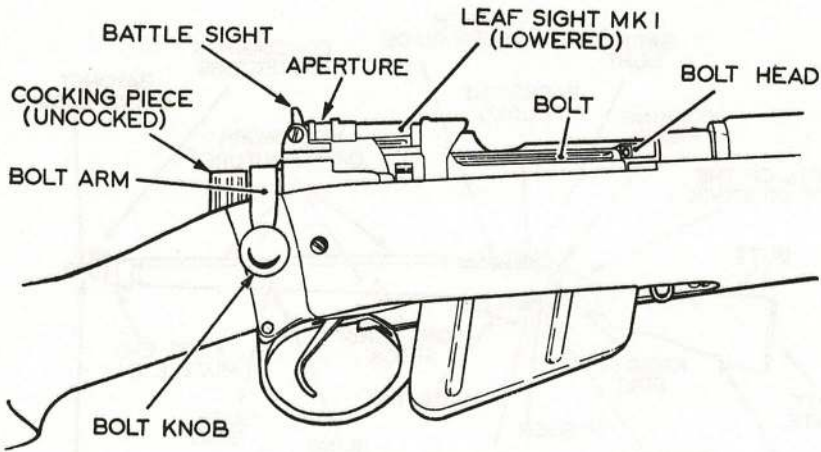

Fig 3.

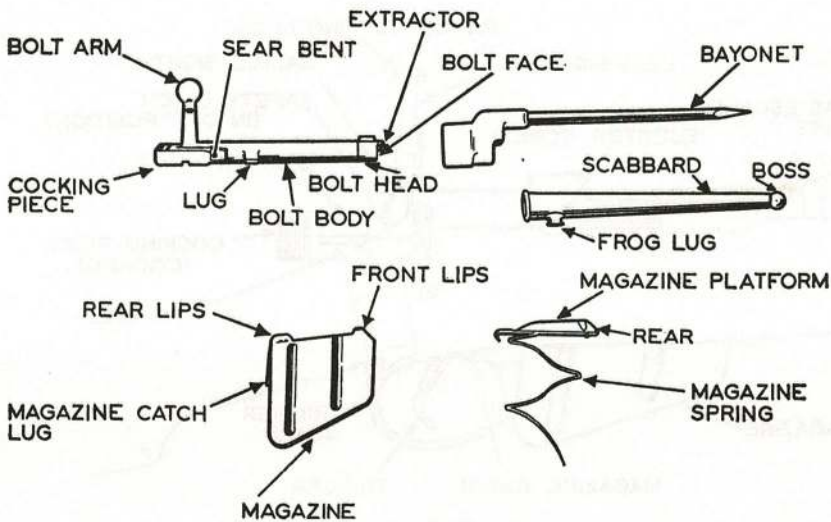

Fig 4.

SAFETY PRECAUTIONS, PARTS, STRIPPING AND ASSEMBLY

first pressure. Continue to press after feeling the check. This is the second pressure which will release the cocking-piece and allow the striker to move forward under the pressure of its spring.

g. Apply the safety catch by rotating it to the rear with the forefinger on the right hand. While doing this, the remaining three fingers of the right hand should press down on the bolt lever to ensure that it is fully down.

h. If the cocking-piece remains half way forward (the half cock), pull it back, open the bolt, see that the chamber is clear, close the bolt and repeat "f" above.

13. The Magazine.

a. Replace the platform, wide end first, allowing the spring to sink into the magazine body below it. Press down the wide end of the platform tilting it slightly backwards so that the narrow end slips under the lips.

b. Test the magazine by pressing down on the platform and ensuring that the spring returns it to its highest position.

c. Replace the magazine until the retaining catch engages. Test for security by pulling downwards.

14. *CHECK SAFETY PRECAUTIONS.*

CHAPTER THREE: THE HISTORY OF THE UNITED STATES

The history of the United States is a story of growth and change. It is the story of a nation that has grown from a small colony to a world power. The story is one of struggle and triumph, of hope and despair. It is a story that has shaped the world and continues to shape it today.

The story begins with the first settlers who came to the Americas. They were explorers and adventurers, seeking new lands and new opportunities. They found a land of vast resources and a people who were different from anything they had ever seen before.

As the years passed, the settlers grew in number and their influence grew. They built a nation that was based on the principles of freedom and democracy. They fought for their rights and won. They created a new way of life that was better than anything that had ever existed before.

The story of the United States is a story of progress and achievement. It is a story of a nation that has overcome all odds and has become a world leader. It is a story that has inspired millions of people and has shown the world what is possible when a people are united in purpose and determined to succeed.

The story of the United States is a story of hope and optimism. It is a story of a nation that has always looked to the future and has always been ready to embrace change. It is a story that has shown the world that a better life is possible and that a brighter future is within reach.

The story of the United States is a story of a nation that has always been a beacon of light and a source of inspiration. It is a story that has shown the world that a better world is possible and that a brighter future is within reach. It is a story that has inspired millions of people and has shown the world what is possible when a people are united in purpose and determined to succeed.

THE HISTORY OF THE UNITED STATES

This file was downloaded
from the RTFM Library.

Link: www.scottbouch.com/rtfm

Please see site for usage terms,
and more aircraft documents.

