

CHAPTER III.—MEASURING INSTRUMENTS

MEASUREMENT OF DIRECT CURRENTS AND CONSTANT VOLTAGES

1. The electrical quantities which commonly require measurement in D.C. circuits are (i) the current flowing, (ii) the P.D. between various points in a circuit, (iii) the rate at which energy is being converted, i.e. power being supplied or consumed, (iv) the total energy supplied over a given period. Instruments used for measuring current are called ammeters, special forms used for the measurement of small currents being termed milliammeters and microammeters. Instruments used for the measurement of P.D. are called voltmeters, millivoltmeters being in occasional use. The measurement of power is accomplished by the employment of the watt-meter, while instruments which measure the total energy supplied or consumed over a given period are termed energy meters or watt-hour meters. In this chapter it is proposed to describe certain types of all these instruments, chiefly from the aspect of D.C. measurement, although in certain instances the instrument is suitable for use in either A.C. or D.C. circuits.

Requirements of ammeters and voltmeters

2. The following properties are desirable in these instruments, whether used for D.C. or A.C.

(i) They should be "dead-beat" in action. The term dead-beat means that when a given current passes through the meter, or a given P.D. is applied to it, the pointer should immediately register the correct reading and not oscillate on either side of it for an appreciable period. A dead-beat instrument is said to be efficiently "damped", and the steps taken to ensure this in different types of instruments are detailed later.

(ii) They should retain the accuracy of their calibration, always returning to zero when no current flows, and having inappreciable error if used at a temperature differing from that at which calibration was performed.

(iii) The scale should be divided uniformly.

(iv) External electric or magnetic fields should not influence the deflection.

The British Standards Institution recognises three grades of ammeters:—Sub-standard instruments, which are used for calibration purposes, and have an accuracy within ± 0.5 per cent. 1st Grade, and 2nd Grade, with permissible errors, depending upon the working conditions, of from 1 to 2 per cent. and 2 to 4 per cent. respectively. Voltmeters are similarly graded, but the tolerated errors are smaller since the current flowing, and therefore the heat developed, is less. Grade I and Grade II instruments may be calibrated by comparison with sub-standards, and are used for ordinary switchboard requirements.

3. (i) We have already seen that the effects of a current are chemical, thermal and magnetic. Ammeters and voltmeters may be made to operate by any one of these effects. The chemical effect is however ill-adapted for use in a direct reading or "deflectional" instrument, i.e. one which is provided with pointer and scale. Practical direct reading ammeters therefore make use of either the thermal or the magnetic effect.

(ii) The simplest form of current-indicating instrument is the galvanometer which has already been described. The principle used therein, namely the deflection of a suspended or pivoted bar magnet by the field produced by an electric current, is rarely if ever adopted when actual current measurement is required, but the moving coil instrument, presently to be described, is really an inversion of the principle, a powerful fixed magnet causing the deflection of a current-carrying coil. Before proceeding further it is desirable to emphasise that instruments depending upon the deflection of a magnet by a current-carrying coil or vice versa, measure the average value of the current, and give no deflection when an alternating current flows through the conductor. Taking the simple galvanometer as an example, a moment's reflection will shew that if the current is alternating, the magnetic needle will tend to oscillate, turning alternately

CHAPTER III.—PARAS. 4-5

to the left or right hand as the current changes its direction. The inertia of the needle is too great to allow it to perform such changes, at any rate if the change in the direction of the current occurs more than once or twice per second, and therefore the needle remains stationary when such a current is applied to the coil.

(iii) Instruments which depend upon the thermal effect of a current, however, actually measure the rate at which heat is being produced in the instrument, and the deflection of the pointer is proportional to the power dissipated in the instrument, and therefore to the square of the current. From fundamental principles it is apparent that the heat developed in any conductor is independent of the direction of the current, and depends only upon its magnitude. The "square law" above mentioned is the mathematical expression of this physical fact, for the square of the current is always positive, irrespective of the sign, positive or negative, which we arbitrarily assign to its direction. In general, it may be stated that instruments which give a deflection proportional to the average value of the current are suitable for use in direct current circuits only, while those which give a deflection proportional to the mean value of the square of the current are suitable for measurement of either direct, alternating or pulsating currents.

Fundamental principles of instrument design

4. Certain fundamental considerations apply to all types of indicating instruments. In every such instrument there is a moving part of light and therefore delicate construction which is pivoted in jewelled bearings, and this moving member carries the pointer, which moves over a graduated scale. The pointer must be extremely light and yet very rigid, and is generally made from thin aluminium sheet which is drawn into a channel section to attain the desired rigidity, while another design utilises thin aluminium wire which is built up into a rigid structure by cross bracing, hence it is usually called the "girder" type of pointer. If instruments must be opened for repair, the utmost care must be exercised to avoid damage to any part of the moving member. The current passing through the meter, which is proportional to the current or voltage to be measured, sets up a torque or turning moment which causes the moving part to rotate. This actuating torque always increases with the current passing through the instrument, but is not necessarily in strict proportion thereto, although it is so in the moving coil instrument if the magnetic field is correctly distributed. In order to obtain a steady deflection for a given current through the instrument, some opposing torque must be introduced by the rotation of the moving part, and this, which is called the restoring torque because it tends to return the pointer to its initial position, must increase with the angle through which deflection occurs. The pointer will then come to rest at some definite position, called the position of equilibrium, at which the actuating torque and restoring torque are equal.

5. (i) The restoring torque is normally provided by either of two methods, viz. : gravity control or spring control. Gravity control is achieved by attaching to the moving member a light arm carrying a small weight ; the arrangement is such that the weight occupies its lowest possible position when the pointer is at the zero of its scale. When the pointer is deflected the arm carrying the weight is inclined to the vertical, and the force of gravity acts upon the weight, producing a torque which tends to turn the pointer to zero. The restoring torque is shewn by the diagram (fig. 1), to be equal to $w x$ units, the unit of force usually used being the gram, and the unit of length the centimetre. Hence the restoring force may be said to be $w x$ gram-centimetres. From the diagram it will be seen that if the weight is mounted r centimetres from the pivot, $x = r \sin \theta$ where θ is the angle through which it has been deflected. The restoring force is equal to $w r \sin \theta$ gram-centimetres, and is therefore proportional to $\sin \theta$, and the scale division varies accordingly. The effect of this is to limit the useful range of movement of the pointer to about 80° . Gravity control is most commonly applied in moving iron instruments of the switchboard type.

(ii) The second method, spring control, is invariably used in the design of moving coil instruments. The springs used are flat spiral springs similar to the hair spring which controls the balance wheel of a watch, and the torque exerted by this form of spring is directly proportional to the angle through which it is twisted, hence this spring control gives a restoring torque which is

directly proportional to the angle through which the pointer is deflected. In certain A.C. meters in which this form of control is used, the pointer has a movement of 300° , but in ordinary designs about 120° is rarely exceeded.

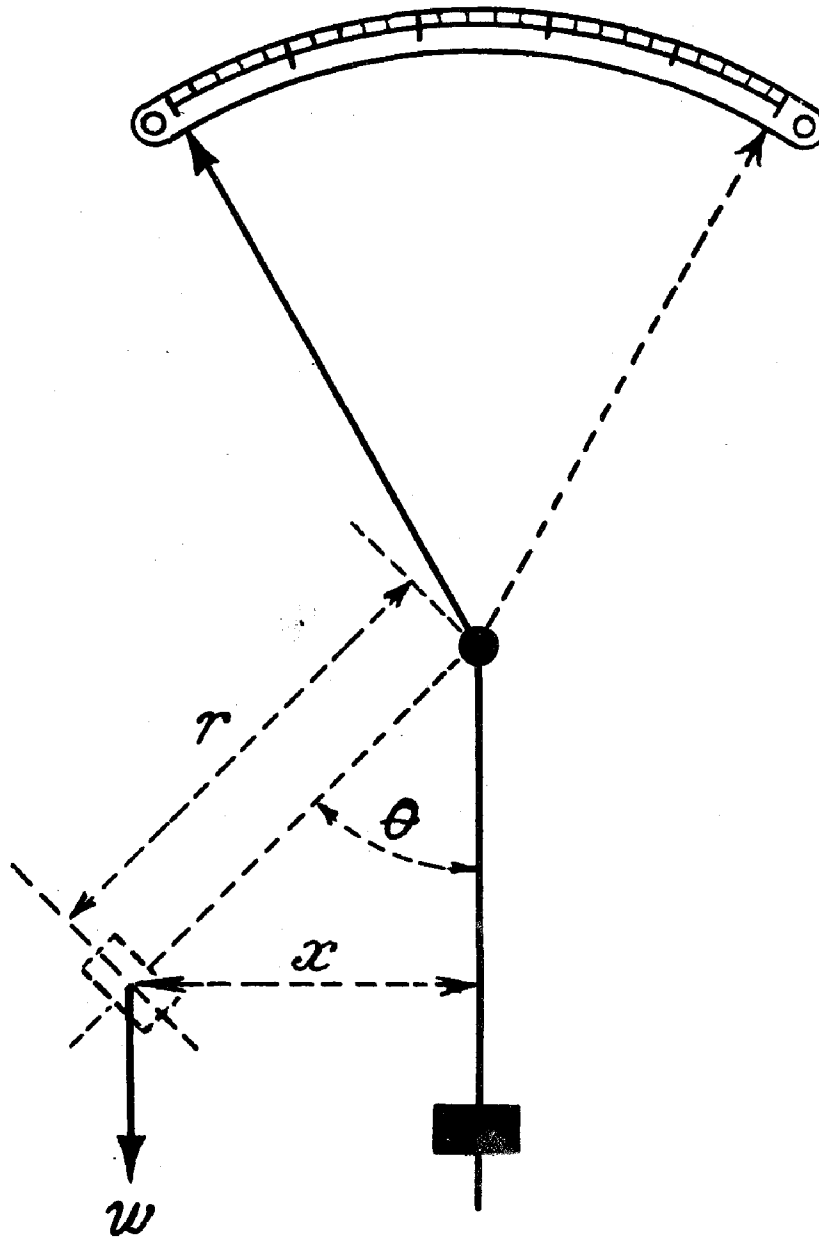

FIG. 1, CHAP. III.—Gravity control.

Moving coil instrument

6. A coil carrying a current is equivalent to a magnet and if placed in a magnetic field will tend to turn into the position in which it embraces maximum flux. This principle is used in the construction of moving coil instruments, as shown diagrammatically in fig. 2. The magnetic field is provided by a permanent magnet (A), and a soft iron core (B) is mounted between its poles, this serving to concentrate the flux in the air gap, and to cause it to pass through the gap radially. The sides of the moving coil (C) are then always normal to the flux, no matter in what

CHAPTER III.—PARA. 7

position the coil may be, and the deflection is truly proportional to the current in the coil. The coil is wound on a light metal former, and current is led to and from the windings by spiral springs (S) which also act as the controlling device. The restoring force of these springs is proportional to the angle through which the coil has turned from its zero position. When current flows, therefore, the coil takes up a position of equilibrium, in which the torque due to the current is exactly balanced by the resisting torque of the spring. The instrument thus has an evenly divided scale and fulfils requirement (iii).

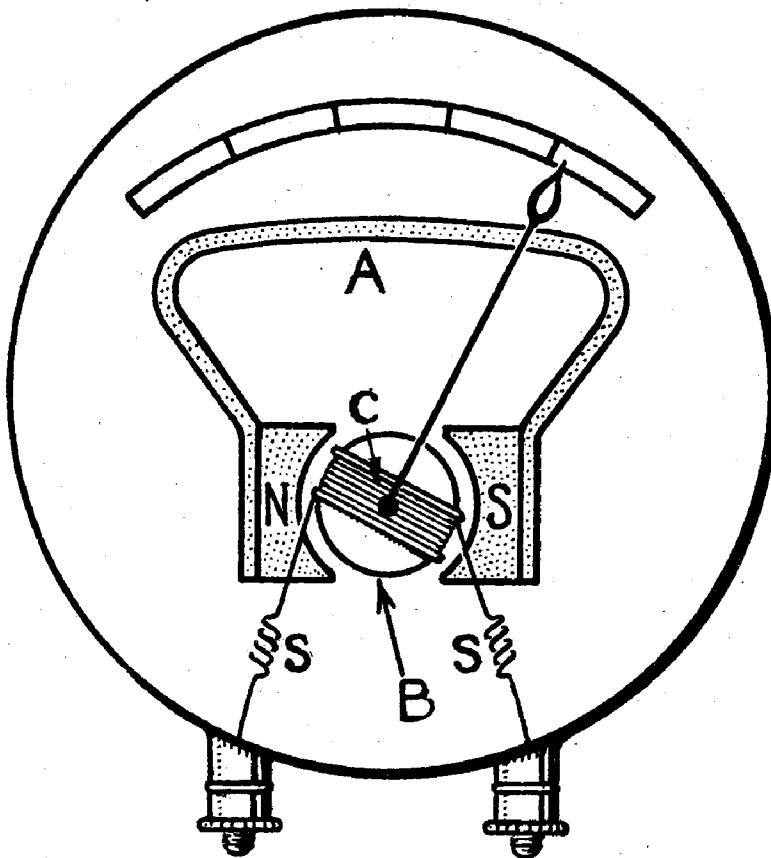

FIG. 2, CHAP. III.—Principle of moving coil instrument.

When in motion the metal former has induced in it an E.M.F. which by Lenz's law tends to oppose the motion which produced it, and thus acts as a damping device. The lightness of coil and pointer also contribute towards the achievement of effective damping. Requirement (iv) is also nearly fulfilled, for as the magnetic field set up by the permanent magnet is very strong, external magnetic fields have little effect. Nevertheless, such an instrument should not be mounted too near to a dynamo or motor. The zero of the instrument is practically unaffected by temperature, and since the permanent magnet and the controlling springs retain their original properties over a long period, the calibration remains very nearly constant. Moving coil instruments can therefore be obtained as sub-standard or any lower grade.

Moving iron instrument

7. (i) Though not as accurate as the moving coil instrument, this type is of simpler and more robust construction. Two kinds are in general use, the attraction type and the repulsion type. Fig. 3 shews the principle of the attraction type. (A) is a fixed coil carrying the current to be measured, and (B) is a disc of soft iron eccentrically pivoted and carrying a pointer. When a

current flows in (A), (B) becomes magnetised and being pivoted eccentrically moves into the coil, causing a deflection of the pointer. The controlling torque is usually provided by a spring (not shown). Air damping is also provided by a piston (C) moving in a cylinder (D). The deflection is proportional to the square of the current, and the scale is therefore cramped at its lower end.

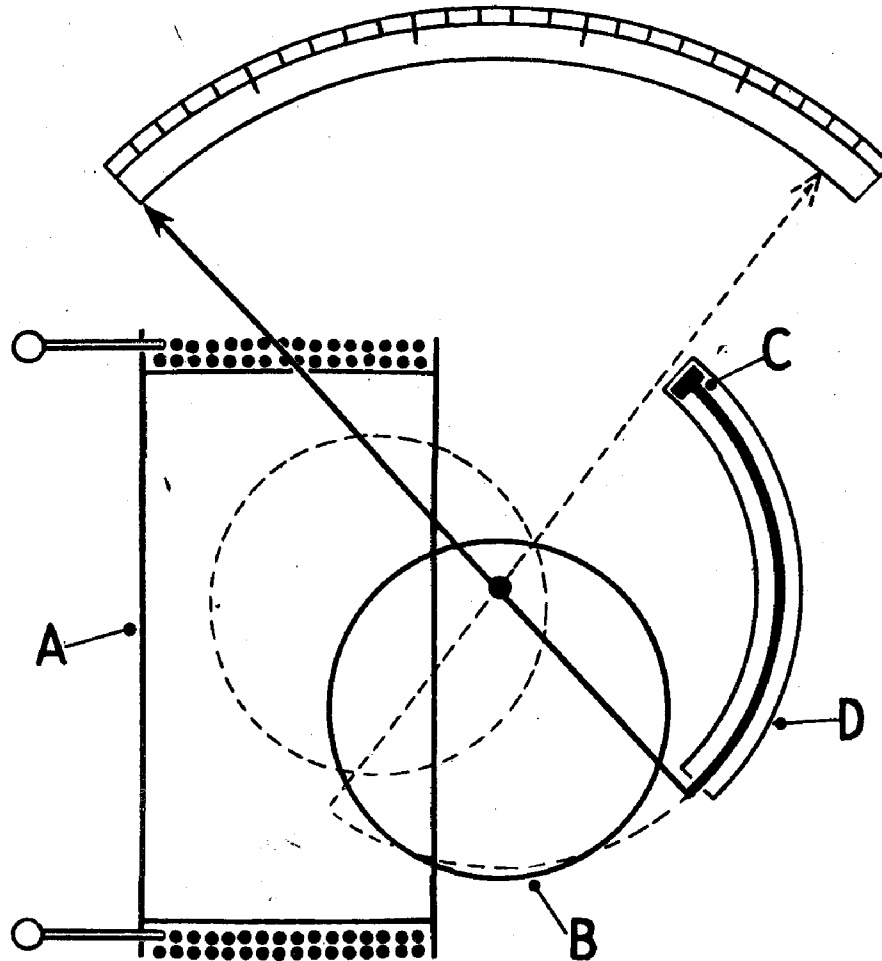

FIG. 3, CHAP. III.—Principle of moving iron instrument (attraction type).

(ii) The principle of the repulsion type is exhibited by fig. 4. Two pieces of soft iron are arranged inside and parallel to the axis of a circular magnetising coil (A) carrying the current to be measured. One of the pieces (B) is of uniform breadth and is attached to a pivoted spindle carrying the pointer. The other piece (C), which is fixed to the case, is curved to a circular arc and is tapered in breadth. Under the magnetising force of the current both pieces of iron become similarly magnetised, and the smaller piece will be repelled from the wide to the narrow end of the larger, the movement being controlled by a flat hair-spring (D). The deflection will be proportional to the square of the current, and consequently the scale will not be uniformly divided. Moving iron instruments are subject to influence by external fields, which however can be much reduced by enclosure within an iron case. Their readings are also subject to error due to hysteresis.

Hot-wire instrument

8. This is shown diagrammatically in fig. 5. (A) is a wire of high melting point and high specific resistance, platinum-silver or iridium-platinum being commonly employed. One end of

CHAPTER III.—PARA. 9

a phosphor-bronze wire (B) is attached to the centre of the wire (A), the other end being attached to an insulated post (C). A silk fibre is attached to (B), passing round a small pulley (D) which carries a pointer, and is kept in tension by a spring (E). One end of the wire (A) is connected to the metal base plate at (F), the other to an insulated post (G). The action of the instrument is as follows :—When a current flows through (A), the wire expands and sags, this sag being taken up by the wire (B) and the spring (E), thus rotating the pulley (D) so that the pointer moves over the graduated scale. The heating effect of the current is proportional to the square of the current, so that the expansion and consequently the pointer deflection, also varies as I^2 . The scale is therefore cramped at the lower end and requirement (iii) is not fulfilled by hot-wire instruments. They also tend to have an uncertain zero error, due to the wire failing to return to room temperature for a considerable period after current has ceased to flow, while the length

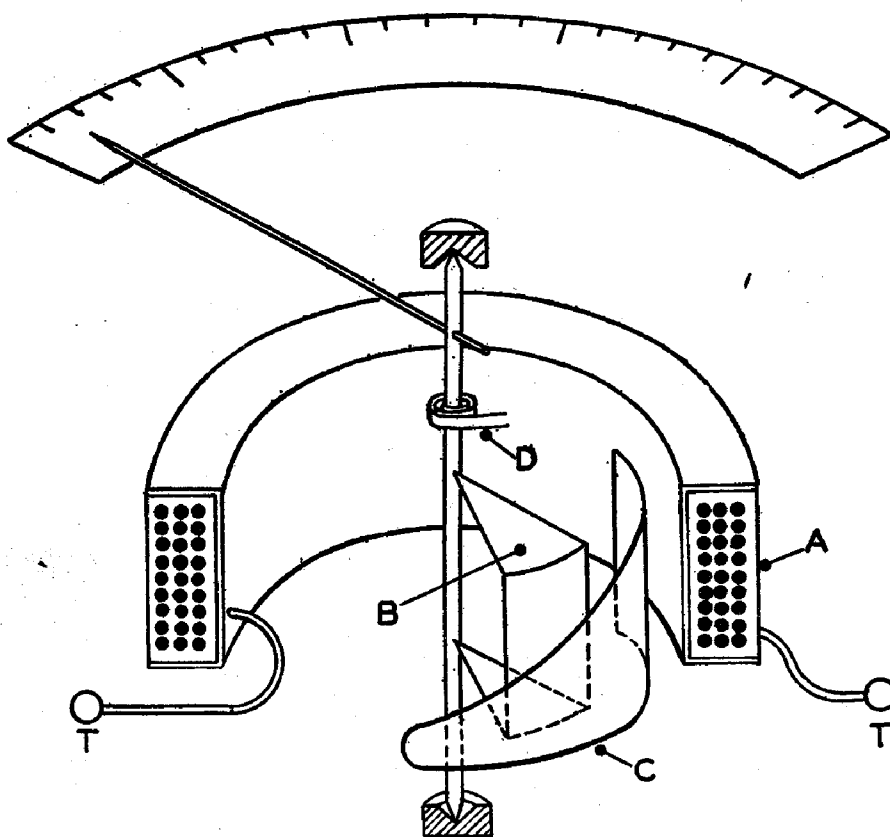

FIG. 4, CHAP. III.—Principle of moving iron instrument (repulsion type).

of time taken to heat the wire to a steady temperature renders the instrument sluggish in action. A simple device which alters the tension of the wire (A) in order to correct the zero error is shown at (F) in fig. 5. Hot-wire instruments are regarded only as 2nd Grade instruments, and are rarely used for D.C. measurements. Damping is introduced into these instruments by a metal disc (H), carried on the spindle of the pulley (D). When the pulley rotates the disc moves between the poles of a permanent magnet (J). Eddy currents are thus induced in the disc, and these eddy currents inter-acting with the magnetic field, tend to turn the disc in the opposite direction to that in which it is moving.

Connections for use as ammeter or voltmeter

9. The foregoing pieces of apparatus were referred to as "instruments", because the principles embodied therein can be applied to the measurement of either P.D. or current. The

difference between an ammeter and a voltmeter of the same type is entirely due to their different functions. An ammeter is required to measure current, and must be inserted in series with the circuit in which the measurement is to be made. It must therefore be of low resistance compared with the remainder of the circuit, otherwise the insertion of the ammeter will alter appreciably the current flowing, and also lead to a loss of power in the instrument itself. A voltmeter measures P.D., and must be connected between the points whose P.D. is required. It must therefore have a high resistance so that the extra current taken by the instrument will not lower the P.D. appreciably, and also to reduce the power loss in the instrument itself. In practice the same instrument may be used either as a voltmeter or an ammeter, in combination with suitable resistances. It must of course be calibrated in accordance with the use for which it is intended. Taking the moving coil type as an example, it is usual to manufacture a standard instrument which

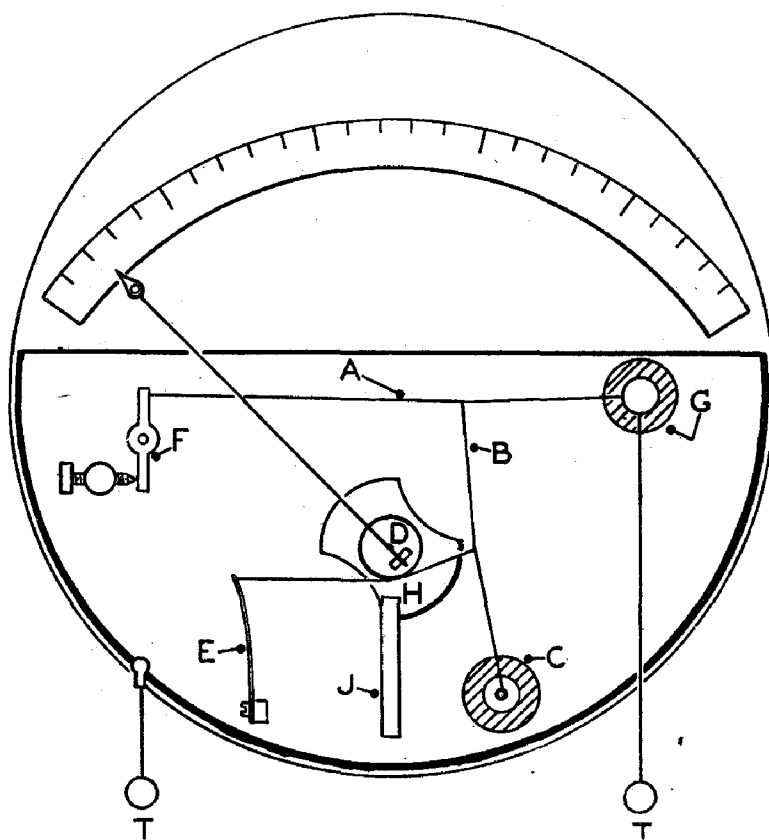

FIG. 5, CHAP. III.—Principle of hot wire instrument.

usually requires about $\cdot 01$ ampere to give full scale deflection, the total resistance of the instrument being say 5 ohms. If it is required to measure up to 10 amperes, it is necessary to connect a resistance in parallel with the instrument of such a value that 9·99 amperes will flow in the parallel resistance and only $\cdot 01$ ampere through the moving coil. A resistance used in this way is called an ammeter shunt (fig. 6a). The correct value of the shunt resistance is easily found, for the P.D. between its ends, and the current flowing in it are both known. As the instrument has a resistance of 5 ohms and takes a current of $\cdot 01$ ampere, the P.D. must be $\cdot 05$ volt, and the resistance of the shunt is $\frac{\cdot 05}{9\cdot 9} = \cdot 00505$ ohms. An ammeter shunt usually consists of one or more

rectangular sheets of manganin, the ends being hard-soldered into heavy copper blocks to which the instrument leads are attached. For currents up to about 20 amperes the shunt is generally contained in the case of the instrument and this practice is of course compulsory in portable

CHAPTER III.—PARAS. 10-11

instruments. For switchboard use the shunt may be fitted externally, the connecting leads being also supplied. It is essential that these should not be shortened or the calibration may be seriously affected.

10. When an instrument is to be used as a voltmeter, a series resistance must be used with it (fig. 6b). Suppose it is required to use the above instrument to measure P.D. up to 240 volts. The total resistance must then be such that 240 volts will just cause a current of .01 ampere, and the total resistance of the voltmeter must be 24,000 ohms. As the instrument has a resistance of only 5 ohms, it is necessary to connect a resistance of 23,995 ohms in series with it. The appropriate resistance is incorporated in the case of portable instruments but is often mounted separately if the voltmeter is designed for switchboard use. It is usually of eureka wire wound on flat mica strips, or sometimes upon a porcelain or hard-wood bobbin.

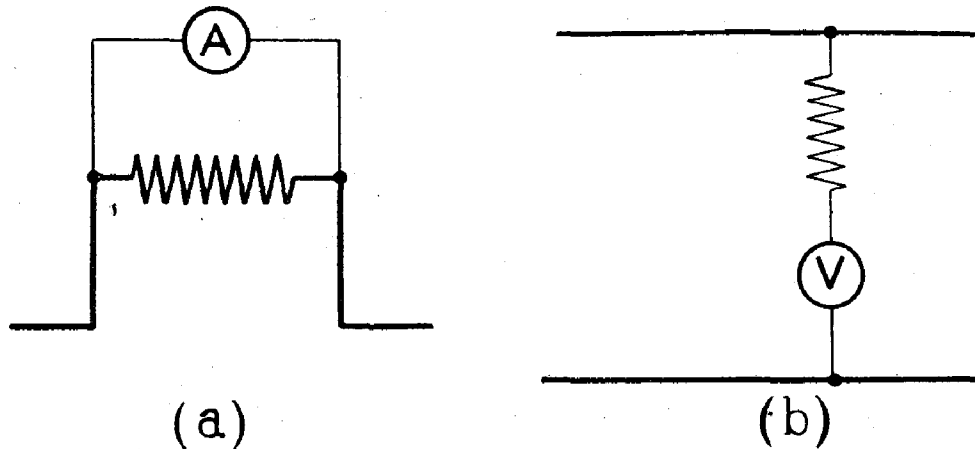

FIG. 6, CHAP. III.—Connection of instrument as ammeter or voltmeter.

A point of interest arises with regard to the power consumed by a voltmeter when used for the measurements of very high voltages, 1,000 volts and upwards. The moving coil instrument previously considered if used on a supply voltage of 1,000 volts, will consume 1,000 volts \times .01 ampere or 10 watts. In many instances this may be of the same order as the power supplied to the actual load, for example, an aircraft W/T transmitter may take only 90 watts, and the power consumed by the voltmeter is 10 per cent. of the total power supplied. If it is proposed to use a hot-wire instrument conditions are even worse, because it is difficult to design this form of instrument to give full-scale deflection with less than about .15 ampere; at 1,000 volts the voltmeter would then consume 150 watts which is nearly double that required by the transmitter. For this reason the hot-wire voltmeter is rarely used, the development of the electrostatic voltmeter from a laboratory instrument into a form suitable for service and commercial use having provided a much more efficient instrument.

The electrostatic voltmeter

11. The principle of electrostatic attraction cannot be applied to the measurement of current, but is frequently used for measurement of P.D. A typical instrument is shown in fig. 7. A light metal vane (A) is mounted on a pivoted spindle which also carries the pointer. This vane is free to move between two metal plates (B), which are electrically connected; for clarity only one of these plates is shown in the diagram. The moving vane is in metallic connection with the base plate via its controlling spring (not shown), while the plates (B) are insulated from it. When a P.D. is established between the moving vane and the fixed plates, the two systems acquire equal and opposite charges, and the resulting electrostatic attraction causes the vane to move into the space between the plates, and consequently a deflection of the pointer. This deflection is proportional to the square of the P.D. and the graduation of the scale is not uniform. The electrostatic voltmeter carries no current and consequently it consumes no power. It is more easily

and cheaply designed for high voltages—500 volts and above—than for low, and it is consequently used for the measurement of anode voltages in radio transmitters almost to the exclusion of other types.

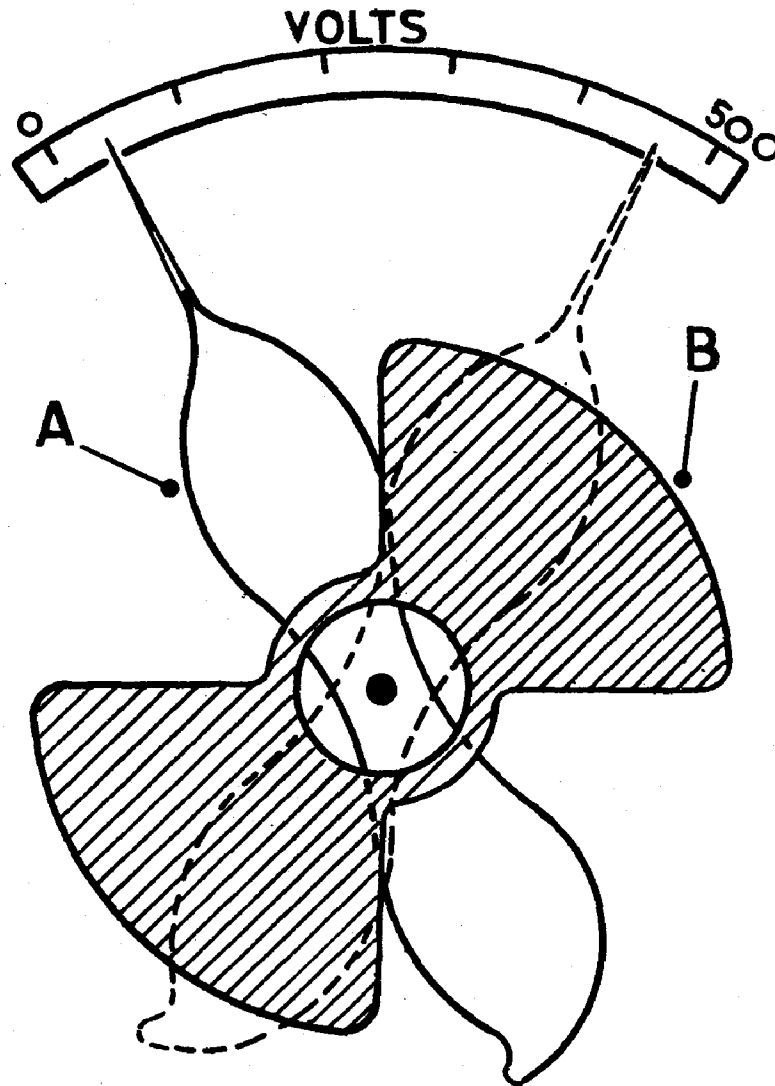

FIG. 7, CHAP. III.—Principle of electrostatic voltmeter.

The thermo-ammeter

12. This name is given in the service to an instrument which depends for its action upon the small E.M.F. which is generated when a junction of two dissimilar metals is heated, and is shewn in fig. 8. The junction is made by spot welding two very fine wires of dissimilar conducting materials at the point at which they make contact with a third wire which serves as a heating device. The thermo-electric couple, as it is called, frequently consists of copper and eureka or copper and constantan wires of about 50 s.w.g. The E.M.F. generated in the thermocouple causes a small current to flow, this current being measured by a low-reading moving coil milliammeter, and thus the complete thermo-ammeter consists of a moving coil milliammeter and thermocouple, the two parts being sometimes mounted separately, while in other designs the thermocouple forms an integral part of the instrument. These instruments are expensive in first cost and their repair entails highly-skilled workmanship. If it is necessary to make extempore

CHAPTER III.—PARA. 13

current measurements with an instrument of this type, great care must be exercised to ensure that the current-carrying capacity of the thermo-junction is not exceeded, for owing to the fineness of the wires they are incapable of withstanding even a small over-load. This principle is rarely if ever applied in measurement of voltage.

Measurement of resistance

13. The measurement of an unknown resistance by means of the Wheatstone's bridge has already been explained in Chapter I. It is often desirable, however, to make use of an instrument

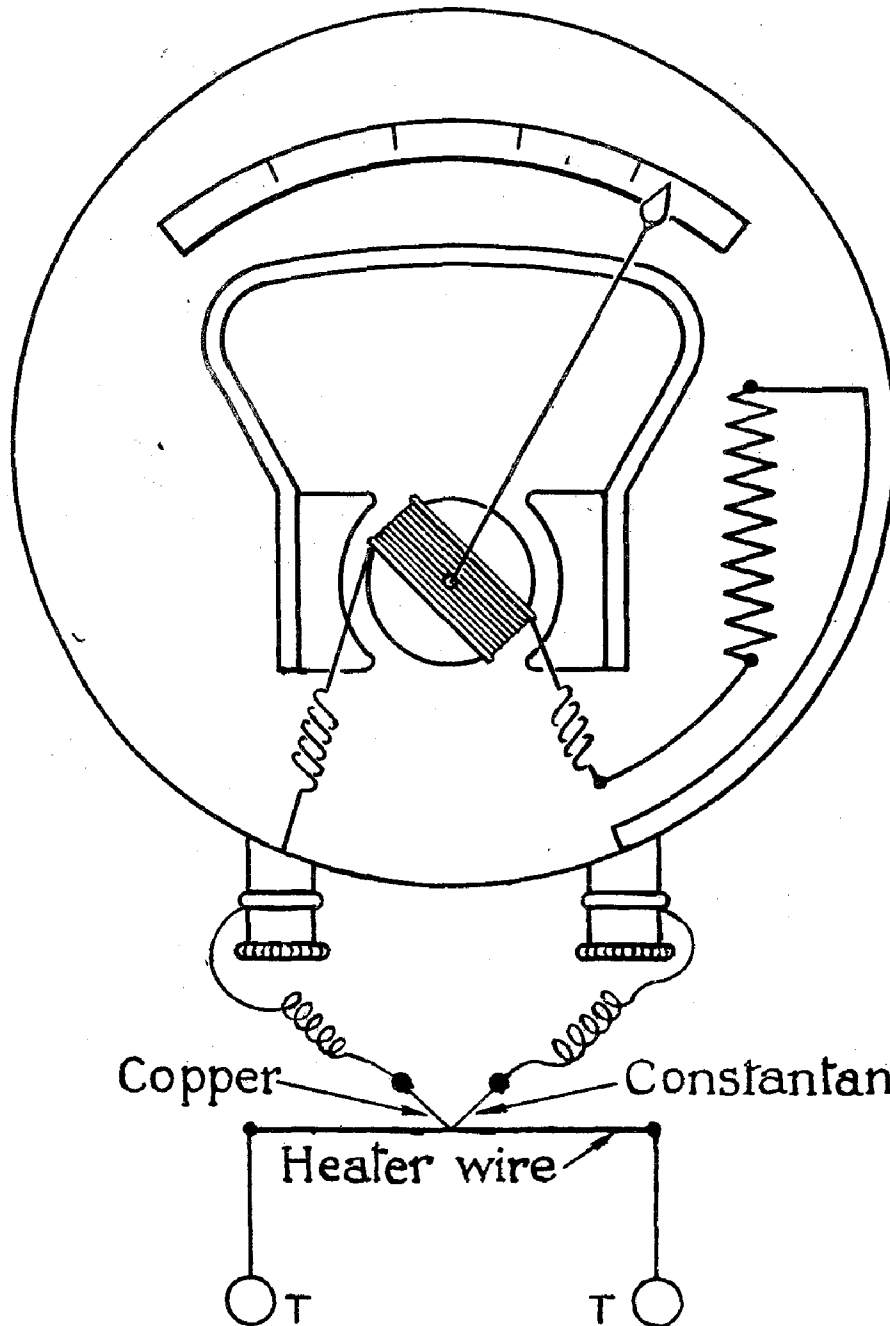

FIG. 8, CHAP. III.—Principle of thermo-ammeter.

which will rapidly determine the value of an unknown resistance, even at the expense of a high order of accuracy; it is preferable that the instrument used for this purpose should be portable, and should be direct reading, i.e. it should be equipped with a pointer and scale, giving the resistance of the circuit under measurement directly in ohms. Two types of instrument are in use for this purpose, the first consisting merely of a moving coil milliammeter in series with a small electric battery, which is usually made up of one or more dry cells and is fitted inside the case of the instrument. Assuming that the E.M.F. of the cell remains constant and its internal resistance negligible, the scale of the milliammeter may be calibrated in ohms instead of in milliamperes, since the resistance and current are in inverse proportion. This type of instrument is not suitable for the measurement of resistances below 1,000 ohms, and high accuracy of measurement of higher resistance cannot be expected. Its great advantage is that by suitable connections and internal arrangement it becomes a universal instrument reading several ranges of volts, amperes and ohms.

14. The true ohmmeter (fig. 9) consists of a special form of moving coil instrument, having a permanent magnet field in which a moving element is free to rotate through an angle of about 100 degrees. This moving element consists of two coils (C), (P), which are mounted at right angles to each other, current being carried to each coil by fine and extremely flexible leads, or by very

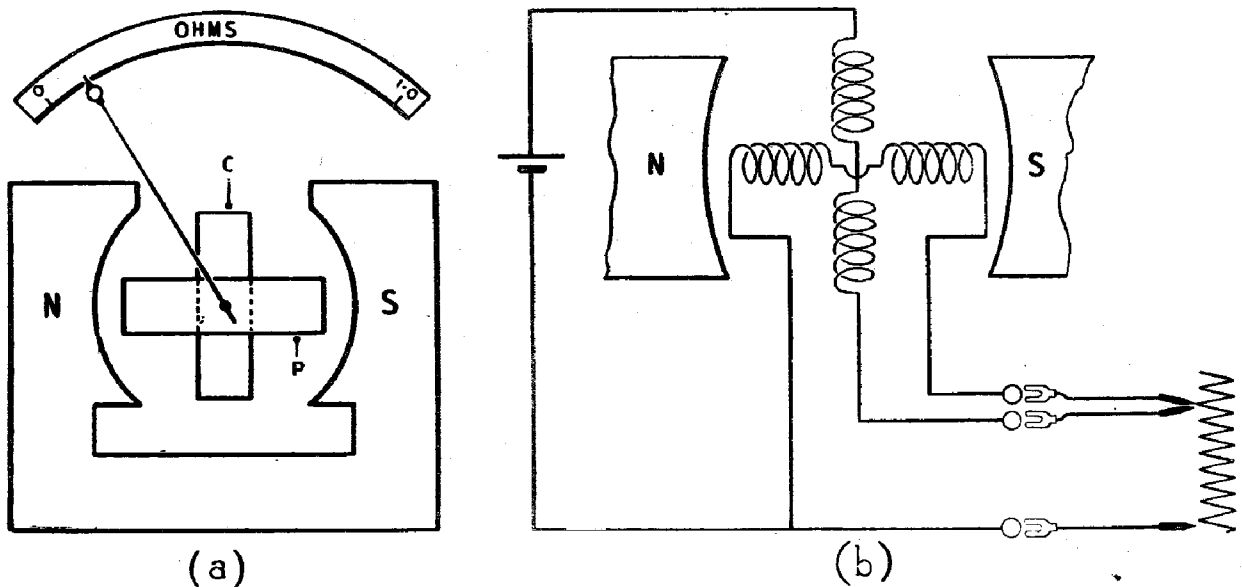

FIG. 9, CHAP. III.—Principle of ohmmeter.

weak springs so arranged that they exert no controlling torque upon the coils. The latter are therefore free, and when not in use the pointer carried by the moving element may rest at any point on the scale. It is important to realise that this is an essential feature of the instrument, and does not signify that it is defective. One of the coils, which is of low resistance and is called the current coil, is connected in series with a source of steady E.M.F. and by suitable leads and terminals to the resistance under test; thus the source of E.M.F., the current coil and resistance under test form a closed conductive circuit. The second coil, which is called the pressure coil, has a resistance which is large compared to the resistance under test, and is connected in parallel with the latter, so that the terminal P.D. of the pressure coil is the same as the voltage drop across the resistance. A typical circuit is given in fig. 9 which shows a type of ohmmeter suitable for the measurement of very low resistances, of the order of $\cdot 05$ ohms.

In this instrument the source of E.M.F. is a single secondary cell and the action is as follows. The current coil carries a current which is inversely proportional to the unknown resistance, while the pressure coil carries a current proportional to the P.D. between the ends of the

CHAPTER III.—PARAS. 15-17

resistance. The direction of the current through the two coils is such that the torque due to each is in opposition, thus a large current through the current coil tends to turn the coil so that the pointer reads zero, while if no current passes through the current coil, i.e. if the resistance under test is infinitely large, only the torque of the pressure coil is operative, and the pointer is deflected vigorously to the high reading end of the scale. For any value of resistance within the range of the scale, there is some position of equilibrium between the two opposing torques and the pointer comes to rest at a definite point on the scale, which can therefore be calibrated directly in ohms. It must be observed that this equilibrium position is not dependent upon the E.M.F. applied, because both the current coil torque and the pressure coil torque are varied to the same degree by a change in voltage.

15. For measurement of very high resistances, such as the insulation between an electric conductor and earth, the ohmmeter is of the same general form as the above, but the E.M.F. is necessarily higher, and may be 250 volts, 500 volts or in extreme cases 2,000 volts. It is then usual to use a source of supply consisting of a hand driven direct current generator which is often contained in the same casing as the ohmmeter proper and may derive its excitation (*see* Chapter IV) from the permanent magnetic field of the ohmmeter. In order to prevent excessive currents from flowing in the current coil in the event of the unknown resistance being abnormally low a protecting coil of the order of 100,000 ohms resistance is usually fitted in series with it. When the circuit under test has considerable capacitance, it is essential that the applied E.M.F. shall not fluctuate, otherwise the P.D. across the resistance will vary with the state of charge or discharge of the capacitance, and therefore it is preferable to arrange the generator drive through a slipping clutch, so that provided the speed of rotation exceeds a certain number of revolutions per minute, the generator speed remains constant. This arrangement is a feature of the "megger" testing set, but is not fitted in the "meg tester". When testing circuits of considerable capacitance with the latter instrument, care must be taken to maintain the generator speed as constant as possible.

POWER MEASUREMENT

16. An instrument which measures the power supplied to or delivered by any piece of apparatus is called a watt-meter. In direct current circuits the same information can be obtained by multiplying the current flowing through the device by the P.D. at its terminals, and as ammeters and voltmeters are generally fitted, this product is easily obtained and the watt-meter becomes redundant. In alternating current circuits, however, power is not as a rule equal merely to the product of volts and amperes, but also depends upon the amount of energy stored in the form of alternating magnetic and electric fields, and is equal to the product of volts and amperes further multiplied by a quantity called the power factor, the maximum value of which is unity and the minimum value zero. The more common forms of watt-meter will be described in Chapter V. Supply meters are used for the purpose of measuring the total energy supplied during a certain period. They are called integrating instruments, which means that they measure the average value of the energy supplied during a very short time and automatically register the sum of all these averages during the interval of operation. Supply meters may be divided into two main classes, viz. ampere-hour meters and watt-hour meters. Ampere-hour meters measure the quantity of electricity which passes, the energy supplied or consumed being derived by assuming that the P.D. remains constant, e.g. V volts. The meter measures the product of current and time, or $I \times t$, and this quantity further multiplied by the P.D. V , is the energy supplied in watt-hours. The dial may therefore be calibrated in watt-hours. Three principal types of ampere-hour meter have been developed, and a representative of each type will be described.

Electrolytic meters

17. A typical specimen is the Bastian meter, which depends for its action on the phenomenon of electrolysis of a very dilute solution of caustic soda. The electrolyte is contained in a glass vessel having a long neck of uniform bore. Two nickel electrodes are fitted in a compartment

made from an insulating material, and insulated leads from these electrodes are carried to the terminals of the instrument, to which the external circuit is connected. The whole of the supply current passes through the electrolyte, which is decomposed into its constituent gases hydrogen and oxygen. These gases escape into the air and the level of the liquid in the neck gradually sinks. The fall of the surface level is proportional to the number of coulombs which pass, and a scale which reads watt-hours, or kilowatt-hours (on the assumption of constant P.D.), is placed parallel to the neck, so that the level of the liquid gives the energy consumed in kilowatt-hours (B.O.T.U.). A thin film of oil on the surface of the liquid prevents evaporation of the electrolyte.

The advantages of the Bastian meter are its accuracy at low loads, owing to the absence of moving parts and consequent friction, its cheapness and simplicity. On the other hand, the gases evolved form an explosive mixture, and it is difficult to read while appreciable current is flowing owing to the formation of gas bubbles on the surface. The fact that a P.D. of about 2 volts occurs in the meter itself also causes it to be wasteful. Thus if a current of 50 amperes is flowing the power wasted in the meter itself is 100 watts or $\cdot 1$ kilowatt, hence 1 B.O.T.U. is consumed by the meter in 10,000 hours.

Commutator motor meters

18. This type of meter contains a member which rotates in the powerful magnetic field of a permanent magnet, fig. 10. This rotating member or armature is wound with wire but contains

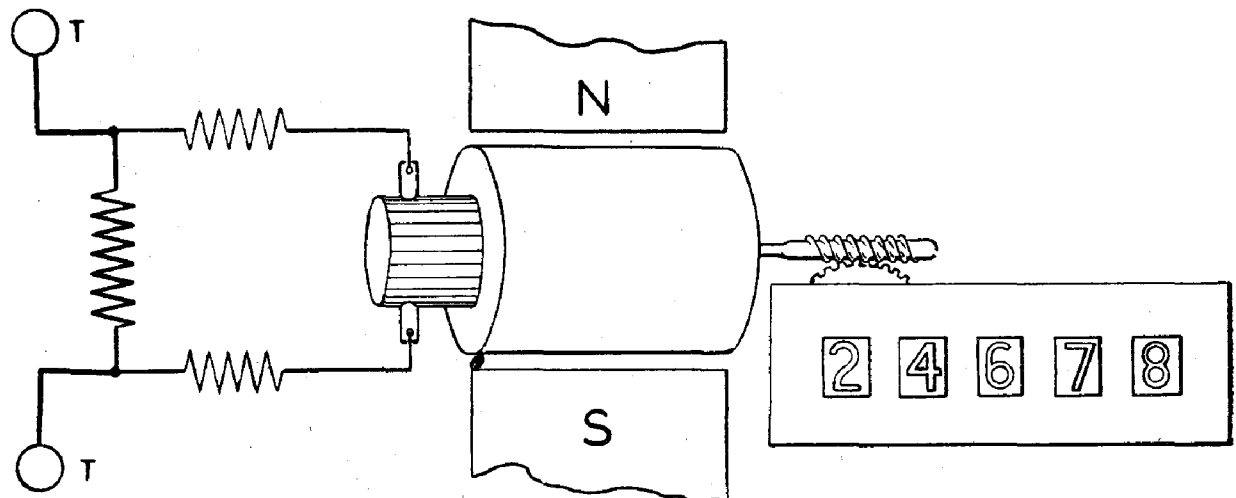

FIG. 10, CHAP. III.—Principle of commutator motor meter.

no iron-core, and is very light. It rotates on a hardened steel pivot in jewelled bearings, the steel spindle carrying the armature being extended at one end in order to carry a worm which engages with a worm wheel. The latter is the first of a train of wheels which form a register of the cyclometer type. The rotating armature is connected in series with a certain resistance, and carries only a definite fraction of the whole current, the remainder being carried by the shunt which forms an integral portion of the instrument. The reaction between this current and the permanent magnetic field in which the armature is situated causes rotation of the armature as described in the following chapter. Provided that the friction is negligible, the speed of rotation is directly proportional to the current flowing, and assuming that the applied P.D. is constant, the number of revolutions executed in a given time is directly proportional to the energy supplied. The cyclometer dials are therefore directly calibrated in B.O.T.U.

Mercury motor meters

19. In this type the rotating member consists of a disc of copper, the poles of the permanent magnet which provides the magnetic field being situated in such a position as to embrace only

CHAPTER III.—PARA. 19

a sector of the disc, as illustrated in fig. 11. The disc rotates about a vertical pivot in jewelled bearings, a worm and worm wheel being used to convey the rotation to the counter mechanism as in the previous type described. The chamber (B) surrounding the disc is of insulating material and is filled with mercury, (A). Current is led into the mercury by suitable connections, passing through the copper disc and out by the lower bearing of the spindle, the jewel bearing of which is suitably arranged for this purpose. The direction of current in the disc is approximately radial, and application of the left-hand rule will give the direction in which the disc tends to rotate, while eddy currents induced in the disc owing to its rotation (the direction

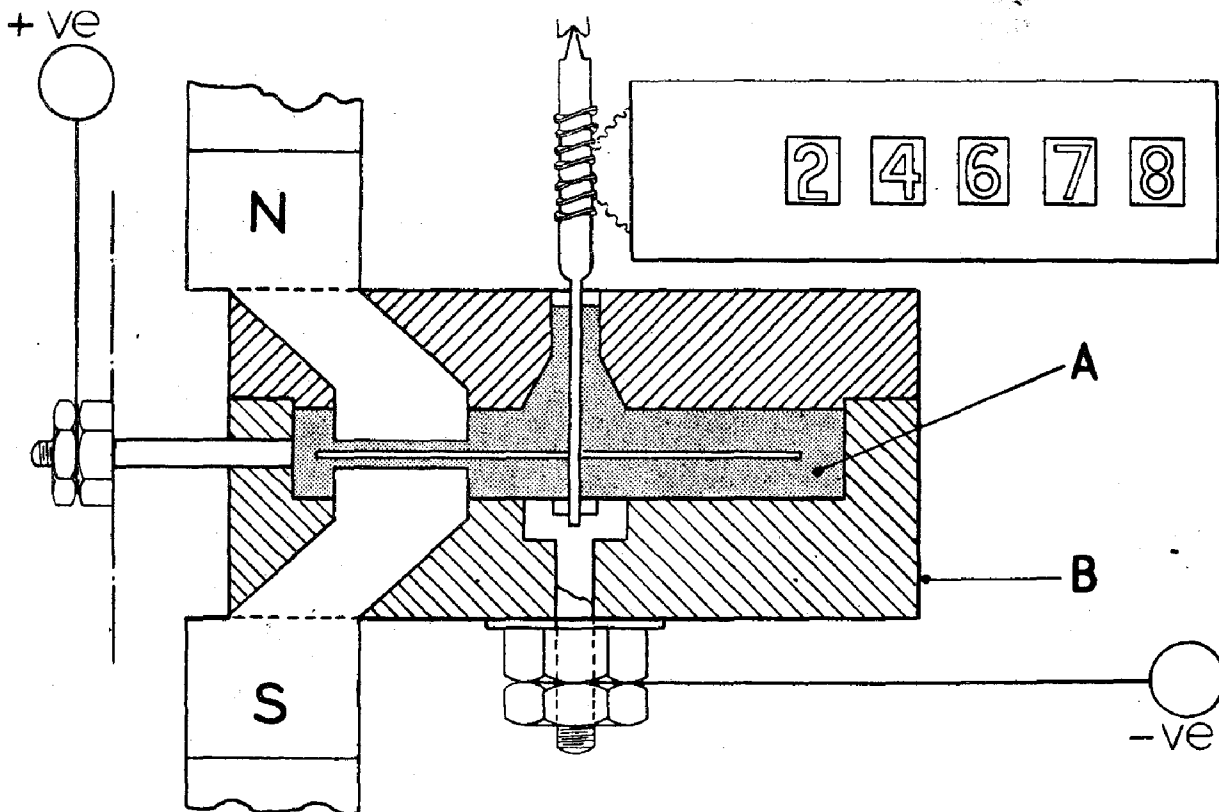

FIG. 11, CHAP. III.—Principle of mercury motor meter.

of which can be found by the right-hand rule) tend to retard the motion. The result of the combined phenomena is that the disc rotates at a speed which is directly proportional to the current flowing, and with constant P.D. this is proportional to the power supplied at any instant. Over a period of time the number of revolutions, as indicated by the cyclometer, is proportional to the number of B.O.T.U. which have passed during the period, and the dials are graduated directly in B.O.T.U.

True energy or watt-hour meters are not often used for D.C. supply, except at central power stations where the total output current is very large, and it is not necessary to describe them here. Such types of watt-hour meter as are likely to be met with in the service are described in Chapter V.

This file was downloaded
from the RTFM Library.

Link: www.scottbouch.com/rtfm

Please see site for usage terms,
and more aircraft documents.

