

## CHAPTER IV.—DYNAMO-ELECTRIC MACHINERY

### Introductory

1. In Chapter I it was stated that an electromotive force may be produced by any one of four methods, namely, chemical, thermal, frictional or electro-magnetic. Of these, the only one which lends itself to the conversion of mechanical into electrical energy on a large scale is the latter, and it is now proposed to discuss the means by which this conversion is achieved. We have seen that whenever relative motion takes place between a conductor and a magnetic field, the change of flux-linkage with the conductor results in the production of an E.M.F. The form of relative motion which is most readily adapted to this end is the rotation, either of a conductor in a stationary magnetic field, or of a magnetic field in the neighbourhood of a stationary conductor. The simplest instance is provided by the rotation of a closed conductive loop in a uniform field, which results in the production of an alternating E.M.F. Before proceeding further it is necessary to introduce certain definitions used in connection with alternating quantities.

### Definitions

2. An alternating quantity may be briefly defined as one which periodically reverses its direction. Such quantities possess three characteristics by which they may be completely described. They are :—

- (i) Frequency.
- (ii) Wave form.
- (iii) Amplitude or peak value.

In order to define these characteristics let the alternating quantity be an electromotive force acting in an electric circuit. At a given instant the E.M.F. may be supposed to be zero and this instant will be called zero time. After 0·001 second, the E.M.F. may have a value of 50 volts acting in a certain direction in the circuit, after 0·002 second, a value of 95 volts in the same direction, and so on through a series of values first increasing and then decreasing, again reaching zero value after 0·005 seconds. The E.M.F. then commences to grow in magnitude but in the opposite direction, passing through a series of values as before until it reaches again zero value. The complete series of values takes 0·01 seconds to perform, and the variation is then repeated again and again for some indefinite period. An E.M.F. of this nature is plotted on a time scale in fig. 1. The value of an alternating quantity at any given instant is called its *instantaneous*

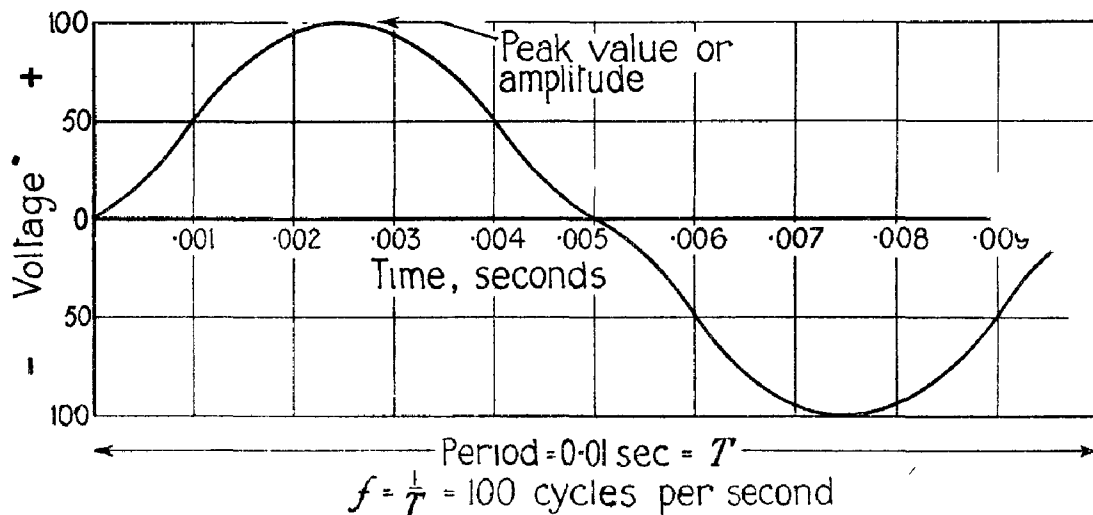

FIG. 1, CHAP. IV.—Graphical representation of an alternating E.M.F.

## CHAPTER IV.—PARA. 3

*value.* A complete series of values, both positive and negative, is called one *cycle*. The time taken for the execution of one cycle is called the *period* or *periodic* time, and is denoted by the symbol  $T$ . In the example given above the periodic time is 0.01 second. The *frequency* is the number of cycles completed in one second and is denoted by the symbol  $f$ ; since in the above instance, one cycle is performed in 0.01 seconds, there will be  $\frac{1}{0.01}$  or 100 cycles per second. The frequency and the periodic time are thus related by the equation  $f = \frac{1}{T}$ . The shape of the curve showing the variation of instantaneous value with time is called the *wave form*, and the *amplitude* or *peak value* is the maximum value reached during each half cycle.

### Production of an alternating E.M.F.

3. Consider a closed loop P, Q, capable of rotation about an axis X, X', in a uniform field produced by the magnetic poles N, S, fig. 2. This arrangement is shown in cross-section in the following diagram (fig. 3), the two horizontal members of the loop being indicated by circles. The instant when the loop is in the neutral plane between the poles will be taken as zero time, and it will be assumed to rotate in a clockwise direction. At the instant when rotation commences, then, the loop is moving in such a direction that the change of flux linking with it is zero, and no

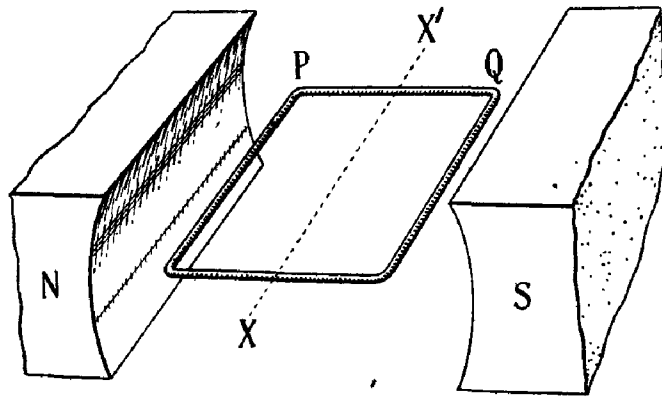

FIG. 2, CHAP. IV.—Closed loop in magnetic field.

E.M.F. is induced, although it will be observed that maximum flux is enclosed at this moment (fig. 3a). After a short interval of time, the loop will reach the position shown in fig. 3b, having turned through an angle of  $30^\circ$ . The conductor P is moving downward, while the conductor Q is moving upward, and the number of tubes of flux linking with the loop is decreasing. An E.M.F. is, therefore, induced in each conductor; its direction may be found by the right hand rule, and is indicated in the conventional manner in the diagram. By Faraday's law the magnitude of the E.M.F. will be proportional to the rate at which the flux-linkage with the loop is changing. In fig. 3c the loop has rotated through  $90^\circ$  from its original position, and no flux whatever is linking with the loop. At first sight it might appear that no E.M.F. will be induced in this position, but this is not so, for actually the flux is in process of complete reversal in direction at this instant, and it will be seen later that the maximum E.M.F. will be generated when the loop is passing through this position. As rotation continues the loop eventually reaches the position indicated in fig. 3d. At this instant the two sides of the loop are moving in a direction parallel to the magnetic flux, and no change of flux-linkage takes place, hence the induced E.M.F. is zero. During the succeeding semi-rotation, the conductor P is moving upward while the conductor Q is moving downward through the magnetic field and the direction of the induced E.M.F. is reversed in each. Maximum induction will again take place when the loop is passing through the position shown in fig. 3e, and finally, after one complete revolution, the loop regains its original position

in which the induced E.M.F. is again zero (fig. 3f). The rotation of the loop through one complete revolution of  $360^\circ$  has thus resulted in the production of a single cycle of alternating E.M.F., and so long as the rotation is continued the foregoing process will be repeated.

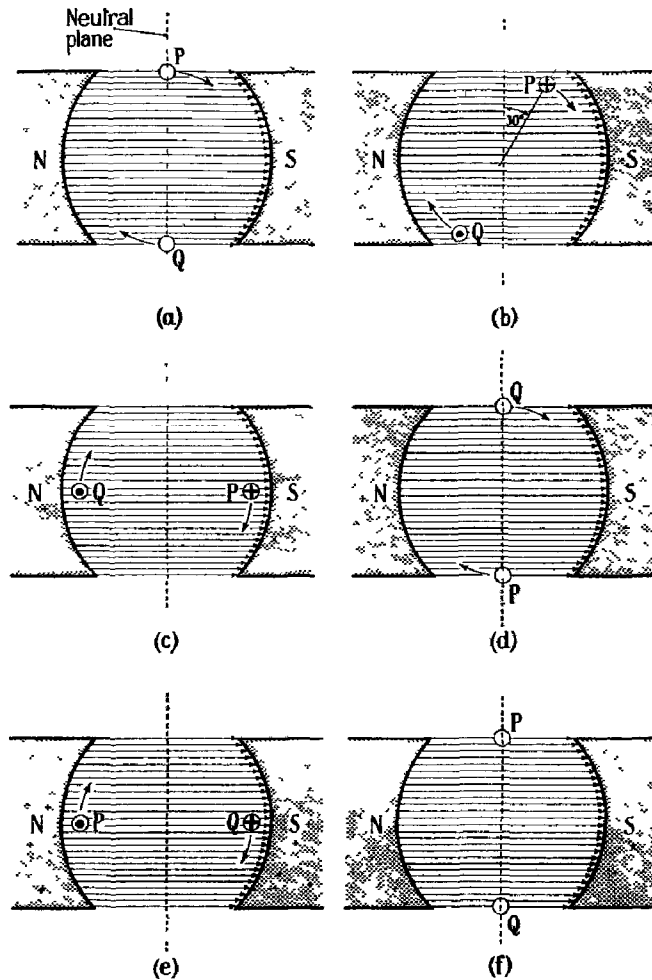

FIG. 3, CHAP. IV.—Production of alternating E.M.F.

**Sine law**

4. In order to establish an expression giving the E.M.F. induced in the loop throughout its rotation, certain results obtained in Chapter II must be recalled. It was there stated that if a conductor of length  $l$  centimetres is moved with a uniform velocity of  $U$  centimetres per second through a uniform magnetic field of density  $B$  tubes per square centimetre (gauss), the E.M.F. induced is

$$e = BIU \times 10^{-8} \text{ volts.}$$

In the present instance, the conductors are assumed to rotate with constant velocity in space, but the relative motion between conductor and flux depends upon the angle at which the loop is moving through the flux at every instant throughout the revolution. The induced E.M.F. at any instant is proportional to the sine of the angle through which the loop has turned, measured from its initial position in the neutral plane. This may be shown by the aid of fig. 4 in which the magnetic field and the loop PQ have been re-drawn. At the instant depicted, the loop has turned through an angle  $\theta$  from its initial position, and the direction of motion of the conductor P

## CHAPTER IV.—PARA. 7

velocity and is denoted by the greek letter  $\omega$  (omega). After an interval of  $t$  seconds from the commencement of rotation, the loop has rotated through an angle of  $\omega t$  radians, and the E.M.F. at this instant is

$$\begin{aligned} e &= 2 B l U \sin \omega t \\ &= \mathcal{E} \sin \omega t. \end{aligned}$$

*Example.*

A loop of wire two feet square rotates in a uniform magnetic field having a density of 1,000 gauss, at a speed of 600 r.p.m., commencing from a position in the neutral plane. Find the peak value of the induced E.M.F. and the instantaneous value (i) 0.015 seconds and (ii) 1.56 seconds from the commencement of rotation.

Each side of the loop passes round the circumference of a circle 2 feet in diameter, in  $\frac{1}{300}$  minute or 0.1 second. The linear velocity of each is therefore

$$\begin{aligned} U &= \frac{\pi d}{0.1 \text{ sec.}} = \frac{\pi \times 2 \times 30.48 \text{ cm.}}{0.1 \text{ sec.}} \\ &= 1940 \frac{\text{cm.}}{\text{sec.}} \\ \mathcal{E} &= 2 B l U \times 10^{-8} \\ &= 2 \times 1000 \times 2 \times 30.48 \times 1940 \times 10^{-8} \\ &= 2.34 \text{ volts.} \end{aligned}$$

The time taken to execute one complete cycle of E.M.F. is 0.1 second and the frequency is  $f = \frac{1}{T} = 10$  cycles per second. The angular velocity is therefore  $2\pi \times 10$  radians per second.

After rotation for 0.015 second the E.M.F. will be

$$\begin{aligned} e &= 2.34 \sin (62.8 \times 0.015) \\ &= 2.34 \sin 0.3\pi \\ &= 2.34 \sin 0.942. \end{aligned}$$

7. It is now necessary to find the numerical value of  $\sin 0.942$ . To do this, convert 0.942 radians to circular measure by the relation already given, i.e.

$$0.942 \text{ radians} = 0.3\pi \text{ radians} = 0.3\pi \times \frac{180}{\pi} \text{ degrees};$$

or  $0.942 \text{ radians} = 54 \text{ degrees.}$

From trigonometrical tables,  $\sin 54^\circ = 0.8090$

$$\begin{aligned} \therefore e &= 2.34 \times 0.8090 \\ &= 1.9 \text{ volts, approximately.} \end{aligned}$$

After 1.56 seconds, the loop has rotated through an angle of  $\omega t$  radians, where

$$\omega t = 2\pi \times 10 \times 1.56 \text{ or } 31.2\pi \text{ radians.}$$

$$\begin{aligned} 31.2\pi \text{ radians} &= \frac{31.2\pi \times 180}{\pi} \text{ degrees} \\ &= 5616 \text{ degrees.} \end{aligned}$$

The loop has therefore executed  $\frac{5616}{360}$  or 15.6 revolutions. Since after 15 revolutions the loop is

in the neutral plane, we are only concerned with the E.M.F. developed after the ensuing 0.6 of a revolution, i.e. after  $0.6 \times 360 = 216$  degrees of rotation from the time at which the loop last

## CHAPTER IV.—PARA. 5

is shown by the line  $RP$ , the length of which may represent the velocity  $U$  of the conductor to any convenient scale. The velocity  $RP$  may be resolved into two component velocities which are mutually perpendicular, first the component  $RS$  which is parallel to the magnetic field; motion in this direction results in no change of flux-linkage and consequently this component of the velocity cannot be responsible for the production of an E.M.F.: second, the component  $SP$  which is perpendicular to the flux; motion in this direction results in a change of flux-linkage, and the induced E.M.F. is proportional to the magnitude of this component of the velocity.

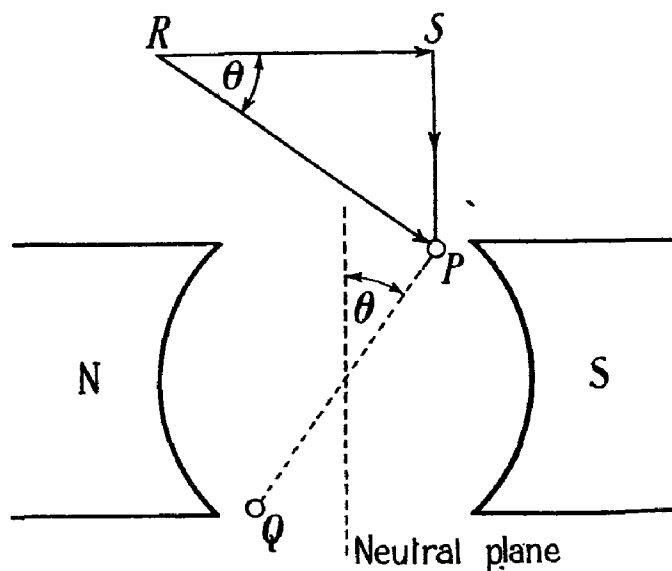

FIG. 4, CHAP. IV.—Components of velocity of P relative to direction of field.

Since  $RS$  is perpendicular to the initial plane of the loop and  $RP$  is perpendicular to the loop when it has turned through the angle  $\theta$ , it follows that the angle  $SRP$  is also equal to  $\theta$ , and  $SP = RP \sin \theta$ ; the instantaneous E.M.F. developed in the conductor  $P$  is therefore proportional to  $RP \sin \theta$ , and will reach a maximum when  $\theta = 90^\circ$ ,  $\sin \theta = 1$ . At this instant the induced E.M.F. is equal to  $BIU \times 10^{-8}$  volts, and therefore, if  $e_p$  is the E.M.F. induced at any instant in the conductor  $P$ ,

$$e_p = BIU \sin \theta \times 10^{-8} \text{ volts.}$$

In a similar manner, it is found that the E.M.F. induced in the conductor  $Q$  at any instant is

$$e_q = BIU \sin \theta \times 10^{-8} \text{ volts,}$$

and the total induced E.M.F. is

$$e = e_p + e_q = 2 BIU \sin \theta \times 10^{-8} \text{ volts.}$$

The maximum or peak value  $\mathcal{E}$  of the induced E.M.F. is  $2 BIU \times 10^{-8}$  volts, and the preceding equation may be written

$$e = \mathcal{E} \sin \theta$$

where

$$\mathcal{E} = 2 BIU \times 10^{-8}$$

### Sine curve

5. Having established the manner in which the induced E.M.F. varies from instant to instant during the rotation of the loop, it can be seen from fig. 4 that if we allow  $RP$  to represent the peak value  $\mathcal{E}$  of the induced E.M.F. to any convenient scale, the line  $SP$  represents the instantaneous value. This forms the basis of a convenient method of plotting a curve showing the instantaneous value of the E.M.F. for all values of the angle  $\theta$ . In fig. 5, the line  $OP$  is assumed

to rotate about the point O in a counter-clockwise direction, its length representing the peak value of the E.M.F. to any convenient scale. A horizontal line is drawn through the centre of rotation, O, and upon this a scale of degrees of rotation is set up. As the vertical line PS is equal to  $OP \sin \theta$ , it represents to scale the instantaneous E.M.F.  $e = \mathcal{E} \sin \theta$ . An ordinate of length PS is therefore erected on the scale of degrees, having the value of the angle  $\theta$  as abscissa. The procedure is shown for a particular value of  $\theta$ , while the dotted lines indicate the manner in which other points are obtained. When the point P lies above the horizontal through the centre of rotation O, the instantaneous E.M.F. is plotted as a positive quantity, i.e.  $e$  is regarded as positive for values of between  $0^\circ$  and  $180^\circ$ , while for values between  $180^\circ$  and  $360^\circ$ ,  $e$  is regarded as of negative sign.

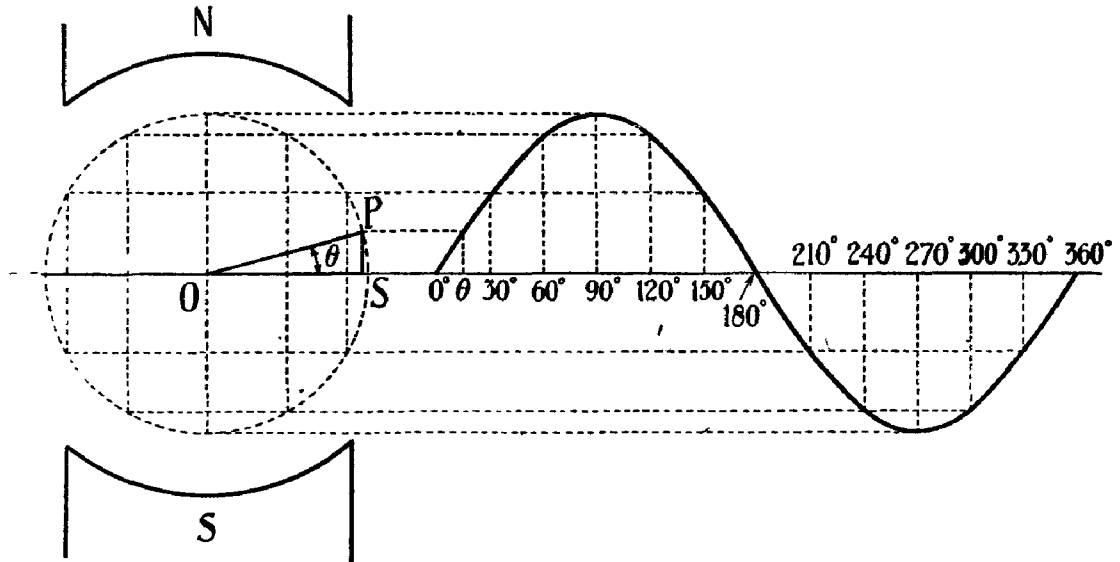

FIG. 5, CHAP. IV.—Sinusoidal E.M.F.

The curve drawn through all the points so obtained is called a sine curve, and an E.M.F. which varies in this way is said to be sinusoidal. This is the simplest wave form which an alternating quantity may assume, and is very nearly approached in a well-designed source of alternating E.M.F. For this reason, it is usually assumed that an alternating E.M.F. is sinusoidal, unless the contrary is distinctly stated.

**Angular velocity**

6. It is convenient to express the angle  $\theta$  in such a way that the instantaneous value is made to depend upon time, rather than the angle through which the loop has turned. To do this, it is first necessary to express the angle in radians instead of degrees. A radian is the angle at the centre of a circle subtended by an arc equal in length to the radius of the circle, and is the trigonometrical unit of angular measurement. The circumference of a circle contains 360 degrees, and its length is  $2\pi$  times its radius, so that a rotation through  $360^\circ$  is the same as rotation through  $2\pi$  radians.

Hence  $360 \text{ degrees} = 2\pi \text{ radians}$

$$1 \text{ degree} = \frac{2\pi}{360} \text{ radians}$$

$$n \text{ degrees} = \frac{n \times \pi}{180} \text{ radians}$$

In performing one revolution, then, the loop passes through an angle of  $2\pi$  radians. If it rotates at  $f$  revolutions per second, it passes through  $2\pi f$  radians per second. This is called its angular

## CHAPTER IV.—PARA. 7

velocity and is denoted by the greek letter  $\omega$  (omega). After an interval of  $t$  seconds from the commencement of rotation, the loop has rotated through an angle of  $\omega t$  radians, and the E.M.F. at this instant is

$$\begin{aligned} e &= 2 B l U \sin \omega t \\ &= \mathcal{E} \sin \omega t. \end{aligned}$$

*Example.*

A loop of wire two feet square rotates in a uniform magnetic field having a density of 1,000 gauss, at a speed of 600 r.p.m., commencing from a position in the neutral plane. Find the peak value of the induced E.M.F. and the instantaneous value (i) 0.015 seconds and (ii) 1.56 seconds from the commencement of rotation.

Each side of the loop passes round the circumference of a circle 2 feet in diameter, in  $\frac{1}{300}$  minute or 0.1 second. The linear velocity of each is therefore

$$\begin{aligned} U &= \frac{\pi d}{0.1 \text{ sec.}} = \frac{\pi \times 2 \times 30.48 \text{ cm.}}{0.1 \text{ sec.}} \\ &= 1940 \frac{\text{cm.}}{\text{sec.}} \\ \mathcal{E} &= 2 B l U \times 10^{-8} \\ &= 2 \times 1000 \times 2 \times 30.48 \times 1940 \times 10^{-8} \\ &= 2.34 \text{ volts.} \end{aligned}$$

The time taken to execute one complete cycle of E.M.F. is 0.1 second and the frequency is  $f = \frac{1}{T} = 10$  cycles per second. The angular velocity is therefore  $2\pi \times 10$  radians per second.

After rotation for 0.015 second the E.M.F. will be

$$\begin{aligned} e &= 2.34 \sin (62.8 \times 0.015) \\ &= 2.34 \sin 0.3\pi \\ &= 2.34 \sin 0.942. \end{aligned}$$

7. It is now necessary to find the numerical value of  $\sin 0.942$ . To do this, convert 0.942 radians to circular measure by the relation already given, i.e.

$$0.942 \text{ radians} = 0.3\pi \text{ radians} = 0.3\pi \times \frac{180}{\pi} \text{ degrees};$$

or  $0.942 \text{ radians} = 54 \text{ degrees.}$

From trigonometrical tables,  $\sin 54^\circ = 0.8090$

$$\begin{aligned} \therefore e &= 2.34 \times 0.8090 \\ &= 1.9 \text{ volts, approximately.} \end{aligned}$$

After 1.56 seconds, the loop has rotated through an angle of  $\omega t$  radians, where

$$\omega t = 2\pi \times 10 \times 1.56 \text{ or } 31.2\pi \text{ radians.}$$

$$\begin{aligned} 31.2\pi \text{ radians} &= \frac{31.2\pi \times 180}{\pi} \text{ degrees} \\ &= 5616 \text{ degrees.} \end{aligned}$$

The loop has therefore executed  $\frac{5616}{360}$  or 15.6 revolutions. Since after 15 revolutions the loop is

in the neutral plane, we are only concerned with the E.M.F. developed after the ensuing 0.6 of a revolution, i.e. after  $0.6 \times 360 = 216$  degrees of rotation from the time at which the loop last

passed through the neutral plane. Trigonometrical tables give the values of  $\sin \theta$  for angles between  $0^\circ$  and  $90^\circ$  only, but fig. 5 shows that, for angles between  $90^\circ$  and  $180^\circ$ ,  $\sin \theta = \sin (180^\circ - \theta)$ . Similarly, for angles between  $180^\circ$  and  $270^\circ$ ,  $\sin \theta = -\sin (\theta - 180^\circ)$  and for angles between  $270^\circ$  and  $360^\circ$ ,  $\sin \theta = -\sin (360^\circ - \theta)$ . For example, the instantaneous E.M.F. after rotation through  $210^\circ$  is of the same magnitude as after rotation through  $30^\circ$ , but is acting in the opposite direction round the loop. Mathematically, this is expressed by writing

$$\sin 210^\circ = -\sin 30^\circ$$

After 1.56 seconds, then, the instantaneous E.M.F.,  $e$ , is  $2.34 \sin 216^\circ$  and  $\sin 216^\circ = -\sin 36^\circ$ . As  $\sin 36^\circ = .5878$ ,

$$\begin{aligned} e &= -2.34 \times .5878 \\ &= -1.375 \text{ volts.} \end{aligned}$$

8. As the loop forms a complete conductive circuit, a conduction current will be established in it by the alternating E.M.F. The current will also be an alternating quantity, having the same frequency as the E.M.F. By means of devices to be described later, the current is led to an external circuit, where it can perform useful work. The magnitude of the current depends on the opposition offered by the conductor, which is never less, but may be considerably greater than the resistance of the circuit, and is called its impedance. The factors governing the magnitude of the impedance, and the resulting relations between current and voltage in an A.C. circuit are dealt with in Chapter V. The simple arrangement of relative motion between a magnetic field and a conductor described above is prototype of all kinds of dynamo-electric machinery, but many modifications are necessary in order to produce a machine of practical utility some of which are of general application to all types and others peculiar to the particular function which the machine is designed to perform.

### Frequency

9. In the arrangement shown in figs. 2 and 3, a complete cycle of E.M.F. is generated by every revolution of the loop. The frequency is therefore equal to the number of revolutions per second. Suppose now that the magnetic field is maintained by two pairs of poles, arranged alternately as shown in fig. 6. One complete cycle of E.M.F. will then be generated in a conductor

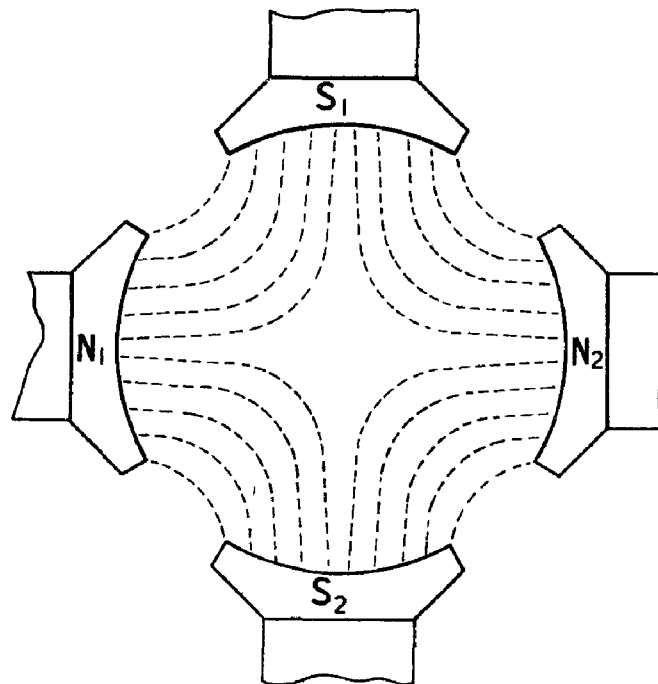

FIG. 6, CHAP. IV.—Four-pole field.

## CHAPTER IV.—PARA. 10

passing from  $N_1$  to  $N_2$ , and another cycle in passing from  $N_2$  to  $N_1$ , so that with two pairs of poles two complete cycles are executed in a single rotation of the loop. In general if there are  $p$  pairs of poles there will be  $p$  cycles per revolution, and the frequency is given by the equation

$$f = p \times \text{number of revolutions per second.}$$

For example, if a twelve-pole machine is required to give 180 cycles per second, it must rotate at  $\frac{180}{6} = 30$  revolutions per second or 1,800 r.p.m. With one pair of poles, then, one complete cycle is obtained in 360 degrees of rotation. With a four-pole field one cycle is obtained in 180 degrees of rotation, but the resulting E.M.F. passes through the same variation as with the two-pole arrangement, except that two complete cycles are executed in one revolution. This leads to the conception of "electrical" as opposed to "geometrical" degrees. Each conductor is said to pass through 360 electrical degrees in the space through which a complete cycle of E.M.F. is generated. One complete revolution, in a four-pole field, corresponds to  $720^\circ$ , in an eight-pole field  $1,440^\circ$  and so on.

### The field magnets and armature

10. Permanent magnets are unsuitable for the production of the powerful field which is generally desirable in alternating current generators, being expensive to manufacture in large sizes, easily damaged by rough treatment, and liable to become demagnetized by the action of the current in the armature winding. The field is, therefore, generally produced by an electro-magnetic system consisting of a cast steel yoke of cylindrical form which forms the carcass of the whole machine, and upon which are radially mounted soft iron pole-pieces which project inwards as shown in fig. 7. Each pole-piece carries a magnetizing winding supplied with current

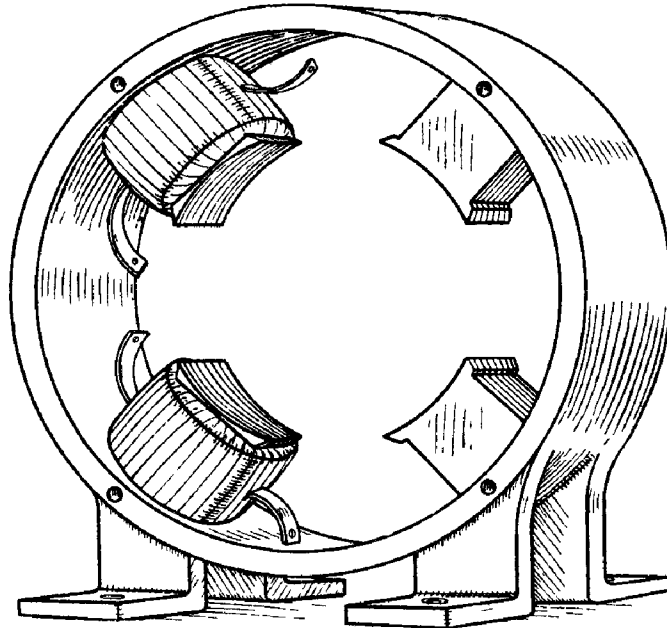

FIG. 7, CHAP. IV.—Carcass with pole pieces and field winding.

from some external source ; two of these coils are shown in position. A further advantage of an electro-magnetic field is the ease with which the flux density can be varied. It will be remembered that the amplitude of the E.M.F. depends directly upon the flux density and speed of rotation. As variation of the speed of rotation varies both the magnitude of the E.M.F. and the frequency, and the latter is generally required to be constant, it is necessary to control the magnitude of the E.M.F. not by speed control but by variation of the flux density. This is easily arranged by means of a resistance in series with the field magnet winding, which controls the magnetizing current and therefore the magnetic field strength ; this control is termed a field regulator.

11. In order to produce an appreciable electromotive force in the rotating loop it is desirable that the flux density of the field shall be as high as possible. This can be achieved by reducing the reluctance of the magnetic circuit, and to do this the air gap in the magnetic field must be reduced to a minimum compatible with free rotation of the loop. In practice the conductors in which the E.M.F. is to be induced may be wound on an iron core of cylindrical form, and the field magnets so shaped as to embrace this core as closely as possible. The conductors are then either wound in longitudinal slots cut in the periphery of the core parallel to the shaft upon which it is mounted, or are pushed through tunnels drilled through the core near and parallel to the surface. The whole assembly including the shaft, core and winding, is termed the armature, and the two types of winding are referred to as slot-winding and tunnel-winding respectively.

### Eddy currents

12. The introduction of the iron core gives rise to a new problem. Its rotation in the magnetic field produces varying electromotive forces in the core itself, and since it is of conducting material, currents are set up which circulate in ever-changing paths in the iron, as in fig. 8a.

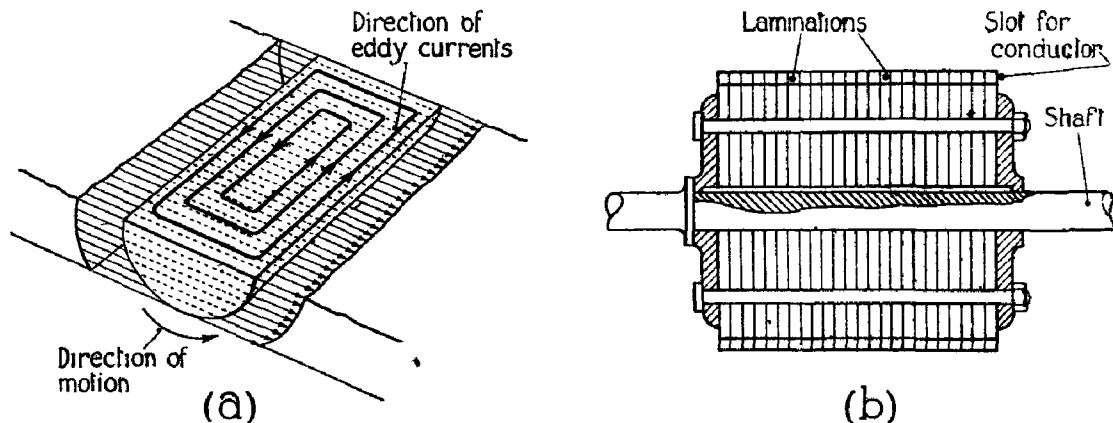

FIG. 8, CHAP. IV.—(a) Eddy currents. (b) Laminated armature.

These are called eddy currents, and represent a wastage of energy in the form of heat, which is doubly undesirable inasmuch as the heating of the core results in heating of the conductors with a consequent increase in resistance. Eddy currents can never be entirely eliminated, but can be reduced considerably by increasing the resistance of the paths in which they flow. The desired end is attained by building up the core from thin circular plates of soft iron called armature stampings, each stamping being insulated from those adjacent by thin paper, varnish, or the natural mill-scale of the plates. This type of construction is known as lamination, and the core is described as a laminated iron core (fig. 8b). The actual conductor may consist of a single loop or a number of complete turns in series with a resulting increase in the amplitude of the generated E.M.F. Of any complete loop or turn of wire in the winding, only those portions which move transversely across the flux are instrumental in generating E.M.F. and these portions are referred to as "inductors". The portions not contributing to the E.M.F. are called end connectors, or coil sides, according to the type of winding. The production of an E.M.F. in a wound armature is illustrated in fig. 9, in which, for clearness, only a single pair of field poles is shown. In the position shown in fig. 9a the inductors (shown by circles) are in the neutral plane and no E.M.F. is being generated. As the armature rotates in a counter-clockwise direction the inductors move in such a manner that a change occurs in the flux linking with each complete turn of the winding. In fig. 9b the armature has moved through 30 electrical degrees, the direction of the E.M.F. is as shown by the conventional signs and its magnitude is  $\mathcal{E} \sin 30^\circ$ . After rotation through 90 electrical degrees (fig. 9c) the inductors are situated directly under the centres of the field poles; at this instant the flux is undergoing a reversal of direction through the loop and the E.M.F. reaches its maximum value. In the position shown in fig. 9d, i.e. after rotation through 120°,

## CHAPTER IV.—PARAS. 13-14

the E.M.F. is still in the same direction, but its magnitude is decreasing, while in fig. 9e the inductors are once more in the neutral plane and the E.M.F. is zero. In fig. 9f the armature has turned through a further  $30^\circ$ , making  $210^\circ$  in all, and the direction of E.M.F. is now reversed, while further rotation, until the inductors are once more in the neutral plane, will complete one cycle of E.M.F.

### Slip rings

13. In fig. 9 the external circuit is shown as if it were directly connected to the armature winding, which is not practicable owing to its rotation. In the single-phase alternator each end of the whole winding is connected to one of a pair of slip rings, which are of brass or bronze and are shrunk on to the shaft over mica or micanite insulation (fig. 10). The rings are insulated from each other by mica or fibre washers. The external circuit is then connected to the winding by brushes, which are of hard carbon, graphitic carbon or copper gauze, the material depending to some extent upon the speed of rotation. The brushes are held in light but firm contact with the rings by metal springs.

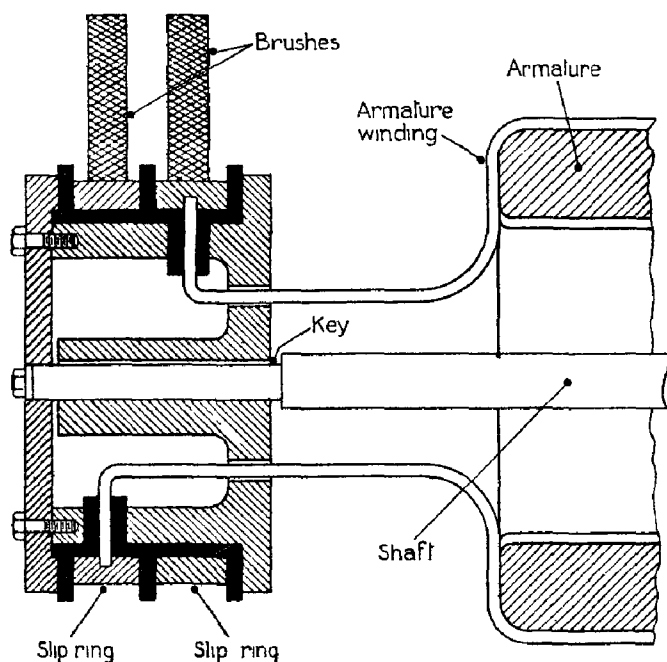
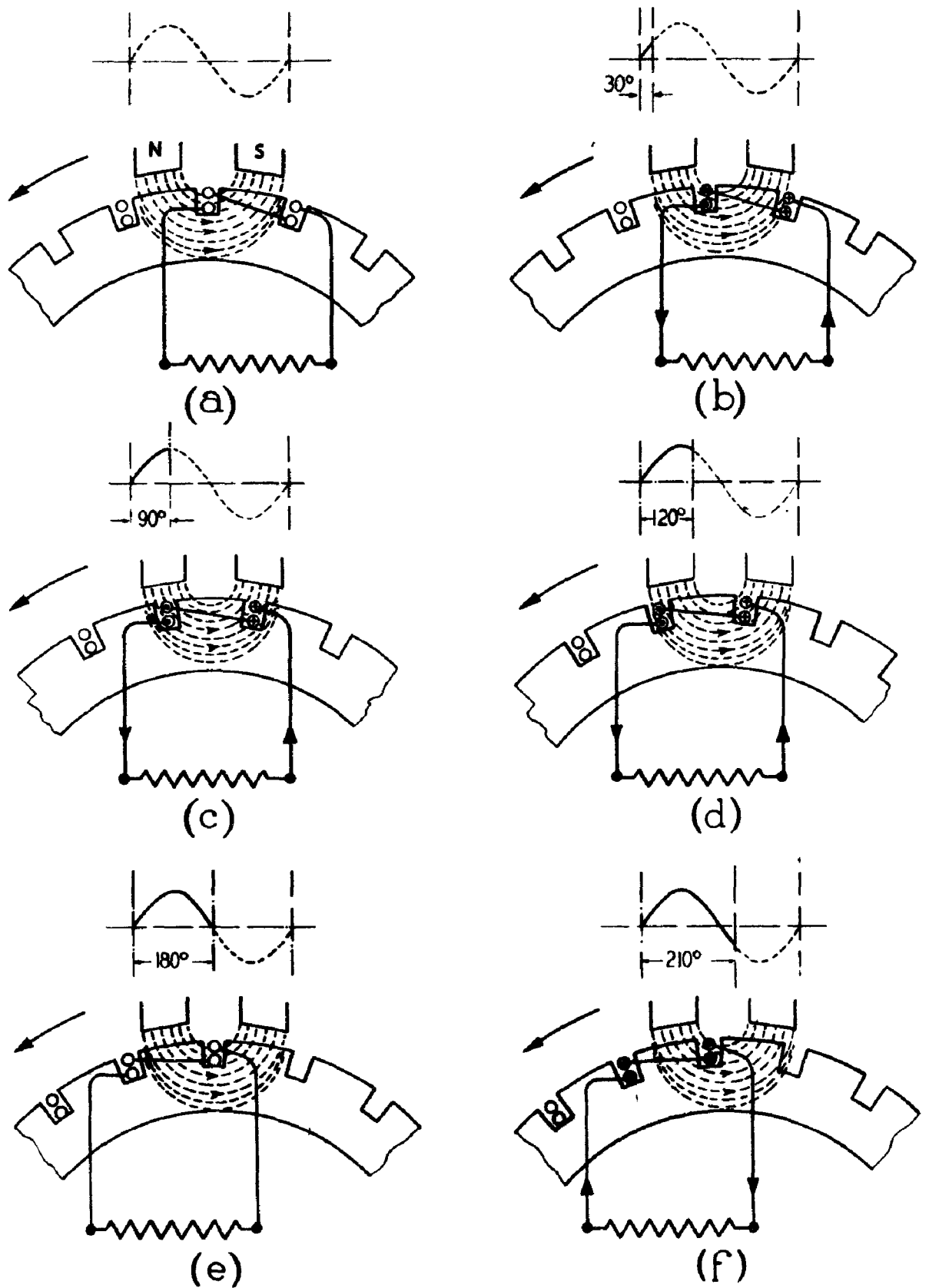

FIG. 10, CHAP. IV.—Slip rings and brushes.

### Rotating field type

14. Instead of employing a wound armature a construction called the salient pole type is sometimes adopted. Fig. 11 shows the field and armature windings of an eight-pole machine of this type in diagrammatic form. If the stationary winding  $W_1, W_2 \dots W_8$  were energized by a direct current an alternating E.M.F. would be induced in the winding carried by the rotating system. If, however, the arrangement is as shown in the diagram, the rotating winding being energized by a direct current, an alternating E.M.F. will be induced in the stationary winding. In order to avoid confusion the term "rotor" is used for the moving member and "stator" for that which is stationary. A salient pole machine may be designed either with a rotor armature and stator field, or with stator armature and rotor field as in the diagram; practically all high voltage alternators of modern design are of the rotor field type, for the mounting, ventilation and insulation of the windings are then much facilitated, and the difficulties of highly insulating the slip rings and brushes are avoided. The constant P.D. between the slip rings rarely exceeds 200 volts, although the alternating P.D. between the ends of the stator winding may be of the order of thousands of volts. In fig. 11 the stator coils are denoted by  $W_1, W_2 \dots W_8$  and the



**E.M.F. IN ARMATURE OF ALTERNATOR**

**FIG. 9  
CHAP. IV**

**This Page Intentionally Blank**

rotor windings and their poles by N, S, N, S. The armature coils are placed end-on to the poles in the diagram so that their inter-connection may be clearly seen, but actually the coils face the pole pieces. Taking any one coil, e.g.  $W_1$ , the inductors are those portions marked k, k. The E.M.F. induced in those inductors which are being transversed by N-poles will be in the reverse direction to that induced in the inductors which are being transversed by S-poles, and the coils must be connected alternately right-handed and left-handed as shown, so that the total effective E.M.F. shall be additive.

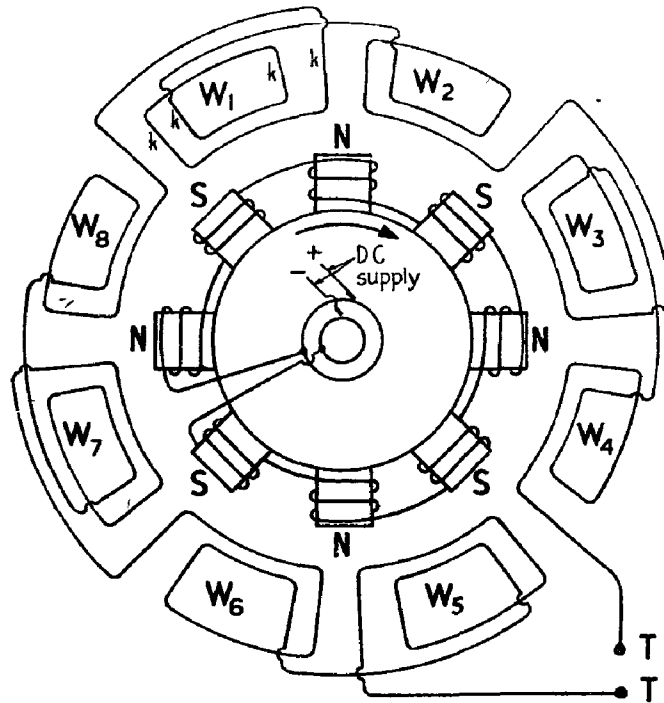

FIG. 11. CHAP. IV.—Alternator windings—stator armature and rotor field.

### Direct current generators

15. The direct current generator makes use of exactly the same principle as the simple alternator described in paragraph 3, the machine being invariably designed with stator field and rotor armature. An alternating E.M.F. is produced in the armature conductors, but the current in the external circuit is uni-directional owing to the action of a device known as a commutator. Let us consider the loop which has already been assumed to rotate in a uniform magnetic field, and in which an alternating E.M.F. is being generated. If instead of being brought to slip rings the two ends of the rotating loop are connected to a single ring which is split longitudinally, i.e. in the direction of the axis of rotation, at two points diametrically opposite, the direction of the current in the external circuit will be reversed when the armature rotates through  $180^\circ$ . Referring to fig. 12a, at the instant depicted, the inductors P and Q are cutting the flux at an angle of  $90^\circ$  and maximum E.M.F. is induced at this instant. By the right-hand rule, the E.M.F. in the inductor P is acting away from and that in the inductor Q towards the reader. Inductor P is connected to the segment (b) of the split ring, while Q is connected to the segment marked (a). As a result, the combined E.M.F. of P and Q causes a current to flow in the external circuit in the direction shown by the arrows. After rotation through  $90^\circ$ , neither P nor Q are cutting the flux and the current falls to zero. During the next  $90^\circ$  of rotation the inductor P is moving toward the position occupied in the diagram by Q, while inductor Q is moving toward that occupied by P, so that the E.M.F. in the inductor P is towards, and that in the inductor Q is away from the reader. The brushes are, however, bearing on the opposite segments and the current in the external circuit is in the same direction as before, thus, although the current in the inductors

**CHAPTER IV.—PARA. 16**

themselves is constantly reversing in direction, the current in the external circuit is uni-directional. In effect the external current consists of half sine waves, flowing always in the same direction but varying in intensity from zero, through a maximum value, and back to zero again, two repetitions of this series of instantaneous values occurring during one rotation of 360 electrical degrees, fig. 12b. The split ring device causing the reversal of current in the external circuit is called a simple or two-part commutator, each of the conducting portions being termed a commutator segment.

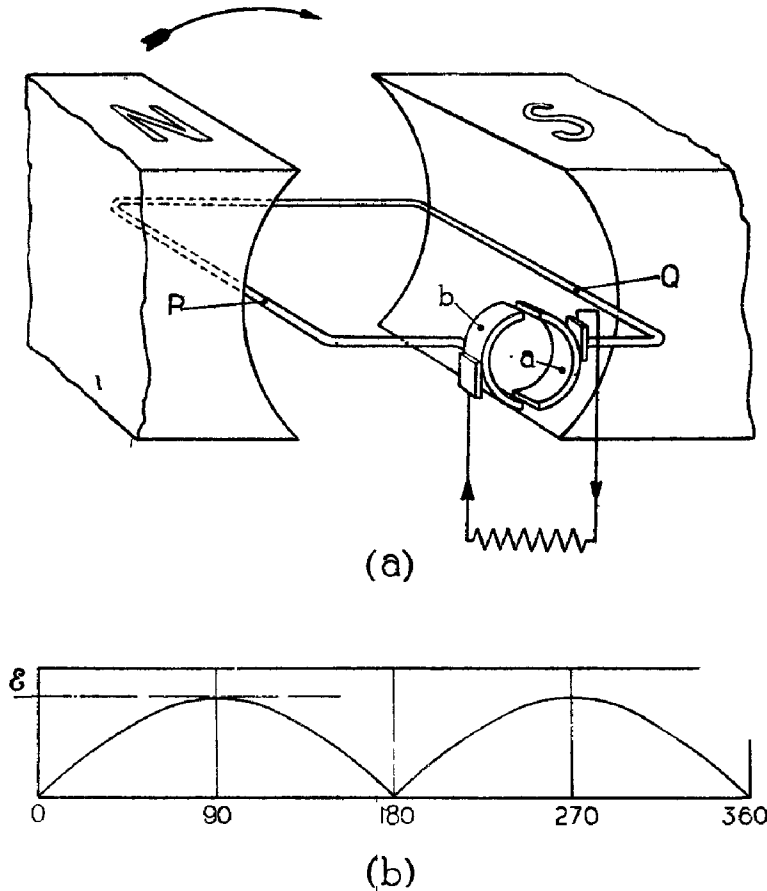

FIG. 12, CHAP. IV.—Principle of commutation.

16. In order to obtain a current which is to all intents and purposes of uniform intensity, it is necessary to use a large number of inductors spaced round the armature core and suitably inter-connected. In fig. 13a two loops are mounted at right angles upon an axis of rotation (not shown) and the ends brought to a commutator having four segments. At the instant depicted the inductors P and Q are cutting the flux at an angle of 90°, and the peak E.M.F.,  $\mathcal{E}$  volts, is induced in each, while the inductors R and S are not cutting the flux and no E.M.F. is induced in them. During the ensuing rotation through an angle of 45°, the E.M.F. in the inductors P, Q, will diminish and that in the inductors R S will increase, and when this amount of rotation has taken place the E.M.F. induced in all four inductors will be the same, viz.  $\mathcal{E} \sin 45^\circ = 0.707 \mathcal{E}$ . At this instant the brushes, which were previously bearing on the commutator segments c and d, momentarily connect segment (d) to segment (b), and segment (c) to segment (a). During the next 90° of rotation they will bear on the segments (b) and (a) only. The E.M.F. during this portion of the rotation will be that induced in the loop R S, which is increasing in value from  $0.707 \mathcal{E}$  to  $\mathcal{E}$ , reaching the latter value after rotation through 90° from its original position.

During one complete revolution, therefore, the E.M.F. applied to the external circuit will vary as shown by the heavy line in fig. 13b, and never rises above the value  $\mathcal{E}$  volts nor falls below the value  $0.707 \mathcal{E}$  volts.

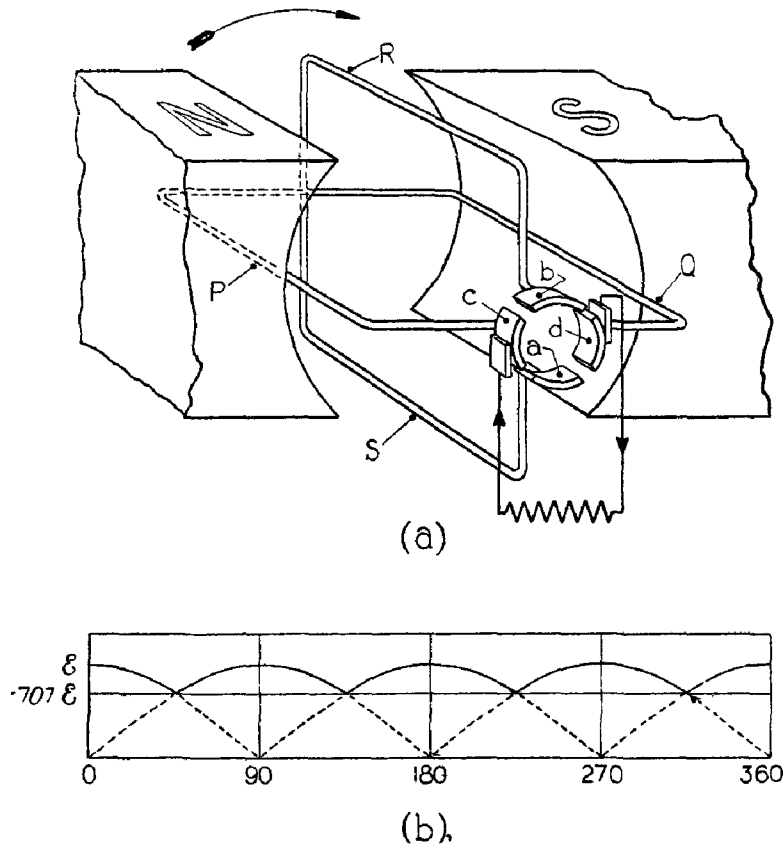

FIG. 13, CHAP. IV.—Approach to uniform E.M.F.

17. It will be observed that with this arrangement the effective E.M.F. is only that of the loop to which the external circuit is connected by the commutator and brushes, the E.M.F. in the other loop being applied to no useful purpose. By suitably interconnecting the loops the E.M.F. in both loops may be utilized. The principle of the closed winding, as it is called, may be explained with reference to fig. 14, in which the armature has two coils each having two complete turns, and the winding is closed upon itself. That this is so is easily traced out, starting say, from segment (a) via inductors P Q to segment (c), then via inductors R S to segment (b). From this point the winding continues via the inductors Q' P', to segment (d) and inductors S' R', terminating upon segment (a) and thus closing the winding. Assuming that the brushes are so thin that they just bridge over two adjacent segments at the instant of commutation, it will be seen that the E.M.F. applied to the external circuit varies from  $\mathcal{E}$  to  $1.414 \mathcal{E}$  during the rotation of the armature. Let the brushes—which have been omitted from the diagram for clearness—be on the neutral axis, i.e. midway between the poles, so that at the instant depicted in the diagram they are bearing on segments (a) and (b). From the segment (a) we may now trace two paths through the armature

(1) (a) P Q (c) R S (b)

In this path the indicators R and S are cutting the flux at maximum velocity, while P and Q are not cutting flux hence the general E.M.F. in this path is  $\mathcal{E}$  volts.

(2) (a) R' S' (d) P' Q' (b)

## CHAPTER IV.—PARA. 18

This path is in parallel with path (1) and also has a generated E.M.F. of  $\mathcal{E}$  volts. When the armature has rotated through very nearly  $45^\circ$ , the upper and lower brushes are just about to leave the segments (a) and (b) respectively. All inductors are now cutting flux at approximately  $45^\circ$ , and the E.M.F. induced in each pair of inductors is  $0.707 \mathcal{E}$  volts. Tracing out the paths as above, then, it is seen that in each path the generated E.M.F. is  $2 \times 0.707 \mathcal{E} = 1.414 \mathcal{E}$ . Thus, during rotation, the generated E.M.F. varies as shown in fig. 14b. The dash line shows the E.M.F. of one loop and the chain line that of the other, while the solid line is the sum of the two. The fact that there are two paths in parallel through the armature implies that the internal resistance of the winding is reduced. The above arrangement is however hardly a practicable arrangement because commutation troubles would arise.

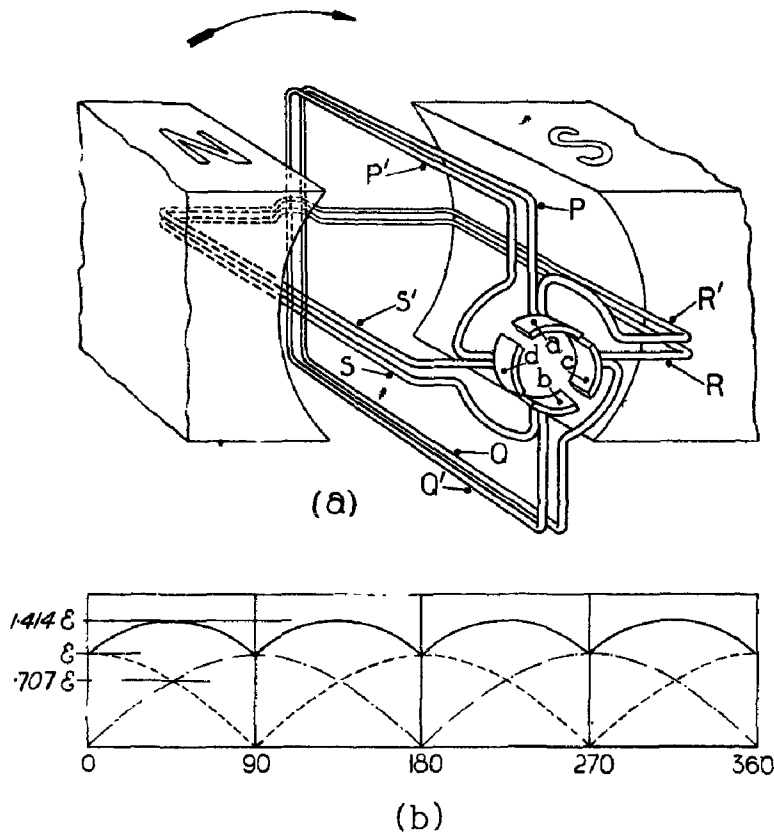

FIG. 14, CHAP. IV.—Principle of closed winding.

18. The practical form of D.C. generator consists of the following essentials:—

- (i) The field magnets, which provide the magnetic field in which the conductors rotate.
- (ii) The field magnet windings, which are conductors carrying the magnetizing current for the field magnets. These windings are of course absent in machines fitted with permanent field magnets.
- (iii) The armature core and spider. The core is of soft iron and is laminated as in the alternator, for the same purpose. The spider is an arrangement by which the armature core is mounted on its shaft.
- (iv) The armature winding, which is the system of conductors in which the E.M.F. is induced. Various forms of winding are described below.
- (v) The commutator.

(vi) The brushes, which are metal or carbon current collectors. These rest upon the commutator and convey the current to the external circuit. The brushes are supported by the brush gear, which allows the position of the brushes to be shifted round the periphery of the commutator for reasons which will be apparent later.

19. Except in small low power machines, an electro-magnetic field system is generally adopted, the disadvantage of permanent magnets being as already stated when dealing with the alternator. In spite of this disadvantage, certain low power generators for W/T purposes in aircraft utilize a permanent magnet field in order to remove the necessity for providing a heavy magnetizing current. Small D.C. generators are usually bi-polar, having one N-pole and one S-pole, but for outputs greater than about five kilowatts, multi-polar construction is practically universal, either a four-pole or six-pole design being adopted; turbo-generators running at very high speed generally utilize the bi-polar construction even for outputs of 1,000 kilowatts or more. The field magnet windings are generally supplied with current by the machine itself, and the latter is then said to be self-excited, differing in this respect from the alternator, which is usually provided with field magnet excitation from a separate source. It must be observed that if the field magnet is absolutely without magnetic properties when the armature is initially set in rotation, no E.M.F. can be developed in the latter and consequently it can supply no excitation to the field. Usually, however, the field magnets possess some slight residual magnetism, and on rotation the armature generates a small E.M.F., consequently a small current is established in the field windings. This current is normally in such a direction as to strengthen the residual magnetism of the field magnet so that the generated E.M.F. is progressively increased, and is commonly said to "build up" to the final value. If the residual magnetism is destroyed, e.g. if the pole pieces are removed from the carcass during the course of repairs, the machine may fail to excite on first running after re-assembly. An initial field current must then be provided by means of an accumulator battery. The commutator consists of a number of segments of hard copper, usually manufactured by drop-forging. These are insulated from each other by sheet mica, and from the frame with which they are secured to the shaft by micanite rings. The stationary brushes rest on the segments and carry the current to and from the armature winding.

20. The armature coils or bars are connected to each other and to the commutator in one of two methods known as wave winding and lap winding respectively. In both forms, two separate inductors are placed in each slot in the armature. A single winding unit may be defined as a portion of the winding which is connected between two commutator segments, and the pitch of the winding as the distance between two inductors which are in direct connection. Instead of actually stating the pitch in terms of length it is more convenient to express it as the number of inductors passed over in so inter-connecting any two. The inductors forming the active portions of a winding unit must be situated in fields of opposite polarity in order that the E.M.F.'s induced in each shall be additive. The width of a winding unit will therefore be, as nearly as possible, equal to the pole pitch, i.e. the circumference of the armature divided by the number of poles. The inter-connection at the commutator end is referred to as the front pitch,  $y_f$ , and that at the opposite end as the rear pitch,  $y_r$ . For example, in fig. 15, the inductors are numbered consecutively, and the inductor (1) is connected at the rear end to the inductor (6); the rear pitch is therefore 5. At the front end the inductor (6) is joined to the inductor (11), and the front pitch is also 5. If the front and rear pitches differ, the difference is always an even number and the mean pitch,  $y$ , is equal to  $\frac{y_f + y_r}{2}$ . The front and rear pitches are so adjusted that the

winding shall be closed upon itself. Starting from any inductor, and tracing through the whole system of winding, each inductor must be traversed once and once only, before returning to the original inductor. The winding is then said to be re-entrant.

**CHAPTER IV.—PARAS. 21-22**

**Wave winding**

21. In this type of winding both front and rear pitches are invariably odd numbers. If there are  $N$  inductors, the mean pitch is  $(N + 2)$ , or  $(N - 2)$ , divided by the number of field poles. If the mean pitch is odd, the front and rear pitches are equal, i.e.  $y_f = y_r = y$ . If the mean pitch is even, the front pitch may be greater than the mean pitch by unity, and the rear pitch less than the mean pitch by unity, or

$$y_f = y + 1$$

$$y_r = y - 1.$$

Alternatively, it is permissible to arrange that  $y_r = y + 1$  and  $y_f = y - 1$ . Fig. 15 is what is called an expanded winding diagram and illustrates the method of wave winding in a four-pole machine. The armature and pole pieces are imagined to be laid out on a plane, the inductors being numbered (1) to (22) and the commutator segments (a) to (k). As  $N = 22$ , the mean pitch may be either  $\frac{22 + 2}{4} = 6$  or  $\frac{22 - 2}{4} = 5$ . If the value 6 were taken, the front and rear pitches would be 7 and 5 respectively. In the diagram, however, the mean pitch has been taken as 5, and the front and rear pitches are both equal to the mean pitch. Commencing from the commutator segment (a) two complete winding units are shown in heavy line to assist in tracing the circuit. The position of the poles is also indicated, but it must be remembered that they are really situated above or below the paper. Assuming they are above, the direction of the induced E.M.F. is found by the right-hand rule, and is marked on the inductors by arrows. As the inductors shown by dotted lines lie underneath those immediately adjacent (solid lines), certain inductors must be given an E.M.F. although, as drawn, they appear to lie outside the influence of the field. For example, inductor (5) lies beneath inductor (4), and equal E.M.F.'s are induced in each.

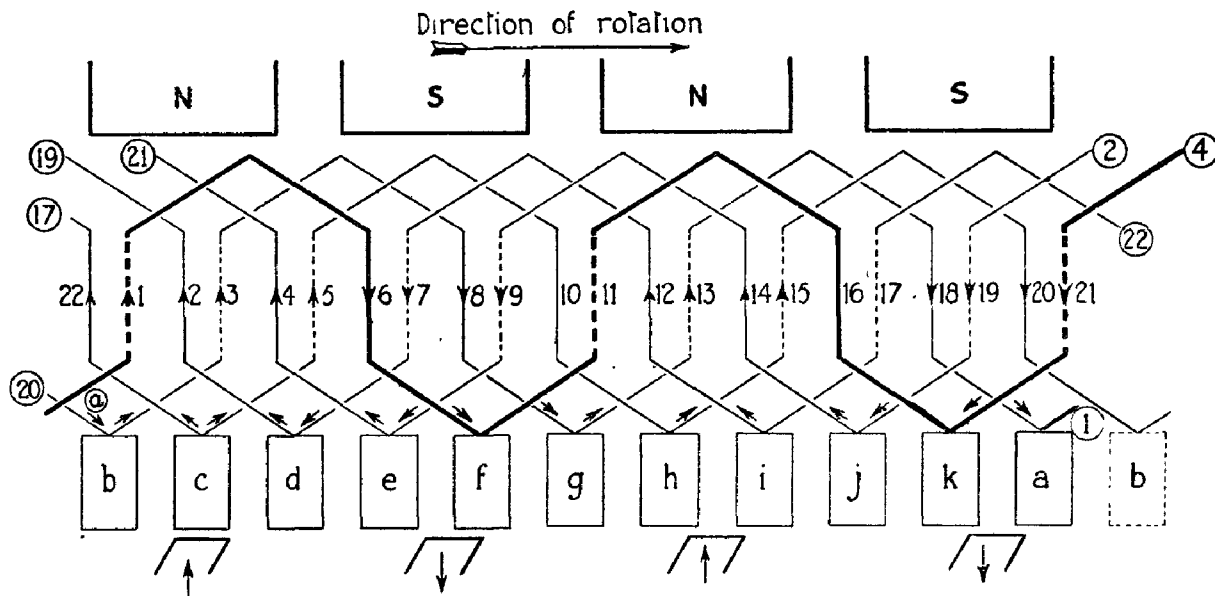

FIG. 15, CHAP. IV.—Principle of wave winding.

22. The positions on the commutator at which the brushes should be placed are found as follows. Assuming that in the front connectors current will only flow as a result of the E.M.F. in the inductors connected thereto, place arrows beside the connectors to indicate the direction of current. It will then be seen that current flows both toward and away from certain segments, while at others current flows only in a single direction, and these are the positions at which brushes should be placed. At segment (c) current flows away from the commutator to inductors (22) and (5); current may therefore enter the winding by a brush placed on this segment. At

segments (k) and (a) current flows only from inductor (21), inductor (16) having no induced E.M.F. and a second brush placed between these segments will convey current away from the commutator. These brushes are 90° apart and are sufficient for the correct performance of the machine. Alternatively, the brushes could be located on segments (f) and between segments (h) and (i). In practice, therefore, two pairs of brushes are often fitted and connected in parallel, in order to reduce the current density in the commutator segments.

**Lap winding**

23. In a lap winding the front and rear pitches are both odd, and differ by 2, making the mean pitch an even number. Fig. 16 shows the developed diagram of a four-pole machine having 24 inductors and 12 commutator segments. The mean pitch in this form of winding is given by

$$y = \frac{\text{number of inductors}}{\text{number of poles}}$$

and in the given example is 6. The front pitch is  $y - 1 = 5$ , and is contrary to the direction of rotation, hence it is given a negative sign and becomes  $-5$ . The rear pitch is in the direction of rotation and is equal to  $y + 1$ , or 7. One complete winding unit, shown in heavy line, starts from segment (a), thence to inductor (1), via the rear connector to inductor (8) and by the front connector to segment (b). The winding then continues in an overlapping manner from which the term lap winding is derived. Arrows are placed upon the inductors to indicate the direction

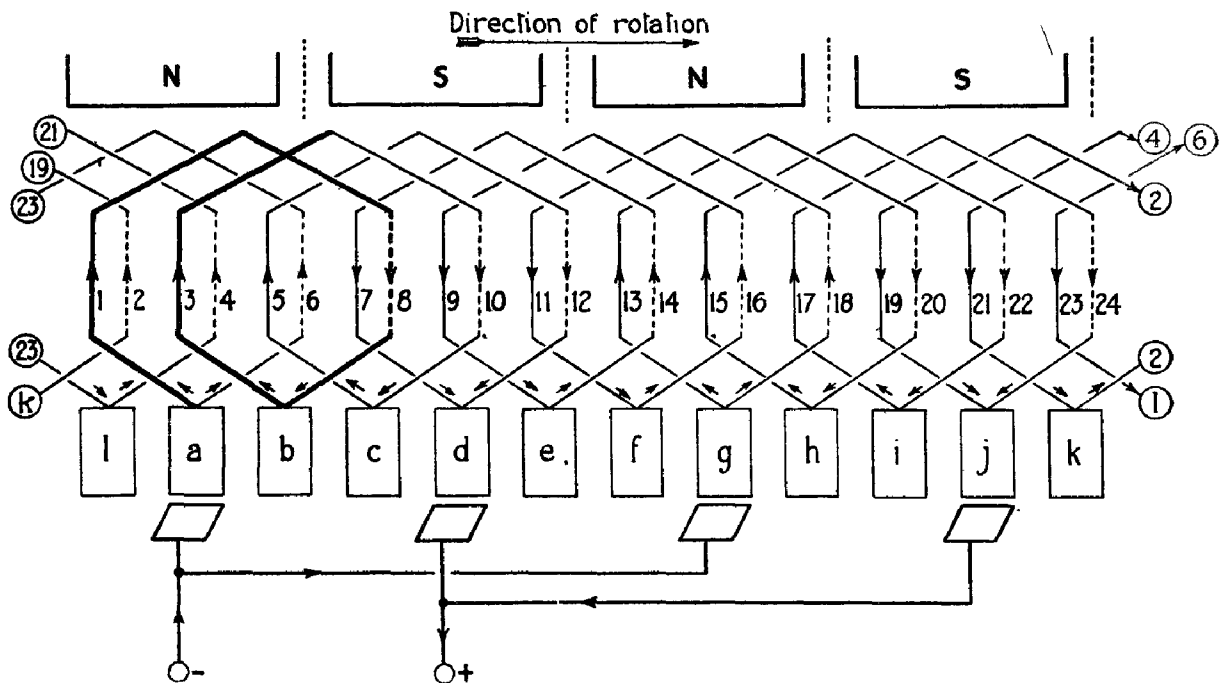

FIG. 16, CHAP. IV.—Principle of lap winding.

of the induced E.M.F., and beside the front connectors to denote the direction of current. It will be seen that current reaches the commutator from inductors (7) and (12) at segment (d), and from inductors (19) and (24) at segment (j), while current leaves the commutator at segments (a) and (g). It is possible to trace four separate paths through the armature, viz:—

- (i) from segment (a) through inductors (1, 8, 3, 10, 5, 12) to segment (d);
- (ii) from segment (a) through inductors (6, 23, 4, 21, 2, 19) to segment (j);
- (iii) from segment (g) through inductors (13, 20, 15, 22, 17, 24) to segment (j);
- (iv) from segment (g) through inductors (18, 11, 16, 9, 14, 7) to segment (d).

## CHAPTER IV.—PARAS. 24-25

Thus there are as many paths through the armature as there are poles. Current is taken from the armature by brushes placed on the commutator at segments (d) and (j), and returns to it by brushes placed at segments (a) and (g). In a lap wound machine, therefore, one pair of brushes must be provided for each pair of poles.

24. In the foregoing explanation, the armature is assumed to consist of a series of single inductors suitably connected to each other and to the commutator, but in practice each winding unit may consist of a coil of several turns, particularly in machines designed to give a high voltage. Thus in fig. 16, taking the winding unit shown in heavy line and starting from segment (a), the conductor would follow the path through the slot occupied by inductor (1), via the back connection occupied by inductor (8), and then, instead of terminating upon the segment (b), would be carried on via a front connection to the slot occupied by inductor (1) thence to that occupied by inductor (8) and so on, forming a coil of several complete turns which is finally terminated on the commutator at segment (b). This is termed an armature coil, and is generally made by winding double cotton-covered wire on a suitably shaped wooden former, the turns being bound together with cotton tape and varnished.

### Magnitude of E.M.F.

25. The total E.M.F. developed in the armature is easily found by the following method.

Let

- $n$  = r.p.m.
- $\Phi$  = total flux of per pole.
- $p$  = number of pairs of poles.
- $a$  = number of pairs of paths through armature.
- $N$  = number of armature conductors.

When an armature loop, i.e. a pair of conductors, moves from a position in which it embraces the whole of the flux from a N-pole, to a similar position with reference to a S-pole, the total flux change is  $2\Phi$ , because each tube of flux is cut twice during the movement, which takes place in  $\frac{1}{p}$  of a revolution. The time of one revolution is  $\frac{1}{n}$  of a minute or  $\frac{60}{n}$  of a second; the time taken by the above change of flux is therefore  $\frac{1}{2p} \times \frac{60}{n}$  second. The average E.M.F.  $E_1$  induced in one loop is equal to the total change of flux divided by the time occupied by the change and therefore

$$E_1 = \frac{2\Phi}{\frac{1}{2p} \times \frac{60}{n} \times 10^8} \text{ volts.}$$

The number of armature loops in series is  $\frac{N}{4a}$  and the total average E.M.F. is

$$\begin{aligned} E &= \frac{4n p \Phi}{60 \times 10^8} \times \frac{N}{4a} \text{ volts} \\ &= \frac{n N \Phi}{60 \times 10^8} \times \frac{p}{a} \text{ volts.} \end{aligned}$$

For a wave wound armature,  $a = 1$ , and

$$E = \frac{n N \Phi}{60 \times 10^8} \times p \text{ volts.}$$

For a lap wound armature,  $a = p$ , and

$$E = \frac{n N \Phi}{60 \times 10^8} \text{ volts.}$$

*Example*

The flux in an eight-pole dynamo is 2,400,000 lines per pole. The armature has 740 conductors and is lap-wound. Find the induced E.M.F. at a speed of 800 r.p.m.

$$\Phi = 2.4 \times 10^6$$

$$n = 800$$

$$N = 740$$

$$E = \frac{800 \times 740 \times 2.4 \times 10^6}{60 \times 10^3}$$

$$= 236.8 \text{ volts.}$$

**Power output of D.C. generator**

26. Up to the present, reference has been made to E.M.F. generated by the rotation of conductors in the magnetic field and to current flowing in various portions of the circuit, without any reference to energy converted from mechanical into electrical form. When the external circuit is incomplete, no electrical energy is supplied to the external circuit, and the energy supplied by the steam engine, petrol motor, or other means of rotation, has only to turn the armature against the various forms of friction which are present. When the external circuit is completed, and a current is established, electrical energy is supplied to the external circuit, the rate at which this energy is supplied being called the power output of the generator. This power must be supplied by the mechanical source, and the load on the latter increases with the power output. The current flowing through the external circuit must also flow through the armature, and the latter then constitutes a system of current carrying conductors situated in a magnetic field. Now in the preceding chapters it has been shown that such a conductor experiences a force, which tends to cause it to move in a direction which may be found in the left-hand rule. Applying this to the simplest instance, i.e. a single rotating loop carrying current in a bi-polar field, it is found that the force tends to turn the loop in the opposite direction to that in which it is actually rotating, and must be overcome by the supply of additional power by the mechanical source.

**Torque**

27. The turning moment just referred to is called the electro-dynamic torque of the armature and is measured in pounds-feet, because it is the product of the force applied (in pounds) and the radius (in feet) of the path in which each conductor tends to turn. If a torque of  $T$  pounds-feet is allowed to act through one complete revolution, the work done is  $2\pi T$  foot-pounds. Alternatively, if the radius of a certain path is  $r$  feet, and a force of  $P$  pounds is acting in this path, the work done in one rotation is  $2\pi rP$  foot-pounds, the product  $rP = T$  being the torque exerted. If rotation takes place at a speed of  $n$  r.p.m., work is performed at a rate of  $2\pi nT$  foot-pounds per minute or  $\frac{2\pi nT}{60}$  foot-pounds per second, and this is the power required to cause the rotation. It is convenient to convert this into horse-power (H.P.) since this unit of power is generally used for mechanical power. As one H.P. = 33,000 foot-pounds per minute or 550 foot-pounds per second, the power which the mechanical source must supply, in order to overcome the electrodynamic torque, is  $\frac{2\pi nT}{33,000}$  H.P. This mechanical power is completely converted into electrical power, the latter being  $E I_A$  watts, where  $E$  is the E.M.F. generated and  $I_A$  the armature current. As  $E I_A$  watts are equal to  $\frac{E I_A}{746}$  H.P.,

$$\frac{2\pi nT}{33,000} = \frac{E I_A}{746}$$

$$T = \frac{E I_A \times 33,000}{746 \times 2\pi n}$$

**CHAPTER IV.—PARAS. 28-29**

In a previous paragraph it was shown that for either lap or wave wound armatures, the E.M.F. generated is directly proportional to the magnetic flux per pole,  $\phi$ , and directly proportional to the speed  $n$ . As a result the torque becomes independent of the speed and dependent only upon the amount of flux per pole and the armature current, or

$$T \propto \phi I_a.$$

**Armature reaction**

28. Hitherto, the magnetic field in which the armature is rotated has been considered to be of uniform density, and established entirely by the field magnets. As we have seen, the armature itself is a system of current-carrying conductors, and must also set up a magnetic field in the space between the field poles. The total flux in this space is therefore made up by the superposition of the armature field upon the field due to the stator winding. Before proceeding further, it is pointed out that in diagrams illustrating the results of this super-position, it is customary to omit the commutator, and to show the brushes as bearing directly upon the armature conductors. This is not unreasonable, for the commutator may be regarded merely as a portion of the armature winding which has been bared of insulation in order to make contact with the external circuit by means of the brushes. Fig. 17a shows the field magnets and armature in section, the direction of current in the armature conductors being indicated conventionally. The armature current is here supposed to set up no magnetic flux, and in these circumstances the proper position of the brushes would be as shown, i.e. making contact with the conductor in which no E.M.F. is being generated at the moment.

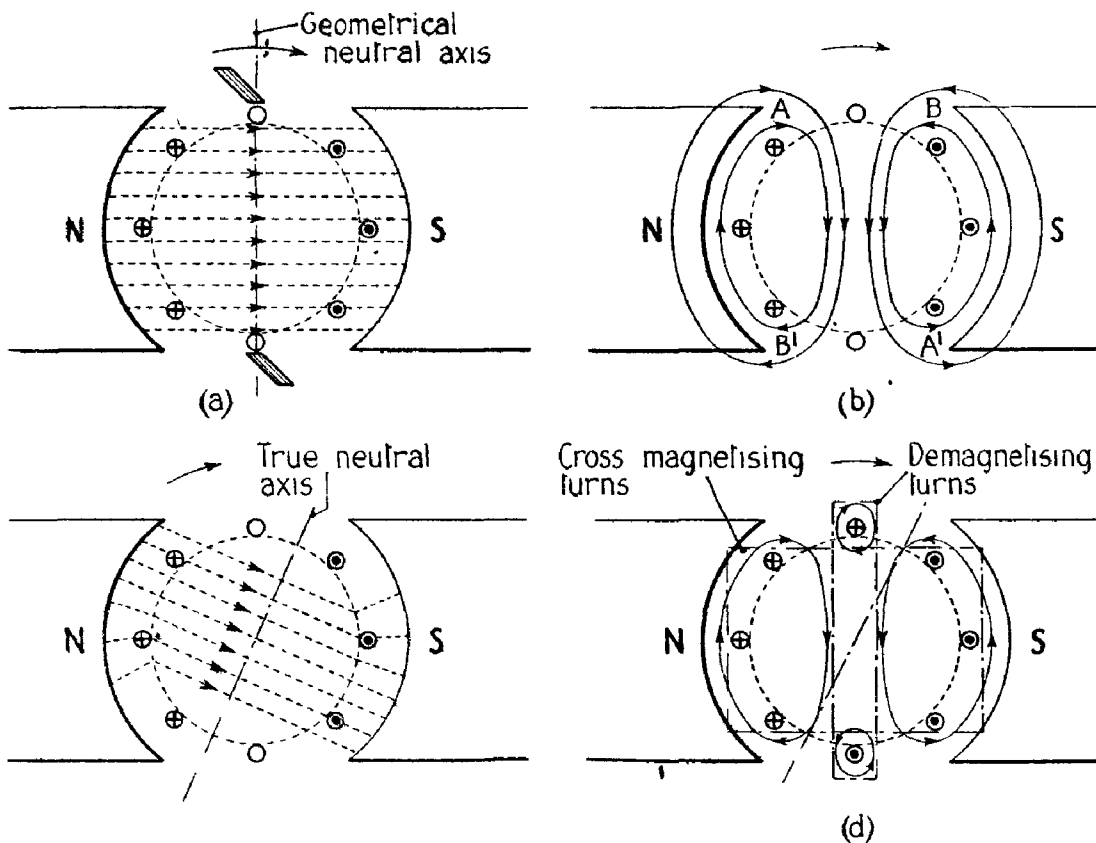

FIG. 17, CHAP. IV.—Armature reaction in D.C. generator.

29. The field due to the current in the armature is shown in fig. 17b. It is seen to be in the same direction as the stator field at the points A A', and in the opposite direction to the stator field at the points B B'. With reference to the direction of rotation, the points A A' are referred

to as the trailing pole tips, and the points B B' as the "leading pole tips". The direction of the armature field being at right angles to the stator field, this effect is referred to as cross-magnetization, and its result is to distort the total effective flux in the direction of rotation as shown in fig. 17c. If the brushes are to be placed upon the conductors in which no E.M.F. is being induced, they must be shifted round in the direction of rotation, so that their position is upon the electrical neutral axis as indicated in this diagram. The current distribution in the armature conductors now differs from that shown in fig. 17a, becoming as illustrated in fig. 17d. The conductors on the armature may now be divided into two groups at right angles to each other, one group causing cross-magnetization as before, and the other causing a magnetic field which is parallel to the stator field but of opposite polarity, and therefore this component tends to weaken the flux. This weakening is referred to as the demagnetizing effect. The principal results of this factor in armature design are (i) to cause a reduction in E.M.F. for a given field current, and (ii) to cause an uneven distribution of the voltage between the various armature coils, and consequently a greater strain on the insulation between some commutator segments than between others. The commutator must therefore be designed with a larger margin of safety than would otherwise be necessary.

**Sparking**

30. Sparking at the brushes is caused by the inductance of the armature windings, which gives rise to what is called the reactance voltage of the coil. This is a true E.M.F. of self-induction due to the change of current in the coil, and must not be confused with the E.M.F. induced in it owing to its rotation. Fig. 18a shows a portion of an armature winding and its connection to the commutator, in the vicinity of the positive brush. The coil B' is short-circuited by the brush; current is flowing towards the brush from c' to c, i.e. downward, in the coil C', and from a' to b, i.e. downward, in the coil A'. In fig. 18b the coil B is about to undergo commutation. The

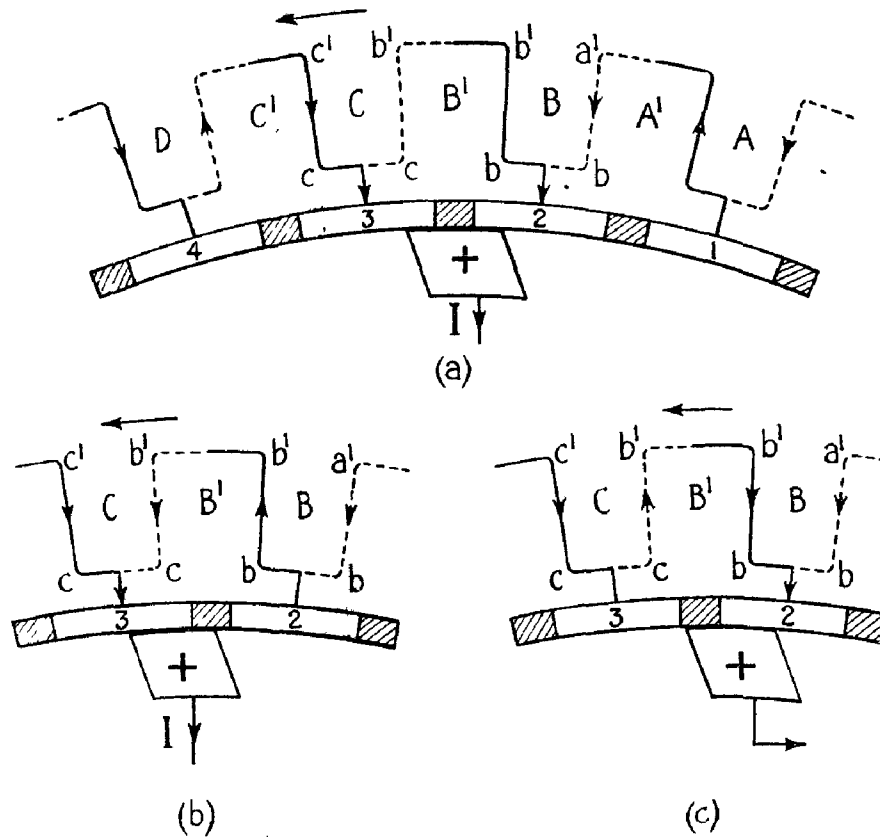

FIG. 18, CHAP. IV.—Commutation.

## CHAPTER IV.—PARAS. 31-32

current in the conductor  $b b'$  is in the upward direction, while in fig. 18c, the commutation has been performed and the current in  $b b'$  is in the downward direction. The total armature current is  $I$ , and in the armature itself there are two paths in parallel, so that commutation implies a change of current from  $+\frac{1}{2}I$  to  $-\frac{1}{2}I$ , or a change of  $I$  amperes during the time of commutation, i.e. while the brush is short-circuiting segments (2) and (3), as in fig. 18a. Under ideal conditions, the change of current would take place uniformly, as shown by the dotted line BC in fig. 19a. Here OA is the current  $+\frac{1}{2}I$  before commutation, and NC the current  $-\frac{1}{2}I$  afterwards. In practice, however, the reversal is delayed owing to the counter-E.M.F. of self-induction due to the change of current in the coil, and the actual change of current may be as shown by the curved line BE. At the end of the short-circuit time, the current has assumed the value NE instead of NC and must change from NE to NC very suddenly. It is this sudden change of current which causes a large induced E.M.F. and a corresponding spark to pass from the segment (3) to the brush.

### Methods of reducing sparking

31. One method of reducing sparking is by giving the brushes a forward lead in order to bring the short-circuited coil into a reversing field. It has already been stated that one effect of armature reaction is to necessitate a forward lead of the brushes so that commutation may take place in zero field. By moving the brushes still further in the same direction the coil is commutated in a reversing field and remains short-circuited after it has commenced to cut the flux in the new direction. The induced E.M.F. due to this cutting of flux opposes the original current in the coil. If an excessive lead is given, the induced E.M.F. will more than balance the reactance E.M.F. and the current in the coil will be greater than  $\frac{1}{2}I$  in magnitude so that at the end of the short-circuit time it will have to change abruptly and sparking will again occur (fig. 19b). When the induced and reactance voltages are exactly balanced, at the end of the commutation period, the change of current is somewhat as shown in fig. 19c and no sparking takes place. The use of carbon brushes is of great assistance in the attainment of sparkless commutation. The resistance of the carbon-copper contact is comparatively high, and this tends to cause the current change during commutation to follow the straight line BC of fig. 19a.

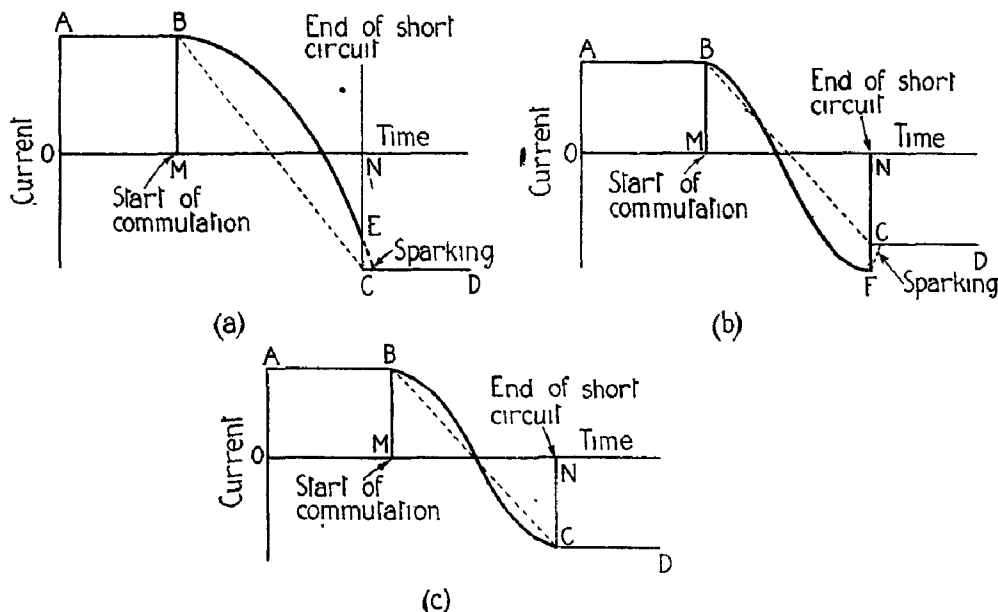

FIG. 19, CHAP. IV.—Current variation during commutation.

32. Minor advantages of carbon brushes are:—

- (i) If properly "bedded" in the first place, carbon brushes lubricate and polish the commutator.

(ii) If sparking does occur, less damage to the commutator ensues than with copper brushes.

Their chief disadvantages are :—

(iii) Owing to their high resistance (which is essential to obtain the benefit of improved commutation) an  $I R$  drop of about 2 volts takes place at each brush. This effect is only serious on low voltage machines.

(iv) The heat generated in the brush to this high resistance raises the temperature of the commutator, and the latter must be made larger than if copper brushes were used, in order to radiate the heat.

In modern machines, inter-poles are often fitted to assist commutation. In such circumstances the brushes are placed upon the electrical neutral axis, and a reversing field is provided by means of a field winding upon special poles placed midway between the main poles. This winding generally carries the full armature current and is therefore a series winding. The polarity must be that of the next main pole in the direction of rotation.

**Methods of connecting the field windings**

33. Self-excited generators may be classed as series, shunt, or compound wound, the distinction being in the manner in which the field circuit is connected with reference to the armature. The series wound machine is shown diagrammatically in fig. 20a. The field winding

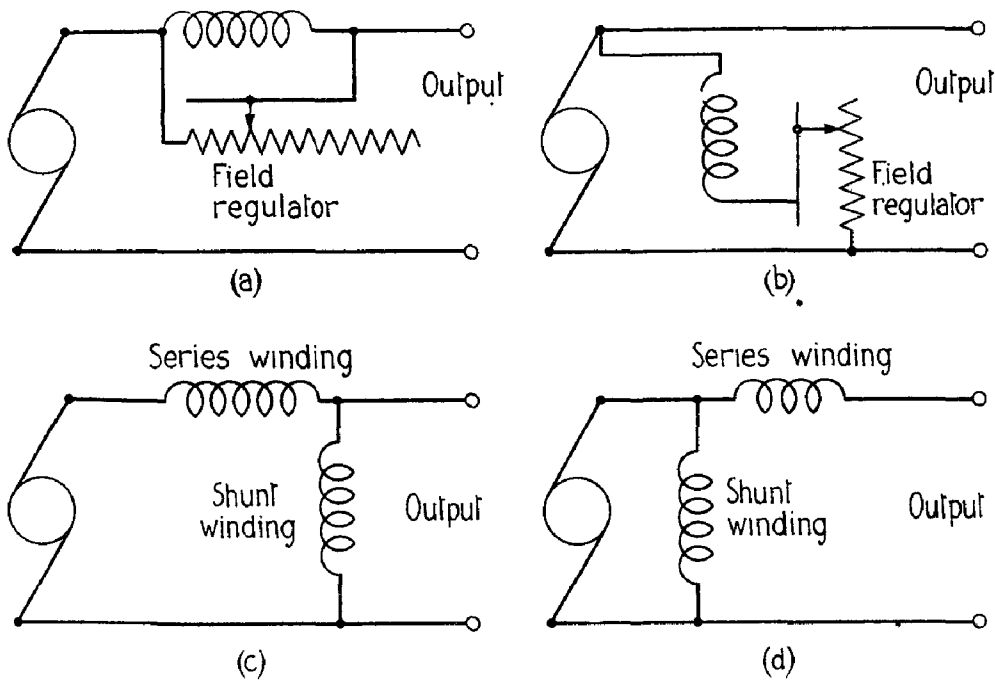

FIG. 20, CHAP. IV.—Methods of connecting field windings.

carries the full armature current or a large fraction thereof, hence to provide the required ampere-turns only a few turns of wire of large cross-section are required. Fig. 20b shows the shunt-wound machine, in which a small portion of the armature current is diverted from the external circuit for the purpose of providing the field ampere-turns, and the number of turns must be large, although the cross-section of the wire is small. The excitation is adjusted by means of a field regulator, which is a rheostat of suitable current-carrying capacity. In the series-wound machines the field regulator is in parallel with the field magnet winding and so diverts a portion of the load current from that path, while in the shunt-wound machine the field regulator is placed in series with the field magnet windings. The compound winding is a combination of the two and may be either "long shunt" or "short shunt" as shown in fig. 20c and fig. 20d respectively. The behaviour of generators with different types of field excitation can be shown

## CHAPTER IV.—PARAS. 34-35

by means of the characteristic curves of the generator. These are graphs of the relation between current and voltage when the generator is run at constant speed. The most important of these curves is the "external characteristic" which shows relation between the terminal P.D. and the current flowing in the external circuit.

### Separately excited or permanent-magnet field generator

34. As a basis of comparison, it is convenient to use the external characteristic of a separately excited machine, which is identical with that of a machine having a permanent-magnet field, because the stator flux is quite independent of the armature current, although of course the total field is influenced by the effects of armature reaction. In fig. 21 the E.M.F. generated at constant speed is shown by the line AB and is nearly constant for all values of output current. The dotted horizontal line is inserted in order to show the extent of the deviation. The terminal P.D. is shown by the line AC; it falls off gradually as the current output is increased, that is, as the resistance of the external circuit is decreased. The difference between the E.M.F. on no load and the terminal P.D. at full load is called the regulation of the machine, and if the fall in terminal voltage at full load is only slight, the machine is said to have good regulation. The difference between the E.M.F. and the terminal P.D. is chiefly caused by the increase in the potential drop in the armature itself. This is equal to the product of the armature current and the armature resistance. The lower the resistance of the armature, therefore, the better will be the regulation of the generator. The small potential drop at the brushes must also be taken into account.

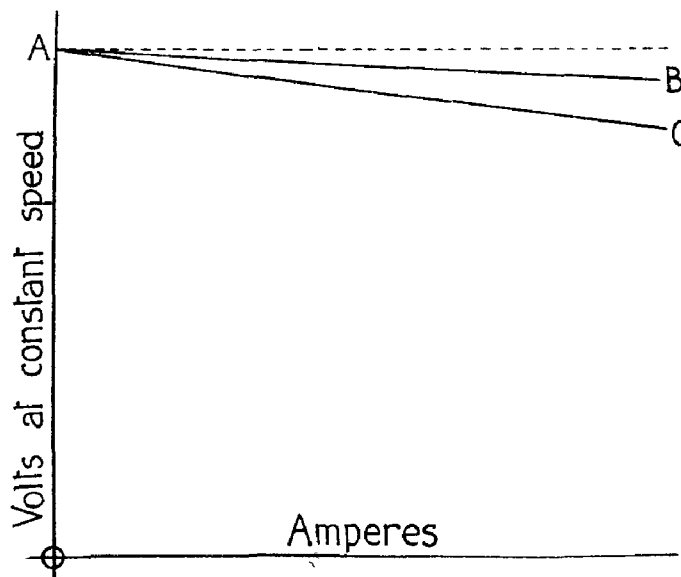

FIG. 21, CHAP. IV.—External characteristic of separately excited generator.

### The shunt-wound generator

35. The external characteristic of this type of generator is given in fig. 22. In the first place, consider the E.M.F. generated. If no current is taken by the external circuit, the E.M.F. builds up to some steady value, and as the machine has only to supply the small field magnetizing current, the terminal P.D. is practically equal to the E.M.F. OA. If an external circuit of variable resistance is connected to the generator terminals, the variation of terminal P.D., within certain limits, is similar to that of a separately excited machine, as shown by the portion AB of the characteristic. For a given load current, the fall of P.D. is somewhat greater because as the terminal P.D. falls, the field current diminishes and the excitation is correspondingly reduced. If the external resistance is reduced below the value corresponding to the point B, however, the terminal P.D. falls to some very small value such as OC, which is maintained almost entirely

by the residual magnetism. For any given machine, then, there is some maximum current output which cannot be exceeded. The corresponding value of external resistance is found by drawing a tangent OTP to the curve from the origin O. This tangent should just touch the characteristic curve at the point T. (In the diagram a slight clearance has been left for distinctness.)

The slope  $\frac{PN}{ON}$  has the dimensions  $\frac{\text{volts}}{\text{amperes}}$  and is therefore a resistance. If the resistance of the external circuit falls below this value, the machine fails to excite. It is obviously desirable to start up a shunt-wound generator on open circuit, and allow the E.M.F. to build up to its normal value OA, before connecting the external circuit.

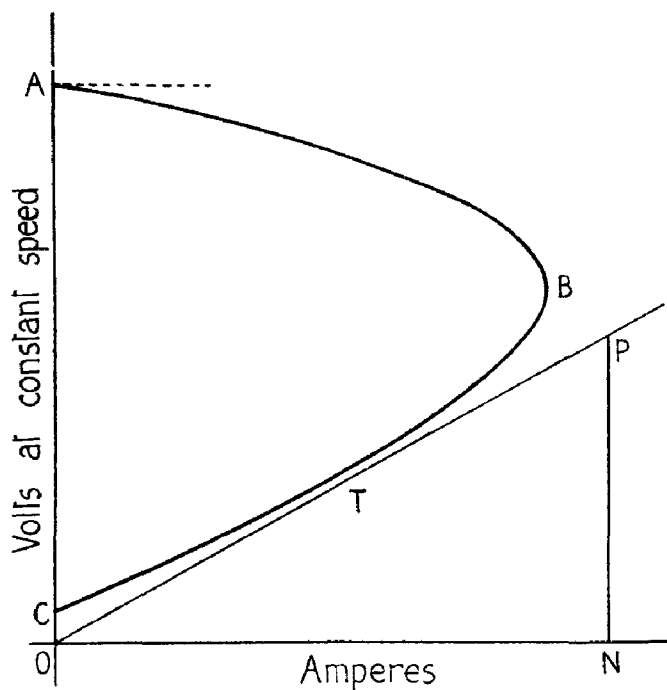

FIG. 22, CHAP. IV.—External characteristic, shunt-wound generator.

### Series-wound generator

36. In this machine the field current (neglecting the small fraction taken by the field regulator if fitted) is the same as the armature current, and the E.M.F. increases as the field current increases, i.e. as the external resistance is reduced. For low output currents, the increase in terminal P.D. is proportional to the increase in armature current, but near full load this proportionality fails owing to the increasing reluctance of the magnetic circuit at high flux density. As shown by the dotted line in fig. 23, the E.M.F. tends to become constant, but the terminal P.D. reaches a maximum value and then falls, because the increase of E.M.F. due to the stronger field is less than the increased fall of P.D. in the field magnet and armature windings. The terminal P.D. therefore varies with the load current in the manner shown by the curve OBC. The corresponding values of load current and terminal P.D. for any given external resistance may be found by drawing a line such as OR, having a slope equal to the stipulated external resistance. With the external resistance corresponding to OR, the machine will have very little excitation, and in fact will be very unstable unless the resistance is considerably reduced. If however the external resistance is such that the corresponding line is OB, the terminal P.D. will be a maximum, and slight changes of output current will cause a slight fall in P.D. In practice it is usual to operate the generator on the portion BC of the curve. It is also seen that the generator may fail to excite if started up on open circuit.

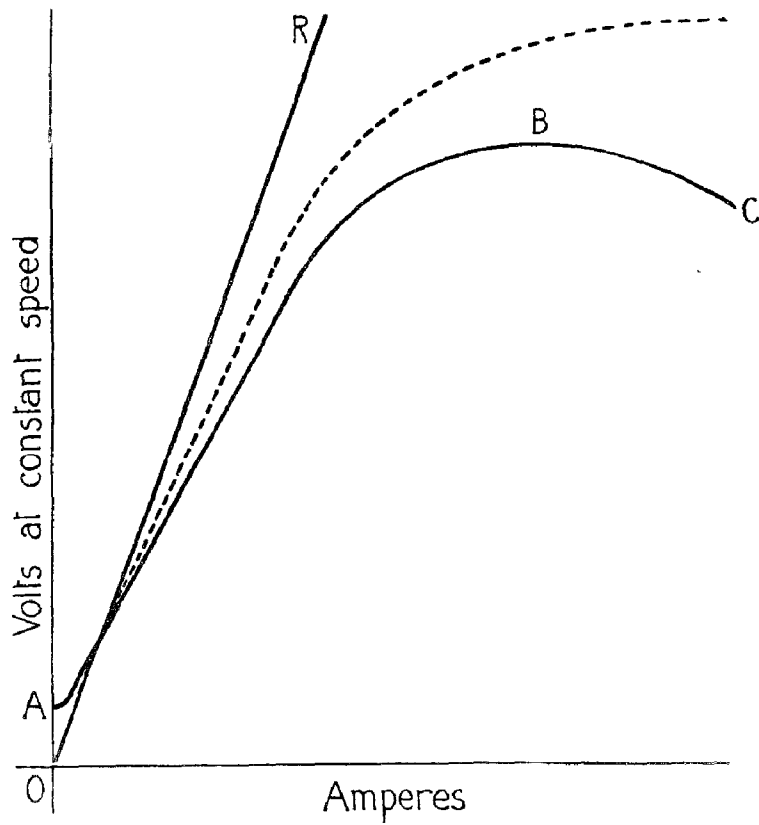

FIG. 23, CHAP. IV.—External characteristic, series-wound generator.

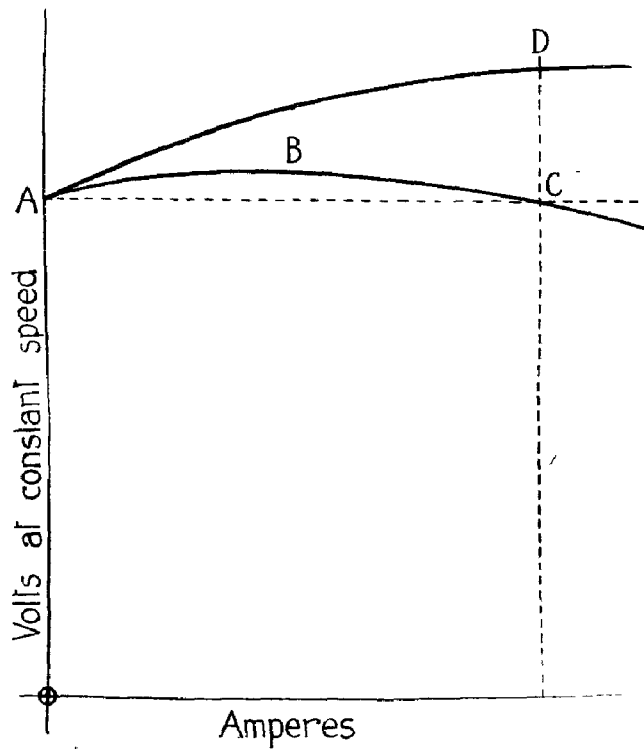

FIG. 24, CHAP. IV.—External characteristic, compound-wound generator.

**The compound-wound generator**

37. Since the effect of an increase of load is to reduce the voltage of a shunt-wound generator and to increase the voltage of a series-wound one (unless very heavy currents are taken by the external circuit), a combination of the two windings renders it possible to design a generator which will have the same terminal P.D. at full load as at no load. The external characteristic of such a generator is given in fig. 24, by the line ABC. At loads below full load the terminal P.D. will be slightly higher, and at overload, slightly lower than the P.D. at no load. The point C, which has been taken as full load, can be made to correspond with any desired current by suitably proportioning the series and shunt turns, and the machine is said to be level-compounded for this particular current. By increasing the number of series turns above that required to give level compounding, the generator may be designed to give a rising characteristic such as AD, and is then said to be over-compounded.

**Reversal of rotation**

38. If a separately excited or permanent magnet field machine is driven in the reverse direction, it generates its normal E.M.F., but its polarity will be reversed. If a shunt-wound generator is rotated in the reverse to its normal direction, however, the machine will fail to excite, for the initial E.M.F., which is set up by the residual magnetism, will be reversed, and a current will flow in the field winding which will annul the residual flux instead of increasing it. In order to cause the machine to generate when rotated reversely, the connections between field windings and brushes must be reversed, or alternatively the brush rocker must be shifted through one pole pitch. This applies also to series and compound machines.

**Reversal of polarity**

39. As the polarity of both series- and shunt-wound machines is dependent solely upon the polarity of the residual magnetism, no change of connections is necessary to cause a reversal of polarity. All that is necessary is to supply the field winding with current from some external source, ensuring that the residual magnetism is entirely reversed. On running the machine in the usual way the E.M.F. will then build up with its new polarity. This principle is of importance because it has a bearing upon the consequences of an accidental reversal of current in the circuit, e.g. if the external circuit contains a source of E.M.F. circumstances may arise in which the latter becomes greater than the voltage generated, and the direction of the armature current would then be reversed. In a series-wound generator, the field current will also be reversed, and hence the polarity will be changed. The external and generated E.M.F.'s are then in the same direction and excessive currents will flow, almost certainly causing damage. In a shunt-wound generator, however, the direction of the field current will not be reversed and the two E.M.F.'s remain in opposition. The armature current will therefore not be excessive, and on the removal of the excessive external E.M.F., the currents will resume their original directions. The external E.M.F. alluded to may be a bank of accumulators under charge, and it will be seen that the shunt generator is suitable for this purpose. The series generator cannot be used for accumulator charging without complicated switch gear, because it will not excite on open circuit. The compound generator is unsuitable for battery charging owing to the possibility of the above effect taking place, due to the influence of the series turns.

**Losses in D.C. generators**

40. The various power losses which occur may be divided into—

- (i) Copper losses, due to the electrical resistance of the windings, both field and armature.
- (ii) Iron losses, due to hysteresis and eddy currents.
- (iii) Mechanical losses, due to friction between (a) shaft and bearings, (b) commutator and brushes, (c) the rotating armature and the surrounding air. The latter is often called the "windage loss".

**CHAPTER IV.—PARAS. 41-42**

The copper losses can be calculated if the resistance of the various windings and the current carried by them is known, e.g. the field winding copper loss is  $I_f^2 R_f$  where  $I_f$  is the field current and  $R_f$  the resistance of the field winding.  $R_f$  should be measured when the winding has reached its working temperature. The iron and friction losses cannot be calculated easily or accurately, but it is possible to measure the total losses, and the iron losses may then be obtained from these by deducting the calculated copper loss. The efficiency of a generator is the ratio  $\frac{\text{power output of the machine}}{\text{power supplied}}$ . It is obviously less than unity but is generally expressed as a percentage, i.e. multiplied by 100.

41. It is usual to distinguish between three different efficiencies, known as

- (i) the commercial efficiency, which is the ratio  $\frac{\text{power in the external circuit}}{\text{power supplied by the mechanical source}}$
- (ii) the electrical efficiency, which is the ratio  $\frac{\text{power in the external circuit}}{\text{power in external circuit} + \text{copper losses}}$
- (iii) the mechanical efficiency, which is the ratio  $\frac{\text{power in the external circuit} + \text{copper losses}}{\text{power supplied by the mechanical source}}$ .

The manner in which the total input power is dissipated is shown in the following table :—

$$\text{Power input} = \text{B.H.P.} \times 746.$$

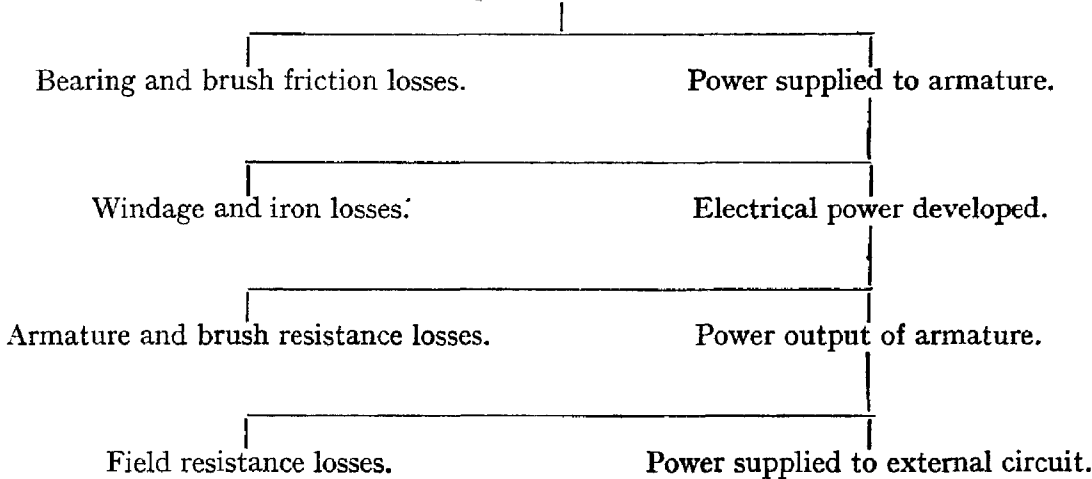

Provided that certain data are known the efficiencies may be calculated in the manner explained below.

42. The quantities which can be directly measured are (i) the H.P.  $P_M$  supplied to the generator, (ii) the terminal voltage  $V$ , (iii) the current output ( $I$ ), (iv) the resistances of the armature ( $R_A$ ) and field-winding ( $R_f$ ). The efficiencies are expressed in terms of these known quantities.

Let the generated E.M.F. be  $E$  volts, the armature current  $I_A$  and the field current  $I_f$ .

In a series-wound generator  $I_A = I_f = I$ , while  $E = V + I(R_A + R_f)$ . The following relations then hold :—

$$\text{Total watts generated} = VI + I^2 (R_A + R_f).$$

$$\begin{aligned} \text{Mechanical power supplied} &= P_M \text{ (H.P.)} \\ &= P_M \times 746 \text{ watts.} \end{aligned}$$

$$\text{Watts supplied to external current} = VI.$$

$$\text{Hence the mechanical efficiency} = \frac{VI + I^2(R_A + R_F)}{P_M \times 746}$$

$$\text{The electrical efficiency} = \frac{VI}{VI + I^2(R_A + R_F)}$$

$$\text{The commercial efficiency} = \frac{VI}{P_M \times 746}$$

In a shunt-wound generator  $I_A = I + I_F = I + \frac{V}{R_F}$  while  $E = V + I_A R_A = V + R_A \left( I + \frac{V}{R_F} \right)$  and the corresponding relations are:—

$$\begin{aligned} \text{Total watts generated} &= EI_A \\ &= \left\{ V + R_A \left( I + \frac{V}{R_F} \right) \right\} \left\{ I + \frac{V}{R_F} \right\} \\ &= V \left( I + \frac{V}{R_F} \right) + R_A \left( I + \frac{V}{R_F} \right)^2 \\ \text{Mechanical efficiency} &= \frac{V \left( I + \frac{V}{R_F} \right) + R_A \left( I + \frac{V}{R_F} \right)^2}{P_M \times 746} \\ \text{Electrical efficiency} &= \frac{VI}{V \left( I + \frac{V}{R_F} \right) + R_A \left( I + \frac{V}{R_F} \right)^2} \\ \text{Commercial efficiency} &= \frac{VI}{P_M \times 746} \end{aligned}$$

43. *Examples.*—(i) What horse-power is required to drive a 250 kilowatt dynamo when it is developing its full power, if the commercial efficiency at full load is 92 per cent. ?

$$\begin{aligned} \frac{92}{100} &= \frac{250,000}{P_M \times 746} \text{ watts} \\ \therefore P_M &= \frac{250,000}{746} \times \frac{100}{92} \\ &= 364 \text{ H.P.} \end{aligned}$$

(ii) A shunt-wound generator is supplying 250 amperes at 440 volts terminal P.D. Armature winding = 0.058 ohm, shunt winding = 81.7 ohms. Determine the armature current, the generated E.M.F. and the electrical efficiency.

$$\text{Field current} = \frac{440}{81.7} = 5.4 \text{ amps.}$$

Armature current = 255.4 amperes.

Total E.M.F. = 440 + 255.4 × 0.058.

$$= 440 + 14.8$$

$$= 454.8 \text{ volts}$$

$$\begin{aligned} \text{Electrical efficiency} &= \frac{440 \times 250}{454.8 \times 255.4} \\ &= 94.7 \text{ per cent.} \end{aligned}$$

#### CHAPTER IV.—PARA. 44

(iii) If the friction and iron losses together are 3 per cent. of the output, find the commercial efficiency of the above generator.

$$\text{Output} = 440 \times 250 \text{ watts.}$$

$$\begin{aligned} \text{Friction and iron losses} &= \frac{3}{100} \times 440 \times 250 \\ &= 3 \times 44 \times 25 \text{ watts} \\ &= 3 \times 11 \times 100 \text{ watts} \\ &= 3,300 \text{ watts} \end{aligned}$$

$$\begin{aligned} \text{Input power} &= 454.8 \times 255.4 + 3,300 \\ &= 116,000 + 3,300 \\ &= 119,300 \text{ watts} \end{aligned}$$

$$\begin{aligned} \text{Output power} &= VI = 440 \times 250 \\ &= \frac{440,000}{4} = 110,000 \end{aligned}$$

$$\begin{aligned} \text{Commercial efficiency} &= \frac{110,000}{119,300} \\ &= 92 \text{ per cent.} \end{aligned}$$

#### Direct current motors

44. Any dynamo-electric generator can be used as an electric motor, that is, if the machine is supplied with electrical energy it will convert a proportion of it into mechanical energy. This is the reverse of its action as a generator when it receives mechanical energy, a portion of which is converted into electrical energy. The action of a motor depends upon the force exerted between a magnetic field and a current-carrying conductor (Chapter II). It has been shown that the mutual force between the field and the conductor is equal to  $\frac{BI}{10}$  dynes per centimetre, where  $B$  is the flux density of the field and  $I$  is the current in the conductor, in amperes. If the flux is fixed in space and the conductor is free to move the direction of motion of the latter is given by the left hand rule. In an actual wound armature as described above, all the conductors under one pole carry currents in the same direction, while all those under an opposite magnetic pole carry currents in the reverse direction. All the forces exerted tend to rotate the armature in the same direction, and a continuous electro-dynamic torque is maintained.

*Examples.*—(i) A conductor 50 centimetres in length carrying a current of 10 amperes is situated in a field in which  $B = 10,000$  gauss. Find the force exerted upon it, in pounds.

$$\begin{aligned} f &= \frac{BI}{10} \text{ dynes} \\ &= \frac{10,000 \times 50 \times 10}{10} = 500,000 \text{ dynes} \\ &= \frac{500,000}{981} \text{ grams} \\ &= \frac{500,000}{981 \times 453} \text{ lb.} \\ &= 1.125 \text{ lb.} \end{aligned}$$

(ii) Find the torque in pounds-feet on an armature having 2,000 conductors, each carrying 25 amperes, the diameter of the armature being 1 metre, its length 0.5 metre, and the flux density in the airgap 5,000 gauss. Assume that the poles embrace 70 per cent. of the surface of

the armature. The number of conductors situated in the field is 70 per cent. of the total or  $\frac{70 \times 2,000}{100} = 1,400$ . Each of these carries  $\frac{100}{4}$  amperes, and the total ampere-conductors is  $1,400 \times \frac{100}{4} = 35,000$ . The total force acting on all the conductors is  $\frac{BILN}{10} = 5,000 \times 50 \times \frac{35,000}{10}$  dynes.

$$= \frac{5,000 \times 50 \times 3,500}{981 \times 453} \text{ lb.}$$

$$= 1,970 \text{ lb.}$$

The torque or turning moment is the force multiplied by the radius on which it is exerted. The radius is 0.5 metre = 50 centimetres =  $\frac{50}{2.54 \times 12}$  feet.

$$\text{Torque} = \frac{50}{2.54 \times 12} \times 1,970 \text{ pounds-feet}$$

$$= 3,220 \text{ pounds-feet.}$$

**Back E.M.F. and armature reaction**

45. When the armature is in rotation, its conductors cut the flux, and an E.M.F. is induced in them, exactly as is the case when the rotation is caused by some external source of energy. By Lenz's law this induced E.M.F. is in such a direction that it opposes the force which produces it, and as the rotation is caused by the current flowing in the armature conductors, the induced E.M.F. is in opposition to the applied E.M.F. and is generally referred to as the "back E.M.F.". In any given machine, running as a motor, the back E.M.F. has the value which the generated E.M.F. would have if the machine were driven mechanically, i.e. as given by the formulae of paragraph 25, hence the back E.M.F. varies directly as the speed of the machine. Now we have seen that in the motor, the electro-dynamic torque causes rotation, whereas the effect of the back E.M.F. is to reduce the armature current and therefore to decrease the torque. Friction and air resistance also oppose rotation, and the torque available to cause acceleration of the armature decreases as the speed increases. At some particular speed the driving torque is exactly equal to the torque opposing motion, and the armature receives no further acceleration, but continues to run at this steady speed. As in the generator, the flux caused by the armature currents combines with the stator flux to produce a resultant field which is not symmetrical about the geometrical neutral axis, but as the current is flowing in the opposite direction to the generated (i.e. back) E.M.F. the magnetizing effect of the armature windings is opposite to that in a generator, and the total magnetic field is distorted against the direction of rotation. The brushes must be given a lag or trail to obtain satisfactory commutation, unless inter-poles are used for this purpose. It is seen on reflection that if inter-poles are used to obtain sparkless commutation, any inter-pole must have the polarity of the main pole which is behind it in the direction of rotation.

**Motor characteristics**

46. Any form of field excitation may be used for a motor, and the behaviour of the various forms of motor may be compared by means of their mechanical characteristics, the latter being curves showing the relation at constant supply voltage between the speed and the torque. It is desirable to bear in mind that the back E.M.F. is normally very nearly equal to the applied E.M.F. and so is nearly constant. As  $E_b = K n \Phi$  the product  $n \Phi$  is very nearly constant, or the speed  $n$  varies (approximately) inversely as the flux.

**Shunt-wound motor**

47. The mechanical characteristic of this type is shown in fig. 25. The field current is constant because the terminal P.D. is constant. It is seen that as the torque is increased the

## CHAPTER IV.—PARA. 48

speed falls, because the increase of torque is due to an increased demand for mechanical power, i.e. an increase of mechanical load, and therefore an increase of armature current, which can only be obtained by a decrease of back E.M.F., and consequently a lower speed. Shunt-wound motors are suitable for driving machine tools and motor-generators.

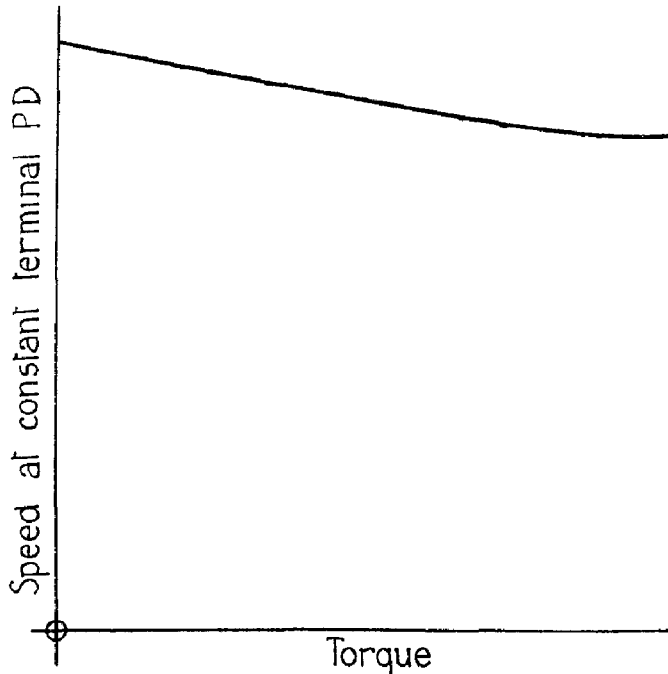

FIG. 25, CHAP. IV.—Mechanical characteristic of shunt-wound motor

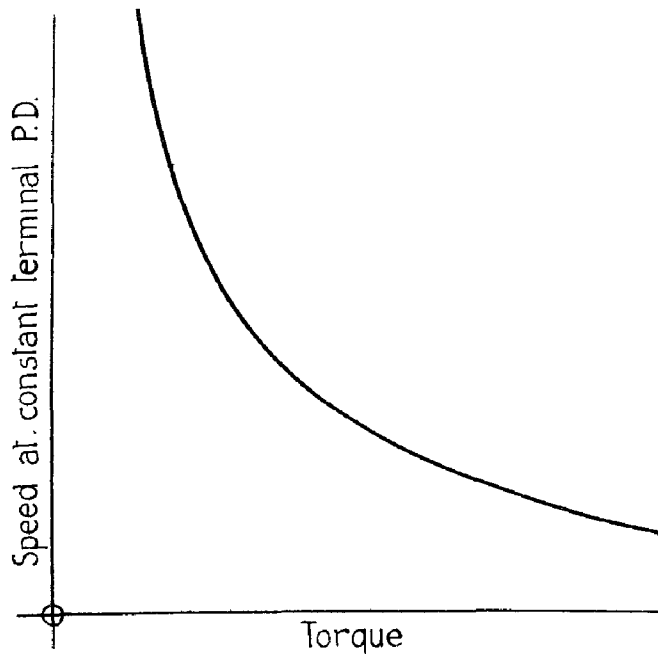

FIG. 26, CHAP. IV.—Mechanical characteristic of series-wound motor.

### Series-wound motor

48. The mechanical characteristic is shown in fig. 26. In this machine an increase of torque calls for an increase of armature current as usual, but as this current also flows through the field

winding, the field is strengthened and the speed decreases. Series motors are suitable for traction purposes, because they exert their greatest torque at low speeds, i.e. when starting. As the load decreases they increase speed automatically. They are also adapted for hoisting purposes, for while a shunt-wound motor would raise any load whatever at practically the same speed, a series motor will raise a light load at high speed, but a heavy load at low speed. Series motors should not be used in circumstances where the load can be totally removed, for there is then a danger that the speed may become excessive and cause damage to the armature by the large centrifugal forces then developed. Fans are generally driven by series motors.

**Compound-wound motors**

49. A motor having both series and shunt field windings may have them connected in either of two ways. If their magnetizing effects are in the same direction, i.e. if the series and shunt currents flow in the same direction round the pole, the machine is said to be cumulatively wound while if the series and shunt currents are in opposition the machine is said to be differentially wound. In the latter type the series turns may be made to weaken the field by an amount just sufficient to make the speed at some particular load the same as at no load. The speed at other loads will then be slightly different, the mechanical characteristic being somewhat as shown in fig. 27a. This type of motor is rarely used. When a compound-wound motor is referred to without qualification the cumulative type is implied. The mechanical characteristic, fig. 27b, is intermediate between those of the shunt and series motors. This type of machine is used where a series characteristic is desired, e.g. for hoisting purposes, but where the load may be entirely removed on occasion. The effect of the shunt winding is to prevent a dangerous increase of speed when this occurs.

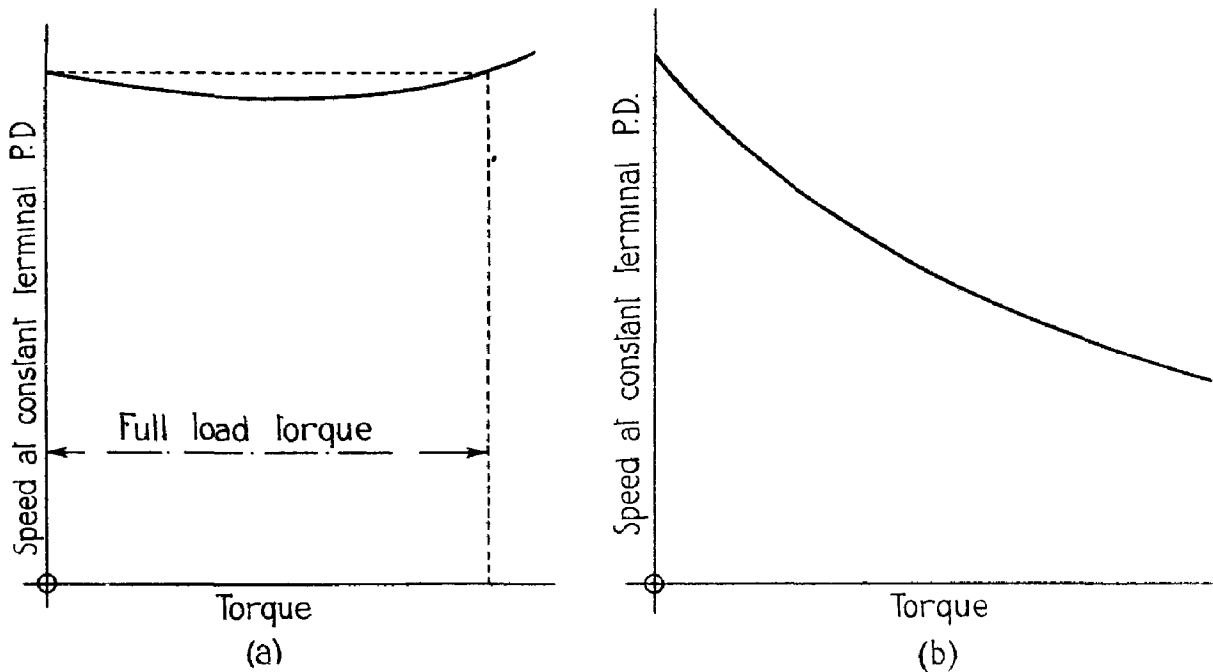

FIG. 27, CHAP. IV.—Mechanical characteristics, compound-wound motors.

**Losses in motors**

50. The various losses which occur in electric motors are identical with those which occur in generators, i.e. copper losses, iron losses and frictional losses. The commercial efficiency is the ratio  $\frac{\text{power obtained from the motor}}{\text{electrical power supplied}}$ , both numerator and denominator being expressed in watts.

## CHAPTER IV.—PARAS. 51-52

The electrical efficiency is the ratio  $\frac{\text{mechanical power developed by armature}}{\text{electrical power supplied}}$ , and the mechanical efficiency is the ratio  $\frac{\text{power obtained from motor}}{\text{mechanical power developed in armature}}$ . As before the power balance sheet may be shown in tabular form thus :—

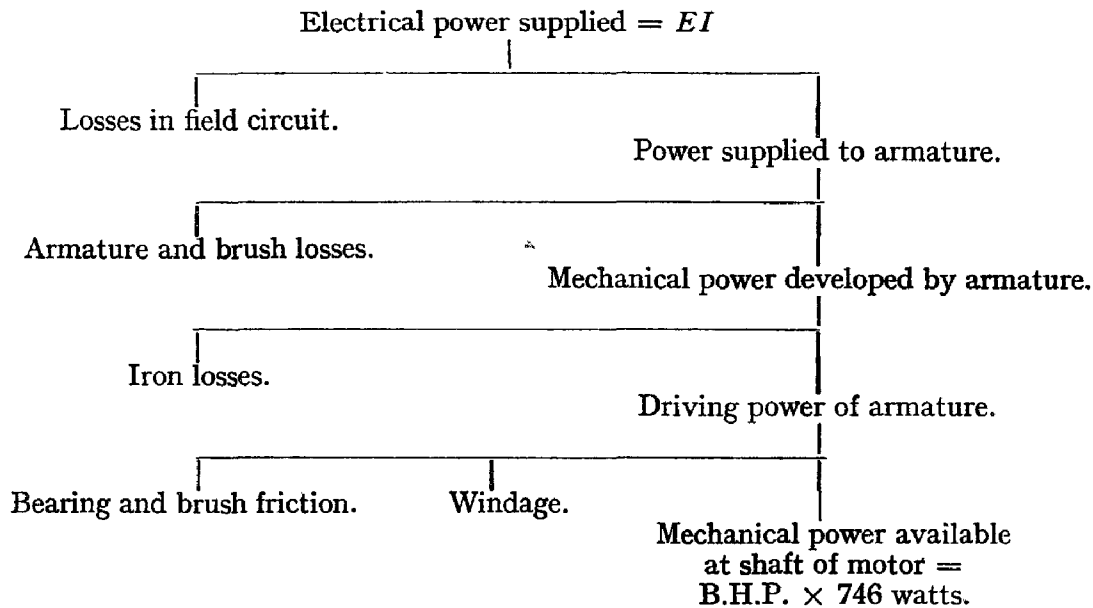

### Motor starters

51. When the armature of a motor is at rest it obviously develops no counter-E.M.F. and if it were switched directly on to the mains, an extremely large current would flow, causing serious damage to the machine. Thus, a 10 H.P. series-wound 220-volt motor may have a normal full load current of about 40 amperes, an armature resistance of 0.2 ohm, and a field resistance of 0.1 ohm. If directly connected to the mains, the initial current would be  $\frac{220}{0.3} = 733$  amperes which is practically twenty times the normal full load current, and would almost certainly do serious damage to the armature. To avoid this a series starting resistance is used, this resistance being cut out step by step as the speed of the motor, and the counter-E.M.F., increases. Small series motors usually have a field winding of sufficiently high resistance and inductance to render the use of a starting resistance optional.

### Shunt motor starter

52. In all except the smallest sizes a starting resistance is essential for a shunt motor, because the field winding is in parallel with the armature, hence the latter would be thrown straight on the supply mains if a simple make-and-break switch were employed; owing to the extremely low resistance, a very heavy current would then flow through the windings and would cause severe damage. This starter also generally embodies two safety devices known as the overload release and no-volt release respectively. The general features of a shunt motor starter designed for manual operation is shown in fig. 28. The moving arm (A) which is normally held in the off position by a spring (S), is arranged to sweep over a row of contacts which are arranged on an arc. To these contacts are connected a series of tappings on the resistance R, which is in series with the armature only, and on moving the arm to the first contact (1) the full mains voltage is applied to the field winding, causing the field to build up to its full excitation, but allowing only a limited current to flow through the armature. This may actually be as much as double the normal running current. The armature then starts to rotate and generates a back E.M.F., the armature

current falling as the speed increases. When the armature current has fallen to its normal running value, the arm is moved to the second contact (2). The armature current again rises, but as the speed increases the additional back E.M.F. soon reduces the current to normal once more. The operation is repeated in this manner until the whole of the resistance is cut out and the armature is then connected straight across the supply mains. When the arm is in its final position it is held in place by an electro-magnet acting upon a "keeper" which is attached to the moving arm, and the spring (S) is arranged to pull the arm back into the "off" position should the current through the field winding fail. The winding of this electro-magnet is connected in series with the field winding. This electro-magnet is called the no-voltage release; its inclusion ensures (i) that the switch arm will return to its off position should the supply voltage fall below a certain value, and (ii) that the motor will be switched off automatically in the event of a break occurring in the field circuit of the machine. The latter precaution is necessary because otherwise, the sudden weakening of the field would cause the motor to increase in speed to a dangerous extent. The overload release or overload cut-out is an electro-magnet the winding of which is directly in series with the supply. A piece of soft iron which is pivoted at one end is so arranged that when attracted by this electro-magnet, it short-circuits the no-voltage release coil, and the starter arm is allowed to fall back to the "off" position. The armature of the overload coil is normally held off its contacts by a small spring, the tension of which is just overcome by a given overload.

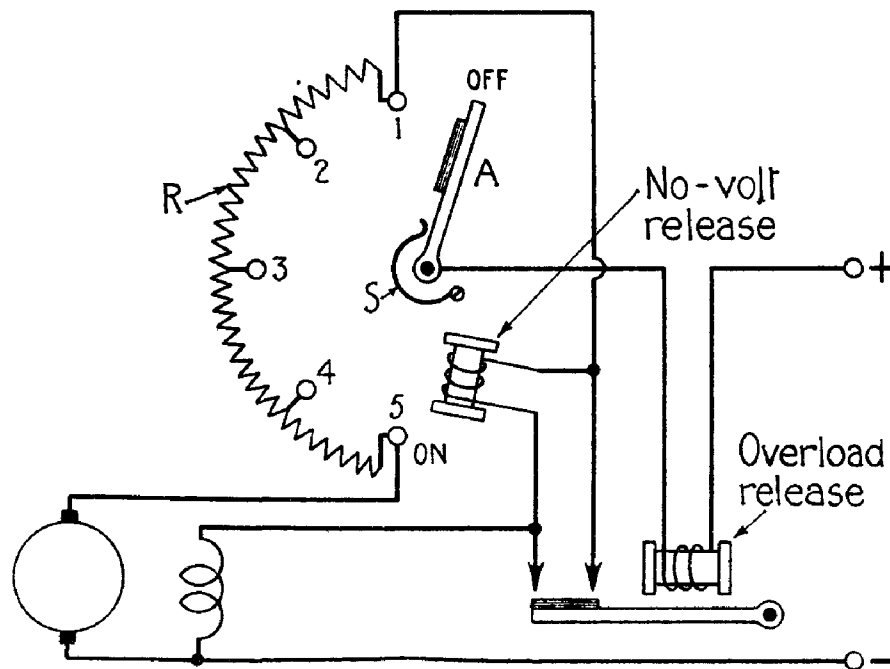

FIG 28, CHAP. IV.—Shunt motor starter.

### Voltage transformation

53. It frequently happens that the voltage required for a certain purpose differs from that which is immediately available. If the latter is higher than the required voltage, a simple expedient is to insert an appropriate resistance in series with the low voltage appliance, so that the correct voltage is applied to the terminals of the latter. The wastefulness of this procedure is not always appreciated, and an example may be of assistance to the reader. Consider the charging of a large capacity secondary battery from 220-volt mains. The nominal voltage of the battery being 20 volts, i.e. 10 cells, we will assume that it has fallen to 1.8 volts per cell or 18 volts, and the internal resistance of the battery to be 0.1 ohm, while its charging rate is 10 amperes. The necessary value of series resistance to give the desired charging current is found by Ohm's law,

CHAPTER IV.—PARA. 53

$$I = \frac{E - E_b}{R}$$

where  $I$  is the charging current,  $E$  the supply voltage,  $E_b$  the E.M.F. of the battery and  $R$  the required resistance. Transposing and inserting numerical values

$$R = \frac{220 - 18}{10} \\ = 20.2 \text{ ohms.}$$

Now consider the electrical efficiency of the charging process. The power supplied is  $E I$  watts, the power converted into heat is  $I^2 R$  watts and the efficiency is  $\frac{E I - I^2 R}{E I}$  or  $\frac{E - IR}{E}$  which is  $\frac{220 - 202}{220} = \frac{18}{220}$  or 8.16 per cent. Of the cost of charging the battery during the whole period of service, elevenpence in every shilling is wasted, and the wastage can only be avoided by adopting some method of changing the voltage, from that of the supply to that actually required. When the supply consists of direct current and voltage, this change of voltage can be achieved by the use of either a motor generator or by some form of booster. Although the use of a series resistance enables a reduction of voltage to be obtained at the terminals of any apparatus, the use of some form of rotating machinery is essential when an increase of voltage is desired. In this respect alternating supply enjoys a considerable advantage over direct supply, for by means of a suitable A.C. transformer, which has no rotating parts and requires a minimum of attention, the voltage can be raised or lowered as may be most desirable.

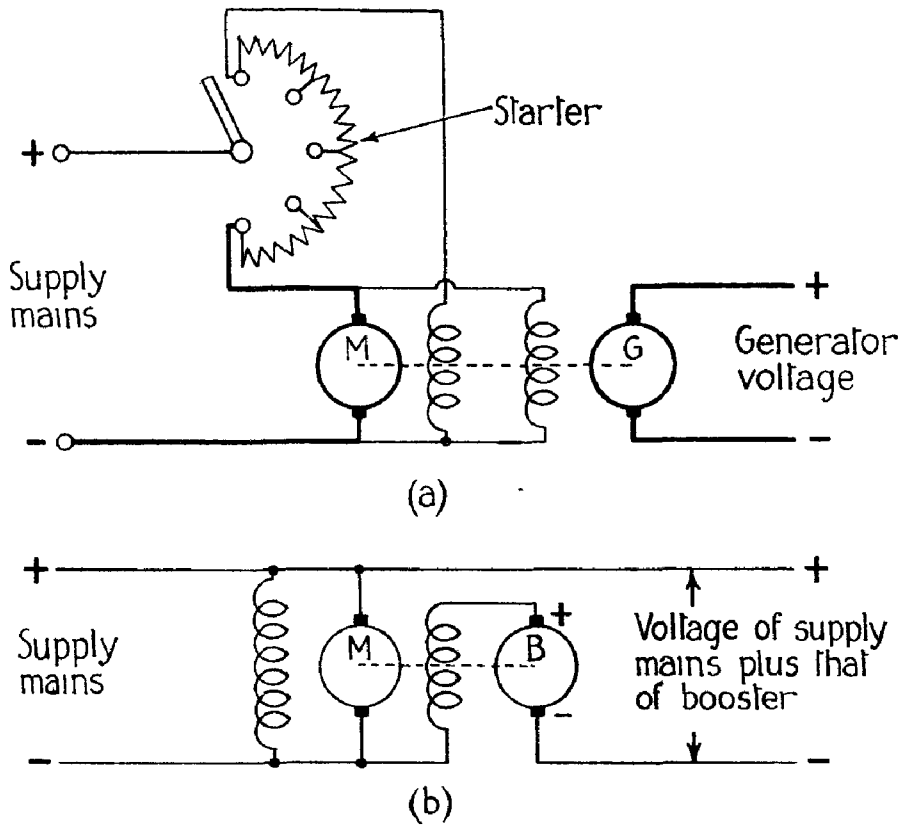

FIG. 29.—Motor generator and booster.

**The motor generator**

54. This consists of a motor running off the supply mains, which drives an electrical generator providing power at the desired voltage. In its simplest form the machine comprises separate motor and generator the shafts of which are coupled together, the two machines being mounted on a common bed plate. The motor is invariably shunt-wound, and the field excitation for the generator is provided from the supply. The connections to the input and output terminals are therefore as shown in fig. 29a. This type of motor generator has the advantage that the generated voltage can be controlled by variation of the generator field excitation independently of the speed of rotation, which is controlled by the motor field. Double-wound motor generators are those which carry two separate windings on the same armature core, each winding having its own commutator. It is convenient to mount one of these at each end of the armature. One winding is connected through its commutator and brush gear with the supply mains, and drives the armature as a motor, while the other winding is designed to give the desired voltage. Field excitation is supplied from the mains. The double wound machine is lighter and smaller than the separate unit motor generator, and its cost is rather lower, while the effects of armature reaction are not so pronounced, owing to the opposing reactions of the two windings. On the other hand, the generator voltage cannot be controlled by variation of the field excitation, because if the field is weakened with a view to reducing the voltage, the machine considered as a motor will increase speed, and the voltage will increase also. This disadvantage prevents the extensive adoption of the double-wound machine.

55. A booster is a generator, the voltage of which can be added to that of another generator, thus increasing the total voltage. The machine is primarily merely a motor generator, but the output voltage of the generator is connected in series with the supply voltage, the simplest arrangement being given diagrammatically in fig. 29b, from which it is apparent that the terminal voltage of the booster is the sum of that generated by the machine and that of the supply. If a reduction of voltage is required, the booster field is connected in such a manner that the E.M.F. of the booster armature is in opposition to that of the mains. These machines have little service application.

This file was downloaded  
from the RTFM Library.

Link: [www.scottbouch.com/rtfm](http://www.scottbouch.com/rtfm)

Please see site for usage terms,  
and more aircraft documents.

