

CHAPTER 1

LINEAR CIRCUIT ANALYSIS

1. INTRODUCTION

This chapter summarises those items of conventional electric circuit theory which form the basis of the analysis in the remainder of Part II. It consists largely of statements of results, and other texts should be consulted if proofs are required. For present purposes the circuit is regarded as a collection of components (or circuit elements) interconnected by a mesh of short conductors and stimulated electrically at localised places, the whole assembly being so compact that electromagnetic effects can be assumed to be propagated instantaneously within this self-contained system. The behaviour of the circuit is described primarily in terms of the potential differences existing between pairs of "points" in the circuit and of the currents which flow through "points" in the circuit; the word "point" here usually signifies the cross-section of a conductor.

The symbol for a potential difference (or voltage) is v , and that for a current is i .

The subject matter of this chapter is dealt with in the following standard Service Reference Books :-

Admiralty Handbook of Wireless Telegraphy	Vol. 1.
(BR 229)	
Signal Training (26/Manuals/1451 and 1577)	Vol. II Parts I and II.
Royal Air Force Signal Manual	Part II.
(AP 1093)	

References to particular passages are given in the appropriate sections of this chapter.

In particular the matter of Sec. 12 should be taken as supplementing, not replacing, the description given in the standard Service Reference Books. The appropriate references are :-

BR 229. Chap. V. (Paras. 272-348).
26/Manuals/1451. Chap. XXV. (Secs. 231-240).
26/Manuals/1577. Chaps. II and III. (Secs. 9-17).
AP 1093. Chap. V.

2. CIRCUIT LAWS AND CONVENTIONS

Circuit theory is founded on two laws attributed to Kirchhoff. One governs the relations between currents and the other the relations between potential differences in a circuit. These laws may be stated as follows :-

- (i) The algebraic sum of the currents entering a point is zero at any instant.
- (ii) The algebraic sum of the potential differences encountered in traversing a closed loop is zero at any instant.

Chap. 1, Sect. 2

Thus in Fig. 1, application of the first law with regard to the currents $i_1, i_2 \dots i_7$ provides the following independent relations :-

$$(i) \begin{cases} i_1 - i_2 - i_4 + i_7 = 0 \\ i_2 + i_3 - i_5 - i_7 = 0 \\ i_1 + i_3 - i_6 = 0 \end{cases}$$

Similarly the second law, applied in respect of the potential differences $v_1, v_2 \dots v_{10}$, provides the following independent relations :-

$$(ii) \begin{cases} v_1 - v_4 - v_7 - v_9 = 0 \\ v_2 - v_5 - v_{10} = 0 \\ v_3 - v_6 - v_8 - v_9 = 0 \\ v_7 - v_8 + v_{10} = 0 \end{cases}$$

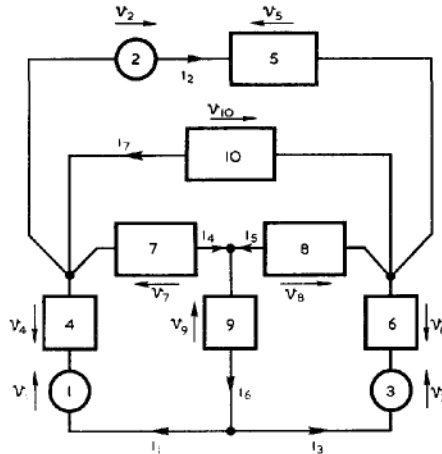

Fig. 1 - Typical circuit containing active and passive elements.

Although other similar relations may be available they will be found to be implicit in those stated.

In the diagram three types of circuit elements are indicated:

- (a) a thin line denoting an ideal connector between other elements, and providing no impediment to the current;
- (b) a rectangular box denoting a passive element, i.e. one which normally impedes the current, and
- (c) a circular box denoting an active element, i.e. one which normally drives the current.

The directions of reference for currents and potential differences are indicated by arrows; those for the potential differences are alongside the elements to which they refer, the tip of an arrow being taken to indicate the terminal of higher potential, and those for the currents are superimposed on the connectors, their direction indicating the flow. (This is the opposite direction to that of the movement of the electrons). It is emphasised that these directions are solely for reference and correspond with actual voltages and currents only when these emerge from the analysis with positive values. It may be noticed that in a simple circuit having only one generator the voltage arrow appears to assist the current arrow through the active element, and to oppose it through passive ones, although this useful relation is only a consequence of the above conventions.

Any closed path in a network is known as a Mesh, and the application of Kirchhoff's laws can be simplified by using the conception of Mesh Current Components to replace currents through the elements. Fig. 2 represents the same circuit as Fig. 1 when redrawn from this point of view; (the voltage arrows are omitted for the sake of clarity). The current in any direction through a circuit element is the algebraic sum of the components in that direction contributed by those meshes of which it forms a part. Thus, by a comparison of Figs. 1 and 2 the following relations emerge :-

$$\begin{aligned}
 i_1 &= i_A \\
 i_2 &= i_B \\
 i_3 &= i_C \\
 i_4 &= i_A + i_D \\
 i_5 &= i_C - i_D \\
 i_6 &= i_A + i_C \\
 i_7 &= i_B + i_D
 \end{aligned}$$

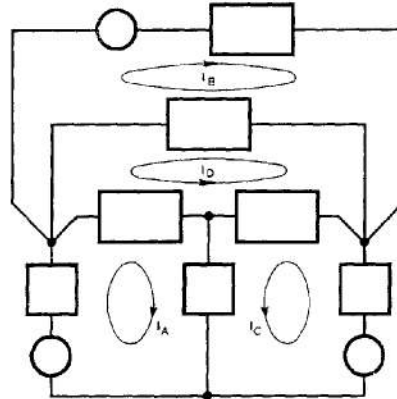

Fig. 2 - Circuit showing mesh currents.

These will be found to satisfy equations (i), and signify that by the introduction of mesh current components Kirchhoff's first law is automatically satisfied and the number of variables reduced. The components also simplify network analysis for other reasons; but it should be remembered that they exist only as a convenience in analysis, and cannot be endowed with a separate physical existence in circuits.

Substitution Theorem

This useful theorem, of general application, is self-evident, and may be stated as follows :-

A part of any network, coupled to the remainder only through its terminals, may be replaced without affecting the behaviour of the remainder of the network by a system of ideal generators of voltage (or current) which are arranged so as to preserve the previously existing potential differences (or currents) at the terminals. (The conception of an ideal generator of voltage (or current) is considered in Sec. 4.)

References :

- BR 229. Paras. 72 and 73.
- 26/Manuals/1451 Sec. 136.
- AP 1093. Chap. 1. Paras. 31-38.

CHARACTERISTICS OF CIRCUIT ELEMENTS

3. Passive Elements

Circuit problems cannot be solved simply from a knowledge of circuit laws; it is also necessary to know the characteristic properties of each element in the circuit so as to be able to predict its behaviour when subjected to any specific variation of voltage or current. Although such properties may on occasion be very complicated, and expressible only in the form of experimental data, tabulated or presented by means of graphs, there is a wide range of elements for which much simpler specification is available. Thus it is found that for one class of circuit elements the current i is always proportional to the applied voltage v . Where this obtains the elements are described as resistive (or purely resistive) and are known as resistors. The ratio $\frac{v}{i}$ is

called the resistance of the element, denoted by R . The appropriate

Chap. 1, Sect. 3.

circuit symbol is shown in Fig. 3(a). The result :-

$$\frac{v}{i} = \text{constant (i.e. R is constant)}$$

is known as Ohm's law.

For another type of element the current i is always proportional to the rate of change of the applied voltage, $\frac{dv}{dt}$. Such

elements are said to be capacitive and are known as condensers (or capacitors). The ratio $i/\frac{dv}{dt}$ is called the capacitance of

the element, denoted by C . The appropriate circuit symbol is shown in Fig. 3(b). The result :-

$$\frac{i}{\frac{dv}{dt}} = \text{constant}$$

(i.e. C is constant)

has no particular name; it is the law for a condenser, and is usually quoted in the form

$$\frac{q}{v} = C$$

where q is the charge on one plate.

For yet another type of element the applied voltage is always proportional to the rate of change of current, $\frac{di}{dt}$. Such elements are

said to be self-inductive, and are known as coils (or self-inductors). The ratio $v/\frac{di}{dt}$ is called the self-inductance (or simply the inductance)

of the element, denoted by L . The appropriate symbol is shown in Fig.3(c).

So far all elements considered have had one pair of terminals; but there is another type of inductive element with two pairs, having the property that if the current through one pair (primary) varies, then a voltage is established between the other pair (secondary), which, on open circuit, is always proportional to the rate of change of the primary current. Such elements are known as transformers (mutual inductors) and the ratio $\frac{v \text{ (secondary)}}{\frac{di}{dt} \text{ (primary)}}$ is called the mutual inductance, denoted by M . The

appropriate symbol is shown in Fig. 3(d).

These last two results, of the form

$$\frac{v}{\frac{di}{dt}} = \text{constant (i.e., L or M is constant)}$$

are a consequence of Faraday's Law of Electromagnetic Induction, which states that the induced EMF is proportional to the rate of change of the flux turns threading a circuit.

Actually no elements conform exactly and under all circumstances to the ideal concepts of resistance, capacitance and inductance

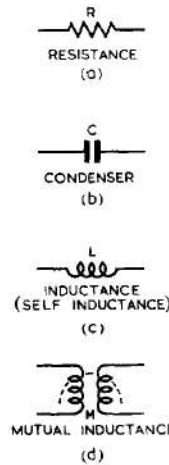

Fig. 3 - Circuit symbols

which have been defined, though some may do so nearly enough for practical purposes within a more or less restricted range of circumstances. Other elements may exhibit behaviour which can be simulated by combinations of ideal elements, the degree of simulation increasing with the complexity of the "equivalent network". Thus in Figs. 4(a) and (b) are shown three successive approximations to simulate the properties of a coil of wire and of a condenser, respectively. It should be clearly understood that such representations serve a most useful purpose as equivalents, but that identification of parts of the representation with parts of the component represented is by no means always permissible, and that such points in the equivalent circuit as the junctions of R and L in Fig. 4(a) have no physical existence.

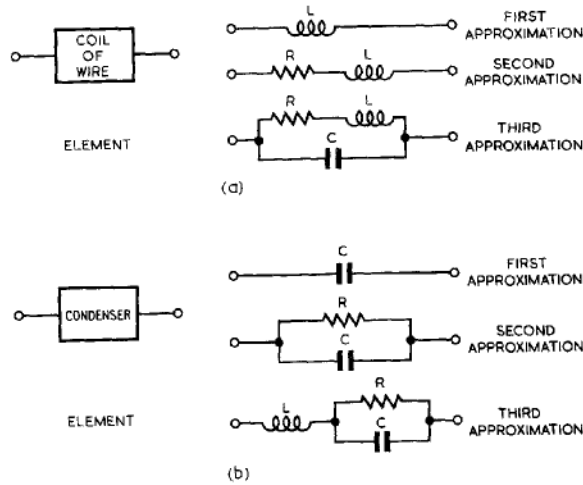

Fig. 4 - Equivalent networks : successive approximations.

Circuit elements which may be represented adequately by an equivalent network made up of unvarying resistance, inductance and capacitance are known as Linear Elements, and circuits whose passive elements are all linear are known as linear circuits or networks. Subject to limitations, the theory of linear circuits may also be applied to circuits in which the fundamental parameters, resistance, inductance and capacitance, are functions of applied frequency or of time: specification of these limitations is beyond the scope of the text, except to state that the more gentle the variation of parameters, as compared with the mode of exciting the circuit, the more accurate is the analysis.

References

- BR 229. Paras. 58-68 and 128-183.
- 26/Manuals/1451. Secs. 127-133, 185-202 and 60-72.
- AP 1093. Chap. 1. Paras. 26-30 and 47-58.
- Chap. 2. Paras. 24-43.

4. Active Elements

Active circuit elements are primarily sources of electromotive-force and are ultimately responsible for all the electrical behaviour displayed by actual circuits. The voltage developed at the terminals of an active element is not the same in general as the EMF generated, the difference between these quantities being ascribed to losses in the element itself and arising from internal impediments to the current established.

For a comprehensive circuit analysis it is therefore necessary to know the voltage which would be developed at the terminals of each particular generator under all conditions of load.

Just as it has been found convenient to describe the properties of a passive element in terms of an equivalent network, so it is helpful to replace an active element by an equivalent combination of elements in which the primary action (generation of EMF) is ascribed to an ideal active element, devoid of loss, associated with a passive element, representing the internal impediment; (see Fig. 5). For many practical active elements the internal impediment may be represented by a linear network, and further, the characteristics of the ideal generator may be found to be independent of load; both of these qualifications materially simplify circuit analysis. The ideal active element of Fig. 5 may be termed a Constant Voltage Generator, as it delivers an EMF as stated under all conditions of load. An alternative equivalent representation is shown in Fig. 6, in which the ideal active element may be described as a Constant Current Generator, in that its function is to maintain a current as stated under all conditions of load.

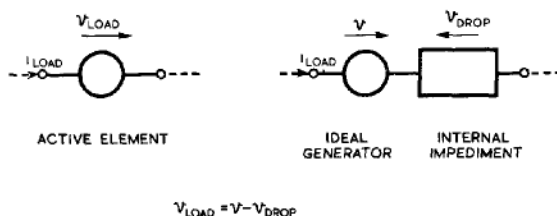

Fig. 5 - Representation of an inactive element : constant voltage equivalent network.

The idea of a constant current generator may seem rather curious to those who naturally regard potential difference as cause and current as effect. In circuit analysis, however, it is only the relations between these two quantities which have special significance, and it is not necessary to assert that either notion is more fundamental than the other. Thus the notions of ideal voltage generators and ideal current generators are equally feasible.

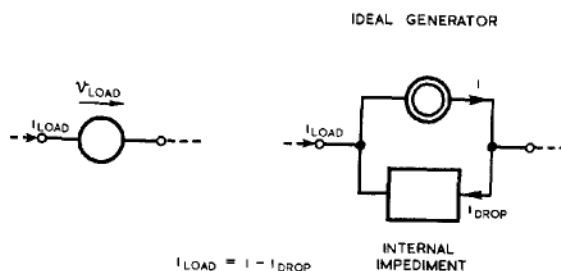

Fig. 6 - Representation of an active element : constant current equivalent network.

References

- BR 229. Paras. 49-54.
26/Manuals/1451. Sec. 117.
AP 1093. Chap. 1. Paras. 17-22.

LINEAR CIRCUITS

5. General

Linear circuits are those in which all passive elements (including those representing the internal impediments of active elements) can be represented by equivalent combinations of resistance, inductance and capacitance, i. e. circuits whose behaviour is governed by linear differential equations relating voltage and current. Circuits to which this restriction cannot be applied are generally termed Non-Linear (or Non-Ohmic), and the analysis of their behaviour is usually complicated.

Certain results hold in the field of linear circuits which do not in general permit of wider application. These are stated below in the form of circuit theorems.

6. Superposition Theorem

In a linear network the current at any point (or the potential difference between any two points) may be regarded as the algebraic sum of the corresponding currents (or potential differences) produced as each generator in the network is considered to operate independently with all the others suppressed.

To suppress a generator, in this sense, means to reduce its output to zero without affecting its internal impediment; this may be regarded as equivalent to short-circuiting the ideal voltage generator (or open-circuiting the ideal current generator) in the equivalent circuit of an active element; (see Figs. 5 and 6).

7. Reciprocity Theorem

In any passive linear network the current produced at one point as a result of inserting an ideal voltage generator at another is identical with the current which would be produced at the second point by inserting the same generator at the first. Similarly, the potential difference arising between any pair of points from bridging any other pair with an ideal current generator is identical with the potential difference which would arise between the second pair of points by bridging the first pair with the same generator.

REPRESENTATION OF SINUSOIDAL CURRENTS

AND VOLTAGES IN LINEAR CIRCUITS

8. General

Throughout this volume a capital letter (e.g. V) is used to denote any voltage or current which in the circumstances may be taken as remaining constant over the interval of time considered. Where the quantity under discussion varies it is denoted by a small letter, (e.g. v). Thus,

$$v = f(t)$$

is the relation indicating that the value of v at any instant t can be

expressed as a function of t . In the particular case of a sinusoidal function, v might satisfy the relation

$$v = \hat{v} \sin \omega t,$$

\hat{v} denoting the amplitude, or peak value, of v , and ω the angular frequency, which is $2\pi f$, where f is the frequency of the oscillatory voltage.

For the remainder of this chapter we are concerned with the analysis of linear networks which are subjected to steady sinusoidal voltages, emphasising in particular those points which are useful in subsequent chapters and which are not stressed in the references quoted. The behaviour of circuits which are not linear or which are subjected to other kinds of voltage-variations is discussed in other chapters.

The importance of the sinusoidal voltage in this field is due to the ease with which the results for all types of circuit elements can be specified in simple form. Thus, in any linear network subjected to one or more sinusoidal voltages of the same frequency the current at any point and the voltage between any two points are also sinusoidal (of the same frequency) and can be specified in terms of amplitude and phase, measured with respect to one of the generators. This form of specification also avoids an undue emphasis on the instantaneous values, which have rarely any special interest, notwithstanding the fact that they represent the actual events occurring. The commonplace existence of sinusoidal voltages gives added importance to this type of analysis.

In building up a sinusoidal analysis of circuit behaviour, the trigonometry associated with instantaneous values is commonly avoided by the use of vector representation, in which instantaneous values are regarded as the instantaneous projections of rotating vectors. Such vectors are used to represent voltages and currents, length representing amplitude and direction representing phase. Phase difference is represented exactly by difference in direction of two such vectors.

By the use of complex numbers the geometry of such vector diagrams can be expressed in algebraic form. For instance,

$$i = \hat{i} \mathcal{E} j(\omega t + \phi)$$

represents a vector diagram in which a vector of length \hat{i} , passing through the direction ϕ at zero time rotates with angular velocity ω . Now

$$\hat{i} \mathcal{E} j(\omega t + \phi) = \hat{i} \left[\cos(\omega t + \phi) + j \sin(\omega t + \phi) \right],$$

the term $\hat{i} \cos(\omega t + \phi)$, (known as the Real Part) denoting the projection on the horizontal axis, and the term $j \hat{i} \sin(\omega t + \phi)$ (known as the Imaginary Part), the projection on the vertical axis. This enables vector treatment to be translated into the actual instantaneous values at any stage by considering the real parts of the expressions for voltage and current. The use of complex numbers in expressions infers that voltage and current are also specified in similar terms, and the rewording of the results in terms of real voltages and currents is often left to the reader; this is a common practice in electrical text books.

For convenience the representation on a diagram of such a vector as

$$v = \hat{v} \mathcal{E} j\omega t$$

is denoted by an arrow, thus; \vec{v} .

References

- BR 229. Paras. 339-348
 26/Manuals/1577, Chap. II. Appendix I.
 AP 1093. Chap. V.

9. Complex Quantities

Fig. 7 represents a vector \vec{r} which is shown in relation to a pair of perpendicular axes; the horizontal axis is called the Real axis and the vertical axis the Imaginary axis. Vectors drawn parallel to the imaginary axis are prefixed with j to denote this direction. Thus \vec{a} represents a step of amount a parallel to the real axis and $j\vec{b}$ a step of amount b parallel to the imaginary axis. Combining these steps the resultant becomes $\vec{a} + j\vec{b}$ represented in the diagram by \vec{r} . Hence we can write

$$\vec{r} = \vec{a} + j\vec{b} \quad (\text{Cartesian form}).$$

In analysis the arrows are omitted, so that the expression is written

$$r = a + jb$$

Alternatively, \vec{r} is a vector of length $|r|$ making a direction θ with the real axis, and can be thought of as a vector of length $|r|$, originally lying along the real axis, which has been rotated through an angle θ . The quantity represented by $|r|$ is called its magnitude, whilst θ is sometimes conveniently referred to as its phase. Two notations can be used to denote this process:

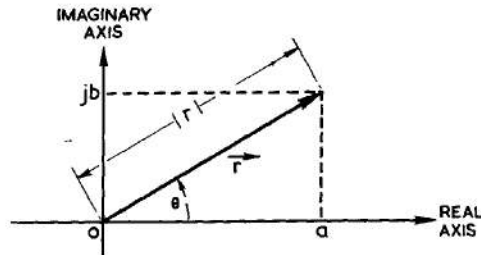

Fig. 7 - Representation of a vector.

- (i) $r = |r| \angle \theta$ (polar form)
 or (ii) $r = |r| \angle j\theta$ (exponential form)

The latter form is used in this volume.

We can thus write

$$\begin{aligned} r = a + jb &= |r| \angle j\theta \\ &= |r| \cos \theta + j |r| \sin \theta; \end{aligned}$$

whence, $a = |r| \cos \theta$

and $b = |r| \sin \theta$

On the other hand, $r = \sqrt{a^2 + b^2}$

and $\tan \theta = \frac{b}{a}$.

We may use complex numbers to represent the effects produced by sinusoidal voltages and currents if the numbers are carefully interpreted as explained in Sec. 8. For these applications, r becomes v or i , whilst $|r|$ becomes $|v|$ or $|i|$. Since $|v|$ or $|i|$ is equal to the maximum or peak value of the real part of the voltage or current, it is more convenient to use the symbols \hat{v} and \hat{i} in place of $|v|$ and $|i|$.

Chap. 1, Sect. 9

For both current and voltage, θ varies uniformly, executing one rotation per cycle, and has angular velocity $\omega = 2\pi f$. Thus,

$$v = \hat{v} \mathcal{E}^{j(\omega t + \phi_1)} \quad \text{and} \quad i = \hat{i} \mathcal{E}^{j(\omega t + \phi_2)}$$

represent a voltage and a current of amplitudes \hat{v} and \hat{i} and phases $\omega t + \phi_1$ and $\omega t + \phi_2$ respectively, the voltage leading the current in phase by the angle

$$\begin{aligned} & \omega t + \phi_1 - (\omega t + \phi_2) \\ = & \phi_1 - \phi_2. \end{aligned}$$

We may also use complex numbers to denote the ratio between the vectors representing voltage and current. Thus

$$\begin{aligned} \frac{v}{i} &= \frac{\hat{v} \mathcal{E}^{j(\omega t + \phi_1)}}{\hat{i} \mathcal{E}^{j(\omega t + \phi_2)}} \\ &= \frac{\hat{v}}{\hat{i}} \mathcal{E}^{j(\phi_1 - \phi_2)}. \end{aligned}$$

This new vector $\frac{v}{i}$ is stationary and is usually denoted by $z = Z \mathcal{E}^{j\phi}$

$$\text{where } \frac{\hat{v}}{\hat{i}} = Z$$

$$\text{and } \phi = \phi_1 - \phi_2.$$

z can also be written in the cartesian form

$$z = R + jX,$$

where R and X correspond to the Resistance and Reactance encountered in the usual analysis.

Care must be taken in using complex numbers to represent voltages and currents in calculations involving power. For example, if the instantaneous value of the voltage applied to a load is indicated by the real part of

$$v = \hat{v} \mathcal{E}^{j(\omega t + \phi_1)}$$

and that of the load current by the real part of

$$i = \hat{i} \mathcal{E}^{j(\omega t + \phi_2)}$$

then the instantaneous power consumed by the load is given not by the real part of the product vi but by the product of the real parts of v and i considered individually. Its mean value is $\frac{1}{2} \hat{v} \hat{i} \cos(\phi_1 - \phi_2)$. $\cos(\phi_1 - \phi_2)$ is called the Power Factor of the load. (In general the Power Factor is defined as the ratio of the mean power consumed by the load to the product of the RMS (Root Mean Square) amplitudes of the load voltage and current. For sinusoidal variations the RMS value (V or I) is $\frac{1}{\sqrt{2}}$ times the maximum value, so that

$$VI = \frac{\hat{v}}{\sqrt{2}} \cdot \frac{\hat{i}}{\sqrt{2}} = \frac{1}{2} \hat{v} \hat{i} \quad)$$

10. Vector Diagrams

Fig. 8 represents a voltage given by

$$v = \hat{v} \mathcal{E}^{j\omega t}$$

as a vector of length \hat{v} and rotating at an angular velocity ω . When several vectors are to be compared, representing sinusoidal voltages or currents of the same frequency, it is usual to replace the diagram of rotating vectors by referring all the vectors to one of the set as a reference vector. This is normally drawn along the horizontal axis, and each of the other vectors is given the appropriate length and phase compared with those of the reference vector; (Fig. 9). All vector diagrams in this volume representing voltages or currents are of this relative type unless otherwise stated.

For convenience, when comparing vectors a vector may be transplanted to any origin in its plane, since the only significant quantities are length and direction, and provided these remain the same the significance is unaltered.

Vectors are added as indicated in Fig. 10(a);

$$\vec{OP} + \vec{PQ} = \vec{OQ}.$$

To subtract one vector from another the vector to be subtracted is reversed in direction and the reversed vector is then added to the other.

E.g., referring to Fig. 10(b),

$$\begin{aligned} \vec{OP} - \vec{OQ} &= \vec{OP} + \vec{PR} \\ &= \vec{OR}. \end{aligned}$$

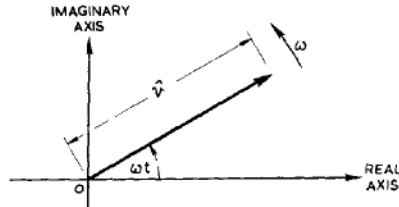

Fig. 8 - Rotating vector.

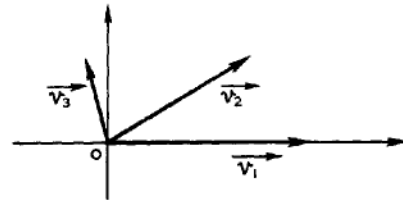

Fig. 9 - Relative vector diagram.

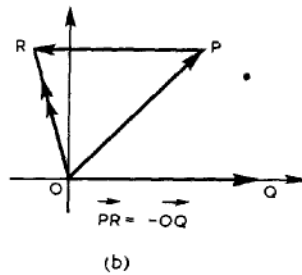
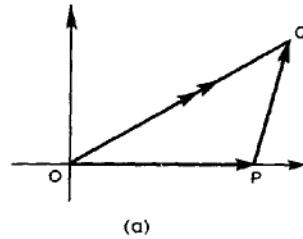

Fig. 10 - Addition and subtraction of vectors.

IMPEDANCES AND ADMITTANCES11. General

As explained in Sec. 8, if v and i are complex quantities representing respectively the sinusoidal voltage applied to a linear two-terminal network and the current which flows through it, the ratio $\frac{v}{i}$ is a complex number called the complex impedance, or, more simply, the impedance of the network. It is denoted by the symbol z . The phase angle of this impedance, which is the angle by which the voltage vector leads the current vector, is denoted by ϕ , and the magnitude of z by Z .

Thus

$$z = Z \angle \phi.$$

(In this volume the phrase "magnitude of the impedance" is used to denote Z ; the common but somewhat confusing practice of using the word Impedance to denote both the complex number z and its magnitude Z is thereby avoided). For a passive network ϕ may have any value between $\pm 90^\circ$ ($\pm \frac{\pi}{2}$ radians). If $0 < \phi \leq 90^\circ$ the network is inductive; for $-90^\circ \leq \phi < 0$ the network is capacitive.

If $\phi = \pm 90^\circ$ the impedance is purely reactive and may be denoted by $z = jX$, where X is the reactance. Such an impedance is presented by an ideal coil of inductance L , where $X = \omega L$, ($\phi = +90^\circ$), or by an ideal condenser of capacitance C , where $X = -\frac{1}{\omega C}$, ($\phi = -90^\circ$).

In practice coils and condensers possess resistance, and the impedance is correspondingly modified; (see Sec. 3).

In general the series resistance R is the real part and the series reactance X the imaginary part of z , so that $z = R + jX$.

The steady state of a two-terminal network in response to a sinusoidal voltage of given frequency is determined exactly when the magnitude Z and phase angle ϕ of the impedance are known.

Alternatively, it may be simpler, particularly when dealing with parallel combinations of networks, to conduct the analysis in terms of admittances rather than impedances. The ratio i/v is a complex number, called the (complex) admittance of the network, and is denoted by y . Hence $y = 1/z$ and the magnitude of the admittance is given by $Y = 1/Z$, so that $y = Y \angle -\phi$.

The real part of y is called the Conductance and is denoted by G , and the imaginary part is called the Susceptance, denoted by B . Thus

$$y = G + jB.$$

The susceptance of an ideal coil of inductance L is $-1/\omega L$, and that of an ideal condenser of capacitance C is ωC . For an ideal resistor of resistance R , $G = 1/R$.

Further comparisons between admittances and impedances are made in Sec. 15.

It should be borne in mind that knowledge of the magnitude and phase angle of an impedance (or an admittance) gives no knowledge of the nature of the components forming a two-terminal network. It merely indicates the overall effect at the frequency considered.

12. Helmholtz's, Thevenin's or Norton's Theorem

This theorem, variously attributed, wholly or in parts, to the above-named scientists, may be stated as follows :-

If a linear network can be divided into two parts, coupled only by a pair of conductors (Fig. 11(a)), then either part (removed network) may be replaced, without affecting the behaviour of the other part (remaining network), by the substitution of

- (i) A constant voltage generator, giving the open-circuit voltage V_{OC} at the terminals of the removed part, in series with its output impedance Z_S ; (Fig. 11(b)); or
- (ii) A constant current generator, giving the short-circuit current I_{SC} at the terminals of the removed part, shunted by its output impedance Z_S ; (Fig. 11(c)).

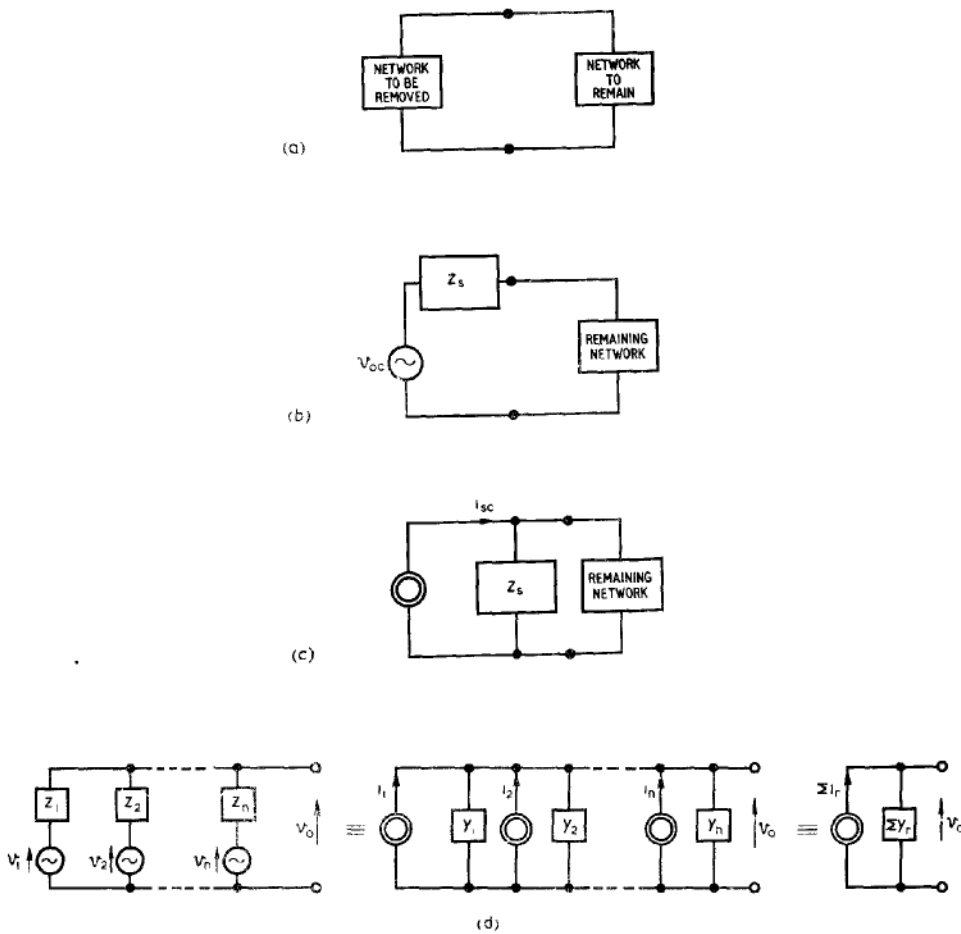

Fig. 11 - Helmholtz's, Thevenin's, or Norton's Theorem; Schematic representation.

The output impedance z_s is defined as the impedance looking into the terminals of the removed network when all its generators are suppressed; (see Sec. 6 for this use of the term "suppress").

This theorem can be extended to networks in which the two parts referred to are coupled by any number of conductors.

It is legitimate to alter the make-up of the remaining network after substitution has been made for the removed network, as the latter is replaced by an equivalent combination of elements which are independent of the former. (Note that such variations cannot be made when the Substitution Theorem (Sec. 2) is employed, without re-specifying the substitute generators).

As an example of the above theorem consider the circuit shown in the left-hand diagram of Fig. 11 (d). Each shunt branch may be considered as a constant-voltage generator (v_r) in series with its output impedance z_r . To calculate the output voltage v_o replace each branch by the equivalent representation i.e. a constant-current generator, giving the short-circuit current i_r , shunted by the output admittance y_r . The resultant current is $\sum i_r$ and the resultant admittance $\sum y_r$.

$$\text{Hence } v_o = \frac{\sum i_r}{\sum y_r}.$$

But $i_r = v_r/z_r$

and $y_r = 1/z_r$.

Hence
$$v_o = \frac{\sum \frac{v_r}{z_r}}{\sum \frac{1}{z_r}}$$

The above result holds equally for DC, and may then be quoted in the form

$$V_o = \frac{\sum V_r/R_r}{\sum 1/R_r}$$

13. Star-Delta Transformation

This useful transformation is illustrated in Fig. 12. Any three-terminal linear network excited at a single frequency may be replaced in the steady state by either of the forms shown at (a) and (b); the arrangement (a) is called a Star (Y) network, and that at (b) a Delta () network. If at such a frequency the impedances forming the Star-network are z_1, z_2 and z_3 , and those forming the Delta-network are z_a, z_b , and z_c , as shown, the conditions for the networks to be equivalent may be written in either of the following forms:-

$$z_a = \frac{z_1 z_2 + z_2 z_3 + z_3 z_1}{z_1}$$

$$z_b = \frac{z_1 z_2 + z_2 z_3 + z_3 z_1}{z_2}$$

$$z_c = \frac{z_1 z_2 + z_2 z_3 + z_3 z_1}{z_3}$$

or inversely:-

$$z_1 = \frac{z_b z_c}{z_a + z_b + z_c}$$

$$z_2 = \frac{z_a z_c}{z_a + z_b + z_c}$$

$$z_3 = \frac{z_a z_b}{z_a + z_b + z_c}$$

In filter theory similar networks are often denoted by the terms T (for Star) and π (for Delta).

14. Series Networks

It may be convenient to represent a two-terminal network by a simple series arrangement having the same impedance as the actual circuit. If this simple circuit consists of a resistance R_s and a reactance X_s in series, as shown in Fig. 13, we have

$$z = R_s + jX_s$$

$$z^2 = R_s^2 + X_s^2$$

$$\text{and } \tan \phi = \frac{X_s}{R_s}.$$

$$\text{Since } \cos \phi = \frac{R_s}{Z},$$

$$Z = R_s \sec \phi.$$

The power factor of the network is $\cos \phi$.

For an inductive network, represented as a resistor of resistance R_s in series with an ideal coil of inductance L_s ,

$$X_s = \omega L_s, \text{ so that}$$

$$\tan \phi = \frac{\omega L_s}{R_s}.$$

For a capacitive network represented as a resistor of resistance R_s in series with an ideal condenser of capacitance C_s ,

$$X_s = -\frac{1}{\omega C_s}, \text{ so that}$$

$$\tan \phi = -\frac{1}{\omega C_s R_s}.$$

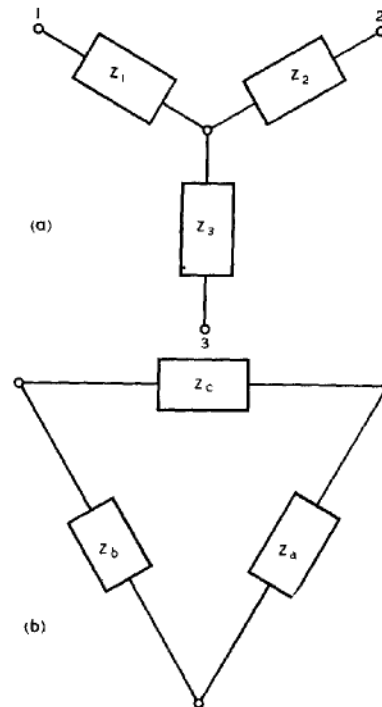

Fig. 12 - Star-delta transformation.

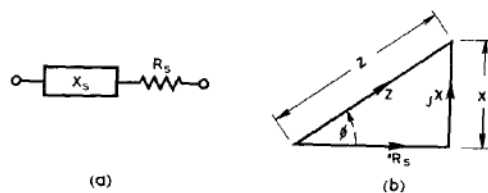

Fig. 13 - Simple series network.

15. Parallel Networks

It may be convenient to represent a network by a simple parallel arrangement having the same impedance as the actual circuit. If this simple circuit consists of a conductance G_p and a susceptance B_p in parallel, as shown in Fig. 14, we have

$$y = G_p + jB_p$$

$$Y^2 = G_p^2 + B_p^2$$

$$\text{and } \tan \phi = -\frac{B_p}{G_p} .$$

$$\text{Since } \cos \phi = \frac{G_p}{Y} ,$$

$$Y = G_p \sec \phi .$$

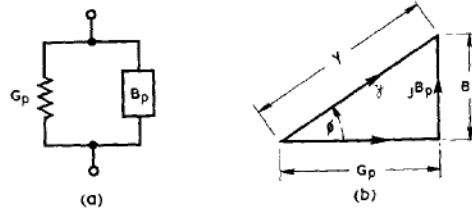

Fig. 14 - Simple parallel network.

The power factor is, as before, $\cos \phi$.

For an inductive network, represented as a resistor of reactance R_p in parallel with an ideal coil of inductance L_p ,

$$G_p = \frac{1}{R_p} \text{ and } B_p = -\frac{1}{\omega L_p} , \text{ so that}$$

$$\tan \phi = \frac{R_p}{\omega L_p} .$$

For a capacitive network represented as a resistor of resistance R_p in parallel with an ideal condenser of capacitance C_p ,

$$B_p = \omega C_p , \text{ so that}$$

$$\tan \phi = -\omega C_p R_p .$$

16. Q - Factor of a Component

This factor is commonly used to indicate the goodness of a reactive component.

For a single component the ratio $\frac{\text{Reactance}}{\text{Resistance}}$ at any frequency is called the Q - factor of the component at that frequency. A practical coil can be represented approximately by an ideal inductance L in series with the resistance R of the coil; (see Fig. 4(a)). In this case the Q of the coil is $\frac{X_L}{R} = \frac{L}{R}$. It follows from Secs. 14 and 15 that $Q = \tan \phi$;

also that if the component were to be represented for convenience as a pure susceptance in parallel with a pure conductance, Q would be given by $\frac{\text{Susceptance}}{\text{Conductance}}$. Since for a condenser this latter representation is more common, as indicated in Fig. 4(b), the Q - factor of

such a condenser is given by

$$Q = \frac{\omega C}{\frac{1}{R}} = \omega CR .$$

Although the above formulae suggest that the Q of either component is proportional to frequency, in practice this is not the case for the following reasons :-

- (i) The representation adopted is approximate only and is not accurate at very high frequencies. For example, the shunt reactance of the self-capacitance of the coil reduces the effective inductance and eventually the coil resonates with its self-capacitance as a parallel resonant circuit.
- (ii) The resistance of a coil is not constant, but, owing to skin effect (which causes the current to be forced more and more towards the surface of the conductor) increases as the frequency rises.

For these and other reasons there is a maximum value for the Q - factor of any coil (or condenser) occurring at a definite frequency; (Fig. 15). Practical values for the Q - factor of a coil for use at radio frequencies of several megacycles per second are from 50 - 200. The higher the value of Q the narrower is the frequency band over which it is maintained.

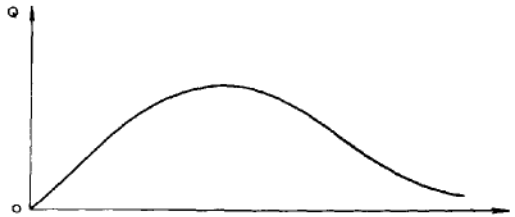

Fig. 15 - Variation of the Q -factor of a coil with frequency.

The Q - factor for an air-spaced condenser is very large compared with that of a coil. For a dielectric other than air or a vacuum the losses in the condenser are due almost entirely to the dielectric.

However, Q is still usually much greater for such a condenser than for the coils used at the same frequency, and since

$$Q = |\tan \phi| \quad \text{and is large, } \phi \doteq 90^\circ \text{ and } |\tan \phi| \doteq \frac{1}{\cos \phi} .$$

Hence the Q - factor of a condenser with a solid dielectric is approximately equal to $\frac{1}{F}$, where F is the power factor of the dielectric.

This may have a value from 100 to 5000.

17. Equivalent Series and Parallel Networks

A two-terminal network may be represented at a single frequency by :-

- (i) an equivalent series combination, or
- (ii) an equivalent parallel combination,

of simple components, as described in Secs. 13 and 14. In either case the impedance of the equivalent network must be the same as that of the actual network, having the same magnitude and phase angle.

Suppose z is the network impedance, of magnitude Z and phase angle ϕ , and y the admittance, of magnitude Y . Let the equivalent series combination consist of R_s and X_s in series, and the equivalent parallel combination of G_p and B_p in parallel. The following relations then hold :-

$$z = \frac{1}{y};$$

$$Z = \frac{1}{Y};$$

$$R_s = Z \cos \phi,$$

$$G_p = Y \cos \phi,$$

$$\text{Hence } R_s G_p = \cos^2 \phi$$

$$\text{or } R_s = R_p \cos^2 \phi, \quad (\text{where } R_p = \frac{1}{G_p}).$$

$$\text{Also, since } X_s = R_s \tan \phi$$

$$\text{and } B_p = -G_p \tan \phi,$$

$$\begin{aligned} X_s B_p &= -\tan^2 \phi \cos^2 \phi \\ &= -\sin^2 \phi \end{aligned}$$

$$\text{Hence } X_s = X_p \sin^2 \phi, \quad (\text{where } X_p = \frac{-1}{B_p})$$

$$\text{The relations } R_s = R_p \cos^2 \phi,$$

$$\text{and } X_s = X_p \sin^2 \phi$$

make possible a rapid conversion from a series to a parallel arrangement or vice versa.

When the network consists of a single coil or condenser of large Q we may write $\tan \phi = Q$ where $Q \gg 1$.

$$\text{Then } \sin^2 \phi = \frac{Q^2}{1 + Q^2} \doteq 1$$

$$\text{and } \cos^2 \phi = \frac{1}{1 + Q^2} \doteq \frac{1}{Q^2}.$$

The equations relating series and parallel components may then be written

$$R_p \doteq Q^2 R_s$$

$$\text{and } X_p \doteq X_s.$$

18. FREQUENCY CHARACTERISTICS OF TWO-TERMINAL NETWORKS

Certain properties of simple linear networks with small losses can easily be deduced if the presence of resistive components is neglected, and a first approximation to the behaviour of the network can thereby be obtained. The impedance of any of the remaining elements, or combination of these elements, is then always reactive (or, in particular cases, zero or infinite).

For example, the reactance X_L of an ideal coil is ωL ,

and this is directly proportional to frequency; (Fig. 16(a)). The reactance X_C of an ideal condenser is $\frac{1}{\omega C}$ and is inversely proportional to frequency, so that a graph showing the variation of X_C with f is a rectangular hyperbola; (Fig. 16(b)). The variation of the resultant reactance of these two in series is found by adding the ordinates of the curves (a) and (b), and is shown at (c).

For a certain value of f given by f_r , where

$$\omega_r L = \frac{1}{\omega_r C},$$

i.e.

$$\omega_r = \frac{1}{\sqrt{LC}},$$

so that

$$f_r = \frac{1}{2\pi\sqrt{LC}},$$

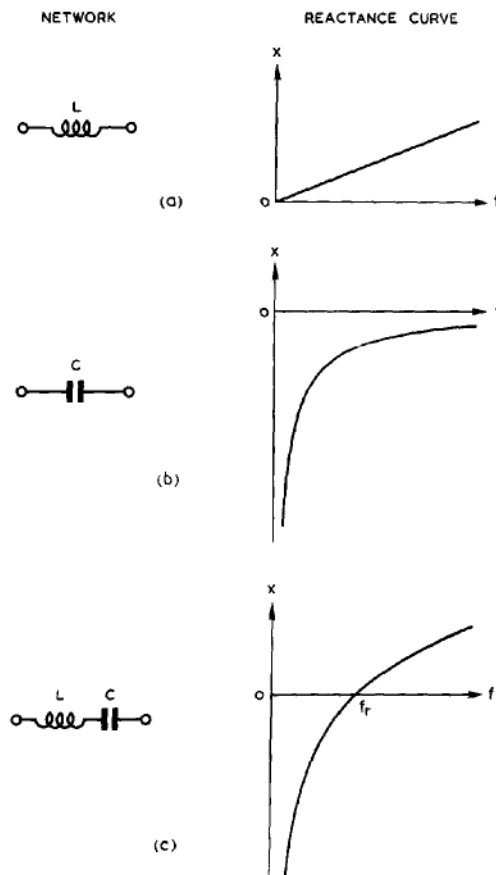

Fig. 16 - Reactance curves of simple non-resistive networks.

the resultant reactance of L and C in series is zero. This frequency is called the Resonant Frequency of the circuit. For lower frequencies this circuit, formed of ideal reactive components, is purely capacitive, and for higher frequencies, purely inductive.

For parallel circuits it is more convenient to use susceptances instead of reactances. The susceptance B_L of an ideal coil and B_C of an ideal condenser vary with frequency as illustrated in Fig. 17(a) and (b) respectively, and the resultant susceptance of the two in parallel is formed by adding the ordinates of the curves (a) and (b). This resultant is shown at (c). As for the reactance curve of the series circuit, this curve has a position of zero susceptance at the frequency

$$f_r = \frac{1}{2\pi\sqrt{LC}}$$

called the resonant frequency of the parallel circuit. For lower frequencies this circuit is purely inductive, and for higher frequencies, purely capacitive.

Chap. 1, Sect. 18

If the susceptance of any combination of L and C is known the reactance may be obtained by taking the reciprocal of the susceptance and changing its sign, since for a purely reactive impedance $X = \frac{-1}{B}$. The

converse process also holds. Equivalent reactance and susceptance curves obtained in this way for the series and parallel combinations already described are shown in Figs. 18(a) and (b), together with similar curves for more complicated networks, at (c) and (d).

An important property of these reactance and susceptance curves is that the slope is always positive. The reason for this is clear for the simple expressions $X = \omega L$ or $\frac{-1}{\omega C}$, $B = \omega C$ or $\frac{-1}{\omega L}$, since

in each case differentiation with respect to ω or f yields a positive derivative. The general case may easily be shown by induction. If X_1 is the reactance of any combination of L and C, and either L_1 or C_1 is added in series with X_1 then if $\frac{dX_1}{d\omega}$ is positive so also is $\frac{d}{d\omega} (X_1 + \omega L_1)$ or $\frac{d}{d\omega} (X_1 - \frac{1}{\omega C_1})$. In fact, each additional series reactance increases the slope at that frequency. A similar proposition is true if a susceptance is added in parallel with B_1 . Hence, since $\frac{dX}{d\omega}$ and $\frac{dB}{d\omega}$ are always positive for the simplest networks, namely those consisting of a single reactance, they are always positive for any series or parallel combination of such networks.

This fact makes the sketching of reactance and susceptance curves relatively simple. One is seldom interested in the exact variation of reactance or susceptance with frequency. It is usually sufficient in the first instance to plot approximately the frequencies at which the ordinate of the graph considered is zero or infinite, i.e.,

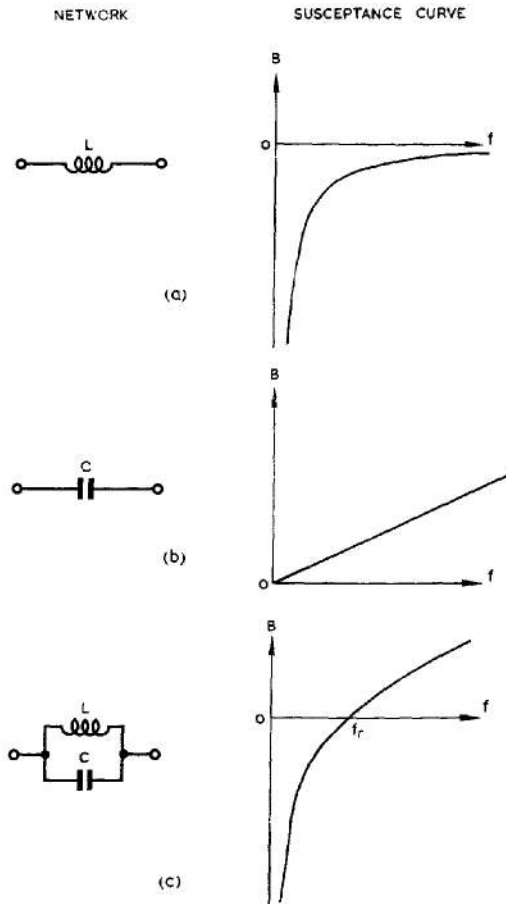

Fig. 17 - Susceptance curves of simple non-resistive networks.

the frequencies of series and parallel resonance. The general shape of the graph can immediately be sketched approximately once these points are determined.

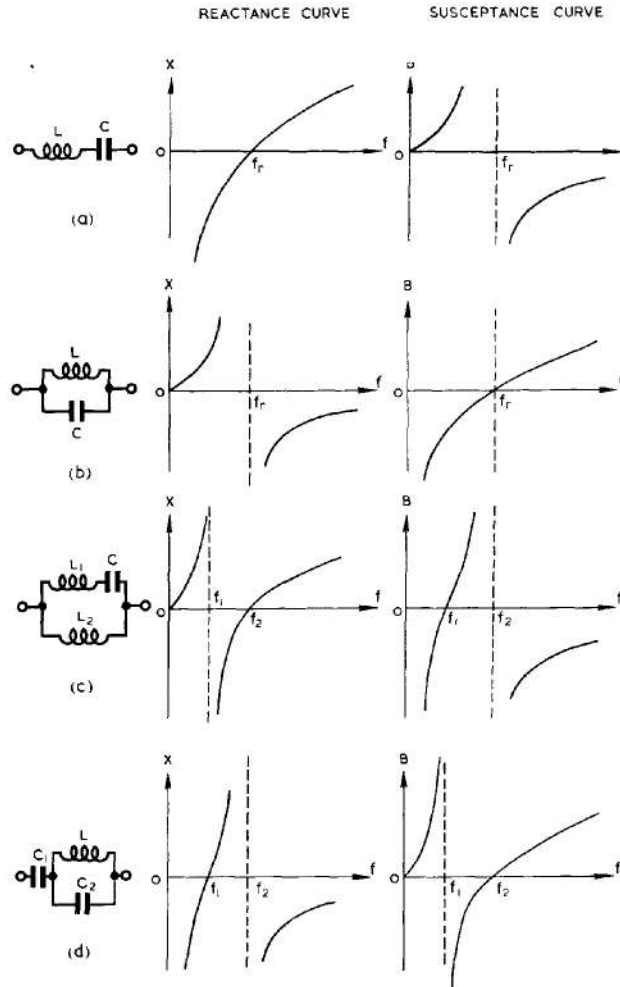

Fig. 18 - Reactance and susceptance curves of various non-resistive networks.

It has been possible to plot the variation of impedance or admittance, showing the variation both of magnitude and phase angle ($\pm 90^\circ$) on a single graph in Figs. 16 - 18 because the components were chosen as ideally reactive, having no resistance. In practice all components have resistance, and for accurate representation more than one two-dimensional cartesian diagram is necessary to represent the variation of magnitude and phase angle with frequency.

Fig. 19(a) shows the result of converting the reactance diagram of Fig. 16(c) for the Series Resonant Circuit, consisting of L and C in series, to a diagram representing the magnitude of the impedance. Since $R = 0$ and $Z = |X|$, the Z-curve is obtained by changing the sign of X in Fig. 16(c) where this is negative.

The phase variation is also shown.

We now consider the effect of inserting in series with L and C a resistance R, sufficiently small so that at the resonant frequency the reactance X_L (which is then equal to $-X_C$) is much greater than the resistance R.

The effect of R is appreciable only near resonance, since then the positive and negative reactances cancel each other, so that at the resonant frequency the impedance is R. For only small deviations from resonance the resultant reactance is much greater than R and the effect of R is small. This is illustrated in Fig. 19(b).

A more precise account of the behaviour of the circuit in the neighbourhood of the resonant frequency is given by the Universal Resonance Curve; (Sec. 19).

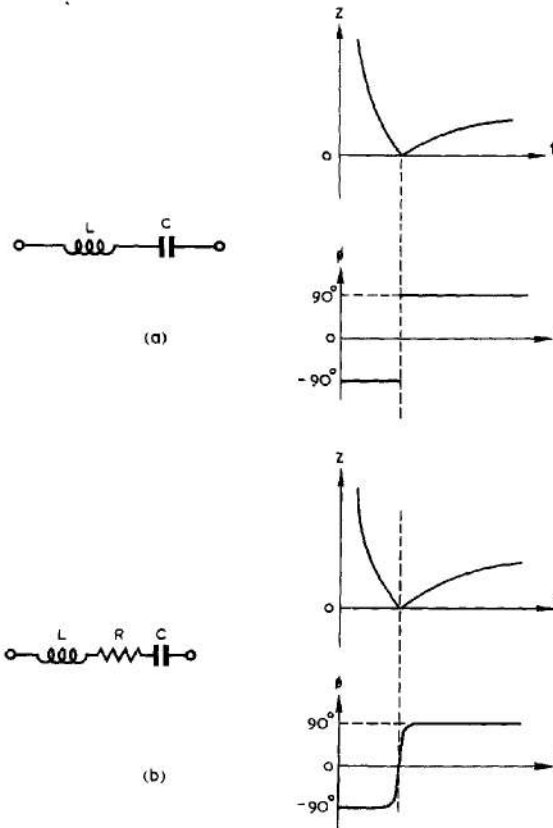

Fig. 19 - Effect of small series resistance on series L-C circuit.

A corresponding modification is needed to the diagram representing the magnitude of the admittance. Where the magnitude of the impedance is small, but not zero, as in Fig. 19(b), that of the admittance is large, but not infinite. Conversely, zeros in the admittance curve for resistance-less networks are replaced by finite admittances of small magnitude, corresponding to impedances of large, but not infinite magnitudes.

A similar procedure usually enables the behaviour of more complicated networks to be assessed qualitatively with little detailed analysis. The modifications necessary to the impedance curves of purely reactive networks to allow for slight losses usually consist of replacing zeros by small, and infinities by large, impedances and adapting the neighbouring portions of the diagrams accordingly. The resonant frequencies are little changed provided the losses are sufficiently small. (The procedure may be invalid if zeros and infinities in the reactance or susceptance graphs are very close together)

19. RESONANCE

It follows from Sec. 17, (Fig. 13(c)) that at a certain frequency the total reactance of L and C in series is zero. Above this frequency the circuit is inductive ($\phi = +90^\circ$) and below, capacitive ($\phi = -90^\circ$). Similarly, Fig. 14(c) shows that at some frequency the total susceptance of L and C in parallel is zero. Above this frequency the circuit is capacitive ($\phi = -90^\circ$) and below, inductive ($\phi = +90^\circ$). In both cases the resonant frequency is given by the relation

$$\omega_r L = \frac{1}{\omega_r C}, \text{ so that } f_r = \frac{1}{2\pi\sqrt{LC}}$$

These results are modified by the presence of resistance, some resistance being unavoidable, notably the series resistance of the coil.

For the series (acceptor) circuit, if R is the total series resistance of the circuit, the impedance can be written

$$z = R + j\left(\omega L - \frac{1}{\omega C}\right)$$

and at resonance the reactive component is zero so that $z = R$. The reactive component grows rapidly and becomes large in comparison with R for very small deviations from resonance provided the ratio

$$\frac{\text{the magnitude of the reactance of either kind at resonance}}{\text{the total series resistance of the circuit}}$$

is large. This ratio is called the Q - factor of the circuit. It follows that

$$Q = \frac{\omega_r L}{R} = \frac{1}{\omega_r C R} = \frac{1}{R} \sqrt{\frac{L}{C}}$$

Since any equivalent series resistance associated with the condenser is usually negligible by comparison with the series resistance of the coil, in most series circuits used for HF work R is the resistance of the coil, so that the Q - factor of the circuit is the same as the Q - factor of the coil at the resonant frequency of the circuit.

We may write

$$\omega L = R \cdot \frac{\omega}{\omega_r} \cdot \frac{\omega_r L}{R} = RQ \frac{\omega}{\omega_r}$$

$$\text{and } \frac{1}{\omega C} = R \cdot \frac{\omega_r}{\omega} \cdot \frac{1}{\omega_r C R} = RQ \frac{\omega_r}{\omega}$$

$$\text{Hence } z = R + j RQ \left(\frac{\omega}{\omega_r} - \frac{\omega_r}{\omega} \right)$$

$$\text{If we put } f = f_r (1 + \delta)$$

$$\text{then } \frac{\omega}{\omega_r} = \frac{f}{f_r} = 1 + \delta,$$

$$\text{and } \frac{\omega_r}{\omega} = \frac{1}{1 + \delta} \approx 1 - \delta \text{ provided } \delta \text{ is small.}$$

Hence $\frac{\omega}{\omega_r} - \frac{\omega_r}{\omega} \approx 2\delta$

Thus $z = R(1 + j2Q\delta)$.

As is shown in Sec. 14,

$$Z = R \sec \phi ;$$

also $\tan \phi = \frac{X}{R}$,

$$\begin{aligned} \text{but } z &= R + jX \\ &= R + jR \tan \phi \\ &= R(1 + j \tan \phi). \end{aligned}$$

Comparing this with

$$z = R(1 + j2Q\delta) \text{ above, we see that}$$

$$\tan \phi = 2Q\delta .$$

The approximations involved in the above analysis depend on δ being small. This is true for quite large values of Q provided Q is large. The variation of ϕ and $\cos \phi$ with $Q\delta$ is shown in Fig. 20. This graph is known as the Universal Resonance Curve. It may be used to represent the response of any resonant circuit in the neighbourhood of resonance provided Q is known and is large.

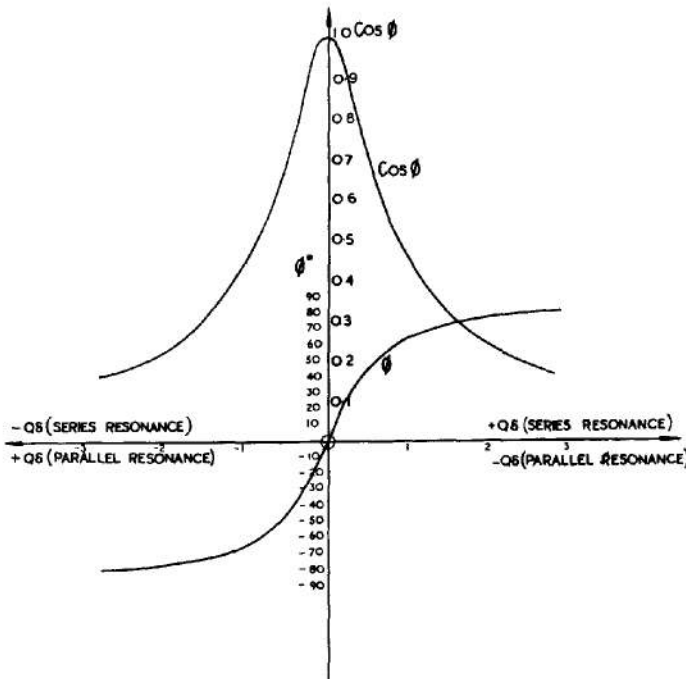

Fig. 20 - Universal resonance curve.

The analysis of the parallel (rejector) circuit of Fig. 15(c) when the resistance of the coil is taken into account is more complicated than that given above for the series resonant circuit. (See :- BR 229 Paras. 316 and 317; AP 1093 Chap. V Paras. 48 - 53)

A simple approximate treatment can be obtained using the results of Sec. 17. For any angular frequency ω we may replace the series combination of L and R by the parallel combination of L_p and R_D as shown in Fig. 21(a), provided

$$R = R_D \cos^2 \phi_L$$

and
$$L = L_p \sin^2 \phi_L, \text{ where } \tan \phi_L = \frac{\omega L}{R} = \frac{R_D}{\omega L_p}$$

The analysis of the network formed by R_D , L_p and C in parallel (Fig. 21(b)) is then very similar to that of the network containing R, L and C in series, and the resonant frequency is given by

$$f_r = \frac{1}{2 \pi \sqrt{L_p C}}$$

At resonance the susceptance of C is exactly cancelled by that of L_p and the resultant impedance is the resistance R_D , called the Dynamic Resistance of the circuit. G_D , the reciprocal of R_D , is the Dynamic Conductance. The Q - factor of the circuit is defined as the ratio

$$\frac{\text{the magnitude of the susceptance of either kind at resonance}}{\text{the dynamic conductance}}$$

and therefore

$$Q = \frac{\omega_r C}{G_D} = \frac{\omega_r L_p}{G_D} = \omega_r C R_D = \frac{R_D}{\omega_r L_p},$$

and this is equal to $\frac{\omega_r L}{R} = \tan \phi_L =$ the Q - factor of the coil at the resonant frequency, ϕ_L being the phase angle of the coil impedance at this frequency.

Provided Q is large so that $Q^2 \gg 1$, we may put $L_p \doteq L$ and $R_D \doteq Q^2 R$. Also, the substitution of the parallel network of Fig. 21(a) for the series arrangement may be assumed to hold for the same values of L_p and R_D in the immediate neighbourhood of resonance.

The following relations then hold :-

$$Q \doteq \frac{1}{\omega_r C R} \doteq \frac{1}{R} \sqrt{\frac{L}{C}} \doteq R_D \sqrt{\frac{C}{L}};$$

$$f_r \doteq \frac{1}{2 \pi \sqrt{LC}}$$

$$\text{In all cases } R_D = \frac{L}{CR}.$$

The exact expression for f_r can be obtained by substituting for I_p the exact relation

$$\begin{aligned} I_p &= L \operatorname{cosec}^2 \phi_L \\ &= L \left(1 + \frac{R^2}{\omega_r^2 L^2} \right). \end{aligned}$$

Since $\omega_r^2 I_p C = 1$, this gives

$$\omega_r^2 L \left(1 + \frac{R^2}{\omega_r^2 L^2} \right) C = 1$$

$$\text{or } \omega_r^2 LC = 1 - \frac{CR^2}{L}$$

$$\text{Hence } \omega_r = \frac{1}{\sqrt{LC}} \sqrt{1 - \frac{CR^2}{L}}$$

$$\doteq \frac{1}{\sqrt{LC}} \sqrt{1 - \frac{1}{Q^2}}.$$

Unless $\frac{CR^2}{L} < 1$ there is no frequency at which the susceptance is zero, and the network is capacitive at all frequencies; (see Sec. 21).

Effect of Parallel Damping on Rejctor Circuit

The value of Q for the undamped circuit (i.e. containing no additional damping other than the series resistance R) may be denoted by ${}_0Q$, and the corresponding dynamic resistance by ${}_0R_D$. If additional resistance R' is placed in parallel with the network, R_D is correspondingly modified, and may be denoted by ${}_1R_D$:-

$$\frac{1}{{}_1R_D} = \frac{1}{{}_0R_D} + \frac{1}{R'}; \quad (\text{Fig. 21 (c)}).$$

The Q - factor of the resultant circuit is modified according to the relation

$$\frac{{}_0Q}{{}_0R_D} \doteq \frac{{}_1Q}{{}_1R_D}, \quad \text{so that for}$$

parallel damping, $Q \propto R_D$, other parameters remaining unchanged.

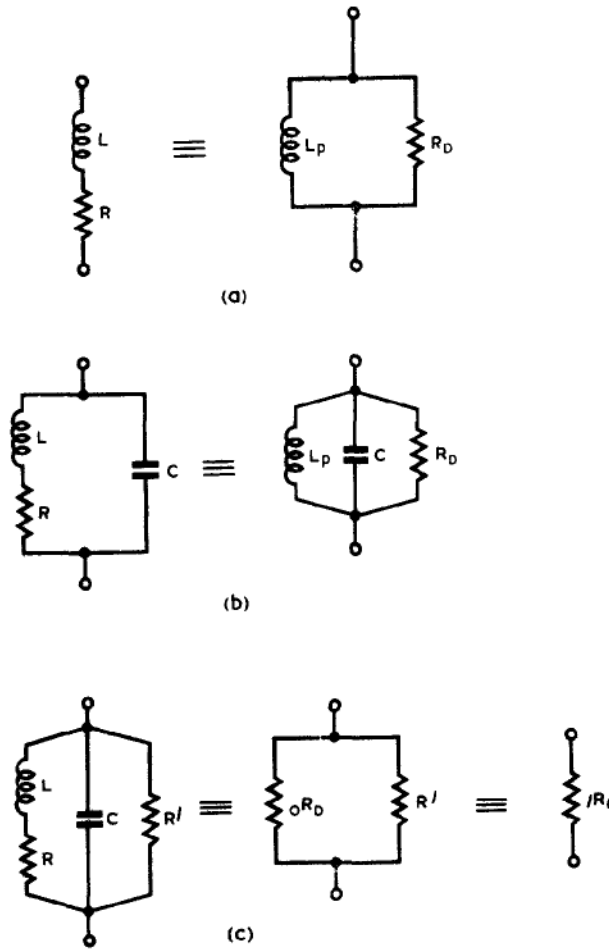

NOTE -
EQUIVALENCES DENOTED \equiv ARE VALID
ONLY IN THE NEIGHBOURHOOD OF ONE
FREQUENCY - f_r

Fig. 21 - Rejactor circuit.

Use of Universal Resonance Curve

Provided Q is large the universal resonance curve gives accurately the variation of impedance (or admittance) of a series or parallel resonant circuit in the neighbourhood of resonance. For example, consider an acceptor circuit fed by an EMF of constant amplitude \hat{v}_i and variable frequency f ; (Fig. 22 (a)). The resonant frequency is f_r , and Q and R are known. The current at resonance, i.e., when the input EMF is of frequency f_r , is of amplitude $\hat{i}_r = \frac{\hat{v}_i}{R}$.

At other frequencies the amplitude of the current is :-

$$\text{thus } \hat{i} = \frac{\hat{v}_i}{Z} = \frac{\hat{v}_i}{R \sec \phi} = \frac{\hat{v}_i}{R} \cos \phi = \hat{i}_r \cos \phi.$$

The universal resonance curve gives the variation of $\cos \phi$, but plotted against $Q \delta$. However, since Q and f_r are known f can be determined from the relation

$$\delta = \frac{f - f_r}{f_r}$$

Chap. 1, Sect. 19

so that $f = f_r (1 + \frac{Q\delta}{Q})$;

and for each value of $Q\delta$ the corresponding frequency f can be found.

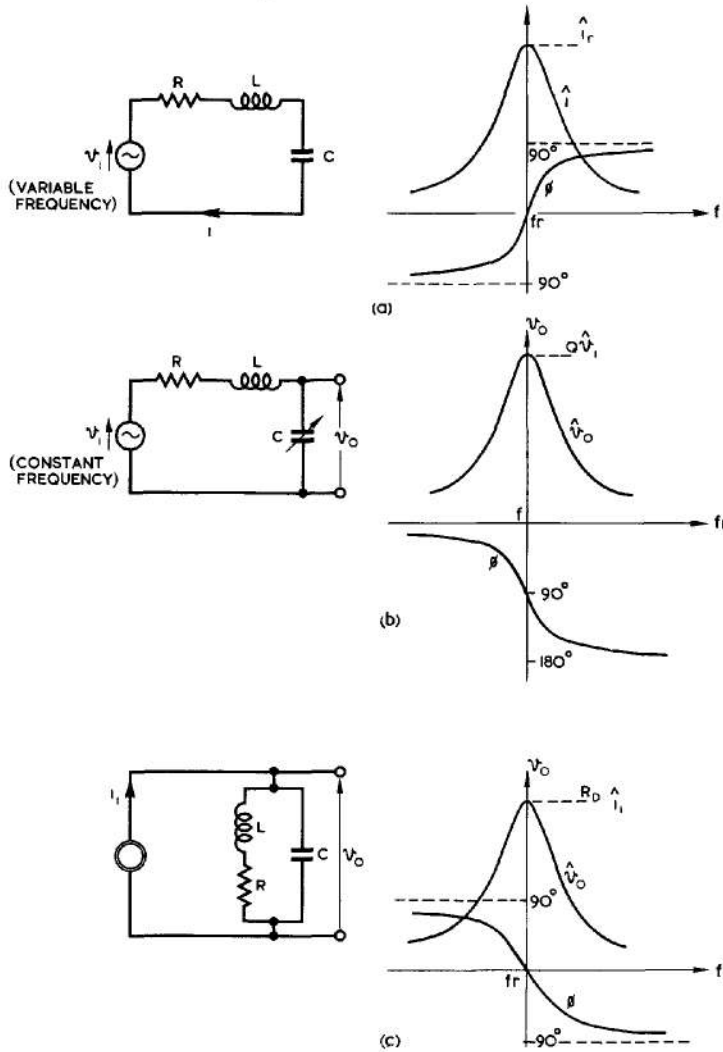

Fig. 22 - Use of universal resonance curve.

The response can then be represented as in Fig. 22(a).

When the current is divided by \hat{v}_1 the curve shows the variation of the magnitude of the admittance.

Alternatively, the EMF may be of constant amplitude \hat{v}_1 and frequency f , while one of the reactive components is varied as illustrated in Fig. 22(b). Provided Q is large and the series resistance of the circuit is constant, the universal resonance curve may be used to represent the variation of the voltage across either reactive component as the resonant frequency is varied. e.g., the

capacitance of the condenser may be varied and the movement calibrated in resonant frequencies. For a given Q , f_r may be determined for each value of $Q\delta$ from the relation

$$f_r = \frac{f}{1 + \frac{Q\delta}{Q}} \approx f(1 - \frac{Q\delta}{Q})$$

The output voltage at resonance is $Q\hat{v}_i$, so that the variation is as shown in Fig. 22(b). The ϕ -variation of v_o is obtained by first plotting the variation of phase of the circuit current; for $f_r > f$, i.e., below resonance, the circuit is capacitive, and above resonance, for $f_r < f$, inductive. The required phase-variation of the output voltage is similar, but delayed by 90° on the phase of the current, and hence appears as shown in the figure. This example indicates why Q is sometimes known as the "magnification factor".

Fig. 22(c) illustrates the use of the universal resonance curve for a rejector circuit fed by an ideal current generator of constant amplitude \hat{i}_i but varying frequency f . The output voltage has amplitude \hat{v}_o where

$$\begin{aligned} \hat{v}_o &= \hat{Z} \hat{i}_i \\ &= \hat{i}_i R_D \cos \phi. \end{aligned}$$

The method of determining the frequency scale is the same as for the series circuit discussed first. When the ordinate is divided by \hat{i}_i the curve becomes one of impedance.

20. COUPLED CIRCUITS

The theory of simple coupled circuits is considered in Service Reference Books as follows:-

BR 229 Paras. 334 - 337.

26/Manuals/1577 Sec. 10 (and Chap. II app.B.)

AP 1093 Chap. VI. Paras. 23 - 31.

A few additional remarks are made here with a view to presenting some of the results in the form in which they are used in the remaining chapters.

Two simple series networks coupled by means of their mutual inductance are illustrated in Fig. 23. The primary circuit is considered to be fed by an ideal voltage generator of EMF v_G . The mutual inductance between the circuits is M ; the total secondary impedance (i.e. the impedance of the secondary circuit when $M = 0$) is:-

$$z_2 = R_2 + j \left(\omega L_2 - \frac{1}{\omega C_2} \right).$$

The total primary impedance, i.e. the impedance of the primary circuit when $M = 0$, is

$$z_1 = R_1 + j \left(\omega L_1 - \frac{1}{\omega C_1} \right),$$

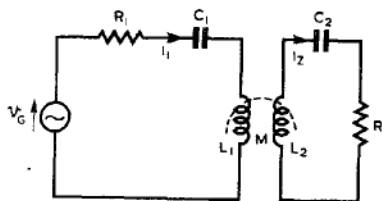

Fig. 23 - Circuits coupled by mutual inductance.

but it will be shown that this is not the impedance presented to the generator.

The EMF induced in the secondary circuit due to i_1 in the primary is

$$\begin{aligned} v_2 &= M \frac{di_1}{dt} \\ &= j\omega M i_1. \end{aligned}$$

This causes a current i_2 to flow in the secondary circuit given by

$$i_2 = \frac{v_2}{z_2} = \frac{j\omega M i_1}{z_2}.$$

Owing to this current an EMF is induced in the primary circuit given by

$$\begin{aligned} v_1 &= M \frac{di_2}{dt} \\ &= j^2 \frac{\omega^2 M^2}{z_2} i_1 \\ &= - \frac{\omega^2 M^2}{z_2} i_1. \end{aligned}$$

The net EMF in the primary circuit is therefore $v_G + v_1$, so that

$$v_G - \frac{\omega^2 M^2}{z_2} i_1 = z_1 i_1$$

and therefore the impedance presented to the generator is

$$z = \frac{v_G}{i_1} = z_1 + \frac{\omega^2 M^2}{z_2}.$$

The second term on the right hand side of this equation is called the Reflected Impedance of the secondary circuit.

21. BROAD-BANDING

The principle of Broad-banding is one of wide application in radar circuits. In its extreme form the requirement is to design a network which will pass uniformly signals of all frequencies within a wide band and which will reject all others; but for most purposes a rough approach to this ideal is satisfactory. Band-pass circuits are dealt with elsewhere, and this section is restricted to the consideration of a network which is essentially a simple type of low-pass filter: i.e. it gives a response which is reasonably uniform for low frequency signals, but which eventually falls off as the frequency is raised.

The impedance of an ideal resistance is constant at all frequencies. In practice this cannot be achieved, particularly because of unavoidable shunt capacitance, which reduces impedance at high frequencies. This is illustrated in Fig. 24(a). For low frequencies,

$$Z \doteq R,$$

Chap. 1, Sect 21

but for higher frequencies, at which $\frac{1}{\omega C}$ is small enough to be comparable with R, the magnitude of the impedance is given by

$$Z = R \cos \phi,$$

and this becomes very small as ϕ approaches -90° , i.e. for $\omega CR \gg 1$.

If a coil is inserted in series with R, as shown at (b), the increase in the impedance of the series arm as the frequency rises partially offsets the fall in the impedance of the condenser, and the frequency response is improved.

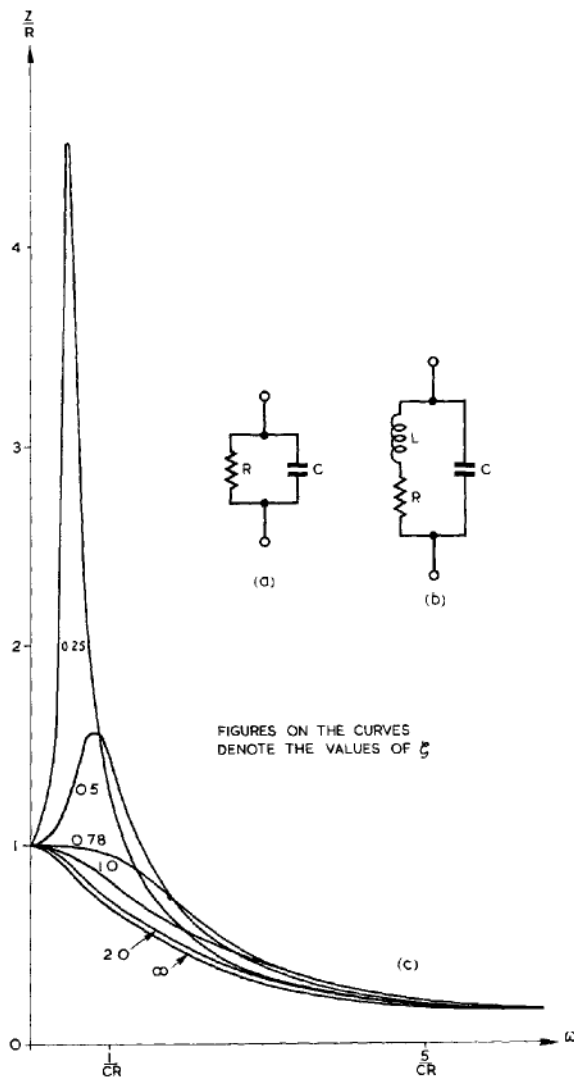

Fig. 24 - Broadbanding; use of series inductance to counteract shunt capacitance.

It is not practicable to use the universal resonance curve for this heavily damped circuit, since the Q - factor is very small. A more useful criterion is the Damping Ratio (See Chap. 2, Sect. 10), which for this circuit is given by

$$\zeta = \frac{R}{2} \sqrt{\frac{C}{L}}$$

$$\left(\text{Compare } \frac{1}{2Q} \doteq \frac{R}{2} \sqrt{\frac{C}{L}} \right)$$

when Q is large).

For $\zeta > \frac{1}{2}$ there is no "resonant frequency" i.e. no frequency at which the phase-angle of the network is zero, but the network is capacitive at all frequencies.

The variation of the magnitude of the impedance with frequency for different values of ζ is shown in Fig. 24(c). The magnitude of the impedance is maintained approximately equal to R for a relatively wide frequency range if ζ is made about 0.78. For smaller values of ζ , i.e., larger L , the network exhibits resonance properties, with peaks to the impedance-frequency diagram which may be undesirable. For larger values of ζ , i.e., smaller L , the bandwidth is reduced. Other slightly different values of ζ may be chosen for various reasons, e.g., maximum constancy of phase- or time-delay instead of maximum constancy of the magnitude of the impedance.

This file was downloaded
from the RTFM Library.
Link: www.scottbouch.com/rtfm

Please see site for usage terms,
and more aircraft documents.

