

Chapter 10
RELAXATION OSCILLATORS AND RELAYS
List of Contents

	Sect.
Introduction	1
Two-valve circuits	
The multivibrator	2
Cathode-coupled multivibrators	3
Relay circuits	4
One-valve circuits	
Transitron circuits	5
Transitron relaxation oscillator	6
Transitron relay	7
The blocking oscillator	8
Circuits employing the Miller time-base principle	
General	9
The sanatron	10
The phanastron	11

CHAPTER 10

RELAXATION OSCILLATORS AND RELAYS

1. INTRODUCTION

The circuits which are considered in this chapter involve the determination of time-intervals. In some cases (Relaxation Oscillators) their function is much the same as that of a simple oscillator, i.e. to produce recurrent changes of voltage at regular intervals of time. In others (Relays) it is required to produce, in response to some input pulse, an output variation which occurs at some predetermined instant after the occurrence of the input. In such cases the circuit acts in the nature of a delay device, and does not produce any output until an input or triggering pulse is applied.

Relaxation oscillators are normally used to generate low frequency oscillations, e.g. from a few cycles per second to a few kilocycles per second. They are widely used to control the timing of the operation of various circuits in radar equipments such as time-base generators, modulators, aerial switching valves, etc. A relaxation oscillator may readily be synchronised with a succession of pulses or any recurrent voltage variation whose frequency is slightly greater than the natural frequency of the oscillator.

Relays are used to produce delayed pulses, and find common application in time-base circuits, e.g. for the production of range markers, trace-brightening pulses, etc., at predetermined positions on the time base.

Any of these circuits may also be arranged so that when triggering or synchronising pulses are applied at regular intervals, they are in effect divided into groups of two, three or more pulses. Only the first pulse of each group affects the circuit, so that the frequency of the output voltage variations is a submultiple of the frequency of the input pulses. This process is called Counting-Down.

Each of these circuits depends for its action on the existence of at least two distinct conditions of operation, either of which may be stable or unstable. For example, in a two valve circuit either valve may be conducting while the other is non-conducting. The transition from one condition to the other takes the form of a rapid cumulative action due to regeneration inherent in the circuit. The circuit is in a stable state if an external impulse is needed to cause this transition; otherwise it remains in its existing state. The circuit is in an unstable state if, after an interval (time of relaxation) it reverts of its own accord to the alternative condition.

Such circuits may be classified under three headings, as follows:-

(1) Circuits with no stable state of operation

Circuits of this type are known as Relaxation Oscillators. A circuit of a Relaxation Oscillator is shown in Fig. 492. The condenser C charges through the resistor R until the voltage across it is sufficient to cause the neon valve to strike. (The interval during which the condenser charges is the time of relaxation). Upon striking, the valve presents a low resistance and the condenser discharges rapidly until the neon current falls below its extinction value. The valve subsequently presents an open circuit and the condenser

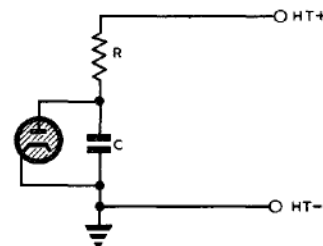

Fig.492 - Simple relaxation oscillator (flashing neon).

recharges and the cycle of operation repeats. Other well-known examples are the Multivibrator and Blocking Oscillator; these are considered below.

(ii) Circuits with one stable state of operation

A circuit of this type is known as a Relay.

Such a circuit rests naturally in its stable condition, but on the application of a triggering impulse an abrupt transition to the unstable state occurs. After an interval of relaxation the circuit reverts to its stable condition.

A circuit of a relay is shown in Fig. 493. In the stable state the gas-filled triode is non-conducting, the grid voltage being maintained below cut-off and the anode voltage remaining at H.T. If the grid voltage is raised momentarily above cut-off, by an external impulse of very short duration, the valve conducts heavily and the condenser is discharged. This unstable state continues after the triggering pulse is removed, and is terminated only when the valve current falls below its extinction value. Subsequently C charges through R and the circuit reverts to its stable condition.

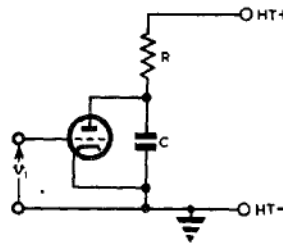

Fig. 493 - Simple relay (triggered thyatron time-base).

(iii) Circuits with two stable states of operation

A circuit of this type is known as a Counter. Such a circuit rests naturally in either of its two stable conditions, but on the application of a triggering impulse an abrupt transition from one stable state to the other takes place. The circuit rests in this second condition until a further triggering impulse causes it to return to the first. This type of circuit, a typical example of which is the Eccles-Jordan Circuit, has little if any application in radar equipment and is not discussed further.

Relaxation oscillators and relays may take the form of two-valve or single-valve circuits. In most cases the time intervals are determined by the exponential charging or discharging of a condenser through a resistor. In some circuits the linear charging principle of the Miller time base is used (see Chap. 11, Sec. 10). Circuits which utilise this principle are discussed separately in Secs. 9 to 11.

In the description of the Multivibrator circuit, which is considered first, the action is discussed more or less in detail, each main or subsidiary feature of the oscillations being dealt with as it occurs during the sequence of operation. This procedure is adopted for the sake of readers encountering this type of action for the first time. In the subsequent description of circuits where the action is similar to that of the multivibrator the main sequence of operation is described first, where convenient in note form, and any subsidiary characteristics important for an understanding of the action, or because of particular applications of the circuits, are dealt with afterwards.

It is felt that this method of description is more readily followed once the essential principles of cumulative action and

relaxation have been grasped.

TWO VALVE CIRCUITS

2. The Multivibrator

The circuit of a Multivibrator is shown in Fig. 494. This relaxation oscillator is a two-stage resistance-loaded, capacitance-coupled amplifier with the output coupled back to the input.

The pulses produced at the anodes of the two valves are approximately rectangular (Fig. 495). In other words the oscillations produced are rich in harmonics, a fact which accounts for the name "Multivibrator".

When the circuit is first switched on a transient state follows in which both valves are conducting. After this transient period the circuit will settle down to continuous oscillations as illustrated by the waveforms of Fig. 495. Consider the interval marked (1), in which the grid voltage of valve 1 is returning towards earth. As the voltage of $1G$ rises through cut-off, the flow of current in valve 1 causes a drop of voltage at $1A$ which is applied to $2G$ through C_1 . The resulting rise of voltage at $2A$ is applied back to $1G$ and there is a further increase of current in valve 1. This process is cumulative so that the voltage of $1G$ rises rapidly to a positive value and the voltage of $2G$ falls rapidly to a value which is more negative than that required to cut off the current in valve 2. Then the action ceases.

As the voltage of $1G$ rises above zero, grid current flows, so that the grid-cathode resistance of valve 1 becomes small.

This causes the voltage rise at $1G$ to be much smaller than the corresponding fall at $2G$. (See Chap. 9 Sec. 3). The voltage at $1A$ falls momentarily below the steady value which it ultimately attains during the interval (2) because of the relatively large voltage developed initially at $1G$.

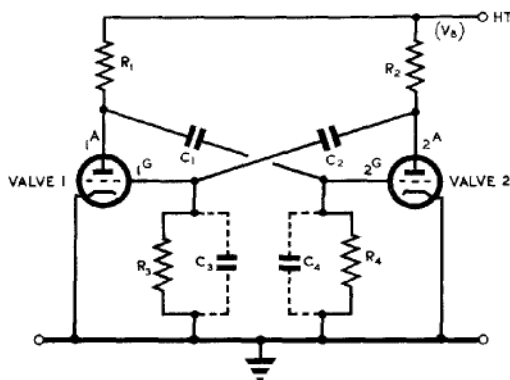

Fig. 494 - Multivibrator circuit.

After amplification has ceased the circuit relaxes, C_2 charging and C_1 discharging. The flow of grid current in valve 1 into C_2 causes the voltage at $1G$ to fall exponentially towards zero, with a time-constant approximately equal to $R_2 C_2$, while the voltage at $2A$ rises towards V_B with the same time-constant.

Meanwhile the voltage at $2G$ rises exponentially towards zero, as C_1 discharges with a time-constant which is effectively equal to $C_1 R_4$ (providing $R_4 \gg R_1$).

As the voltage at $2G$ rises through cut-off a cumulative action ensues similar to that which terminated the interval (1). This action

is concluded when the current of valve 1 is cut off.

After amplification has ceased the circuit relaxes again (interval (3), Fig. 495). The flow of grid current in valve 2 causes the voltage at 2G to fall towards zero with a time constant which is approximately equal to $R_1 C_1$, while the voltage at 1A rises towards V_B with the same time-constant. As the voltage at 2G falls the voltage at 2A rises. The voltage at 1G rises exponentially towards zero with a time-constant which is approximately equal to $C_2 R_1$, and as this voltage rises through cut-off, valve 1 re-conducts. The cycle of operation is now completed and the whole sequence repeats.

So far it has been assumed that the sudden changes in potential take place instantaneously. However, the presence of the inter-electrode and stray capacitances which are represented in Fig. 494 by C_3 and C_4 prevent any instantaneous changes. Thus, the cumulative rise of potential at the anode of valve 1 takes place with a time-constant $R_1 C_4$, whilst that at the anode of valve 2 takes place with a time-constant $R_2 C_3$. After the cumulative action is over the anode voltage of valve 1 rises during interval (3) with a time-constant $C_1 R_1$ whilst that of valve 2 rises during interval (2) with a time-constant $C_2 R_2$. In order that these rises of potential should be rapid the anode load resistances should not be too large. The rise of anode voltage may then take place in less than 1 microsecond if use is made of receiving valves of large mutual conductance. If extremely rapid action is required (0.2 microsecond) beam power valves should be used, capable of passing large currents.

The durations of the various portions of the waveforms shown in Fig. 495 depend not only upon the time-constants but also upon the minimum values of the voltages at the control grids and the cut-off voltages of the two valves. If the minimum grid voltages for valves 1 and 2 are $-1V$ and $-2V$ while the cut-off voltages are $-1V_c$ and $-2V_c$ respectively it may be shown that the periodic time of the oscillations is given by:-

$$T = C_1 R_4 \log_e \frac{1V}{1V_c} + C_2 R_3 \log_e \frac{2V}{2V_c} .$$

For a typical multivibrator, in which

$$1V = 2V = 140, \text{ and}$$

$$1V_c = 2V_c = 10,$$

this reduces to:

$$500$$

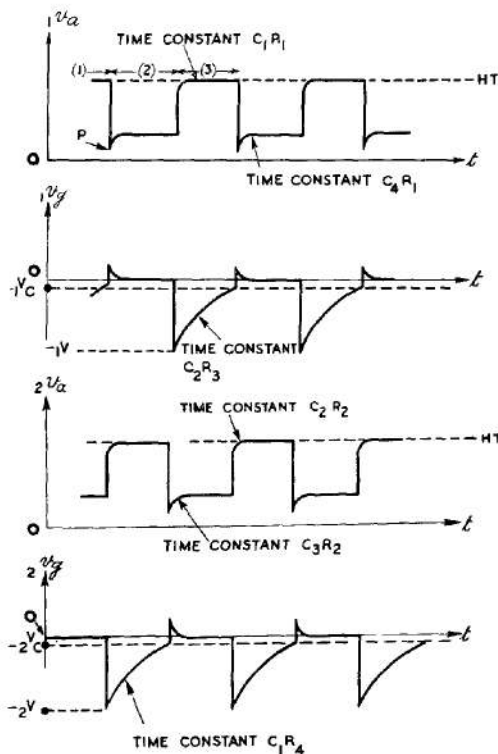

Fig. 495 - Waveforms for multivibrator circuit.

$$T = 2.6 (C_1 R_4 + C_2 R_3).$$

Hence the frequency is given by:

$$f = \frac{1}{2.6 (C_1 R_4 + C_2 R_3)}.$$

This formula is applicable only to multivibrators which operate at frequencies not greater than about 1000 c/s, since in its derivation inter-electrode and stray capacitances have been neglected.

In a symmetrical circuit the durations of the positive-going and negative-going portions of the voltage variation at either anode are equal, (Fig. 495). These portions will be of unequal duration if:-

- (i) the time-constants, $C_1 R_4$ and $C_2 R_3$ are unequal;
- (ii) valves 1 and 2 are dissimilar; or
- (iii) bias is introduced into one valve circuit only.

In radar apparatus it is sometimes necessary to change the relative durations of the positive-going and negative-going portions of the output voltage without appreciably altering the oscillation frequency. This may be accomplished, within limits, by the arrangement shown in Fig. 496. In this circuit the coupling capacitances have the same value, C . By means of a switch, the individual values R_3 and R_4 of the resistances of the two grid leaks can be altered without a change in their sum, so that the frequency:-

$$f = \frac{1}{2.6 C (R_3 + R_4)}$$

remains constant.

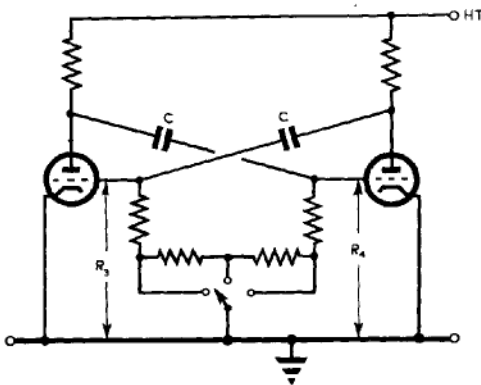

Fig. 496 - Circuit with variable mark-to-space ratio but constant frequency.

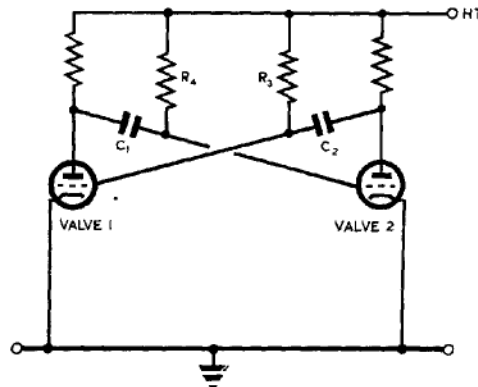

Fig. 497 - Multivibrator with leaks connected to HT line.

It is frequently advantageous to connect the grid leak resistors to a source of high positive potential rather than to earth; (Fig. 497). This causes the grid voltage of each valve to rise more sharply through cut-off so that the onset of the negative-going pulses at the anode is more clearly defined. In the circuit of Fig. 497, the time-constants $C_1 R_4$ and $C_2 R_3$ must be greater than those for the circuit of Fig. 494 if the same frequency of oscillation is desired.

If a succession of pulses, or any recurrent voltage variation, is introduced from an external source into the circuit of a multivibrator, the frequency of oscillation tends to increase until it is equal to, or is a multiple or submultiple of the frequency of the injected signal. Suppose that positive-going pulses are applied to the grid of valve 1 (Fig. 494), their frequency being slightly

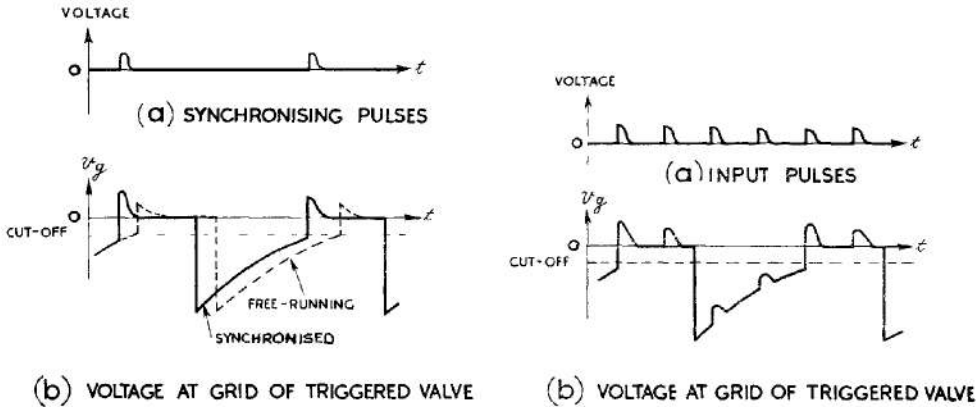

Fig. 498 - Synchronisation of a multivibrator.

Fig. 499 - Counting-down.

greater than that of the freely-running multivibrator. Fig. 498 shows the resulting variation of potential at grid 1G. When the pulse arrives 1G has not quite reached its cut-off voltage, but the application of the pulse carries it over this point, so hastening the transition to the conducting state. The multivibrator action is thus synchronised with the applied pulses. Fig. 499 shows the use of a multivibrator as a frequency divider. By a suitable choice of component values the circuit may be arranged so that it is triggered by each n -th pulse; the multivibrator frequency is then $\frac{1}{n}$ -th of the input frequency. In practice n is not usually greater than 10, although with care in adjustment it may be made as high as 50.

If only one valve is triggered in this way the duration of only the positive-going portion of its anode voltage is affected. If it is desired to control the durations of both portions of the output voltage, both valves should be triggered, e.g. by applying negative triggering pulses between the common cathode and earth.

There are several advantages in using pentodes instead of triodes in a multivibrator circuit. The presence of two additional electrodes in each valve to which pulses can be applied, or from which they can be taken, makes for greater flexibility in circuit design, and an immediate advantage is that one grid can be used exclusively for synchronising purposes. The use of pentodes also makes it possible to eliminate the peak occurring at the beginning of each negative-going portion of the anode voltage of a multivibrator (P, Fig. 495). The effectiveness of this limitation, the principle of which is discussed in Chap. 9, Sec. 4, is dependent on the anode load resistances used.

The circuit shown in Fig. 500 is that of a multivibrator using pentodes. The circuit is similar to that of Fig. 494 but the screens of the valves are used as anodes for the generation of the relaxation oscillations. Some of the space current in the conducting valve reaches the true anode and, flowing through the load resistor, provides the output voltage. In this type of circuit it is said that the anode circuits are "electron-coupled" to the remainder of the valve, as in the "Electron-Coupled" oscillator. For each valve the screen and control grid are shielded from the anode by the suppressor grid. Hence the load does not greatly affect the action of the relaxation

circuit, and the frequency of oscillation is substantially independent of changes in loading.

3. Cathode-Coupled Multivibrators

Various forms of multivibrator are in use other than the conventional type already described. Fig. 501 shows an arrangement known as a Cathode-Coupled Multivibrator. The operation of this circuit is similar to that of the conventional multivibrator and involves the same kind of

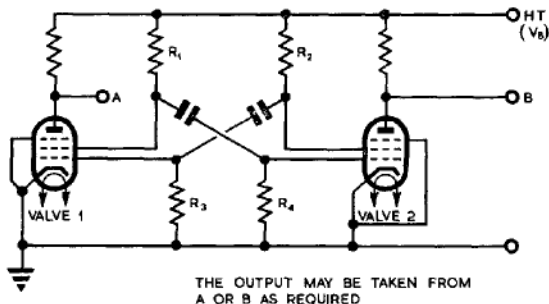

Fig. 500 - Electron-coupled multivibrator.

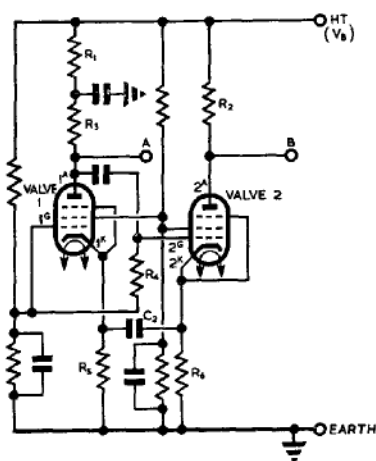

Fig. 501 - Cathode-coupled multivibrator.

THE OUTPUT MAY BE TAKEN FROM A OR B AS REQUIRED

WITH THE FOLLOWING VALUES, THIS CIRCUIT PRODUCES THE WAVEFORMS SHOWN IN FIG 502

- R1 = 24K Ω
- R2 = 36K Ω
- R3 = 165K Ω
- R4 = 1M Ω
- R5 = 20K Ω
- R6 = 100K Ω
- C1 = 0.01 μ F
- C2 = 0.03 μ F
- VALVE 1 CV1065
- VALVE 2 CV1065

cumulative action. A change in grid-cathode voltage gives rise to a chain of events resulting in a similar but amplified voltage variation being added to the voltage between grid and cathode so that the circuit is unstable.

A brief explanation of the action is given below in note form.

Assume valve 2 to be conducting and the current in valve 1 to be cut off, (interval (1) Fig.

502). The voltage at 1K falls as C₂ discharges. As the voltage at 1K approaches that of 1G valve 1 starts to conduct.

The subsequent behaviour is as follows:-

- The voltage at 1A falls (after amplification in valve 1).
- " " " 2G " "
- " " " 2K " (as in a cathode follower).
- " " " 1K " still further, so that the action is cumulative.

This action is terminated when the current in valve 2 is cut off.

Interval (2)

C₂ discharges as 2K returns towards earth potential in the absence of current in valve 2.

As the voltage at 2K approaches that of 2G valve 2 starts to conduct.

The voltage at 2K rises.

The voltage at $1K$ rises.
 " " " $1A$ "
 (after amplification in
 valve 1).
 The voltage at $2G$ rises.
 " " " $2K$ "
 still further so that
 the action is again
 cumulative.

This action is
 terminated when the
 current in valve 1 is
 cut off.

Interval (3)

C_2 charges
 as $1K$ returns towards
 earth potential and
 the action repeats.

It has been
 assumed that no appreciable
 change occurs in the
 voltage at $2G$ during the
 intervals between the
 transitions from one state
 to the other. This
 assumption is justified
 if $C_1 R_4$ is large com-
 pared with the period of
 oscillation.

An essential
 feature of the operation
 is that the cathode load
 resistors of the two valves
 are unequal, so that when
 valve 1 is conducting $1K$
 is at a lower potential
 than $2K$ when valve 2 is
 conducting. It is the
 charging and discharging
 of C_2 through this
 potential difference
 which determines the
 period of oscillation.

The time-constant which determines the duration of interval
 (2) is approximately $C_2 R_6$, (neglecting the output resistance of the
 cathode circuit of valve 1).

The time-constant which determines the duration of interval
 (3) is approximately $C_2 R_5$ (neglecting the output resistance of the
 cathode circuit of valve 2). The frequency is thus approximately
 proportional to

$$\frac{1}{C_2 (R_5 + R_6)}$$

and the mark-to-space ratio depends on the ratio R_5/R_6 . However, if
 the values of R_5 and R_6 are altered, the amplitudes of the voltage
 variations at the cathodes are changed so that the voltage developed
 across C_2 is affected. For this reason if it is desired to change

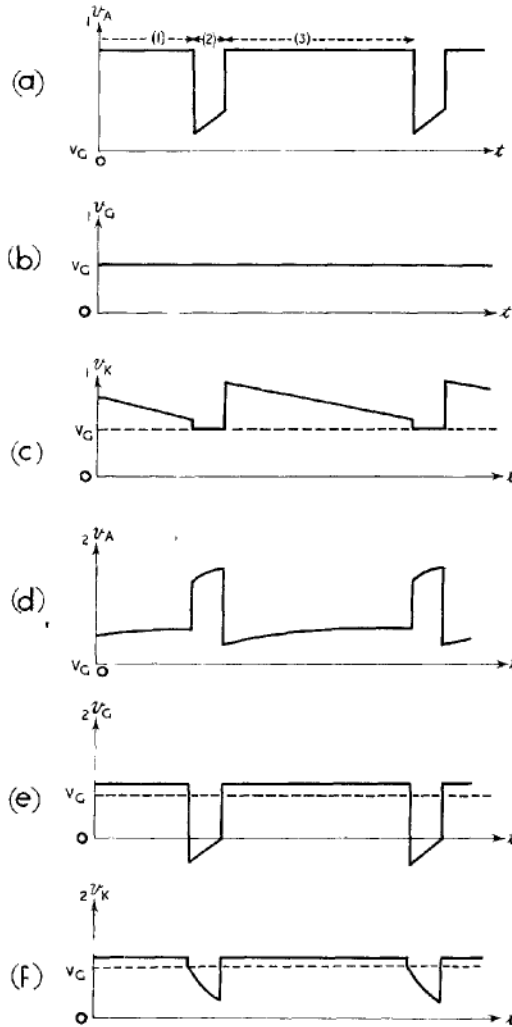

Fig. 502 - Waveforms for cathode-coupled multivibrator.

the mark-to-space ratio by changing the ratio R_5/R_6 , some further adjustment must be made if the frequency of oscillation is to remain the same. This may take the form of an alteration to the value of R_3 .

Since the control grids are maintained at a high positive voltage, only a small portion is utilised of the exponential fall of either cathode towards earth. This ensures that the instants at which cumulative action occurs are clearly defined.

An alternative form of cathode-coupled multivibrator is shown in Fig. 503; the waveforms for this circuit are given in Fig. 504. The relaxation times are determined by the charging of C_2 through R_1 and the discharging of C_3 through R_3 . In this case the asymmetry in the cathode circuits is provided by the resistor R_5 .

In some cathode-coupled multivibrators of this type the asymmetry which is essential for the operation is afforded by the use of valves which are of different current-carrying capacities.

4. Relay Circuits

If the bias voltage applied to one of the valves of a multivibrator is made sufficiently negative the circuit becomes so unbalanced that it is no longer

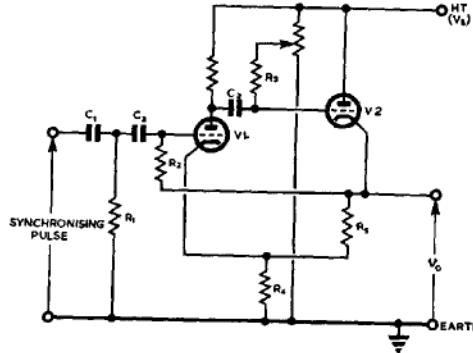

Fig. 503 - Alternative form of cathode-coupled multivibrator.

I_1 = CURRENT THROUGH VALVE 1 AT ZERO BIAS
 I_2 = CURRENT THROUGH VALVE 2 AT ZERO BIAS

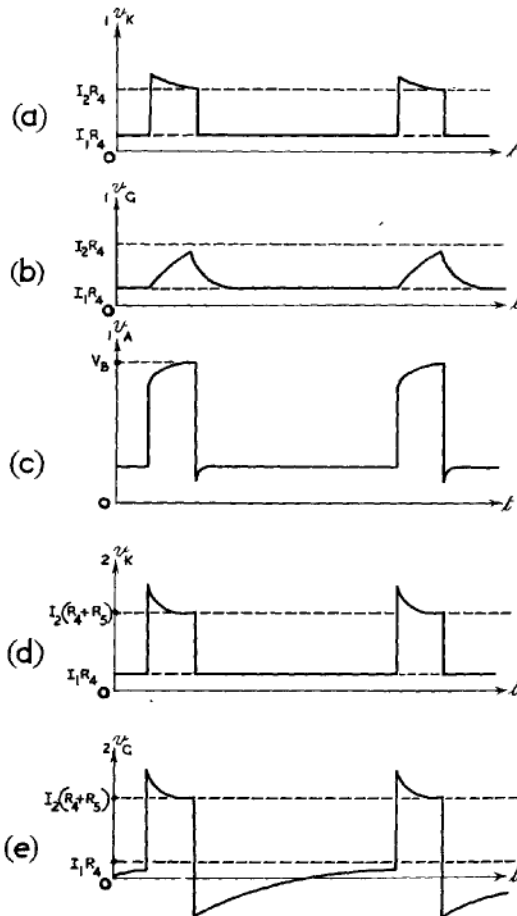

Fig. 504 - Waveforms for alternative form of cathode-coupled multivibrator.

free-running. The circuit then operates as a relay, the stable state being that in which the unbiased valve is conducting. The circuit can be triggered from the stable to the unstable state by the leading edge of an applied pulse, which causes the biased valve to conduct. The subsequent action is similar to that of a multivibrator except that after the biased valve has again become non-conducting it remains in this condition until a further triggering pulse is applied.

In general a relay is used for the production of rectangular pulses of comparatively long duration and large amplitude compared with the duration and amplitude of the applied pulses. The nature of each output pulse is normally not dependent upon the amplitude or duration of the triggering pulse, provided the latter is sufficiently large to initiate the action.

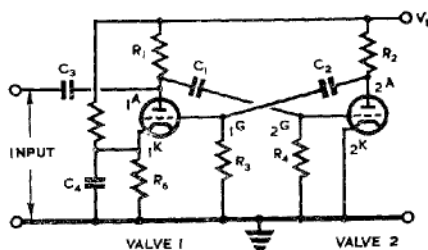

Fig. 505 - Two-valve relay.

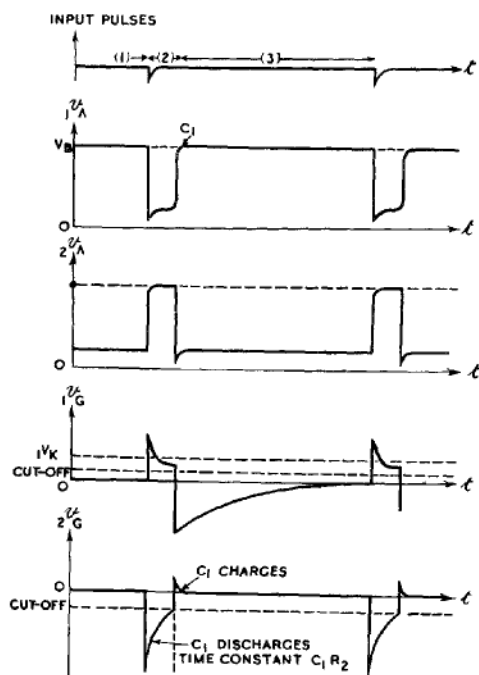

Fig. 506 - Action of two-valve relay.

action is thus cumulative.

This transition ceases when the current in valve 2 is cut off.

Interval (2)

C_1 discharges as $2G$ returns towards earth potential. As the voltage at $2G$ rises through cut-off, anode current flows in

Fig. 505 shows a possible circuit arrangement of a relay. The circuit is essentially that of the multivibrator, but valve 1 is biased so that the current in this valve is normally cut off, whereas valve 2 is unbiased. Initially, therefore, the anode voltage of valve 1 is at HT (V_b), while the anode voltage of valve 2 is at a low level (Interval (1) Fig. 506).

Assume that the relay is triggered by a negative-going pulse applied to the anode $1A$ of valve 1 (i.e., to the grid $2G$ of valve 2). The subsequent behaviour is as follows:-

- The voltage at $2G$ falls.
- " " " $2A$ rises.
- " " " $1G$ rises
- by an amount sufficient to cause valve 1 to conduct.
- The voltage at $1A$ falls still further, and the

valve 2:-

The voltage at 2A falls.
 " " " 1G " "
 " " " 1A rises.
 " " " 2G "

still further, and the cumulative action ceases when the current in valve 1 is cut off.

Interval (3)

C₂ discharges as 1G returns towards earth potential. Valve 1 remains cut off by the bias developed across R₆.

The duration of interval (2) depends on the time-constant C₁ R₄ (assuming R₄ >> R₁). The other time-constant C₂ R₂ must be sufficiently long to prevent any substantial change in the voltage at 1G during the interval (2), but short compared with the interval (3) so that the circuit returns to its initial state before the next triggering pulse is applied. If the latter condition is not satisfied the circuit does not respond to the next pulse, and counting-down occurs (Sec.2).

The time-constant of the discharge of C₂ can be considerably reduced by the insertion of a diode between 1G and earth, with its cathode connected to 1G.

The relay may also be triggered by the application of a positive-going pulse to 2A or 1G. If this method is employed a larger pulse is necessary since the amplification afforded by valve 2 is dispensed with.

The method of triggering indicated in Fig. 505 has the additional advantage that as soon as valve 1 conducts the input resistance of the anode circuit is low, so that the normal operation of the relay is not likely to be affected by the trailing edge of the triggering pulse.

Secondary effects occur similar to those which arise in the case of the multivibrator; these are indicated in the waveforms of Fig. 506.

Fig. 507 shows an alternative method of biasing. The current flowing in valve 2 develops across the common cathode resistor a bias voltage sufficiently large to ensure that the current in valve 1 is cut off in the absence of a triggering pulse.

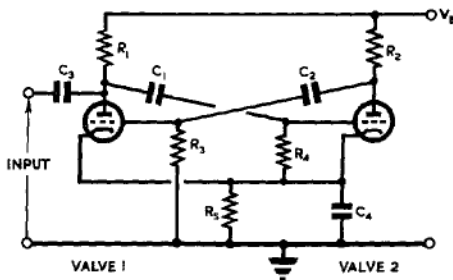

Fig. 507 - Two-valve relay with alternative biasing arrangement:

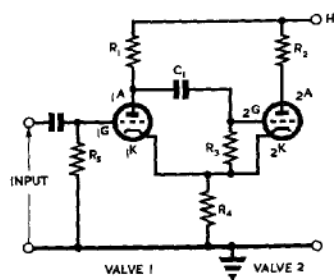

Fig. 508 - Cathode-coupled relay.

In both circuits the onset of the trailing edge of the output pulse is more clearly defined if the grid leak R₄ is connected to the HT supply instead of to the cathode (compare Sec. 2).

Fig. 508 shows the circuit of a cathode-coupled relay and Fig. 509 shows waveforms at points of special importance. The action is similar to that of a cathode-coupled multivibrator. It is essential for the relay action that the current flowing in valve 2 when conducting is greater than that in valve 1 when valve 1 is conducting. This may be ensured by using different valves, or by making $R_1 > R_2$.

The action is as follows:-

Interval (1)

Valve 1 current cut off, valve 2 conducting. A positive triggering pulse causes valve 1 to conduct.

Voltage at $1A$ falls, " " $2G$ " ; Current in valve 2 is reduced.

The current flowing through R_1 decreases, since valve 1 does not conduct as heavily as valve 2.

Hence the voltage at $1K$ decreases. Current through valve 1 increases.

The voltage at $1A$ falls still further, so that the action is cumulative, ceasing when valve 2 current is cut off.

Interval (2)

C_1 discharges; as the voltage at $2G$ rises through cut-off:-

Current flows in valve 2.

Voltage at both cathodes rises.

Current in valve 1 is reduced.

Voltage at $1A$ rises.

Voltage at $2G$ rises, the cumulative action ceasing when the current in valve 1 is cut off.

Interval (3)

As the voltage at $2G$ rises above that of $2K$ grid current flows and C_1 charges rapidly as the relay resumes its stable state.

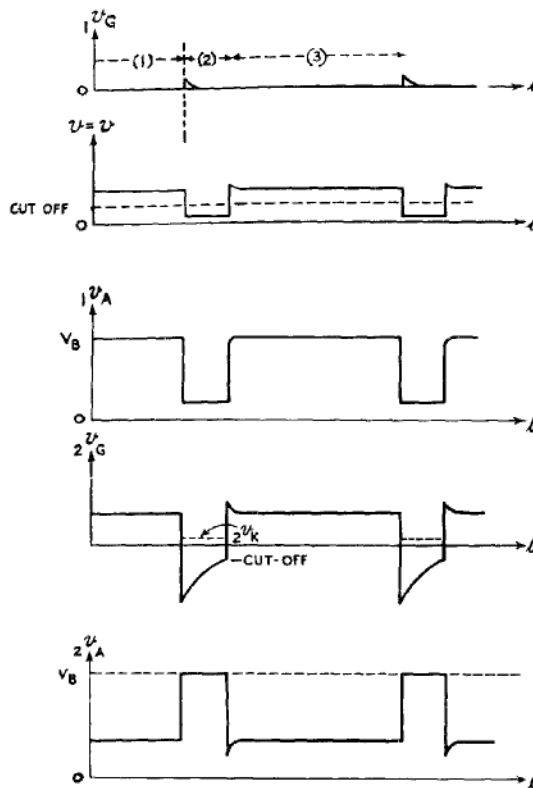

Fig. 509 - Waveforms for cathode-coupled relay.

ONE-VALVE CIRCUITS5. Transitron Circuits

A single multi-electrode valve such as a pentode may be used to generate voltage variations by a mode of operation similar to the action of two-valve relaxation oscillators and relays. Under certain conditions the space charge between screen and suppressor grids of a pentode can act as a virtual cathode, so that variation of the suppressor grid potential can be used to control the anode current. In these circumstances, this virtual cathode, together with the anode and suppressor grid, can operate as one triode valve, whilst the true cathode, control grid and screen grid act as another. In this manner one valve may be made to fulfil the functions of the two valves in the circuits already described. The essential similarity between the one-valve and two-valve circuits will be seen in the circuit diagrams as soon as the principle is grasped of treating the pentode as a pair of triodes. There are, however, one or two characteristics which apply particularly to Transitrons, as one-valve circuits of this type are called:-

- (i) There is inherent in the circuit, but only for certain values of anode, suppressor and screen voltages, a mutual interaction between anode and screen grid. So long as a virtual cathode is present, a reduction in anode voltage diminishes the anode current and causes an increase in screen current. This leads to a fall in screen voltage due to the increased current through the screen load or dropping resistance. On the other hand, the converse is not true; a reduction in screen voltage diminishes both the anode and screen-grid currents, so that the anode voltage rises due to the decreased current through the anode load.
- (ii) In the two-valve circuits the two stable or unstable conditions occur when, in turn, each valve is conducting while the other is out-off. One of the conditions arising in the transitron is similar, namely that in which the anode current is cut-off by suppressor grid action. No condition can arise, however, in which screen current is cut off, since this would imply that the anode current were cut off, too. Instead, the two states may be distinguished by the screen-voltage levels. When anode current flows, the screen current is small and the screen voltage high; when anode current is cut-off, screen current is large and the screen voltage is low. Relaxation oscillations or relay actions take the form of transitions from one of these states to the other and back again.
- (iii) As described in Chap. 6 Sec. 34, and illustrated in Fig. 300(a), for certain values of anode and suppressor voltages a rise in voltage at the suppressor grid leads to a decrease in screen current; so that if the screen load is not decoupled the screen voltage rises. An essential feature of transitron circuits is that the screen and suppressor grids are coupled by a condenser so that over this region of the valve characteristics (B to C, Fig. 300(a)) the action of the circuit is cumulative. A rise in suppressor voltage causes a rise in screen voltage due to the electronic action in the valve, and this in turn causes the suppressor voltage to rise still further due to the coupling circuit. A similar cumulative action follows a fall in suppressor voltage over the same region.

It should be borne in mind that whether this cumulative action

can occur or not depends on the potentials of the other electrodes in the valve; in particular, that of the anode needs to be low.

- (iv) If a feed-back resistor is included in the cathode lead this acts in a manner similar to that of the common cathode resistor of a cathode-coupled multivibrator or relay. When anode current flows the bias developed across this resistor is likely to be much greater than when the anode current is out-off by suppressor grid action.

6. Transitron Relaxation Oscillator

Transitron Relaxation Oscillators are not in normal use in radar equipment since in general they are less stable, and also less flexible in design than the two-valve circuits. However, one arrangement, known as the Fleming-Williams circuit, is suitable as a free-running generator of sawtooth voltages.

The circuit arrangement is shown in Fig. 510. The wave-forms of the voltages at the various electrodes are shown in Fig. 511.

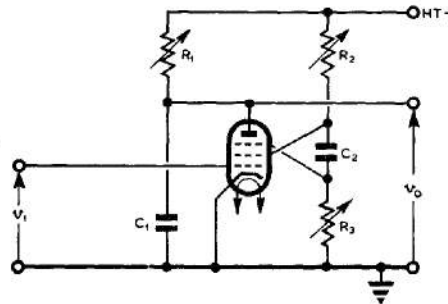
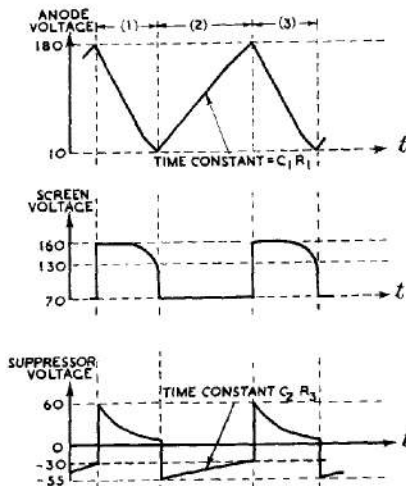

Fig. 510 - Transitron relaxation oscillator.

The action is as follows:-

Interval (1)



VALUES OF COMPONENTS USED:-
 $R_1 = 100k\Omega$ $R_2 = 500k\Omega$ $R_3 = 250k\Omega$
 $C_1 = 0.1\mu F$ $C_2 = 1\mu F$

THE VALVE IS A CV1091 WITH A HT SUPPLY OF 350 VOLTS

Fig. 511 - Action of transitron relaxation oscillator.

Anode current is flowing so that the screen voltage is at the higher of its two levels of operation. C_1 discharges as the anode voltage falls. The suppressor voltage falls from a positive value. As the anode voltage falls a virtual cathode begins to form between screen and suppressor grids and a state is eventually reached at which the cumulative action described in Sec.5 (iii) is initiated. The fall in suppressor voltage causes a fall in screen voltage and because of the coupling circuit formed by C_2 and R_3 the suppressor voltage is further reduced. This cumulative action ceases when the anode current is cut off (see Fig.511).

The voltage at G_2 has then fallen to the lower of its two levels of operation (Fig. 511).

Interval (2)

C_2 discharges and the voltage at G_3 rises exponentially towards zero with a time constant approximately $C_2 R_3$ ($R_2 \ll R_3$). At the same time C_1 charges through R_1 and the anode voltage rises. A point (suppressor-grid cut-off) is reached at which anode current starts to flow, so that the screen current decreases. Hence:-

The voltage at G_2 rises.
 " " " G_3 rises;

this further increases the anode current and reduces the screen current so that the action is cumulative.

This cumulative action ceases when the virtual cathode between G_2 and G_3 disappears (the anode voltage is now high), so that a further rise in the potential of G_3 has negligible effect on the anode current. This occurs when the voltage at G_3 is in the region of zero potential. However, the voltage at G_3 is raised considerably above zero by the rise in screen voltage.

Interval (3)

C_2 charges and the voltage at G_3 falls towards zero. The anode voltage falls as C_1 discharges and the cycle of operation repeats.

The oscillations may be synchronised satisfactorily by the application of either positive pulses to the suppressor grid or negative pulses to the control grid. In either case the applied pulse initiates the cumulative action from interval (2) to interval (3) (Fig. 511).

7. Transitron Relay

In the circuit depicted in Fig. 512, the components are chosen so that a stable state exists in which there is no virtual cathode between screen and suppressor grids; this is done by making the anode load sufficiently small. Alternatively, a stable state can be obtained if the suppressor grid is connected to a source of voltage sufficiently negative to prevent anode current from flowing. The condenser C_1 of Fig. 510 is omitted from the relay circuit when a rectangular output voltage is required at the anode. The relay may be triggered by either a positive-going or a negative-going pulse of small amplitude applied either to the control grid G_1 or to the suppressor grid G_3 . A larger triggering pulse is needed at G_3 than will suffice at G_1 .

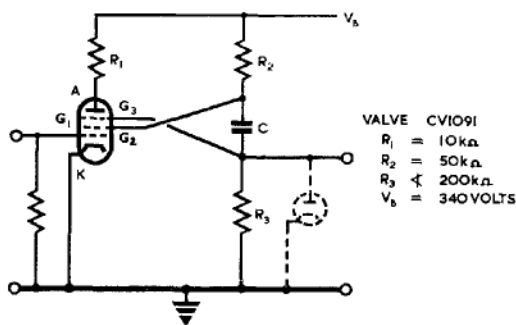

Fig. 512 - Transitron relay.

Fig. 513 illustrates the action following the application of a small positive pulse to G_1 . Initially, during the interval (1), anode current is flowing and the suppressor grid is at zero potential.

Interval (1)

As the voltage at G_1 rises:-

the space current increases, the voltage at G_2 falls, " " " G_3 falls, the anode current is reduced and the voltage at A rises.

The reduction in anode current is accompanied by a further increase in screen current causing the voltage at G_2 to fall still further.

This cumulative action ceases when the anode current is cut off so that all the space current flows to the screen.

The screen current decreases and the voltage at G_2 and G_3 rises as the input voltage at G_1 returns to zero; but provided the fall in voltage at G_2 and G_3 during the cumulative action is large enough, the anode current remains cut-off by the negative voltage at G_3 .

Interval (2)

C discharges with time-constant approximately CR_3 , ($R_3 \gg R_2$).

The voltage at G_3 rises towards zero.

At a certain value (suppressor-grid cut-off) anode current begins to flow.

The voltage at A falls.

The increase in anode current is accompanied by a reduction in screen current causing the voltage at G_2 to rise.

This causes a further rise in the voltage at G_3 so that the action is cumulative and the relay returns to its stable condition (interval (3)).

Since the suppressor voltage rises above zero due to the rise in screen voltage, suppressor current flows and C charges rapidly.

This flow of current through R_2 causes the irregularity shown in the anode and screen-grid waveforms at the trailing edge of the output pulse (beginning of interval (5)).

The response of the circuit to a negative triggering pulse applied to screen or suppressor grid is essentially the same as in the case described above.

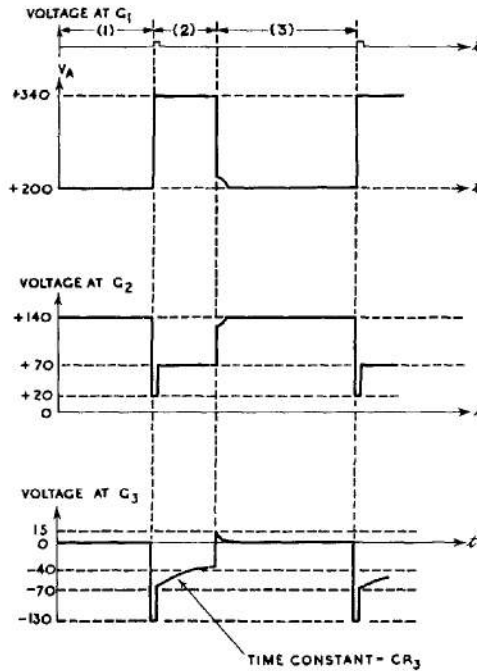

Fig. 513 - Action of transitron relay: positive triggering pulses.

The effect of applying a negative triggering pulse to the control grid is illustrated in Fig. 514. No cumulative action follows the initial fall in voltage; this merely results in amplification at screen and anode as shown in the diagram, the voltage at the suppressor grid G_3 rising with the screen voltage. However, provided the triggering pulse is of sufficient amplitude or duration, the condenser C charges, due to suppressor current flowing. Due to this charging of C , the fall in screen voltage at the end of the applied pulse carries the suppressor voltage below zero potential, initiating the same cumulative action as was described with reference to the response of the relay to a positive triggering pulse. The remainder of the action is identical with that which follows in the former case.

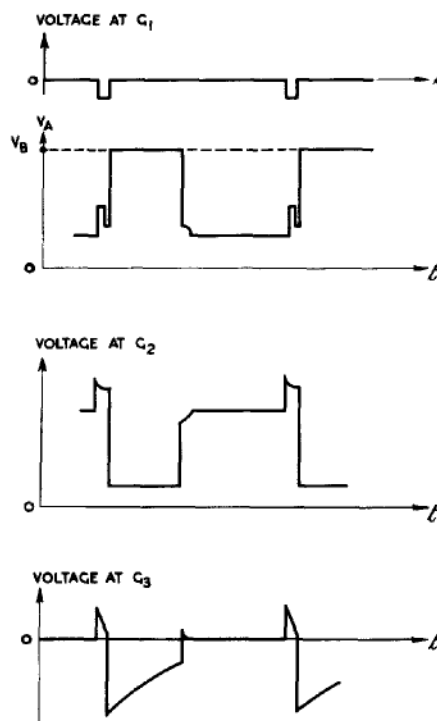

Fig. 514 - Action of transitron relay : negative triggering pulse.

If the initial rise of suppressor grid voltage is very large the effects described may be offset by the flow of reversed suppressor current.

In some pentodes (e.g. CV1091) this may occur when the suppressor grid is about 40V above that of cathode. In such a case the net effect of the pulse applied to the control grid is to cause the condenser C to discharge rather than charge, and no cumulative action can occur. This effect can be eliminated by inserting a diode between G_3 and cathode, with the anode connected to G_3 , as shown by the dotted lines in Fig. 512. The emission of electrons from the diode cathode is likely to exceed considerably any secondary emission from the suppressor grid, so that the charging of C is ensured.

The response of the relay to a positive triggering pulse applied to the screen or suppressor grids is similar to the case just described.

In all cases the duration of the output pulse, positive-going at the anode and negative-going at the screen, depends upon the time-constant CR_3 . Owing to the large value of screen resistor necessary for the operation of the relay it is not normally practicable to take the output from the screen grid unless it is to be applied to a circuit with a correspondingly high input resistance and low input capacitance. No such limitations normally apply to the anode circuit, where the output resistance is small.

Owing to the fact that valves are not normally manufactured to give precise suppressor-grid characteristics the behaviour of a transitron circuit may vary considerably if different valves, even of the same type, are used. For this reason two-valve circuits are frequently to be preferred.

8. The Blocking Oscillator

The Blocking Oscillator is a form of relaxation oscillator

which is used primarily as a generator of rectangular pulses. The duration of the output pulses is normally of the order of 10 - 100 microseconds. The principle of the blocking oscillator is similar to that of the self-quenching oscillator, described in Chap. 8 Sec. 47. (It is common American practice to use the same term Blocking Oscillator for both types of circuit.) In the blocking oscillator the regeneration is sufficient to ensure that the valve current is out off before a single cycle is completed.

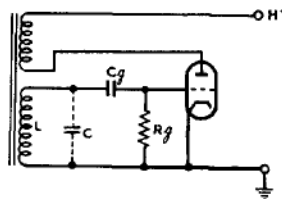

Fig. 515 - Blocking oscillator.

The circuit arrangement of one form of blocking oscillator is shown in Fig. 515. The waveforms for this circuit are given in Fig. 516.

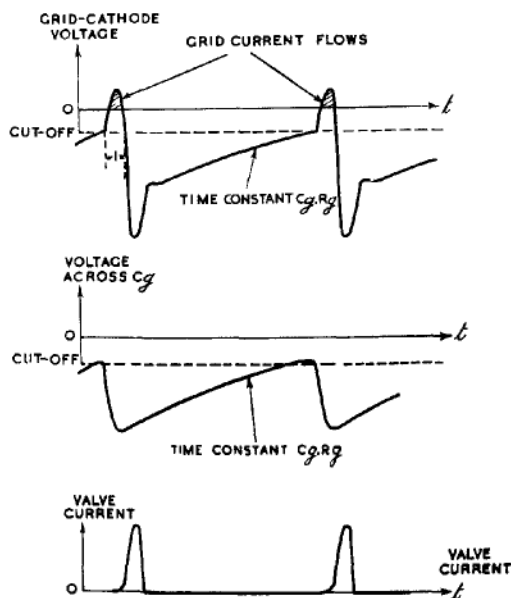

Fig. 516 - Blocking oscillator waveforms.

Although the circuit diagram is similar to that of a tuned grid oscillator the effective "tuned circuit" is much more complex. No tuning capacitance is used, and the inductance of the grid coil in parallel with its stray capacitance forms a ringing circuit. When grid current flows this circuit is heavily damped and is shunted by the series arm formed by C_g and the grid-cathode resistance. The period of oscillations in the grid circuit is thus considerably increased by the flow of grid current.

Two essential conditions of operation of the circuit are:-

- (i) The coupling between output and input circuits must be very tight, so that the grid voltage is forced to a high positive level at the beginning of the cycle (period (1)). This ensures a large flow of grid current to charge the bias condenser C_g .
- (ii) Although the time-constant $C_g R_g$ must be large, so that there is an appreciable interval of relaxation between the output pulses, C_g must be small. This ensures that the bias voltage developed across C_g acquires a large negative value before the end of the positive pulse at the grid.

If the bias is not large enough, subsequent free oscillations in the grid circuit may raise the grid voltage above cut-off again.

The relaxation time is determined by the maximum value of the bias and by the time-constant $C_g R_g$. Since the duration of the pulse is normally much shorter than the relaxation time, the latter is the main factor in determining the repetition period.

The duration of the output pulse depends on the value of the inductance and the various capacitances and resistances associated with

the grid circuit. It may be reduced by:-

- (i) reducing the effective inductance;
- (ii) reducing the capacitance C_g ;
- (iii) increasing the flow of grid current, e.g. by the use of a valve with greater cathode emission.

The grid leak may be connected to a positive supply instead of to earth. In this case the grid voltage rises towards a positive potential so that the instant at which valve current starts to flow is more precisely determined than when the grid voltage rises towards zero (see Chap. 8, Sec. 47).

The blocking oscillator may be readily synchronised by a positive-going pulse applied to the grid; alternatively, the time-constant may be adjusted so that counting-down occurs.

An alternative form of the blocking oscillator circuit is shown in Fig. 517, where an electron-coupled Hartley Oscillator is used (see Chap. 8, Sec. 8). In this case the effective inductance of the grid circuit depends, among other things, on the value of the damping resistor R , in the primary circuit. A decrease in R reduces the effective inductance and increases the damping, so that the amplitude and duration of the output pulses are reduced. The decrease in amplitude causes an increase in recurrence frequency. The recurrence frequency may also be varied more or less independently of the duration of the pulses by altering the value of the grid leak.

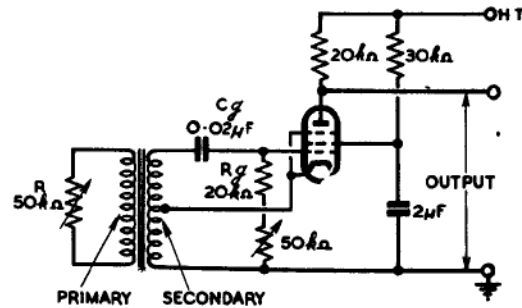

Fig. 517 - Alternative form of blocking oscillator.

With the component values shown in the figure, the duration of the negative-going pulses at the anode is of the order of 15 microseconds, and the repetition frequency can be varied from about 500 c/s - 2000 c/s.

Blocking oscillators are frequently used with the automatic biasing network in the cathode circuit. In circuits of this type it is not practicable to use a very large resistance in the cathode lead, so that the condenser must be made larger than in the grid-biasing circuits in order to provide a long time-constant for the discharge or relaxation interval. This increase in the circuit capacitance tends to cause the output pulse to be of longer duration in the cathode-biased oscillators than in the grid-biased circuits.

More complicated circuits may be designed to make the recurrence frequency substantially independent of fluctuations in supply voltage. These arrangements generally incorporate a ringing circuit, the period of which is unaffected by changes in supply voltage. This technique constitutes a marked departure from the "relaxation" method of determining time-intervals.

CIRCUITS EMPLOYING THE MILLER TIME-BASE PRINCIPLE

9. General

The circuits discussed in the remaining sections of this chapter employ the method used in the Miller Time-Base Circuit of generating linear voltage variations. This principle is dealt with in detail in Chap. 11 Sec. 10. It involves the use of a pentode with a condenser connected between anode and control grid. The valve is controlled externally by the voltage at its suppressor grid. When this voltage is such as to allow anode current to flow, the anode voltage falls as the condenser discharges. The anode "run-down" is very nearly proportional to time. In the Miller time-base circuit some additional control device is needed for releasing and resetting the valve, and also for maintaining a constant voltage at its suppressor grid during the run-down interval.

In the circuits about to be described the principle of the Miller time-base is embodied in a relay action. These circuits are at present described by rather fanciful names, which have no scientific connotation. In the case of the Sanatron, a second valve is used for controlling the Miller valve in response to an externally applied triggering pulse. In the Phantatron circuit a single pentode valve is used to fulfil the double functions of control and Miller valve. Many variants of these circuits are used, either as relays or as relaxation oscillators, but only the two principal circuits are described here.

10. The Sanatron

A simplified circuit diagram of this relay is given in Fig. 518. An outline of the action is as follows:-

Initially valve 2 is conducting, while the anode current of valve 1 is cut off by the negative bias on its suppressor grid $1G_3$. A negative triggering pulse is applied to the suppressor grid $2G_3$ of valve 2. This is of sufficient amplitude to cut off the anode current in valve 2.

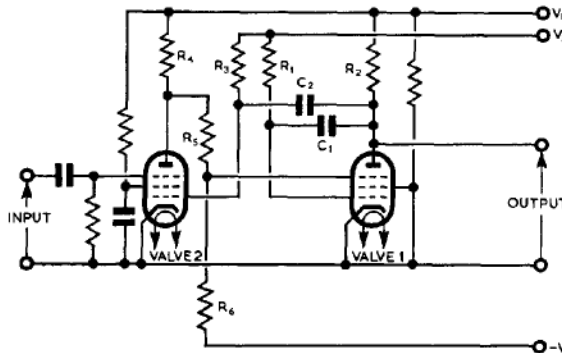

Fig. 518 - Simplified sanatron circuit.

Voltage at $2A$ rises.
Voltage at $1G_3$ rises.

Thereafter, while the anode current in valve 2 remains cut off, these voltages are held at steady values by the potentiometer chain between V_B and $-V_1$.

As the voltage at $1G_3$ rises towards a positive value, anode current flows in valve 1, causing an instantaneous fall in anode voltage followed by a constant rate of collapse. This fall in voltage at $1A$ is communicated to the control grid $2G_1$ via the network $C_2 - R_3$ and is sufficient to cut-off the current in valve 2. The rate of collapse of anode voltage is given, as in the Miller time-base generator, by

$$- \frac{dV_A}{dt} = \frac{V_2}{C_1 R_1}$$

At the end of the run-down at $1A$, the anode voltage "bottoms", C_2

discharges, and the voltage at $2G_1$ returns towards V_2 . As this voltage rises through cut-off, valve 2 reconducts:-

The voltage at $2A$ falls.
 " " " $1G_3$ " "
 " " " $1A$ rises.
 " " " $2G_1$ "

still further so that the action is cumulative.

This cumulative action ceases when the anode current in valve 1 is out-off.

C_1 and C_2 recharge as the voltage at $1A$ returns to V_B , and the circuit reverts to its initial state.

Fig. 519 shows a practical form of the sanatron circuit, and the waveforms of the voltages at the electrodes are shown in Fig. 520.

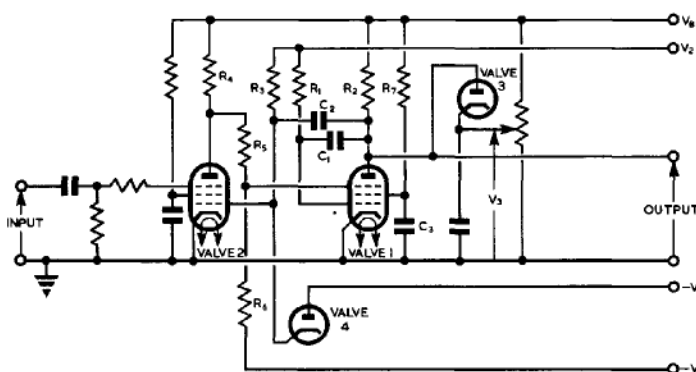

TYPICAL VALUES OF COMPONENTS

$R_1 = 70k\Omega$	$C_1 = 100\mu F$	$V_B = 300V$
$R_2 = 500k\Omega$	$C_2 = 100\mu$	$-V_1 = -320V$
$R_3 = 150k\Omega$	$C_3 = 0.5\mu F$	$V_2 = 200V$
$R_4 = 15k\Omega$		$-V_4 = -5V$
$R_5 = 100k\Omega$		
$R_6 = 250k\Omega$		
$R_7 = 12k\Omega$		

Fig. 519 - Practical sanatron circuit.

A diode, valve 3, is included to limit the anode voltage of valve 1. During the recharging period the anode voltage returns towards V_B but as the diode conducts is clamped at the level V_3 , determined by the setting of the potentiometer slider P. This diminishes the recovery time of the Miller valve (interval (3)). The amplitude, and hence the duration, of the output pulse can be controlled by the potentiometer setting.

A second diode, valve 4, limits the negative excursions of the grid of valve 2 to a value $-V_4$, just sufficient to ensure that valve 2 is out-off (about -5 volts). This reduces the interval (4) between the end of the run-down and the instant at which valve 2 reconducts.

It may be noted that the same rapid fall of voltage at $1A$ during interval (2) is communicated to the control grids of both valves. This is sufficient to cut off the current in valve 2, but not in valve 1. Hence if the valves are otherwise alike, they must be adjusted so that the cut-off voltage is lower for valve 1 than for valve 2. This may be accomplished by using a larger screen dropping resistance for valve 2.

Alternative methods of triggering, which utilise the amplification of valve 2, may be employed. The method already described, using a negative pulse applied to the suppressor grid, requires a triggering pulse amplitude of about 60V. If a negative-going pulse is applied to $2G_1$, or to $1A$ (actually to the cathode of the diode, valve 3) an amplitude of about 15 volts is sufficient. If the grid-triggering method is employed an additional diode is

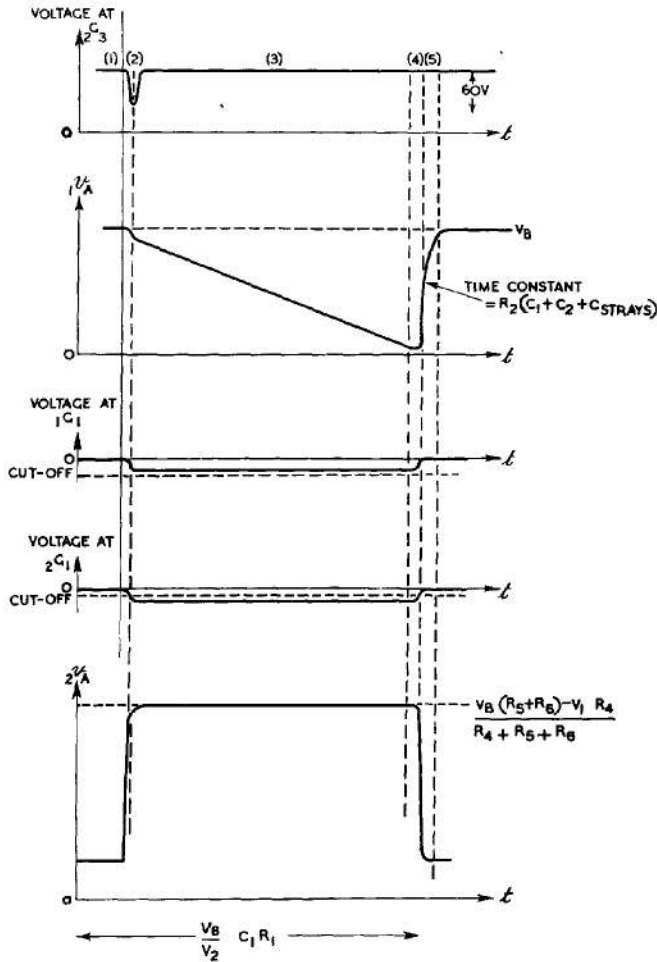

Fig. 520 - Action of sanatron circuit.

necessary, as shown in Fig. 521, to prevent the trailing edge of the triggering pulse from causing the valve to re-ignite. If triggering pulses are applied to the cathode of valve 3 a cathode load resistor must be inserted, since in the circuit of Fig. 519, the cathode is decoupled to earth.

Some advantages may be derived from the use of the screen grid of valve 1 as a control electrode in place of the suppressor grid, particularly if a very fast run-down is required. The rate of collapse of anode voltage is limited by the anode current, which depends on the screen voltage, and high values of screen voltage lead to excessive screen dissipation. The fact that the screen is held at a low voltage except during the run-down interval reduces the screen dissipation and allows a higher screen voltage to be used, so that a faster run-down may be achieved.

The modifications which are needed to the arrangements of Fig. 519 to convert the circuit to one using screen-grid control are shown in Fig. 522. This method of controlling the Miller valve allows the use of a beam tetrode in place of a pentode, so that larger values of anode current are available for the same screen dissipation. This further increases the permissible run-down speed.

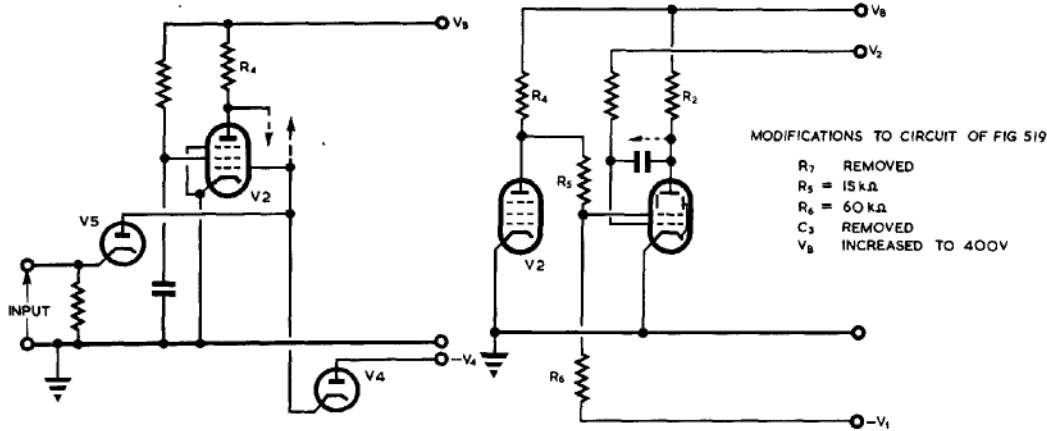

Fig. 521 - Sanatron circuit: control grid triggering.

Fig. 522 - Sanatron circuit: screen grid control.

11. The Phantastron

The Phantastron is a one-valve relay, similar in action to the two-valve Sanatron circuit. A simplified diagram of a phantastron circuit is shown in Fig. 523. The anode and control grid are connected by the condenser which typifies the Miller time-base arrangement. The suppressor grid and cathode connections give rise to the cumulative action which operates the relay.

Initially, the control grid is limited at cathode potential by grid current flowing through R_1 . The cathode voltage is held at 20 or 30 volts above that of the suppressor grid by the current through R_3 , so that anode current is cut off by the suppressor grid bias. The valve current flowing through R_3 is therefore due entirely to screen and control grid currents.

A negative-going triggering pulse is applied to G_1 . The cathode voltage falls (cathode follower action).

The cathode voltage is lowered relative to that of the suppressor grid by an amount sufficient to cause anode current to flow, i.e. the suppressor grid-cathode voltage is raised above cut-off.

As anode current flows the anode voltage falls.

This fall is communicated to G_1 via the condenser C.

The cathode voltage falls still further, so that the action is cumulative.

Hence, even when the triggering pulse is removed, anode current continues to flow, and the circuit remains temporarily in its unstable state.

The anode run-down then follows, as in the Miller time-base. No appreciable change in voltage at control grid or cathode occurs until the anode voltage bottoms. The voltage at G_1 then begins to rise more steeply, and with it the voltage at the cathode. This rise in cathode voltage with respect to that of the suppressor grid reduces the anode current.

This causes the anode voltage to rise, and with it the voltage at G_1 .

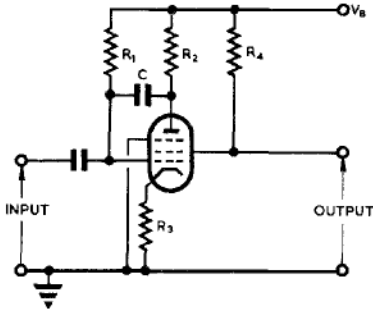

Fig. 523 - Simplified phantastron circuit.

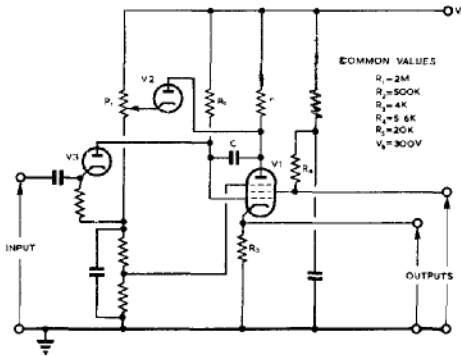

Fig. 524 - Practical phantastron circuit.

The cathode voltage rises still further, so that the action is cumulative, ceasing when the anode current is cut off. C then discharges and the circuit reverts to its initial condition.

A practical phantastron circuit is given in Fig. 524, and the waveforms of the voltages at the various electrodes are shown in Fig. 525. The function of the diode in the anode circuit (valve 2) is the same as that of the corresponding diode in the sanatron circuit,

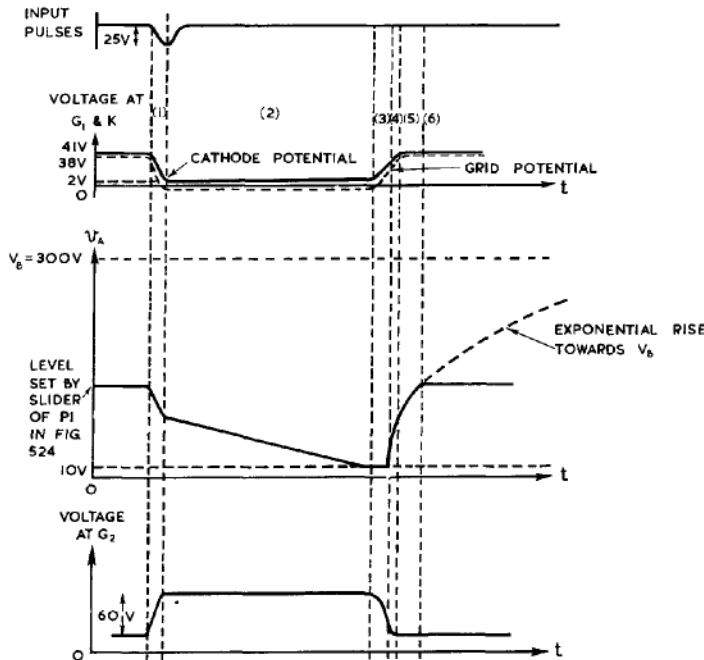

Fig. 525 - Action of phantastron circuit.

ensuring a rapid return of the anode voltage to its steady value, during intervals (4) and (5). The setting of the potentiometer P₁ determines the amplitude and hence the duration of the run-down interval (2). The rate of run-down is given by:-

$$\frac{dV_a}{dt} = -\frac{V_B}{CR} \quad (\text{This assumes that } R_3 \ll R_2, \text{ as in the case described}).$$

The other diode (valve 3) isolates the triggering circuit from the control grid after the initial fall in voltage at G₁, otherwise the run-down would be affected. The voltage at which its cathode is held (usually about 20V. above that of the suppressor grid of valve 1)

determines the initial and final values of the voltage at G_1 .

The anode voltage bottoms during the interval (3) and it is at the end of this interval that the anode current begins to fall and the second cumulative action is initiated. This action occupies interval (4), during which the screen grid, cathode and control grid return to their steady potentials.

As shown in Fig. 524, the screen grid is not fully decoupled, since this is the only electrode from which a positive-going pulse is obtained.

An alternative method of varying the duration of the output pulse is shown in Fig. 526. The setting of the potentiometer P_2 determines the rate of run-down and hence the duration of the output pulse.

The method of triggering described above requires, with the components given, a negative-going pulse of about 25 volts amplitude. Alternative triggering

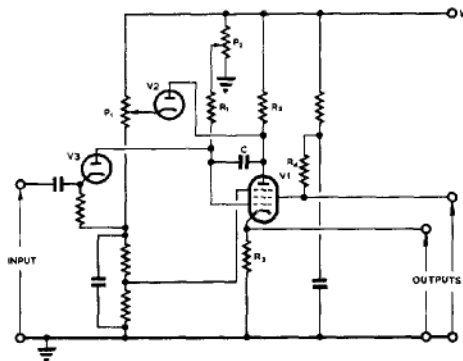

Fig. 526 - Phantastron circuit; alternative method of control.

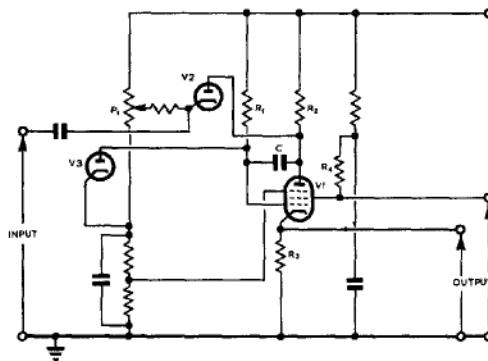

Fig. 527 - Phantastron circuit alternative triggering arrangement: negative-going pulse to μA .

arrangements are illustrated in Figs. 527 and 528. A negative-going pulse of about 40V amplitude applied to the anode (Fig. 527) or a positive-going pulse of about 25V amplitude to the suppressor grid (Fig. 528) of valve 1, is required.

The phantastron is a useful circuit in systems where the number of valves used must be kept to a minimum. It also has the advantage not possessed by the sanatron of providing both positive-going and negative-going rectangular output pulses. These can be made of approximately the same amplitude by a suitable choice of cathode and screen resistors. There are, however, several disadvantages which arise from the use of the single-valve circuit. The initial fall in voltage at the cathode (interval (1)), Fig. 526, is accompanied by a corresponding fall at the anode, so that the amplitude of the linear run-down is reduced, and a large fraction of the available supply voltage is wasted. To minimise this initial voltage

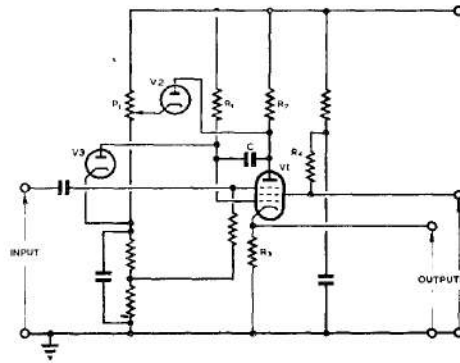

Fig. 528 - Phantastron circuit; alternative triggering arrangement: positive-going pulse.

change a valve with a very short suppressor grid base is required. Certain valves are available which have such a short base (e.g. CV1116, 3 to 15 volts), but this restricts the choice of valves so that other characteristics, which were considered in the two-valve circuit, have to be ignored.

Furthermore, the action of the phantastron is very much dependent on the choice of valves, whereas the valves used in a sanatron may be changed for others of the same type without the characteristics of the relay being appreciably affected. This is due partly to the fact that the cumulative action at the end of the linear run-down occurs over the region of control-grid cut-off in the case of the sanatron and over the region of suppressor-grid cut-off in the case of the phantastron. The latter action is not so precise as the former, and is more dependent on the particular valve used.

This file was downloaded
from the RTFM Library.

Link: www.scottbouch.com/rtfm

Please see site for usage terms,
and more aircraft documents.

