

Chapter II
TIMEBASES AND TIMEBASE GENERATORS
List of Contents

	Sect.
Introduction	
General	1
Linearity	2
Flyback	3
Time-bases derived from a source of steady voltage	4
Time-base generators for electric deflection	
Fundamental circuit of capacitive time-base generator	5
The charging circuit of a capacitive time-base generator	6
Methods of improving linearity of charging	7
Discharge circuits	8
Puckle time-base generator	9
Miller time-base generator	10
Time-base generators for magnetic deflection	11
Circular, elliptical and spiral time bases	12
Radial time base	13

CHAPTER 11

TIME BASES AND TIME-BASE GENERATORS

INTRODUCTION

1. General

If it is required to draw a graph showing the change of any quantity with time, one of the first things to do is to select a suitable time scale, and mark it along one of the axes (usually the X-axis in Cartesian Co-ordinates). A time scale is needed for the measurement of range by a radar equipment, and is normally produced by deflecting the beam of a CRT so that the spot sweeps across the fluorescent screen. A similar time scale is required if any variations of voltage or current with time are to be examined.

A multiplicity of terms has arisen in connection with the provision of a time scale. Let us now consider the meanings implied by the use of such terms in subsequent sections.

The deflection of the spot of a CRT, when it is defined in relation to time, is called a Time Base. This term should be distinguished from the term Trace, which is a general term for the pattern appearing on the screen of a CRT however produced.

The term Scan is frequently used with a variety of meanings, and is correctly used in television technique where the CRT picture is produced as a result of scrutinising a light sensitive surface point by point. In radar systems the term should be reserved for use in connection with the scanning of an area by an aerial array.

A Time-Base Generator is an apparatus for producing a voltage or current varying with time which could be used to establish a time base. A time-base generator is sometimes referred to simply as a time base, but this latter term is reserved here for the actual deflection of the spot on the screen of a CRT.

The output voltage (or current) of a time-base generator is referred to as a Time-Base Voltage (or Current). Sometimes this output is used for measuring time intervals, although it is not used to deflect a CRT beam. The output, and the apparatus producing it, are still, however, qualified by the adjective time-base. The terms Sweep Voltage and Time-Base Voltage are synonymous, but the former term is retained for the sake of the graphic idea it conveys.

In order to clarify our ideas on what is meant by a time base let us consider a specific example.

If a voltage is applied between a pair of deflector plates of a CRT the spot on the screen is deflected by an amount which is proportional to the magnitude of the voltage. Suppose a time-base generator produces a voltage which increases at a constant rate: (Fig. 529). If this voltage is applied between the X-plates of a CRT the spot moves across the screen in a horizontal direction, and a time base is formed. In this particular case, assuming uniform

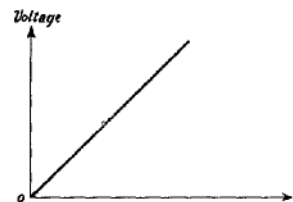

Fig. 529 - Voltage varying at a constant rate.

deflection sensitivity, the movement of the spot takes place at a uniform velocity, i.e. the spot moves through equal distances in equal time intervals.

Suppose a rectangular voltage pulse is applied between the Y plates of a CRT at a time T after the instant at which the time base starts. Then the time base is disturbed and a rectangular waveform is produced on the screen of the CRT: (Fig. 530). Then the distance between the start of the time base and the leading edge of the waveform is a measure of the time T . Similarly, the distance between the leading and trailing edges of the waveform is a measure of the duration of the applied pulse. Instead of being used to produce a deflection at right angles to the direction of the time base the rectangular voltage pulse can be employed to vary the brilliance of the spot, so that part of the time base is brighter than the remainder (Sec. 13).

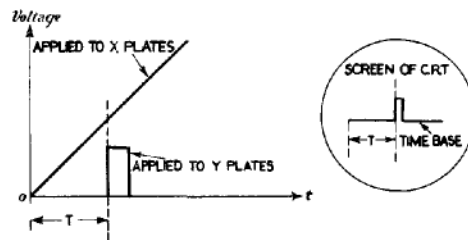

Fig 530 - Pulse applied to Y plates.

So far it has been assumed that the spot on the CRT screen makes a single sweep. Such a sweep, known as a Single-Stroke Time Base, may be used for the examination of non-repeating voltages or currents (transients). In radar, however, a time base is required which repeats itself at regular intervals. Then if the voltage to be examined is periodic and is synchronised to the time-base voltage, the resulting picture is stationary on the screen of the CRT.

2. Linearity

The time scale on a graph is generally uniform, i.e. equal lengths on the time axis correspond to equal time intervals, and it is usually desirable that the movement of the spot forming a time base should be similarly uniform. If the graph of time base voltage against time is a straight line, as in Fig. 529, the time-base voltage is said to be linear. It should be noted that even though the time-base voltage is linear, the spot-deflection or time base will not be linear unless the CRT deflection sensitivity is uniform.

In general, the term linear implies that the quantity which is measured is proportional to time, and is not restricted to straight-line time bases. For example the time base may be circular, and time intervals measured in terms of the angular deflection of the spot. Provided this angular deflection is proportional to time the time base is linear.

3. Flyback

If the time base takes the form of a repetitive sweep along a straight line the spot on the screen of the CRT must return to its starting point after each sweep so as to be ready for the succeeding one. This return movement is called the Flyback.

The flyback is an unavoidable complication; its duration occupies uselessly a portion of the period of the waveform under

examination, and it may confuse or obscure the forward sweep by superimposing its own trace. Both troubles are mitigated by making the flyback rapid, so that the ratio of sweep time to flyback is large. Under such circumstances only a small proportion of the waveform under examination is lost. Also, provided saturation of the CRT screen does not occur, the brilliance of the flyback is much less than that of the time base itself because the spot moves much more quickly during flyback than during the forward sweep.

For the examination of recurrent voltage variations in which the whole cycle is of interest a time-base voltage of the type shown in Fig. 531 is suitable; the duration of the flyback is negligible compared with that of the forward sweep.

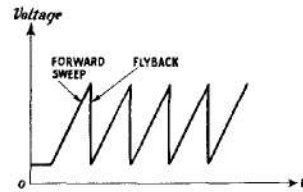

Fig. 531 - Continuous sawtooth voltage.

In radar we are often concerned with only a small fraction of the whole cycle of the time-base voltage, so that it is not essential for the flyback to occur in the shortest possible time. It is still, however, necessary to avoid confusion

between the sweep and the flyback. This is frequently achieved by reducing the voltage at the CRT grid during the flyback interval, the brilliance control being so adjusted that the forward sweep is visible and the flyback invisible. Alternatively, the grid potential may be increased during the forward sweep to give increased brightness. This "blacking-out" or "brightening" is accomplished by applying rectangular pulses of voltage at appropriate instants to the grid or cathode of the CRT (see Chap. 6). Such pulses can be readily obtained as a by-product of the time-base generator,

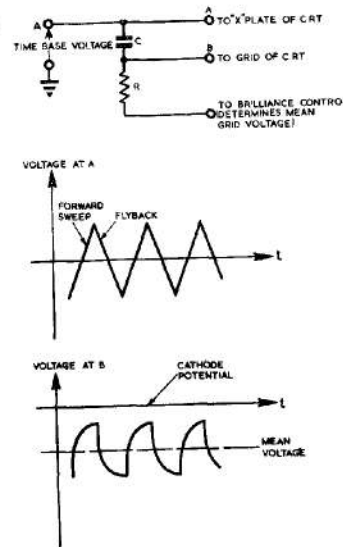

Fig. 532 - Production of pulses for brightening forward sweep and blacking out flyback.

especially if such a generator includes a relay or relaxation oscillator. Alternatively, the sweep voltage can be applied to a C-R circuit the time constant of which is short compared with the duration of the sweep voltage. In this case the voltage developed across the resistor is in the form of approximately rectangular pulses suitable for making the flyback invisible; Fig. 532. (see Chap. 2 Sec. 15).

4. Time Bases Derived from a Source of Steady Voltage

Time bases have been discussed in the previous section without reference to how they are derived. It is usual to obtain the time base voltage (usually of sawtooth form) from a source of steady voltage. Time bases derived in this way are of the straight line type, and the usual aim is to make them linear.

Time-base generators of this sort can be considered under two main headings (i) capacitive (ii) inductive. In type (i) the time-base voltage is derived from the change of voltage across a capacitance as it charges or discharges through a resistance. In type (ii) the change of current through an inductance and a resistance in series is used. Type (i) has much the wider application in radar equipments.

In both types a switching device is necessary to change the conditions of the time-base generator so that both a forward sweep and flyback are formed. The switching device may be self-operating or externally controlled. Generally, in radar equipment the switching is controlled externally so that its timing is related to other operations. In cathode-ray oscilloscopes the switching is normally self-operating, but usually arrangements are made so that the time-base voltage can be synchronised with the voltage under examination if required.

TIME-BASE GENERATORS FOR ELECTRIC DEFLECTION

5. Fundamental Circuit of Capacitive Time-Base Generator

The fundamental circuit of a capacitive time-base generator is shown in Fig. 533. The condenser C is charged through some form of charging device, and is discharged by closing the switch S. To ensure rapid action S is an electronic switch, using either "soft" or "hard" valves.

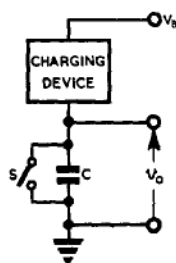

Fig. 533 - Fundamental circuit of capacitive time-base generator.

Alternatively, the condenser may be charged during the flyback period, the time-base voltage being provided by the discharge. This latter arrangement is particularly suitable for the production of very fast time bases. The necessarily small time-base resistor is then used in the discharge circuit only, and the charging resistor can be made relatively large. This arrangement reduces the likelihood of damage to the supply circuits by a break-down of the insulation across the time-base condenser.

In the circuit of Fig. 533 the condenser charges while the switch is open, and the voltage v_0 across it rises. This voltage is proportional at any instant to the charge on the condenser. If this charge increases linearly with time, i.e. if the current flowing through the charging device into the condenser is constant, v_0 increases linearly with time. In other words, if the time base derived from this generator is to be linear the charging device must pass a constant current.

When the switch is closed the condenser discharges. This discharge can be considered as instantaneous provided the resistance of the discharge circuit is small.

If the discharge circuit is of the self-operating type, the switch closes when the voltage across the condenser rises to some critical value V_S , and opens when it falls to some lower critical value V_E . The sawtooth waveform of the voltage across the condenser is shown in Fig. 534. The rate of rise of voltage can be altered by adjustment of the charging device so that the value of the charging current is

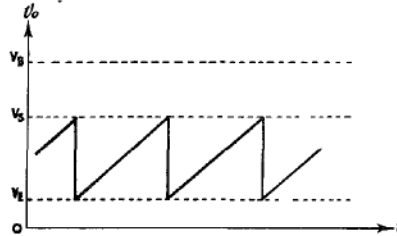

Fig. 534 - Action of circuit of fig. 533.

changed. The rate of rise of voltage determines the velocity at which the spot traces out the corresponding time base on the screen of the CRT. Hence, the control which alters the charging current is usually named the Velocity Control. Provided V_S and V_E are constant, alteration of the velocity control does not change the amplitude of the sawtooth voltage, i.e. does not change the length of the time base. It follows that the setting of this control determines the time base repetition frequency; (Fig. 535). Alteration of the voltage differences $V_S - V_E$ alters the amplitude of the sawtooth voltage, i.e. changes the length of the time base. A control which performs this function is termed the Amplitude Control. The amplitude control also alters the repetition frequency of the sawtooth voltage; (Fig. 536).

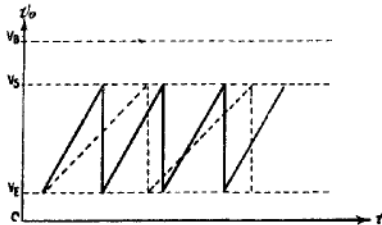

Fig. 535 - Case of alteration of velocity control changing repetition frequency.

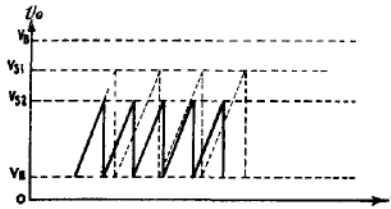

Fig. 536 - Case of alteration of amplitude control changing amplitude and repetition frequency.

If the discharge circuit is of the externally controlled type, the duration T of the rise of voltage across the condenser is fixed by the external control. Alteration of the charging current again changes the rate of rise of voltage, i.e. the velocity of the spot. Since the duration of the time base is fixed, adjustment of the velocity control is the only means of adjusting the amplitude of the time base voltage; (Fig. 537).

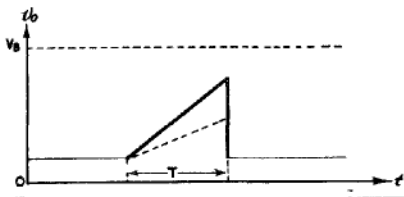

Fig. 537 - Case of alteration of velocity control changing the amplitude.

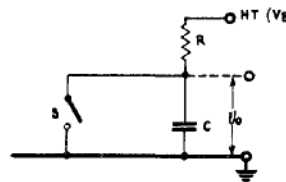

Fig. 538 - C-R charging circuit.

6. The Charging Circuit of a Capacitive Time-Base Generator

The simplest charging device is a resistor R, and if it is used the circuit of Fig. 533 becomes that shown in Fig. 538. If the switch is open, the voltage across the condenser rises exponentially towards the value V_B . Provided only a small fraction of the total rise of voltage is used to form the time base, the latter can be considered to be linear; (Fig. 539). However, a disadvantage of this method of forming a linear time base is that either V_B must be very large or else amplifiers must be used if a deflection voltage sufficient to obtain a time base of reasonable length is to be available.

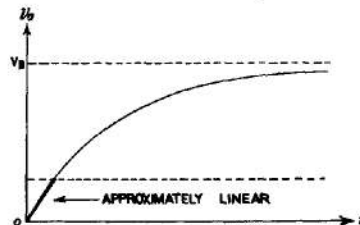

Fig. 539 - Production of approximately linear time-base voltage.

Control of velocity is obtained by adjustment of the value of the resistor, since such an adjustment alters the rate of rise of voltage, i.e. the velocity of the spot. Alternatively the capacitance of the condenser can be altered.

If the circuit is operating between fixed voltage limits, the degree of linearity is the same for all values of the time-constant. If, however, the duration is fixed the time-base voltage becomes more linear as the time-constant is increased.

7. Methods of Improving Linearity of Charging

Although the question of linearity is often mentioned in connection with time bases it is not necessarily of overmastering importance. In waveform examination, lack of time-base linearity will of course lead to a distorted picture. For example, Fig. 540 shows the waveform of a sinusoidal voltage displayed on an exponential time base. However, for ranging purposes importance of linearity depends to some extent on the method adopted for transmitting range information. Where the operator reads ranges from a scale mounted on the face of the tube, error can be avoided by making the scale correspondingly non-linear. If, however, range is measured by mechanical means (e.g. by turning a handwheel to keep a crosswire or marker in coincidence with an echo) and conveyed by a transmission system which must have a linear calibration, construction of the range measurement system is considerably simplified if the time base is made linear. Further, the time base must be linear if uniform target discrimination is to be provided at all points along the time base.

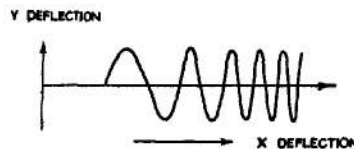

Fig. 540 - Appearance of waveform of sinusoidal voltage using exponential time-base.

When a high degree of linearity has been obtained at the time-base generator care must be taken to prevent distortion of the time-base voltage between this point and the deflector plates.

The time-base voltage is usually applied either directly or after amplification to the plates of a CRT, normally via a coupling condenser and leak resistor. The time-constant of this coupling circuit must be long compared with the duration of the time-base voltage otherwise distortion is introduced (see Chap. 2 Sec.15). In any case even if a constant-current charging device is used, the change of voltage across the time-base condenser is not absolutely linear in the presence of the coupling circuit, since the constant current flows into a network which is no longer purely capacitive.

The capacitance across the deflector plates is usually considerable, and when deflector plate current flows the conductance between the plates becomes appreciable, so that the input impedance of the deflection system is not as large as would be desirable. For this reason in order to ensure that the full time-base voltage is developed between the plates at all times the output impedance of the time-base generators must be small. This may be ensured by inserting a power amplifier, such as a cathode follower, between the time-base condenser and the deflector plates.

Various methods of improving the linearity of the time-base voltage derived from a capacitive generator are given below in paragraphs (i) to (iv). The Miller Time-Base Generator, which provides one of the most accurate methods of achieving linearity, is described separately in Sec. 10.

- (i) If only a small fraction of the total possible voltage change across the condenser is used the resulting time base is nearly linear. This method has already been discussed.
- (ii) A constant current device can be substituted for the charging resistor. Such a device is a pentode, operated above the knee of its $I_a - V_a$ characteristic.

The $I_a - V_a$ characteristics of a typical R.F. pentode, operating at a fixed screen potential for various values of grid bias, are shown in Fig. 541. From these characteristics it is apparent that if the grid bias is, say $-4V$, the anode current remains sensibly constant for anode voltages greater than about 50V. If such a valve is incorporated in the circuit of Fig. 542, when the switch is opened the condenser charges almost linearly with time until the anode voltage falls to 50V. For example, if the supply voltage is 300V, the voltage across the condenser, i.e. the time-base voltage, can have a magnitude as much as 250V without there being any appreciable departure from linearity.

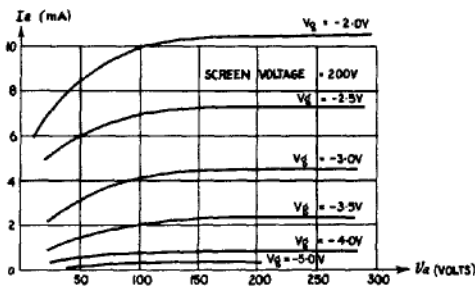

Fig. 541 - $I_a - V_a$ characteristic of typical HF pentode.

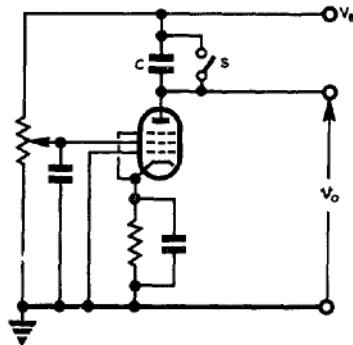

Fig. 542 - Charging circuit employing HF pentode.

The screen potential can be adjusted to provide velocity control, i.e. to change the charging current, while the grid is held at a fixed potential. In an alternative arrangement the condenser is in the cathode circuit of the valve, the time base voltage being taken from the cathode. In this case the screen must be decoupled to cathode, since variations in screen-cathode voltage would cause a change in charging current. The grid is connected to a point a few volts below cathode potential using a small cathode bias resistor.

The current through the pentode is not absolutely constant; for it to be so the slope resistance of the valve would have to be infinitely large. The greater this slope resistance the closer is the approach to linearity of the voltage across the condenser. Any method of increasing the effective value of the slope resistance leads to an improvement in linearity.

The circuit arrangements shown in Figs. 543(a) and (b) are useful in achieving this object. Fig. 543(a) shows a simple current feedback arrangement which, as described in Chap. 7, Sec. 16, increases the effective slope resistance of the valve. Fig. 543(b) shows a similar arrangement in which a second valve is used, resulting in a somewhat better current stabilisation.

(iii) If amplification of the time-base voltage is necessary, it is possible to arrange circuit conditions so that the amplifier introduces distortion which compensates for the non-linearity of the exponential time-base voltage. Exact compensation is unlikely.

For reasons given in Chap. 6 it is advisable to use balanced circuits to feed the CRT deflector plates. Fig. 544 shows how a phase-inverting amplifier employed in a paraphase circuit may be used to provide the right kind of distortion to counteract the non-linearity of the initiating time-base voltage. The amplifier valve is so biased so that it is operating on the lower bend of its dynamic characteristic.

In the circuit shown at (a), C_1 and C_2 , which together form the time-base capacitance, act also as a potential divider, so that the amplitude of the amplifier output voltage v_2 applied to the X_2 plate is equal to that of the voltage v_1 applied to the X_1 plate. The conditions are normally arranged so that when the fraction

$\frac{C_1}{C_1 + C_2}$ of the voltage v_1 (Fig. 544(b)) is fed to the amplifier,

the output v_2 is curved as shown at (c). The deflecting voltage

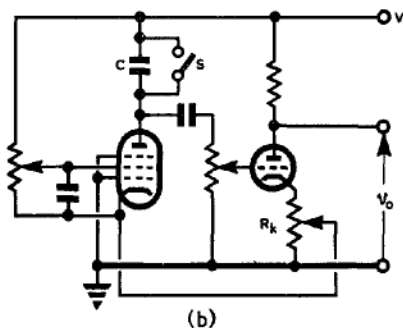
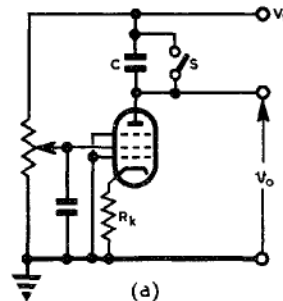

Fig. 543 - Circuits incorporating feedback to improve linearity of charging.

$(v_1 - v_2)$ is then approximately linear as shown at (d).

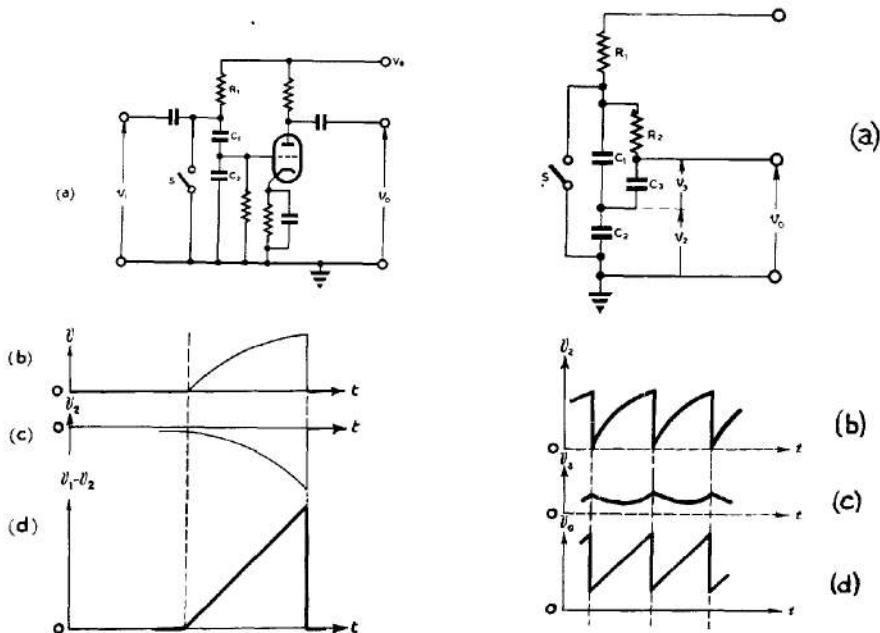

Fig. 544 - Action of circuit arrangement to counteract effect of non-linearity of time-base voltage.

Fig. 545 - Action of additional C-R to improve linearity.

The circuit described above has the advantage that no charging pentode is required. However the adjustments to the circuit are critical. If, for example, the change of condenser voltage takes place between fixed time limits (externally controlled), any alteration in the time-constant of the circuit leads to an alteration in the curvature of the fraction of the voltage v_1 which is applied to the amplifier.

(iv) The output of a simple C - R time-base circuit can be made more linear by the addition of another C - R network. One form of such an arrangement, suitable for a self-operating time-base generator, is shown in Fig. 545.

Here the charging resistance is R_1 and the main time-base capacitance consists of C_1 and C_2 in series.

Assume that the condensers, C_1 , C_2 and C_3 are charged. When the switch S is closed, C_1 and C_2 discharge rapidly. C_3 also discharges, but does so relatively slowly since the time-constant $C_3 R_2$ is long.

The switch opens when C_1 and C_2 are discharged, and at this instant the voltage across C_3 is still comparatively large. C_1 and C_2 commence to charge, but since the voltage across C_3 is greater than that across C_1 , C_3 still discharges. This discharge of C_3 continues until the voltages across C_1 and C_3 become equal, and then C_3 is charged from C_1 . The voltage rise across C_2 is approximately

exponential, whilst as we have just explained the voltage across C_3 falls at first, but after a time starts to rise.

As shown in Figs. 545(b) and (c) the curvatures of the voltage variations v_2 and v_3 are of opposite sign. Hence, if suitable values of components are chosen, the output voltage, which is the sum of these two voltages, can be made substantially linear.

8. Discharge Circuits

(i) Switching by means of Soft Valves

A gas-filled diode (neon valve) was the earliest form of switching valve used in a time-base circuit. The operation of this type of discharge valve has been described in Chap. 10 Sec. 1. Owing to the limitations set by the fixed striking voltage and extinction current neon time-base circuits are practically obsolete, giving place in the first instance to circuits using gas-filled triodes. A typical arrangement of a gas-filled triode circuit is shown in Fig. 546. If the grid bias is suitably adjusted the circuit operates as a free-running relaxation oscillator, the operation being identical with that of the neon circuit mentioned above. By variation of the grid bias the striking voltage and hence the amplitude of the time base voltage can be controlled. The action can be synchronised by the injection of a controlling voltage between grid and cathode.

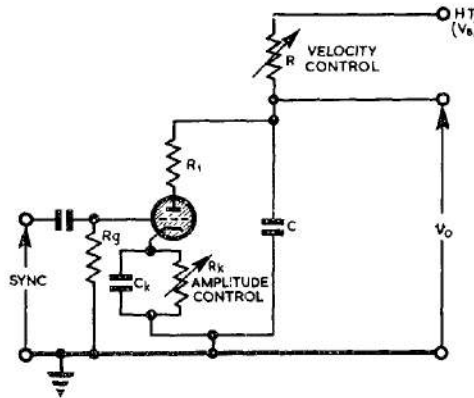

Fig. 546 - Switching by means of gas triode.

The principal advantages of using a gas-filled triode as a switching valve are the low resistance presented by the valve during the discharge, and the ease with which the circuit can be made free-running. The choice of component values, however, is limited by the uncontrollable value of the "extinction current". Ultimately the use of gas-filled discharge valves is restricted by the comparatively long de-ionisation time, of the order of a millisecond. It is not normally practicable to use soft discharge valves if the time-base frequency is more than about 40 Kc/s.

(ii) Switching by means of Hard Valves

The place of the thyatron in the discharge circuit of Fig. 546 can be taken by a hard valve, provided means are available by which the valve current can be switched rapidly on and off. With the hard valve there is no question of ionisation and de-ionisation of gas. In general, a time base generator using hard-valve switching is more definite in its operation and capable of operating

at a higher repetition frequency than one employing a soft valve.

The basic circuit in which hard-valve switching is employed is shown in Fig. 547. If the valve is conducting heavily the time-base condenser discharges rapidly, whilst if the anode current is cut off the condenser charges through a resistor. In ranging equipment the valve is usually a pentode, and switching is accomplished by alteration of the voltage at one of the grids.

By variation of the mark-to-space ratio of the input switching voltage the output voltage can be given various forms such as those illustrated in Figs. 548(a) and (b).

If the charging circuit, together with the switching valve (or valves), is incorporated in a relaxation oscillator, the circuit as a whole can be considered as a self-operating time-base generator. An example (Fleming-Williams circuit) has already been discussed in Chap. 10, Sec. 6.

In radar the pulse which operates the switching valve of Fig. 547 is normally derived from a separate relaxation oscillator or relay. Since in this case the charging or discharging of the condenser does not control the operation of the switching valve, the circuit should be considered as a time-base generator which is externally controlled. When a high voltage supply circuit is used for a time-base generator the discharge valve must be chosen to withstand the maximum voltage without appreciable leakage current. A pentode with a top-cap is normally employed. Such a valve is capable of withstanding as much as 4000 volts between anode and cathode without causing a leakage current of more than a few microamps.

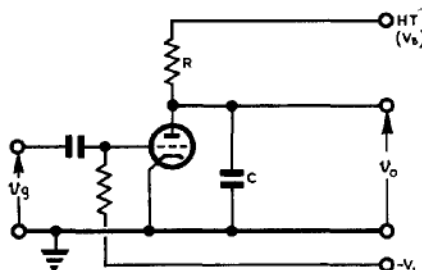

Fig. 547 - Hard valve switching circuit.

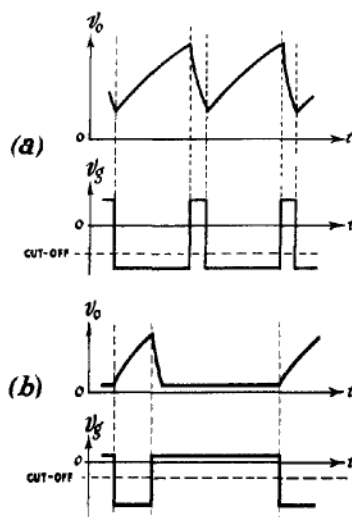

Fig. 548 - Action of hard valve circuit of fig. 547.

9. Puckle Time-Base Generator

This time-base generator, the circuit of which is shown in Fig. 549, is of the self-operating type. Valves 1 and 2 together form a relaxation oscillator. Valve 3 is a pentode, the "constant" current through which is used to charge the time-base condenser C_3 . Fig. 550 shows the relevant waveforms. An essential characteristic of this circuit is the direct connection between $1A$ and $2G$. The connections to suppressor and control grids of valve 1 are reversed in some variants of this circuit.

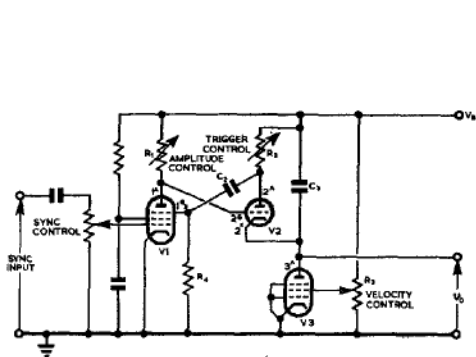

Fig. 549 - Puckle time-base generator.

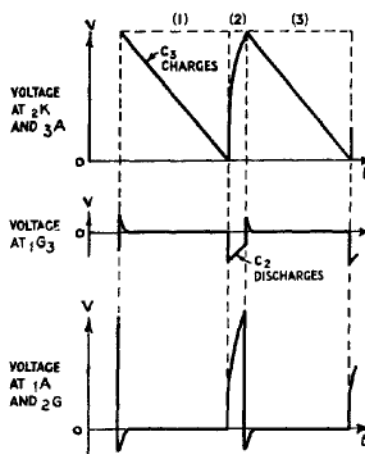

Fig. 550 - Action of Puckle time-base generator

Interval (1)

During the interval (1) C_3 charges through valve 3. Valve 2 is out off, the voltage at $2G$ ($1A$) being at a low level, since valve 1 is conducting. As the voltage at $2K$ approaches that at $2G$, valve 2 begins to conduct.

Current flows in valve 2.

The voltage at $2A$ falls.

The voltage at $1G_3$ falls.

The voltage at $1A$ rises, and with it the voltage at $2G$. This further increases the current in valve 2 so that the action is cumulative. This action ceases when the anode current of valve 1 is cut off and valve 2, is conducting heavily.

Interval (2)

C_3 discharges through valve 2 and R_2 in series, as

Chap. 11, Sect. 9

$3A$ ($2K$) rises towards V_B . C_2 discharges as $1G_3$ returns towards earth potential. A point is reached (suppressor grid cut-off) at which anode current begins to flow again in valve 1.

The voltage at $1A$ ($2G$) falls.

The current in valve 2 decreases.

The voltage at $2A$ rises and with it the voltage at $1G_3$.

The action is thus cumulative, ceasing when the current in valve 2 is cut off and valve 1 is conducting heavily.

Interval (3)

C_3 charges as the voltage at $3A$ returns towards earth potential, and the cycle repeats.

Duration of intervals.

The amplitude V of the voltage variation at $3A$ (the time-base voltage) depends on that at $2G$ ($1A$) since valve 2 acts as a cathode follower. This amplitude is therefore determined by the value of R_1 . The duration of interval (1) is the time taken for the voltage across C_3 to change by an amount V at a charging rate determined by the current through valve 3.

The flyback interval (2) depends on the rate of rise of voltage at $2G$, the time-constant being approximately R_1 times the stray capacitance between $2G$ and earth. This time-constant actually governs the rate of rise of voltage at $2G$. The rate of rise at $2K$ is further affected by the time-constant $C_3 (R_2 + R_V)$ where R_V is the resistance of valve 2 (about 2000Ω). Which ever of these time-constants is the larger effectively determines the rate of change of current in valve 2, and therefore the rate of rise of voltage at $2A$.

This rise of voltage is transferred to $1G_3$ and thus increases the rise due to the discharge of C_2 through R_4 . The duration of the interval (2) is thus dependent upon several time-constants, but usually it is $C_2 (R_2 + R_V)$ which is decisive.

The maximum repetition frequency is ultimately limited by the flyback interval (2). The upper limit in practical circuits is about 1 Mc/s.

Controls

R_1 determines the amplitude of the time-base voltage. As indicated above, it also has an appreciable effect on the duration of interval (1) and therefore the repetition frequency.

The value of the "constant" current in valve 3 is determined by the screen voltage, so that R_3 is the velocity control. R_2 determines both the time-constant $C_2 (R_2 + R_V)$ and the amplitude of the voltage variations at $2A$ and $1G_3$. It therefore controls the duration of the flyback. It is normally known as the trigger control, and may be used as a vernier adjustment to the repetition frequency.

The amplitude of the voltage used for synchronisation may be varied by means of the potentiometer marked Sync. Control. It should be noted that when the repetition frequency is fixed by the synchronis-

ing signal alteration of the velocity control varies the amplitude of the time-base voltage.

10. Miller Time-Base Generator

The principle of the Miller Time-Base generator provides one of the simplest and most effective methods of achieving time-base linearity. The basis of this principle is illustrated in Fig. 551.

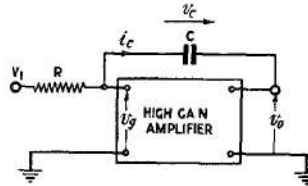

Fig. 551 - Diagram illustrating principle of Miller time-base generator.

For changes in v_o , the output voltage of the high-gain amplifier, the corresponding changes in v_g are small. If a constant voltage V_1 much greater than v_g is applied to the input, the voltage across R is approximately constant, so that to a first approximation the condenser C is connected to a constant-current source. The condenser voltage and therefore the output voltage vary almost linearly with time.

The more detailed operation of the circuit may be described as follows. If we neglect the input admittance of the amplifier, the same current i flows through R and C .

The voltage across R is:- $V_1 - v_g$

so that the current through R is

$$\frac{V_1 - v_g}{R},$$

This is the current through C , so that the variation of v_C is given by the equation:-

$$\frac{dv_C}{dt} = - \frac{i_C}{C} = - \frac{1}{CR} (V_1 - v_g).$$

But $v_C = v_o - v_g$

Hence $\frac{d}{dt} (v_o - v_g) = - \frac{1}{CR} (V_1 - v_g) \dots\dots\dots(1)$

Provided v_g is negligible compared with V_1 and the gain of the amplifier is large, so that changes in v_g are small compared with changes in v_o , equation (1) becomes approximately

$$\frac{d}{dt} (v_o) = - \frac{V_1}{CR}$$

i.e. the output voltage (the time-base voltage) varies linearly with time.

Although any high-gain amplifier will suffice to operate this circuit, the only system in common use employs a single high-gain pentode. The arrangement is shown in Fig 552(a). Normally the anode current is cut off by the suppressor grid being held at a low negative potential so that the anode potential is the same as that of the supply. When a positive-going pulse is applied to the suppressor

grid, raising the voltage there to zero, the anode voltage falls sharply as anode current flows. The grid voltage falls from zero, where it was limited by grid current, to a few volts negative. The exact extent of this initial fall is discussed in detail later. The anode voltage then commences the linear run-down as C charges through R (Fig. 552(c)). When the switching pulse is removed the anode current is cut off and the circuit reverts to its initial condition as C charges. The time-constant of the rise of anode voltage is approximately CR_e . (This neglects stray capacitance in comparison with C, and the grid-cathode resistance when grid current flows in comparison with R_e).

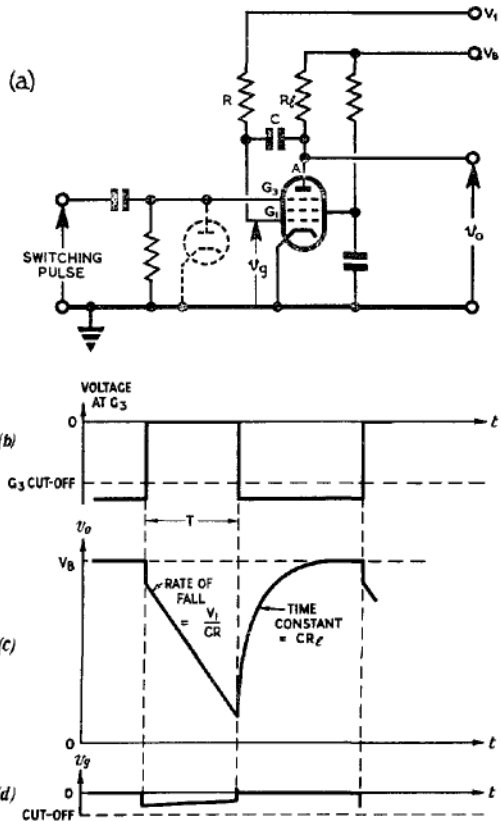

Fig. 552 - Action of Miller time-base generator.

The diode in Fig. 552(a) is a clamping diode to limit the suppressor grid voltage at earth potential.

If T is the duration of the applied pulse, the extent of the fall of the anode voltage is given by

$$T \frac{d v_o}{dt} \approx \frac{T V_1}{CR}$$

Provided this is less than V_B , the amplitude can be varied by changing R. If $\frac{TV_1}{CR} > V_B$, the anode

voltage is limited by the upper bend curvature of the dynamic characteristic. As shown in Chap. 9, Sec. 4(iv), this may occur for values of grid voltage below zero, so that subsequent changes in the voltage at the grid have little effect on that at the anode. When this occurs, as shown in Fig. 553, the time-base voltage is said to

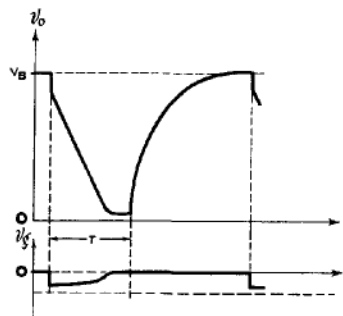

Fig. 553 - Action of Miller time-base generator when anode voltage "bottoms".

"bottom". The anode voltage remains constant so that the change in the voltage across the condenser appears as an increase in the rate of rise of grid voltage.

An alternative explanation of the Miller time-base circuit may be derived from the normal consideration of the Miller effect (see Chap. 7, Sec. 7). In the usual amplifier circuit, the input capacitance C_i of the valve is the sum of the grid-cathode capacitance C_{gk} and a feed-back capacitance $(|m| + 1) C_{ga}$, where $|m|$ is the voltage amplification, so that

$$C_i = C_{gk} + (|m| + 1) C_{ga}$$

In the Miller time-base generator the external capacitance C in parallel with C_{ga} is much greater than the interelectrode capacitances, so that the effective input capacitance is given approximately by $C_i \approx (|m| + 1) C$.

The rise in grid voltage is then similar to that of the equivalent circuit shown in Fig. 554, the time-constant being $(|m| + 1) CR$. Since the duration T of the applied voltage is of the order CR , and $|m|$ is large,

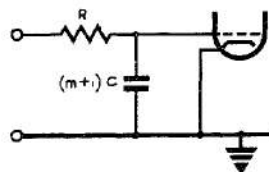

Fig. 554 - Equivalent input circuit for Miller time-base generator.

$$T \ll (|m| + 1) CR$$

so that only a small portion of the exponential voltage variation at the grid is utilised. Hence the rise in grid voltage and, consequently, the fall in anode voltage are approximately linear.

Effect of the time-base capacitance on the performance of the valve as an amplifier

So far the amplifier has been assumed to operate in a normal manner; in practice the presence of the comparatively large capacitance between anode and control grid may appreciably modify the amplifier characteristics. If the current i_c through the condenser (Fig. 555(a)) is comparable with the anode current i_a , the normal $I_a - V_a$ characteristics, superimposed on the load line, do not give the true operating conditions.

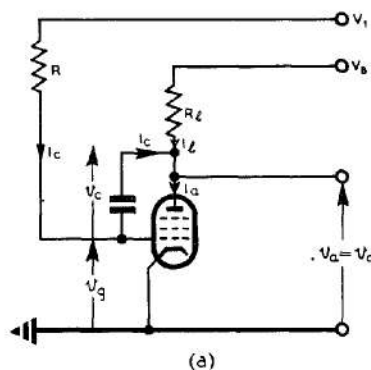

Fig. 555(b) shows how the valve characteristics can be modified to give the true conditions. For each value of v_g , the current i_c through the condenser may be determined from the relation

$$i_c = \frac{V_l - v_g}{R}$$

If this amount is subtracted from the $I_a - V_a$

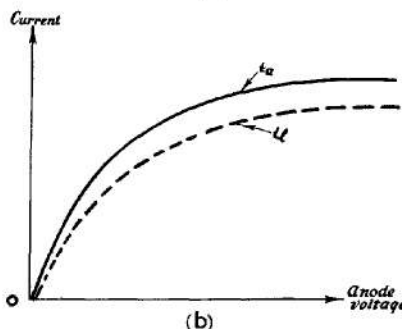

Fig. 555 - Modification to $I_a - V_a$ characteristic to give true operating conditions of Miller time-base valve.

characteristic a new curve, showing the variation of i_f with v_a , is obtained, and the intersections of the load line with a set of these curves give the true operating conditions. In most Miller time-base circuits the modification required is small since $i_C \ll i_a$, but if R is small enough to be comparable with the anode load, the condenser current is by no means negligible.

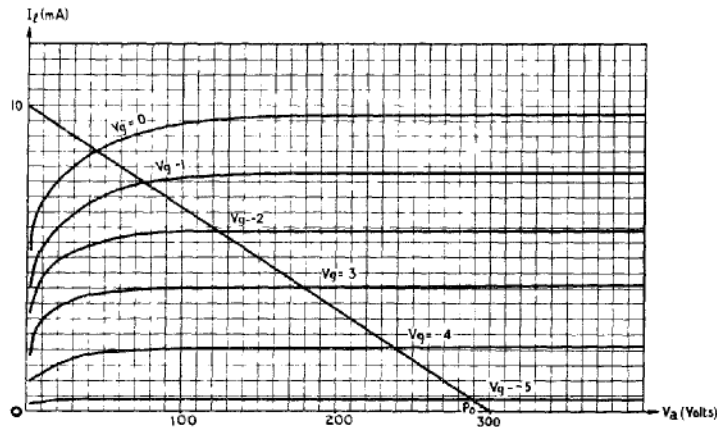

Fig. 556 - Pentode characteristics.

Fig. 556 shows a set of these modified characteristics with the load line superimposed. Initially the valve is not operating, the anode-current being cut-off by suppressor grid action, and the voltage across the condenser is approximately V_B (300V). As soon as anode current flows, the anode and grid voltages fall so that the working point P_0 is reached where $v_a - v_g = v_C = 300V$. In the case illustrated this occurs for $v_a = 295V$ and $v_g = -5V$. The anode run-down then follows the load line until terminated either by the anode voltage bottoming (due to grid current) or by the return of the suppressor grid to its cut-off value.

For any working point P , the values of v_g and v_a may be obtained from the load line.

Hence $v_C = v_a - v_g$ may be obtained.

$$\text{Since } \frac{dv_C}{dt} = -\frac{i_C}{C} = -\frac{V_1 - V_g}{CR}, \quad \frac{dt}{dv_C} = -\frac{CR}{V_1 - v_g},$$

so that $\frac{dt}{dv_C}$ may be plotted against v_C . The area enclosed by this graph gives the time t . It is thus possible to obtain the values of v_C , and therefore of v_a and v_g , for each instant t .

An analysis of this nature reveals that for a pentode with an amplification factor of the order of 100, departure of the anode voltage from linearity is normally less than 1%, and, by a suitable choice of components, can be made considerably less.

It may be shown that the ideal shape for the dynamic characteristic is the logarithmic form shown in Fig. 557. For a given pentode the anode load, charging resistor R , and input voltage V_1 may be chosen so that the dynamic characteristic has the optimum shape. Under these

circumstances the departure from linearity may be reduced to as little as 0.01%. Such accuracy is not, however, independent of the valve used, and if an interchange of valves is necessitated the accuracy is reduced to about one part in a thousand.

If very slow time bases are required a large capacitance C must be used. If this is greater than a few microfarads the leakage resistance will be appreciable and the linearity of the output voltage will be affected. (This is not likely to arise in time-base circuits, but is important where the Miller principle is utilised in an integrating circuit using a time-constant of several seconds, such as might be required in a mechanical control system (see Chap. 18, Sec. 21).

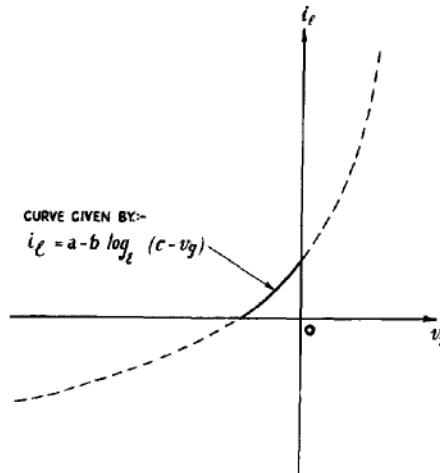

Fig. 557 - Ideal shape of dynamic characteristic.

11. Time-base Generators for Magnetic Deflection

The deflection of the spot of a CRT can be produced by changing the current in a deflector coil. If a linear time base is required, the current through the coil must rise linearly with time.

The fundamental circuit consists of a coil and resistor in series. (The coil may be the deflector coil itself, or may be inductively coupled to the deflector coil. The resistance may consist wholly or partly of the resistance of the coil).

Consider the effect of a steady voltage instantaneously applied to such a circuit. The current in the circuit grows according to the equation

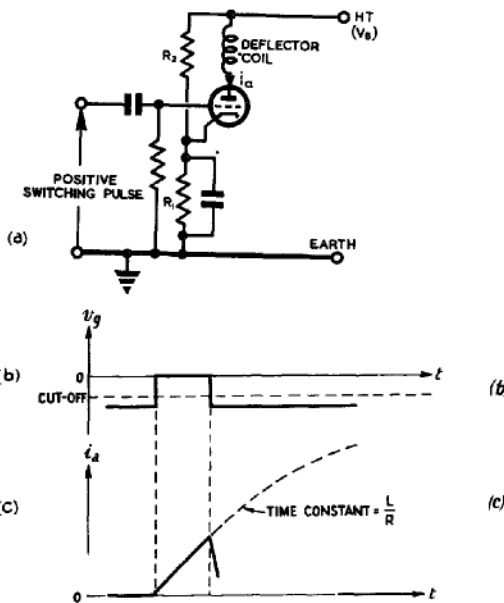

Fig. 558 - Simple time-base generator for magnetic deflection. Application of rectangular voltage pulse.

$$i = \frac{V}{R} \left(1 - e^{-\frac{Rt}{L}} \right),$$

where V is the magnitude of the applied voltage (see Chap. 2, Sec. 6). Provided only a small fraction of the total change of current is utilised the resulting time base is approximately linear (compare Sec. 6).

Fig. 558 shows the circuit of a simple time-base generator. Here the time constant $\frac{L}{R}$ of the circuit (where R is the total resistance i.e. the sum of the valve resistance and the resistance of the coil) is likely to be long compared with the time during which the valve is allowed to conduct. The valve current is normally cut off by the biasing arrangement which in this case consists of resistors R_1 and R_2 . A positive-going rectangular pulse (b), applied to the grid, renders the valve conducting for the duration of the time base, and the current through the coil increases exponentially.

Consider the effect of applying a linear rise of voltage to a circuit containing L and R in series. If the rate of rise of applied voltage is m , then the current at any instant is given by :-

$$mt = L \frac{di}{dt} + iR \quad (\text{see Chap. 2, Sec. 13}).$$

The solution of this equation is :-

$$i = \frac{mt}{R} + \frac{mL}{R^2} \left(1 - e^{-\frac{Rt}{L}} \right),$$

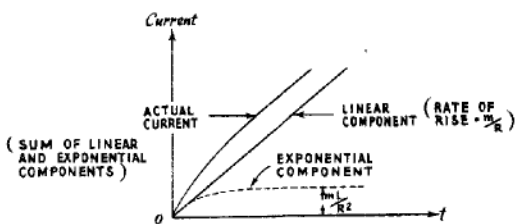

Fig. 559 - Effect of applying a linear rise of voltage to a series L - R circuit.

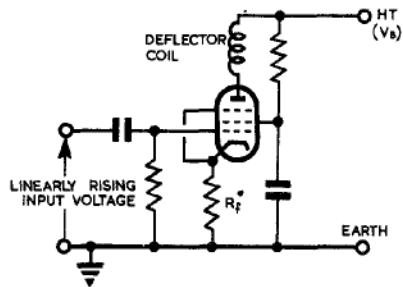

Fig. 560 - Simple time-base generator for magnetic deflection. Application of a linear rise of voltage.

i.e. the current consists of two components one of which varies linearly with time and the other exponentially (Fig. 559). If the time constant of the exponential rise is small in comparison with the duration of the applied voltage, the exponential component quickly rises to its maximum value; subsequently the rise of current is linear. For a given value of L the time constant $\frac{L}{R}$ is made smaller by increasing the value of R . However, such an increase in R reduces the linear rate of rise of current, and therefore decreases the total rise of current taking place in a given time interval.

A suitable circuit arrangement is shown in Fig. 560. The deflector coil is shown in the anode circuit of a pentode. A linear rise of voltage, developed by one of the circuit arrangements described

Chap. 11, Sect. 11

in Sec. 7, is applied to the grid of the pentode, which is biased so that it operates over the linear portion of its characteristic. The total resistance in series with the inductance is the sum of the resistance of the coil and the effective slope resistance of the valve. The effective slope resistance of the valve is increased, and therefore the time-constant $\frac{L}{R}$ is decreased, by the provision of negative current feedback, which is due to the presence of the un-bypassed resistor R_f in the cathode circuit.

In the two arrangements considered so far it is clear that the change of current through the deflector coil is not linear, and can be made approximately so only by the sacrifice of a considerable portion of the possible current change. A more economical method of obtaining a linear change of current is illustrated in Fig. 561.

The current variation is shown at (a). The manner in which the current decreases during interval (1) is usually unimportant, since this interval corresponds to the flyback. It is usually important, however, that the current should increase from zero or some other specified value at the beginning of interval (2). During the interval (2) the current is given by

$$i = at ; \quad (b)$$

The corresponding voltage across the resistor is

$$Ri = atR.$$

The voltage across the coil is

$$L \frac{di}{dt} = aL ; \quad (c)$$

Hence the total voltage across coil and resistor is $aL + atR$. It follows that the applied voltage during the growth of current is required to be of the form

$$V + mt,$$

where

$$\frac{V}{m} = \frac{L}{R}.$$

Since the manner in which the current returns to zero is unimportant, the shape of the negative-going portions of the applied voltage is usually immaterial.

A voltage variation of the form shown in Fig. 561 (d) is commonly produced by circuits of the relaxation oscillator or relay type. Alternatively, the circuit of Fig. 562(a) can be used. This circuit is essentially a time-base generator of the type described in Sec. 6, but is modified by the inclusion of a resistor R in series with the time-base condenser C . A negative pulse is applied to the grid of the valve so that the valve current is out off. The rise of voltage across the resistor R is given approximately by:-

$$V = \frac{R}{R_e + R} \cdot V_B.$$

The voltage across the condenser C cannot change instantaneously so that the output voltage of the circuit at instant (1) rises by the same amount.

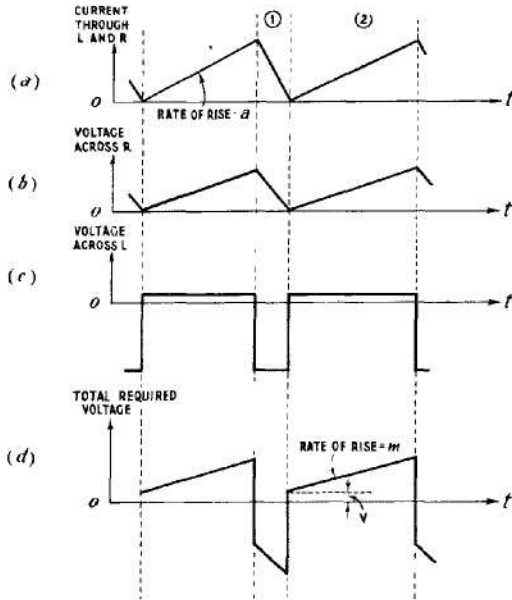

Fig. 561 - Synthesis of voltage required to be applied to a series L-R circuit to obtain a linear rise of current.

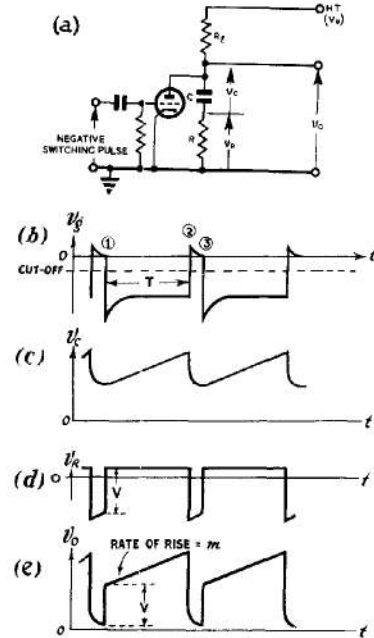

Fig. 562 - Action of time-base circuit which provides an output voltage suitable for producing a linear rise in current if applied to a series L-R circuit.

During the time interval (1) to (2) the condenser charges exponentially with a time constant $C(R_e + R)$. Provided $C(R_e + R) \gg T$, the rise of voltage across the condenser is nearly linear, and the current flowing through R is almost constant. Consequently the output voltage varies as shown at (e).

At instant (2) the valve conducts. Provided R_e is large compared with the resistance of the valve when conducting v_o falls almost to zero. During the interval (2) to (3) C discharges through R and the valve in series.

If the amplitude of the instantaneous rise of output voltage at instant (1) is V and the rate of the linear rise is m the values of V and m depend on the values of R_e and R. It can be shown that variation of R alters the ratio V/m .

It follows from the discussion of the waveforms of Fig. 561 that, if the output voltage of the circuit of Fig. 562(a) is applied to a series L-R circuit to generate a linear time-base current, R must be adjusted so as to make

$$\frac{V}{m} = \frac{L}{R}$$

A suitable circuit arrangement for producing a

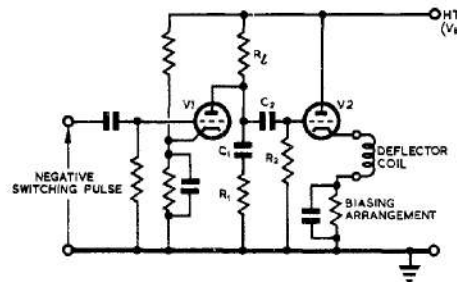

Fig. 563 - Circuit for producing linear increase of current in deflector coil.

linear increase of current in a deflector coil is shown in Fig. 563; this arrangement incorporates the circuit of Fig. 562. Valve 2 can be biased so that little if any current flows through the coil, except during the appearance of the time base, so that the deflection of the spot starts from the centre of the screen. Such an arrangement is advantageous if a radial time base (Sec. 15) is required. In this circuit the effective resistance of the L-R circuit includes the anode-cathode resistance of the valve 2 and the resistance of the coil.

Provided the time-constant C_2R_2 is large compared with $C_1(R_e + R_1)$, little distortion is introduced by the coupling circuit so that the output of the cathode follower applied to the L-R network is an accurate reproduction of the voltage across C_1 and R_1 .

When a valve circuit is used for the generation of time base currents for magnetic deflection it is usually necessary to produce the fly-back by cutting off the current of the time-base valve, which has the deflector coil in its anode or cathode circuit. This causes the coil to ring with its self-capacitance and strays, and unless precautions are taken this ringing may have deleterious effects. The anode voltage may be raised to such a high value as to damage the valve, or to render it conducting again. Further, the oscillations may be prolonged so that they interfere with the succeeding time-base sweep (Fig. 564). The oscillations may be damped out by the inclusion of a series or parallel damping resistor of suitable value.

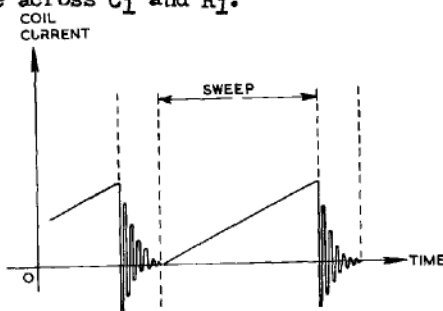

Fig. 564 - "Ringing" in deflector coil.

Such a resistor may affect the manner in which the current through the coil changes during the time-base sweep. It may be replaced by a diode and resistor together in parallel with the deflector coil (Fig. 565). When the current through the valve is increasing, i.e. when the time-base is being formed, the voltage across the coil holds the anode voltage of valve 1 below HT. Consequently, the diode does not conduct since the voltage at its anode is negative with respect to that at the cathode. When the valve current is suddenly cut off the anode voltage of this valve, and therefore the anode voltage of the diode, rises above that of the HT supply. The diode conducts and the energy of the electromagnetic field of the coil is dissipated in the resistor.

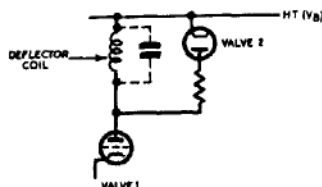

Fig. 565 - Damping circuit.

12. CIRCULAR, ELLIPTICAL AND SPIRAL TIME BASES

One form of time-base generator is an oscillator or other source of sinusoidal oscillations. If a sinusoidal voltage is applied between a pair of deflector plates of a CRT a straight line time base is produced. A similar result is obtained if a sinusoidal current passes through a pair of CRT deflector coils. Under such circumstances, the CRT spot moves to and fro with a simple harmonic motion, and the displacement of the spot from its rest position at any instant is proportional to $\hat{v} \sin \omega t$ (where \hat{v} is the peak value of the deflecting voltage and angular frequency $\omega = 2\pi f$). If a sinusoidal voltage (or

current) of large amplitude is used, the effective time-base voltage is practically linear (Fig. 566); however, the spot remains on the screen for only a small fraction of the period of the sinusoidal voltage and the time base is useful only if the waveform to be examined is of comparatively short duration. The fly-back may need blacking out since it traverses the screen at the same rate as the forward sweep.

A time base in the form of an ellipse or circle is formed on the screen of a CRT if one sinusoidal voltage is applied between one pair of deflector plates, and another sinusoidal voltage of the same frequency in quadrature with the former is applied to the other pair. This assumes that the deflection sensitivity for each pair of plates is uniform in the region of the trace. If the deflections produced by the two voltages are equal in amplitude the time base is circular in form, otherwise it is

elliptical. As the frequencies of the two sinusoidal voltages must be the same these voltages are usually derived from the same source, the phase difference being introduced by means of a condenser-resistor arrangement; (Fig. 567). In the case of the circular time base the spot moves at a constant speed (i.e. the time base is linear) and the trace is useful for the whole of its period.

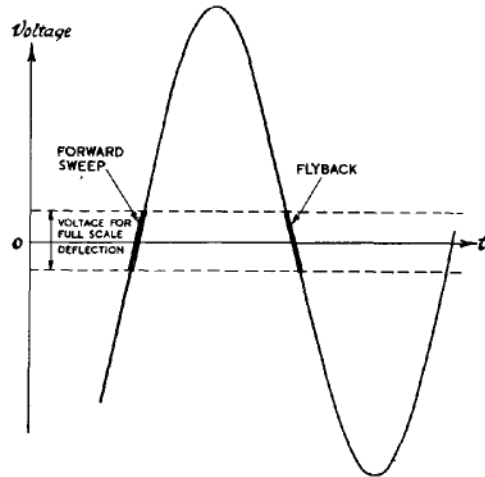

Fig. 566 - Sinusoidal time-base voltage.

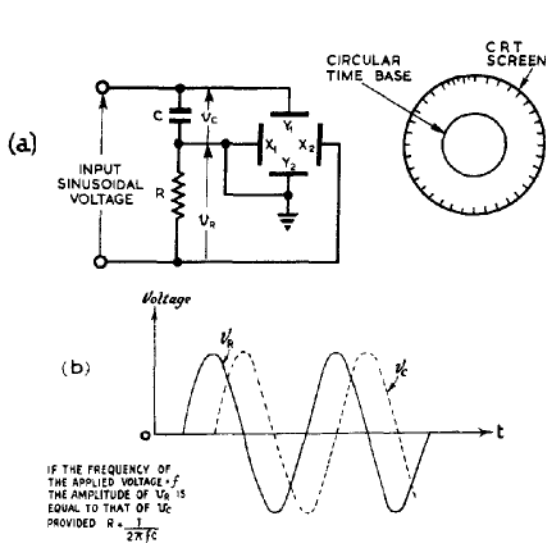

Fig. 567 - Production of a circular time-base. Electric deflection.

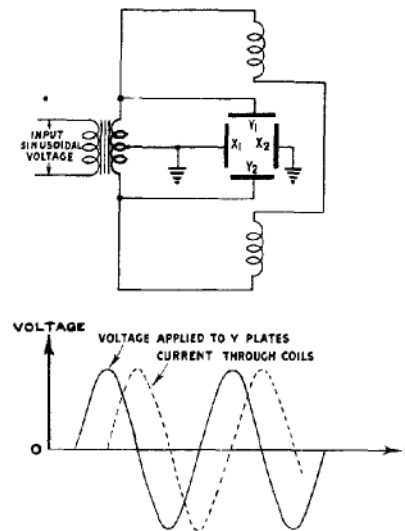

Fig. 568 - Production of a circular time-base. Mixed deflection.

An elliptical or circular time base may also be produced using electric and magnetic deflection. Consider the arrangement of Fig. 568; the vertical magnetic field gives the horizontal deflection while the electric field of the Y-plates gives the vertical deflection. The current through the deflector coils is in quadrature with the supply voltage, and therefore with the voltage applied to the Y-plates, so that no extra phasing circuit is required. The X-plates are available for other purposes.

In the circuits which have been described for producing circular time bases the effect of stray capacitance has been ignored; in practice the input capacitance of deflector plates and the self capacitance of deflector coils are appreciable and modifications to the circuits are necessary. For a CRT of given screen diameter a circular time base provides a trace of greater length than is possible with one of straight line form. Therefore, if the time base is of a given duration, the circular shape gives the greater visual discrimination between signals separated by small intervals of time.



Fig. 569 - Spiral time-base.

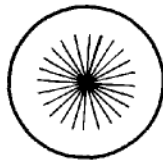

Fig. 570 - Radial time-base.



Fig. 571 - PPI display.

If the time-base voltages applied to the CRT are not truly sinusoidal, but decrease in amplitude from one cycle to the next, the time base takes a spiral shape; (Fig. 569). Such a shape allows for a still greater extension of the length of the time base. A damped ringing circuit is suitable for generating this kind of time base. Alternatively, a sinusoidal voltage may be applied to an amplifier, to which is fed a sawtooth modulating voltage, thereby producing a time-base voltage of the required form. Suppose that the ratio of the frequency of the sinusoidal voltage to that of the sawtooth generator is r . If r is an integer, a stationary time base is formed. If r is not exactly an integer the time base will appear to rotate.

If $\frac{1}{r}$ is a large integer a radial time base is formed which looks like the spokes of a wheel (Fig. 570).

13. RADIAL TIME BASE

If a time base of straight line form is arranged to start from the centre of the screen of a CRT, and is then made to rotate about this point at a rate which is slow compared with the repetition rate of the time base, a number of successive radii are traced on the screen; (Fig. 570). The resulting trace is termed a Radial Time Base. This type of time base has wide applications in radar, forming the basis of the Plan Position Indicator (PPI) display. The electron beam of the CRT is

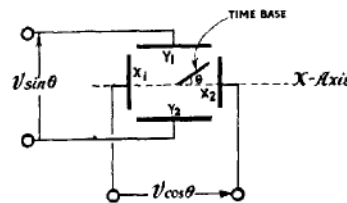

Fig. 572 - Arrangement used in electrical method of producing a radial time base.

normally modulated by signal voltages, so that the presence of signals is indicated by a brightening of a portion of the trace (Chap. 6, Sec. 31). The brilliance of the trace as a whole is adjusted so that only those portions are visible which have been brightened by signal voltages. Provided the screen of the CRT is of the after-glow type, bright patches indicating the presence of target echos can be visible at different parts of the screen simultaneously; (Fig. 571). One method of producing such a time base, which however is not normally used in radar, has already been indicated at the end of Sec. 12.

The number of spokes formed on the screen of the CRT is given by the ratio:-

$$\frac{\text{Period of Rotation}}{\text{Repetition Period of time base}}$$

and if this is of the order of a 1000, the screen is likely to have almost every part of its surface covered by the trace during each period of rotation.

There are two main methods used to produce a radial time base. The first method, which is sometimes used if the time base is developed by magnetic deflection, is to rotate mechanically the deflector coils about the axis of the CRT. Such an arrangement works well for low speeds of rotation but at high speeds mechanical problems become difficult, and it is preferable to employ a system which avoids the use of moving parts at the CRT. In any case, if the time base is developed by electric deflection, mechanical rotation of the deflector plates is not easily obtained.

The basis of the electrical method of producing a radial time-base is as follows. Two similar sawtooth voltages are produced, one of which has an amplitude $V \sin \theta$ and the other an amplitude $V \cos \theta$. If these two voltages are applied to the Y- and X-deflection systems of a CRT respectively, the straight-line time base produced makes an angle θ with the X-axis, (Fig. 572). As θ is made to vary, the time base rotates.

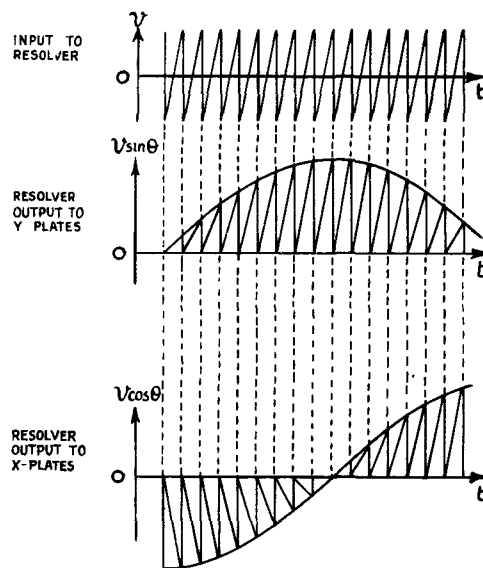

Fig. 573 - Resolver voltages.

The voltages necessary for producing a radial time base are normally derived from a voltage of recurrent sawtooth waveform and of constant amplitude. Such a voltage is applied to a resolver which may take any one of the forms described in Chap. 3. The resolver provides two output voltages each similar to the input but with amplitudes proportional to $\sin \theta$ and $\cos \theta$ respectively where θ is the mechanical setting of the resolver (Fig. 573).

This Page Intentionally Blank

This file was downloaded
from the RTFM Library.

Link: www.scottbouch.com/rtfm

Please see site for usage terms,
and more aircraft documents.

