

Chapter 18
RANGE MEASUREMENT
List of Contents

	Sect.
Introduction	
Timing systems	1
Sawtooth timebases	2
Sinusoidal timebases	3
Range corrections	4
Calibration	5
Principles of signal selection	6
Sawtooth circuit	7
Sinusoidal circuits	8
Range markers	9
Sawtooth timebase circuits for accurate range measurement	
General requirements	10
Linear condenser	11
Linear resistance	12
Exponential rheostat method	13
Exponential potential method	14
"Decade" potentiometer-rheostat method	15
Earthing the potentiometer slider	16
Coarse and fine timebases	
General principles	17
Sawtooth timebase with marker	18
Flat spiral timebase	19
Fine J-scope timebase	20
Timebase with expanded portion	21

CHAPTER 18

RANGE MEASUREMENT

INTRODUCTION

1. Timing systems

The fundamental problem is to measure the time interval between the transmission of a radio-frequency pulse and the reception of the required echo. At the same time it is desirable to separate the echoes from different targets so that the measurement of ranges to them may be made independently or even concurrently. This may be done by an operator using a display unit, or by an automatic device; in the latter case it is usual for the automatic ranging unit to be associated with an auxiliary display, enabling the operator to choose which of several targets shall be followed, and to override the automatic unit if it locks on to an unwanted signal, such as a jamming signal, fixed echo or friendly "target".

If R yards is the slant range from the set to the target, and c (327.72 million yards per second) is the velocity of propagation of electromagnetic waves in air, then the time delay t_e microseconds between transmission and reception of the pulse is given by the equation

$$t_e = \frac{2R}{c}$$

i. e. ,

$$R = \frac{ct_e}{2}$$

$$= 163.86 t_e$$

Since pulses are transmitted at more or less regular intervals, the Range R measured by the timing device varies as shown in Fig. 844.

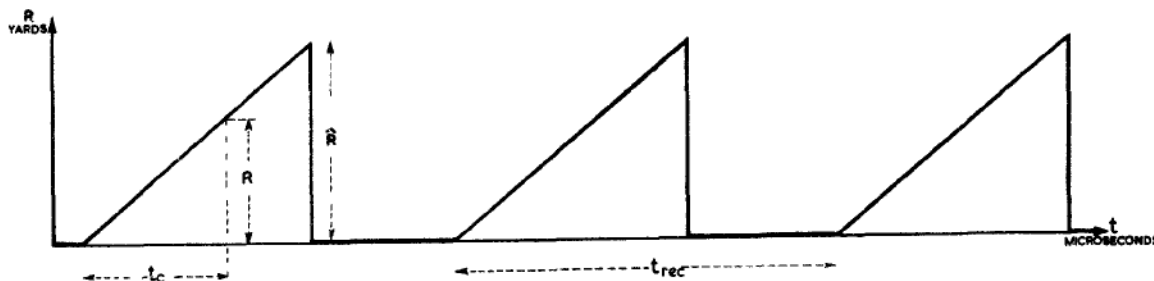

Fig.844 - Range/time chart.

Because of the short intervals involved and the necessity for accuracy, an electronic device must be used. For accuracy of 25 yards it is necessary to measure time-intervals correct to one-seventh of a microsecond.

The time-standard used is therefore a recurring potential or current waveform, produced by an electronic "clock", and will be called a "timebase" whether or not it is used to produce a trace on a CRT.

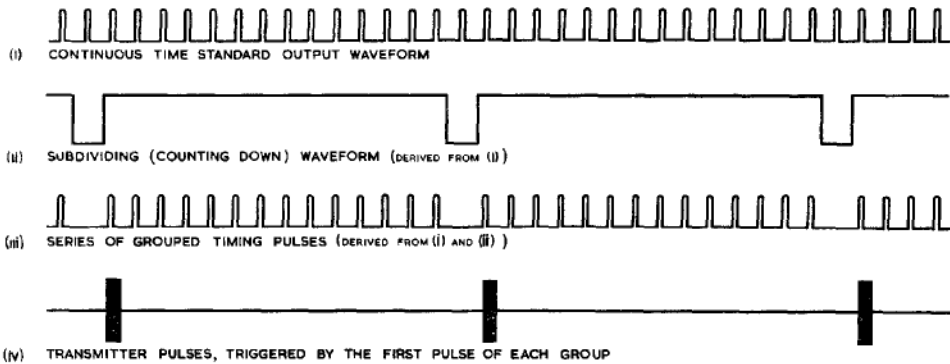

Fig. 845 - Continuous timebase pulses

Two fundamental types of "clock" are used; continuous, (or free-running) and discontinuous, (or triggered). In the first case, the timing mechanism produces a succession of uniformly spaced impulses, and to make the system of measurement recurrent, the firing of the transmitter must be synchronized with the "clock", or timebase (Fig. 845). With the second type, the transmitter is impulsed by a separate device, which also triggers the time base; the latter stops before the next transmitter pulse starts and the process is repeated (Fig. 846).

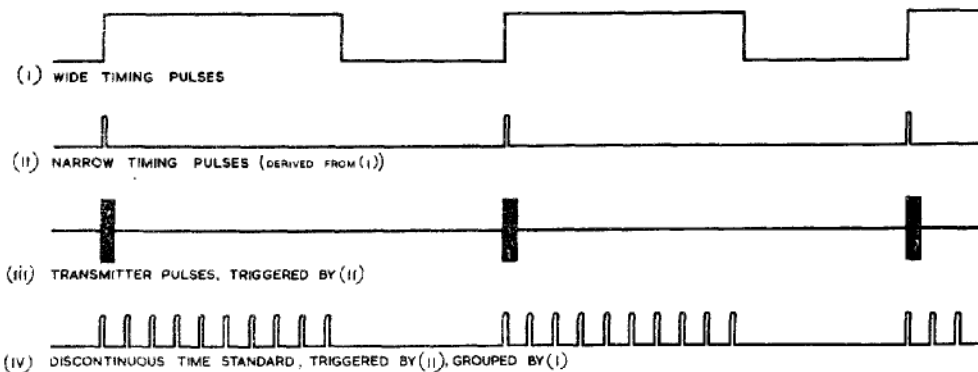

Fig. 846 - Discontinuous timebase

A further subdivision of timing systems separates them into primary and secondary standards. A primary time-standard does not vary with use or age beyond the limits necessary to provide the accuracy required of the equipment. A secondary time-standard is not sufficiently accurate in itself, and requires calibration by a primary standard, which may be part of a built-in calibrator, or is a piece of external test equipment.

A crystal calibrator is the primary standard normally used in radar, while secondary standards may take the form of high Q oscillatory circuits, exponential or linear timebases or multivibrators.

A primary time-standard may be discontinuous but is usually continuous, in which case it cannot be used to calibrate a discontinuous secondary standard; in this event the device which normally controls the transmitter must be disconnected, and for it must be substituted a locking circuit triggered by the primary standard, as shown in Fig. 847.

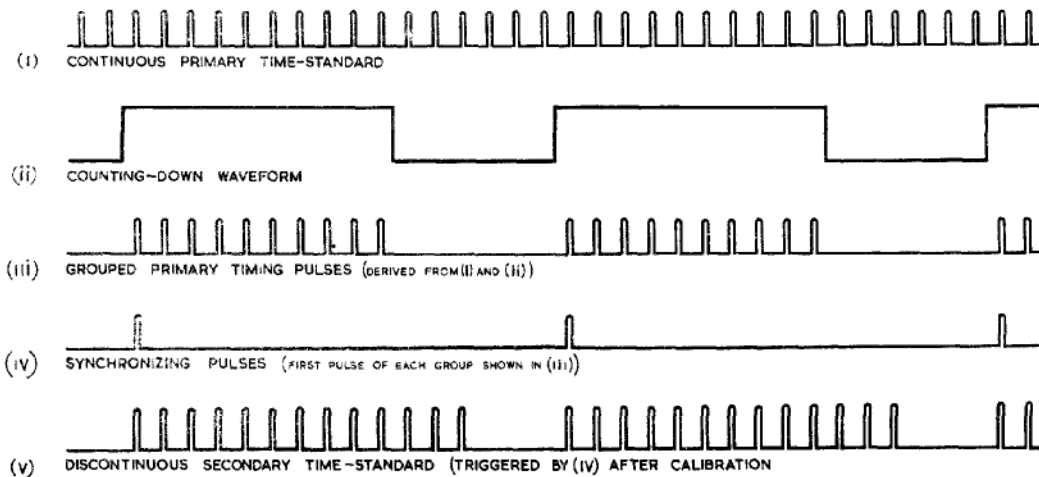

Fig. 847 - Synchronized discontinuous timebase

In all cases the primary standard produces only a series of calibrated points on a Range scale. One of two methods may be used to interpolate between these points.

In the first method the received echo is displayed on a CRT using a timebase following a known law. The external scale is made to correspond to the calibrated points while the intermediate graduations are interpolated. For a fixed timebase the scale may be attached permanently to the face of the CRT. Alternatively the echo may be aligned with a crosswire, either by moving the crosswire to coincide with the echo or vice versa; in either case a dial attached to the handwheel producing the movement may be graduated by interpolation between the calibrations. The characteristic of the method is the dependence for accuracy on the timebase conforming to a known law between the calibration points.

The second method consists of moving the calibrated points until one of them coincides with the echo. This is done by a delay network or phase-shifting device; the movement of a handwheel produces a time delay or phase

shift from 0-360° proportional to rotation and is provided with a linear range calibration. This method is the more accurate and is readily adaptable to coarse and fine range indicators, since the same interpolating phase-shift or delay is required between any pair of calibrated points.

The use of a delay network is applicable to both sawtooth and sinusoidal timebase circuits. In an elementary form it consists of a decade arrangement of low-pass filter sections, successive sections being inserted in cascade until the total time delay due to the network is sufficient to bring the locking pulse into coincidence with the echo under investigation. In such a form it is inaccurate and suffers from the inevitable "jumpiness" of the decade arrangement.

Other forms of delay circuits, including electrical liquid-column delay cells and acoustical delay tanks are usable and have the advantage of continuous, instead of step-by-step, adjustment.

It is also possible to use a variable delay network in place of a phase shifting device for interpolation between successive calibration points. As such it is inferior to the circuits described in Sect. 3 because it is discontinuous, jumping from maximum to zero delay at each calibrated point, and because of the difficulty of adjustment.

The principal timebases used are (i) linear, (ii) exponential and (iii) sinusoidal, in increasing order of accuracy. Current timebases may be used, but the following laws are given for potential waveforms only; in each case V_0 is the supply voltage.

(i) Linear timebase; $V_e = \frac{V_0 t_e}{T}$, where

T is an arbitrary constant.

Timebases which are approximately linear are used for coarse range measurement or for interpolation on a large scale timebase.

(ii) An Exponential timebase; $V_e = V_0 (1 - e^{-t_e/T})$

where T is the time constant

Exponential timebases formed by C-R rather than L-R circuits may be made very accurately, the chief difficulty being the avoidance of leakage across the condenser.

(iii) Sinusoidal timebase; $V_e = V_0 \sin(\omega t_e + \phi)$

where ϕ radians is an arbitrary phase angle and $f = \frac{\omega}{2\pi}$ is the

frequency. If $f = \frac{163.86}{n}$ Kc/s, one cycle corresponds to n thousand yards of the timebase.

A damped sine wave may be used with the law $V_e = V_0 e^{-Kt_e} \sin(\omega t_e + \phi)$, but provided K is small and measurements are made from, or near, the zero of this wave form the inaccuracies involved in neglecting the variations in amplitude are negligible.

For accurate range measurement, the marker or crosswire must be aligned with a definite portion of the echo. If the leading edge of the echo is used, errors due to varying pulse width are eliminated, but only at the expense of S/N ratio, since a wider band amplifier is required accurately to reproduce the sharpness of the leading edge of the received pulse. The method most economical in this respect is to bisect the echo pulse with the crosswire

dividing it into portions of equal area, but although suited to automatic range measurement this is not easy by visual methods. A wide marker may be used, and the echo maintained in the centre of it. (Fig. 848(a)).

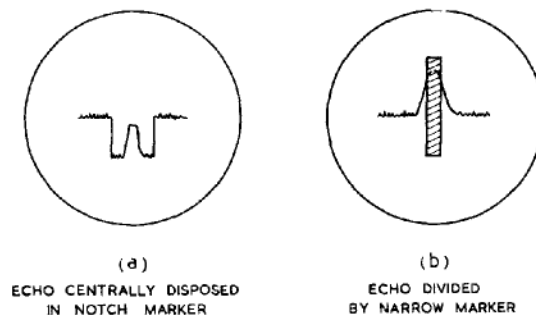

Fig. 848 - Presentation of marker pulses

Finally, a narrow marker may be kept in such a position that it divides the echo into two peaks of equal height; this naturally results in some loss of peak amplitude, but permits of considerable distortion of the square pulse-shape and corresponding increases of S/N ratio (Fig. 848(b)).

The problem of range measurement, signal selection and provision of range markers are essentially the same; they all involve the selection of a particular portion of the timebase. The first measures the range to this point, the second produces a coarse "strobing" pulse and the third an accurately positioned marker pip. It will frequently be necessary, to avoid redundancy, to deal with one of these as a particular case, or combination, of the others.

2. Sawtooth timebases

The simplest method of range measurement involves synchronising a CRT sawtooth timebase with the transmitted pulse and causing the echo to deflect the spot at right-angles to the range trace. This is the A-scope presentation (Fig. 849). The whole timebase sweep is viewed simultaneously, and range may be estimated from a range scale attached to the face of the tube, as shown.

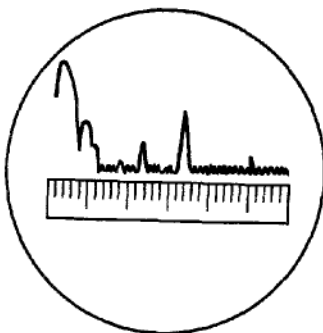

Fig. 849 - A-scope presentation

The chief disadvantage of this method is the inherent inaccuracy due to the smallness of the scale. Besides this, many of the common CRT distortions are liable to produce range errors. Variations in supply voltage and in components, and changes in deflection sensitivity with different settings of the control circuits are all liable to produce inconsistencies and irregularities in range measurement. In particular deflector plate current is the source of an extremely variable error depending on the setting of the brightness control.

In place of the external scale a movable marker may be used. The forms which this may take are dealt with in Sect. 9. The circuit producing the marker must be provided with a handwheel or other mechanical control which drives an indicator graduated in range. The accuracy of range measurement thereby depends on the correspondence between the graduations on this scale and the corresponding range at which the marker is produced on the timebase (Fig. 850).

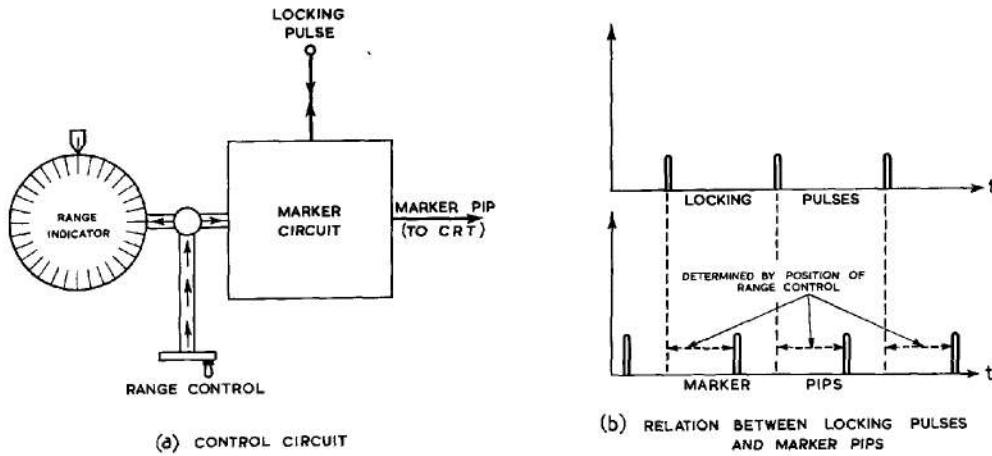

Fig. 850 - Use of marker pulses

The first of two fundamental sawtooth marker-producing circuits is shown in Fig. 851. The movement of the slider is calibrated in range, so that $V_s = f_s (R)$.

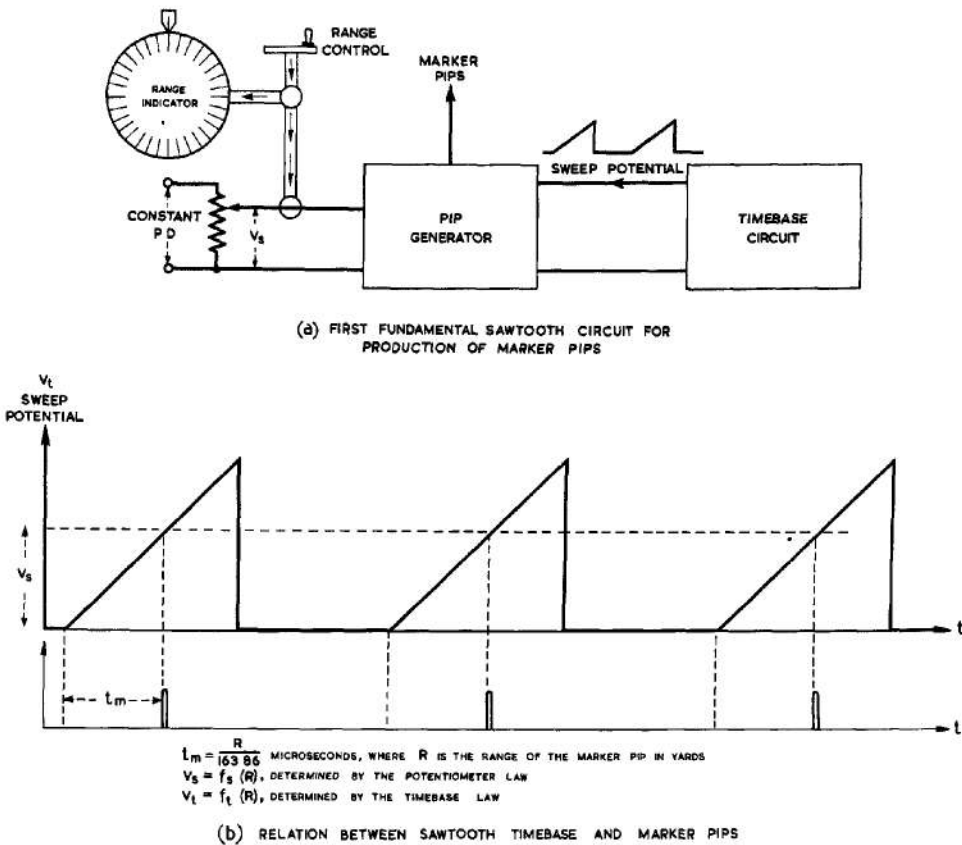
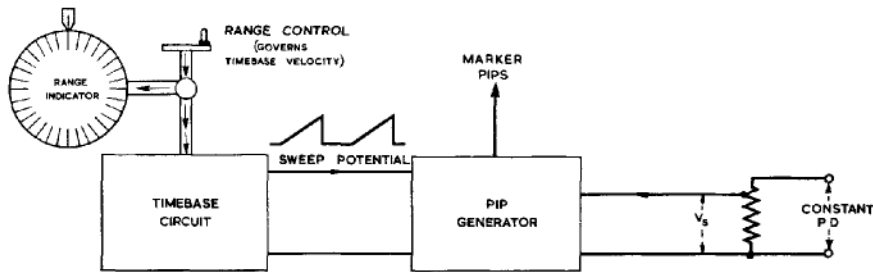

Fig. 851 - Constant gradient timebase marker

The timebase voltage is a function of time and thus of range, so that $V_t = f_t (R)$.

As the timebase voltage reaches V_s , the selector valve is triggered and the marker is produced on the timebase. For correct calibration of the slider position, $f_s (R) = f_t (R)$, and on this correspondence the range accuracy depends.

There is no need to use the same timebase for the marker circuit as for the CRT, and the separation of the two circuits allows greater flexibility in the design of the marker circuit.



(a) SECOND FUNDAMENTAL SAWTOOTH CIRCUIT FOR PRODUCTION OF MARKER PIPS

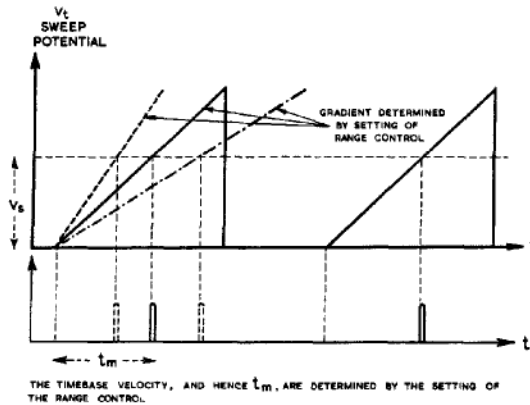

THE TIMEBASE VELOCITY, AND HENCE t_m , ARE DETERMINED BY THE SETTING OF THE RANGE CONTROL.

(b) RELATION BETWEEN SAWTOOTH TIMEBASE AND MARKER PIPS

Fig.852 - Variable gradient timebase marker

Fig.852 shows the schematic design of the second fundamental marker producing circuit. Here V_s is constant and the timebase itself is varied so that the instant t_m at which the timebase potential reaches V_s is governed by the velocity control. Since $t_m = \frac{R_m}{163.86}$ microseconds this control may be calibrated in R_m , the range at which the marker appears.

Where range output data is to be transmitted automatically, it is most desirable to ensure that the calibration of the range indicator is linear, so that coarse and fine indicators may be used. Unless the range control itself is linear this involves some form of cam between the range control

and range indicator; since the latter is not usually practicable, the range control is designed so that, whatever the timebase law, equal movements of the control generate equal increments of the marker range.

In the circuit of Fig.851 this may be accomplished by making the timebase a linear one; the range potentiometer is then also a linear one, with equal resistances for each stop between equally spaced studs. For the method of Fig.852 a linear velocity control is required.

For more exact measurement the exponential timebase of Fig.853 may be used.

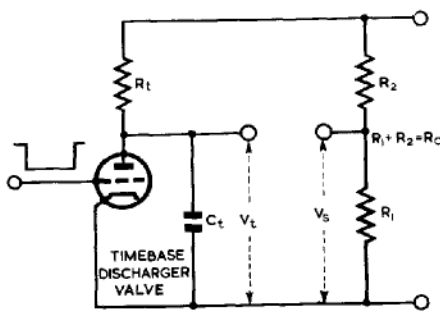

Here
 $R_m = 163.86 C_t R_t (\log R_0 - \log R_2)$
 referred to as the range equation

$$V_t = V_0 (1 - e^{-t_m/C_t R_t}),$$

while

$$V_s = V_0 \cdot \frac{R_1}{R_0} = V_0 (1 - \frac{R_2}{R_0});$$

hence, where the marker appears, and
 $V_t = V_s,$

$$e^{-t_m/C_t R_t} = \frac{R_2}{R_0};$$

i.e., $t_m = C_t R_t \log (R_0/R_2)$

Since $R_m = 163.86 t_m,$ we have

$$R_m = 163.86 C_t R_t (\log R_0 - \log R_2).$$

Fig.853 - Exponential timebase

This result, which is independent of the supply voltage $V_0,$ suggests four methods of range measurement.

- (i) Varying C_t (linear condenser method).

This is an example of the "constant potential circuit" of Fig.852. V_s is constant and R_m is proportional to $C_t.$

- (ii) Varying R_t (linear resistance method).

This is similar to (i), with R_m proportional to $R_t.$

- (iii) Varying $R_0,$ but not R_2 (exponential rheostat method).

This is an example of the "fixed timebase" method of Fig.851. R_m is a logarithmic function of $R_0,$ which thus requires to be exponentially calibrated.

- (iv) Varying R_2 but not R_0 (exponential potentiometer method). This is similar to (iii), with R_2 exponentially calibrated for range.

Details of the circuits using the above methods are given in Sect.3.

Instead of being used to produce a marker, the signal selector circuit may shift the timebase relative to the CRT. In this case the echo is aligned with a fixed external crosswire. The additional error involved is the possible movement of the electrical centre of the CRT and this is usually negligible.

3. Sinusoidal timebases

Range determination using a sinusoidal timebase consists of the measurement of the phase shift between one of the zeros of the sinewave and the position of the echo (Fig.854). This phase shift may be measured on the CRT or produced by a mechanical movement calibrated in range. In the first case the sinusoidal potential waveform can be used to produce a circular trace. When this is properly set up, the angular displacement from

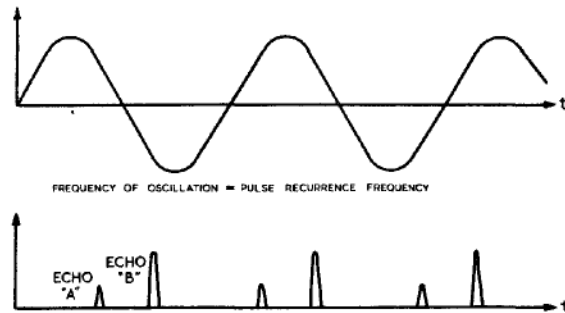

Fig. 854 - Sinusoidal timebase

the zero position of the radius to the echo determines the phase shift directly (Fig. 855(a)). The schematic circuit arrangements are shown in Fig. 855(b). The echo is produced as a radial displacement by a special

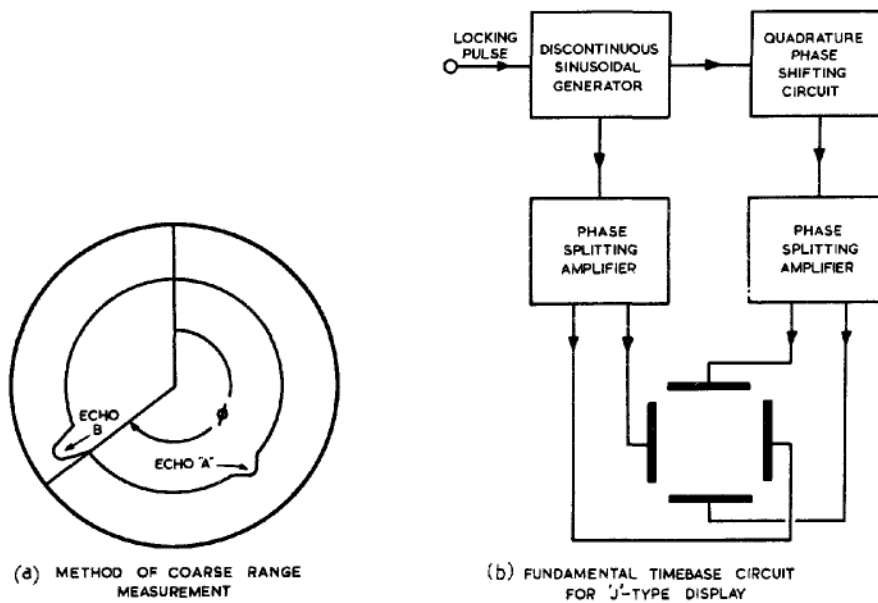

Fig. 855 - Circular timebase

centrally disposed deflector electrode either outside or inside the tube. In this elementary circuit, the pulse recurrence frequency is also the timebase frequency.

The principle may be extended to the use of a spiral timebase, originated by a "damped sinewave" of the form

$$V = V_0 e^{-kt} \sin(\omega t + \phi),$$

such as may be generated by a ringing circuit triggered by the locking pulse. The natural frequency $f = \frac{\omega}{2\pi}$ of this circuit may be many times greater than the recurrence frequency of the transmitted pulse and the scale of the timebase correspondingly increased.

Chap 18, Sect. 3

Fig. 856 shows the schematic arrangements of an all-electric and an all-magnetic deflection system for producing a timebase in the form of an equiangular spiral. Provided the 'x' and 'y' deflection systems are



EACH TURN OF THE SPIRAL REPRESENTS n YARDS, THE FREQUENCY f OF THE RINGING CIRCUIT BEING ADJUSTED SO THAT

$$f = \frac{153.86}{n} \text{ Mc/s}$$

(a) METHOD OF RANGE MEASUREMENT

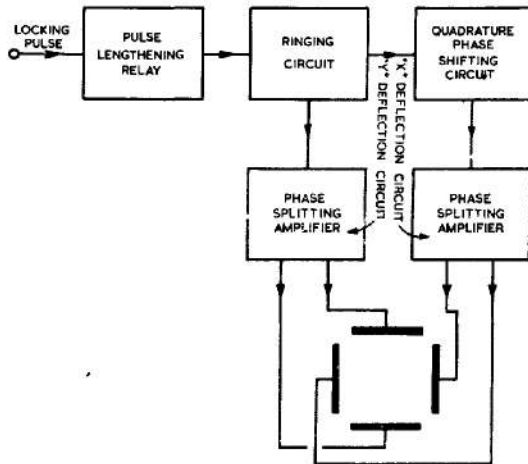

(b) CIRCUIT EMPLOYING RINGING CIRCUIT AND ELECTRIC DEFLECTION

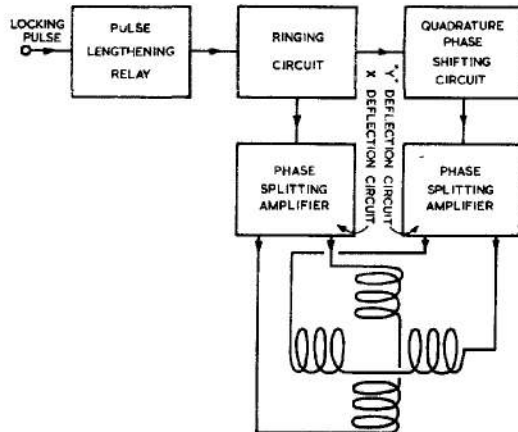

(c) CIRCUIT EMPLOYING RINGING CIRCUIT AND MAGNETIC DEFLECTION

Fig. 856 - Spiral timebase

perpendicular, and ignoring nonlinearity in the circuit elements and deflection sensitivities, the electron beam rotates with uniform angular velocity, while the distance from the spot to the screen centre decreases exponentially as shown below.

Let x cm be the x-deflection and 'a' its maximum value;
 Let y cm be the y-deflection and 'b' its maximum value;
 Let $f = \frac{\omega}{2\pi}$ be the natural frequency of the ringing circuit;
 Let ϕ be the initial phase,
 θ the angular rotation,
 r the radius and
 k the logarithmic decrement.

$$\begin{aligned} \text{Then } x &= r \cos \theta = a e^{-kt} \cos(\omega t + \phi) \\ y &= r \sin \theta = b e^{-kt} \sin(\omega t + \phi) \end{aligned}$$

$$\therefore \tan \theta = \frac{b}{a} \tan(\omega t + \phi)$$

When correct adjustments are made to ensure that $a = b$, then it follows that $\theta = \omega t + \phi$ and $r = a e^{-kt}$ with the result that the trace is an equiangular spiral.

If $f = \frac{163.86}{n}$ Mc/s, one turn of the spiral corresponds to n yards.

Hence, if the echo appears on the m th turn, at an angular displacement of θ radians from the zero position, the range to the echo is

$$mn - \frac{n\theta}{2\pi} \text{ yards}$$

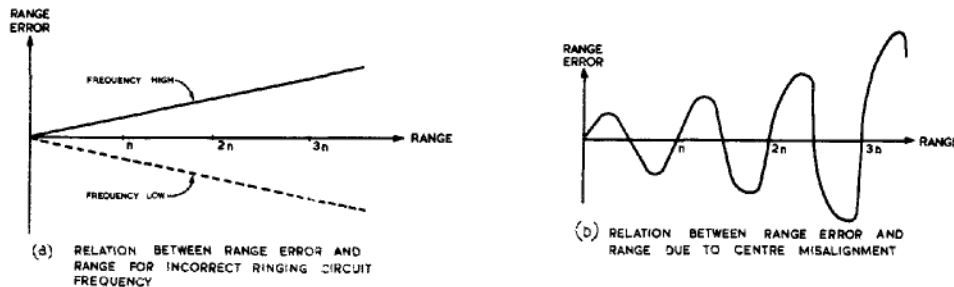

Fig.857 - Inaccuracies in spiral timebases

The inaccuracies which arise in these circuits are due to the following causes.-

CRT irregularities:- irregular (non-cylindrical) deflection sensitivity, due to trapezium distortion, deflector plate current, etc; non-perpendicularity of x and y deflecting systems.

Frequency variations:- these introduce an error proportional to range (Fig.857(a)).

Incorrect centring:- if the centre of the scale or cursor is not the electrical centre of the CRT. (Fig.857(b)).

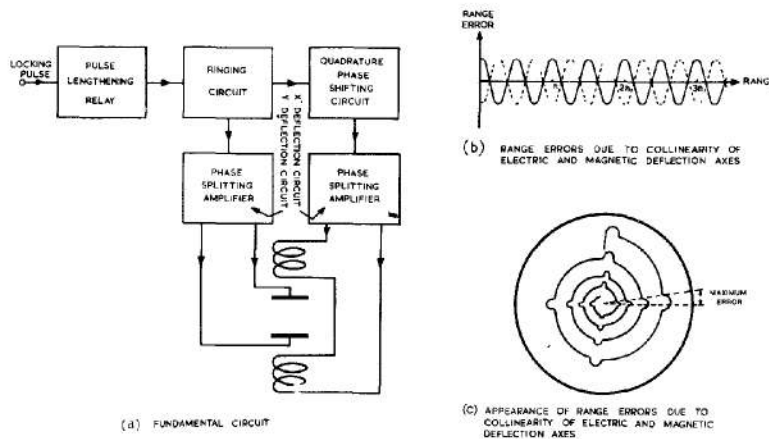

Fig.858 - Electric-magnetic spiral timebase

A circuit using combined electric and magnetic deflection is shown on Fig.858(a). If the magnetic and electric deflection axes are truly collinear, an error arises which destroys the linearity of the range calibration (Fig.858(b)). To correct this the deflector coils are usually rotated slightly until the non-linearity is removed.

$$v = Ri + L \frac{di}{dt} \quad \text{where } \left. \begin{array}{l} R = \text{total resistance} \\ L = \text{total inductance} \end{array} \right\} \text{ of the coils.}$$

$$\text{If } i = a e^{-kt} \cos(\omega t + \phi)$$

$$v = \omega L a e^{-kt} \sin(\omega t + \phi) - KLa e^{-kt} \cos(\omega t + \phi) + Ra e^{-kt} \cos(\omega t + \phi),$$

and unless $R = KL$, i and v are not in quadrature; hence if x is proportional to i and y to v , as would happen were the coils and deflector plate axes collinear, the spiral would be elliptically distorted. The distortion is illustrated in Fig.858(c), where four calibrator pips, at equal time-interval spacings, are shown for each turn of the spiral.

If the deflector coils are rotated through an angle α , the x deflection is reduced by a factor $\cos \alpha$, while to the y deflection is added an additional term proportional to $i \sin \alpha$,

$$\text{i.e. proportional to } e^{-kt} \sin \alpha \cos(\omega t + \phi);$$

by a suitable choice of α the three terms involving $\cos(\omega t + \phi)$ are eliminated.

Another method of eliminating the unwanted in-phase term of v is to make $R = KL$: this is done by using a parallel damping resistor so that the parallel and series damping coefficients are equal.

There are three types of device which are used for the continuous mechanical measurement of phase shift, the goniometer, the capacity phase-shifter and the potentiometer phase-shifting network, shown in Fig.859. The original sinewave is first delayed by a 90 deg. phase shift; from the original and the delayed waveforms, two waveforms are obtained in quadrature and of equal amplitude. The correct fractions of these waveforms are added or subtracted to produce the desired phase shift.

$$\text{If } V_1 = a \cos \omega t \quad V_2 = a \sin \omega t;$$

$$V_0 = V_1 \cos \beta - V_2 \sin \beta = a \cos(\omega t + \beta), \text{ where}$$

β is the required phase shift.

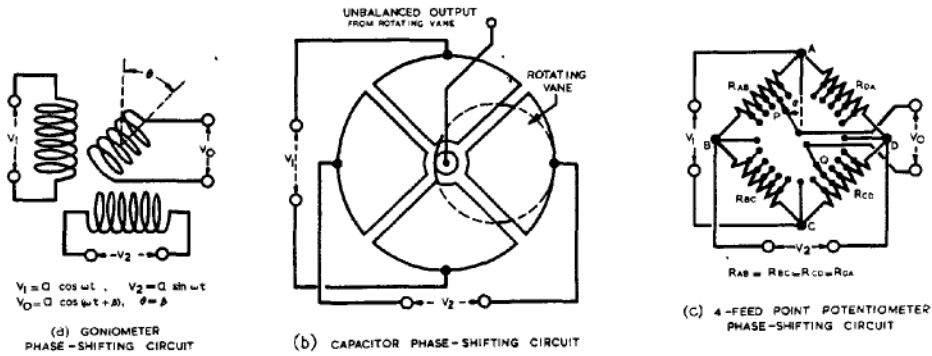

Fig. 859 - Phase-shift circuits

The goniometer arrangement, when properly adjusted, provides that θ , the angular rotation of the rotor, is equal to β , the phase shift, and may be calibrated in range from 0 to n yards where

$$f = \frac{163.86}{n} \text{ Mc/s (Fig. 859(a)).}$$

The capacity phase shifter is the electric analogue of the magnetic circuit of the goniometer and produces the same effect.

In both these devices, the accuracy of the correspondence between rotation and phase shift depends on the tolerances of manufacture.

For the potentiometer phase-shifting network, the vector diagram of Fig. 860 shows the amplitude and phase of the waveform tapped off by the sliders P and Q, relative to the input waveforms V_1 and V_2 .

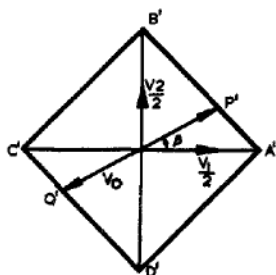

THE PRIMED LETTERS INDICATE THE POTENTIALS AT THE CORRESPONDING POINTS ON FIG 859 (c)

In order that β , the phase shift is to be the same as the angular rotation θ , of the potentiometer slider, R_{pb} must be the same function of θ as it is of β . Since the magnitude of R_{pb} is proportional to $P'B'$, this relation is clearly not linear. Exactly,

$$R_{pb} = \frac{R_{ab}}{2} \left[1 + \tan \left(\frac{\pi}{4} - \beta \right) \right]$$

Provided R_{pb} is made equal to

$$\frac{R_{ab}}{2} \left[1 + \tan \left(\frac{\pi}{4} - \theta \right) \right],$$

then θ is an accurate measure of β .

If R_{pb} is made linear, i.e.,

$$R_{pb} = \frac{2}{\pi} R_{ab} \left(\frac{\pi}{2} - \theta \right)$$

Fig. 860 - Vector diagram for potentiometer phase shifter
an error in range equal to

$\frac{n(\theta - \beta)}{2\pi}$ is introduced, and this error is plotted against θ in Fig. 861, assuming the use of a large number of studs.

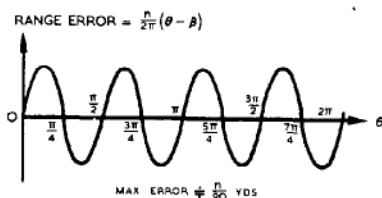

Fig. 861 - Error/rotation curve

In Fig. 862(a) a compromise is shown between accepting the errors of the linear resistance network and making the relatively costly network conform to the exact law. The corresponding vector diagram is shown in Fig. 862(b) and the errors in Fig. 862(c). As the former shows, the amplitude of the output waveform is practically independent of β .

In any of these phase-shifting circuits, errors will be introduced, if the two fundamental waves are not truly in quadrature. These errors will be of the double-frequency type similar to those illustrated in Fig. 858(b).

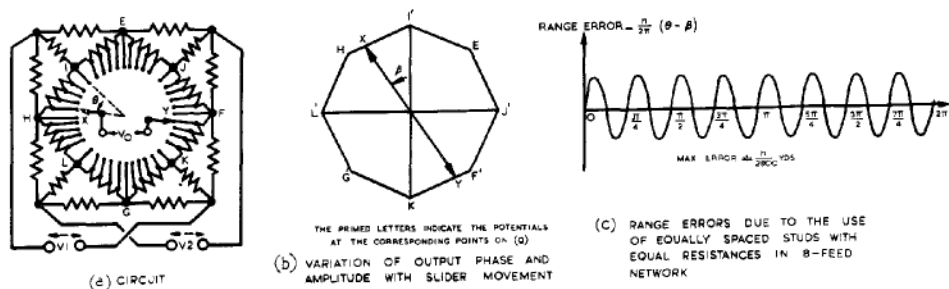

Fig. 862 - Compromise resistance phase-shift circuit

The phase shift produced by one of the above methods enables a zero of the initiating sinewave to be aligned with the echo. As the waveform passes through zero a selector valve is opened and a marker pip produced, as described in Sec. 6. The alignment of this marker with the echo by the use of the phase-shifting control measures the range to the echo.

This method has little advantage, if any, over the sawtooth method if the frequency of the sinewave is the recurrence frequency. A great improvement in accuracy results if the frequency is much higher, due to the stability of the tuned circuit or crystal. In such a case, since a marker is produced every time the waveform rises through zero, one of these must be selected by a coarse range-measuring device, such as a sawtooth marker-producing circuit.

Two alternative schematic circuits are shown in Figs. 863 and 864. In the second circuit, the initiating sinewave generator, which may be a primary time standard, acts as a master timing circuit, controlling both the range marker system and the pulse recurrence frequency. These circuits are the basis of coarse and fine range measurement. The phase-shifting (fine range) and signal selector (coarse range) controls must be ganged so that the movement of a single handwheel drives the range indicator and both selecting circuits. The coarse control must be sufficiently accurate to ensure that the correct fine range marker is always gated.

Instead of being used to produce a marker, the phase-shifting circuit may rotate the timebase relative to the CRT. In this case the echo is aligned with a fixed external crosswire. The additional error involved, as in the case of its sawtooth analogue, is the possible movement of the electrical centre of the CRT and thus is usually negligible.

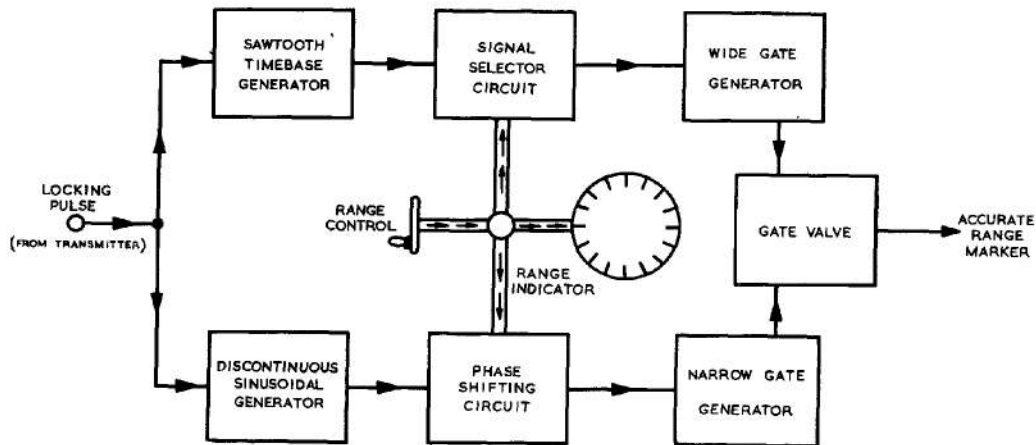

Fig.863 - Range marker locked from transmitter

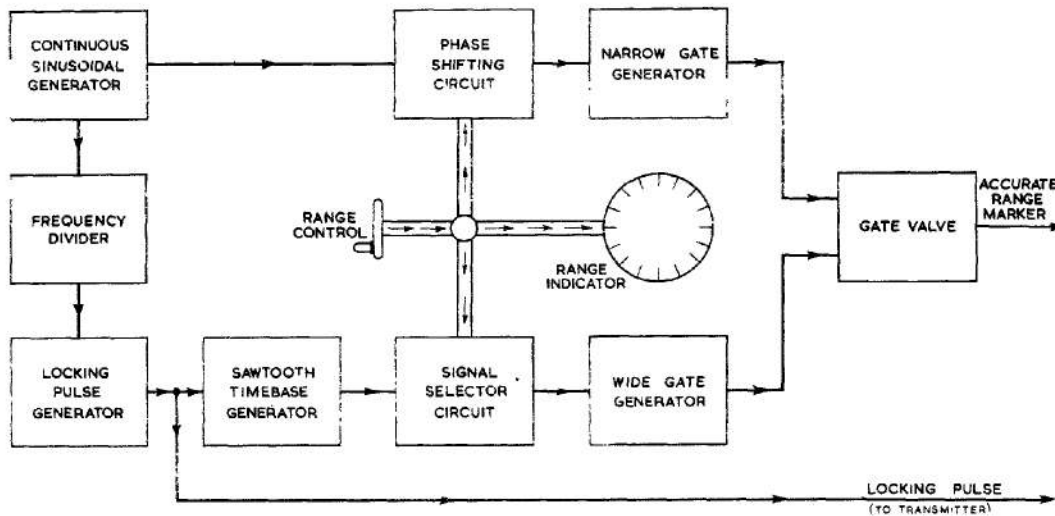

Fig.864 - Range marker locked from sine wave source

4. Range corrections

Locking delay. Any delay between the beginning of the transmitted pulse and the start of the timebase introduces a range zero error. If the timebase begins t_1 microseconds before the transmitted pulse, radar range is too large by $163.86t_1$ yards.

Receiver delay. The passage of the received pulse through the radio receiver to the CRT deflecting system entails receiver delay; if this delay is t_r microseconds, radar range is too large by $163.86 t_r$ yards.

Zero error; bias; datuming

The existence of receiver and looking delays necessitates the application of a correction to the range indicator according to the equation:-

$$\text{Indicated range} = \text{measured (radar) range} - 163.86 (t_r + t_r)$$

The measurement of these delays is not usually practicable except during manufacture, so that unless some alternative method can be incorporated in the set of eradicating zero error or bias, great care must be taken in construction to ensure that the delays involved and the corrections applied are accurate and permanent, not varying with ageing components or changing conditions.

The simplest and most reliable method of eliminating bias is to range on a permanent echo which has been independently surveyed. The necessary zero correction can then be applied so that the indicated and surveyed range are identical. Calibration ensures that range differences are correct, only one surveyed point or range datum thus being needed. If no suitable natural echo exists, artificial datums may be erected.

Once a set has been correctly datumed it may be maintained in true adjustment by the use of a false datum or echo box. This is a delayed pulse relay triggered by the transmitted or looking pulse, which produces an echo on the timebase at a point corresponding to a known true range. Naturally this method relies on the accuracy of the echo box which periodically requires to be checked and calibrated.

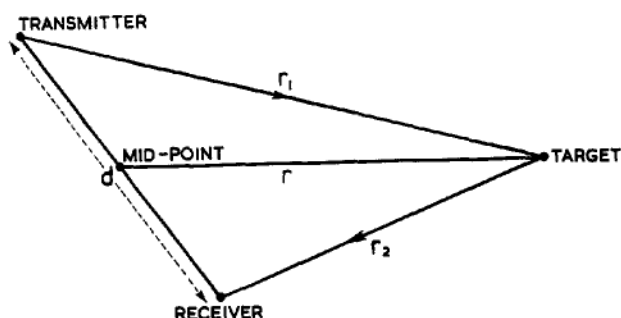

Fig. 865 - Displacement correction

Displacement correction

If the transmitter and receiver are separated by a distance which is not negligible, though much smaller than the range to be measured, the uncorrected radar range is the mean of the ranges transmitter-target and receiver-target. Referring to fig. 865.

$$\text{radar range} = \frac{r_1 + r_2}{2} = r, \text{ the range of the target from a point}$$

midway between transmitter and receiver. If the separation is d yards, the error introduced in taking r as the range from the receiver is

$$\frac{d}{2} \cos E \cos (B-B'), \text{ (provided } d \ll r, \text{ as stated above)}$$

where E is the elevation of the target from the receiver,
 B is the bearing of the target from the receiver
 and B' is the bearing of the transmitter from the receiver.

$$\text{Thus true range} = \text{radar range} + \frac{d}{2} \cos E \cos (B-B').$$

There is thus introduced an error of magnitude $\approx \frac{d}{2}$ yards. To correct automatically for this requires a servo calculating system, driven by both elevation and bearing indicators, which can be adjusted for the required values of B' and d , and which adds the result to a differential in the range output system.

Ballistic correction

In gunnery, to allow for conditions of the moment, it is sometimes necessary deliberately to falsify the range used in setting the quadrant elevation. With a single exponential timebase, a percentage correction can be applied automatically by adjustment of the timeconstant. This is readily done by ranging on a particular echo, or calibrator pip, with the timebase correctly calibrated, and noting the true range R . The timeconstant is then adjusted until the range to the same echo measures $R \pm$ the desired percentage correction on the range indicator.

With a sinusoidal timebase, or marker system originated by a sinewave generator, the same effect is obtained by making a proportionate adjustment to the frequency. This is not possible when the initiating sinewave generator is a fixed frequency primary time-standard, such as a crystal calibrator.

5. Calibration

In order to treat the problem as generally as possible, two terms will be introduced, "true range" and "indicated range". A target at a certain slant range will give rise to an echo at a certain point on the timebase; this corresponds to the "true range" at the point. Some form of marker is aligned with this point, either by direct visual alignment with a fixed scale, or by adjusting a handwheel which brings the echo and marker into coincidence and also positions the range indicating pointer relative to the range scale. In either case the range read from the scale is the "indicated range" at the point of the timebase under examination. The object of calibration is to make indicated range and true range the same.

The fundamental method of calibration is to know the surveyed range to various targets which cause recognisable fixed echoes. The range scale is then drawn so that these points are correctly indicated, and the rest of the scale interpolated as well as maybe. Redrawing of the scale is not practicable in most cases, so that a fixed scale is used, and the ranging system is provided with various adjustments so that this scale can be made to indicate the true range at two or more points. Usually a compromise must be reached, with minimum errors allowed over the portion of the range scale where accuracy is most important (tactically).

With the linear timebase system only two adjustments are required; to amplitude and set-zero controls.

With the system of Fig. 853, where $R_m = 163.86 C_t R_t (\log \mathcal{E}_{R_0} - \log \mathcal{E}_{R_2})$, the supply voltage has been eliminated from the range equation, and the only adjustments needed are to the timeconstant and set-zero controls.

Such a method is usually possible only when the location is fixed and the installations more or less permanent. In making radar equipment it is preferable to make the calibration system independent of the site; but owing to the difficulty of measuring receiver and loading delays Sect. 4, it is not practicable to make any adjustments for zero error unless an external datum is used. Adjustments are made, using a primary time-standard, to ensure that no cumulative error arises due to inaccuracies of any secondary standard used.

Where a primary standard is an inherent part of the range measuring system no such adjustments are necessary. Where the secondary standard is a tuned circuit, calibration consists of making the natural frequency of the ringing circuit the same as the frequency of the primary standard.

Where the secondary standard is a sawtooth waveform of known law, calibration consists of ensuring as far as possible that this law corresponds to the law of the range indicator calibrations. In the simple system of Fig.849, the normal receiver output, containing the echo pulse is removed, and is replaced by the output waveform from a crystal calibrator, which for simplicity may be assumed to consist of a series of pips at a frequency of 163.86 kc/s, corresponding to 1000 yard intervals between pips. The timebase is locked with the calibrator so that a steady tube picture results.

Fig.866 shows the correspondence between the range scale, timebase sweep voltage and CRT picture with calibration pips. Provided that both sweep and scale are exponential, the sweep must conform to three calibration requirements:-

- (i) The time constant must be correct.
- (ii) The amplitude must be correct.
- (iii) There must be no zero error.

Fig.866 (ii) and (iii) show the effects of the time constant and amplitude controls. When both of these adjustments have been made correctly, as at (iv), the differences between the indicated range to the successive pips will be exactly 1000 yards. If one of these scales is not exponential, it will be impossible to achieve this correspondence.

To assess the zero error, the calibrator waveform must be replaced by the normal receiver signals and the range measured to a known echo. The difference between this and the surveyed range must then be added to or subtracted from all the measurements made on this scale. If this difference is applied as a shift voltage (equivalent to moving the scale), the amplitude of the timebase waveform will have to be readjusted and the process repeated until true correspondence is obtained.

6. Principles of signal selection

Signal selector circuits are required to pick out for closer examination a portion of a timebase in the neighbourhood of a known range; they involve a range-measuring device which decides the moment at which the selector valve opens, slightly before the arrival of the point to be examined. The range-measuring circuit requires a timebase, which may, but need not, be the same as the timebase under examination; it is preferable to use a separate timebase unless conservation of material is of primary importance, since this allows greater flexibility in design.

For production of accurately ranged pulses, as markers or for narrow-gate selector circuits used in bearing and elevation integrating systems, two stages are necessary; these usually consist of a coarse, saw-tooth selector circuit ganged to a fine phase-shifting circuit.

7. Sawtooth circuit

The arrangement is shown Fig.867. The instant at which V_1 starts to conduct is controlled by the timebase circuit and the ratio R_2/R_1 . As discussed in Sect.2 either this ratio or the timebase may be varied to control this instant, and any one of the range-measuring methods described therein may be used.

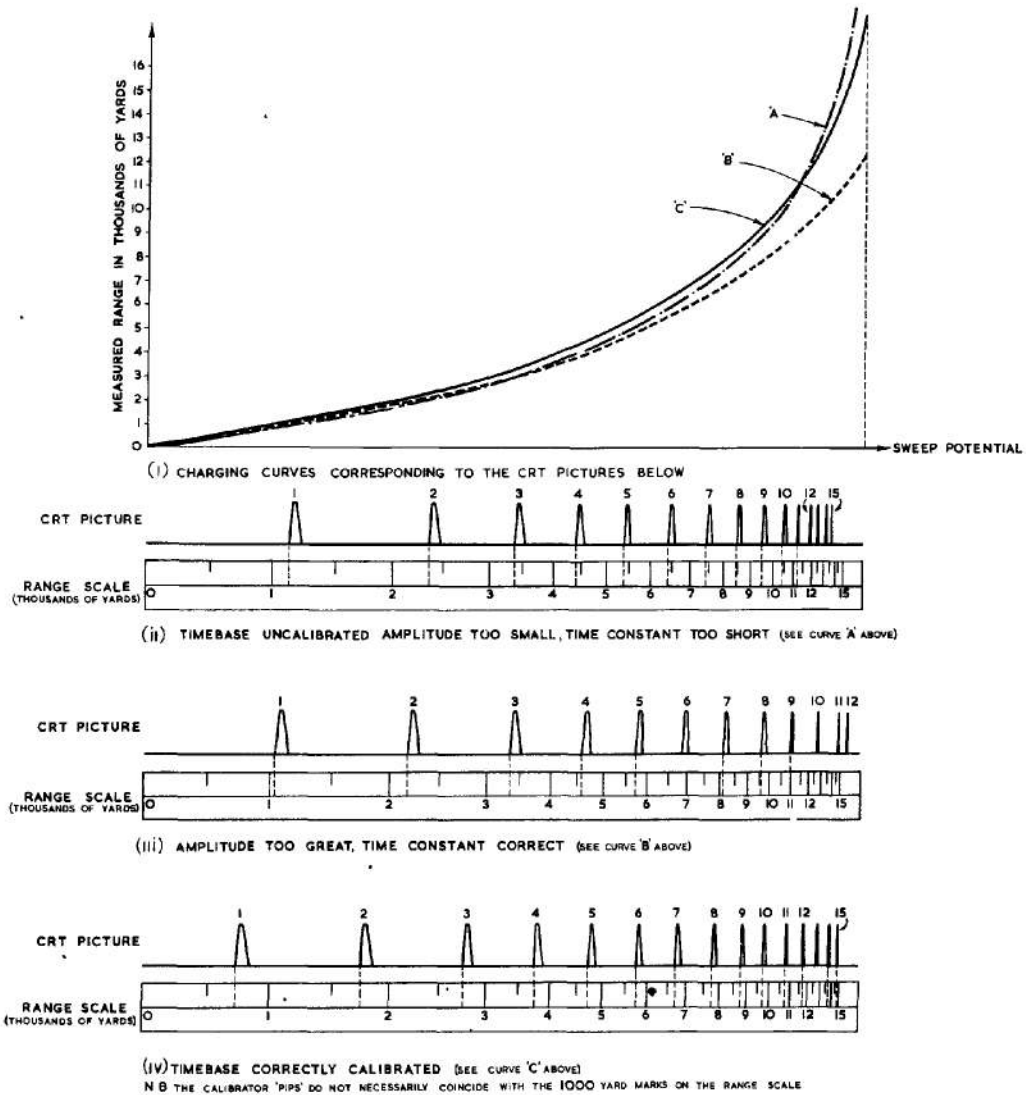

Fig.866 - Calibration of exponential timebase

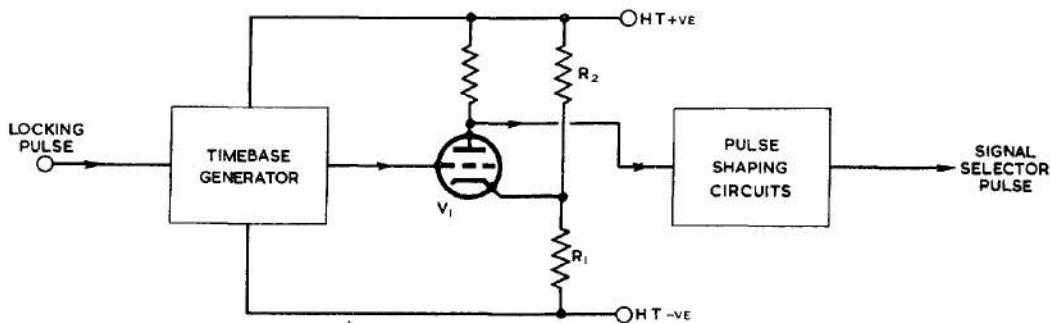

Fig.867 - Sawtooth signal-selection circuit

Examples of these are shown in Fig. 868.

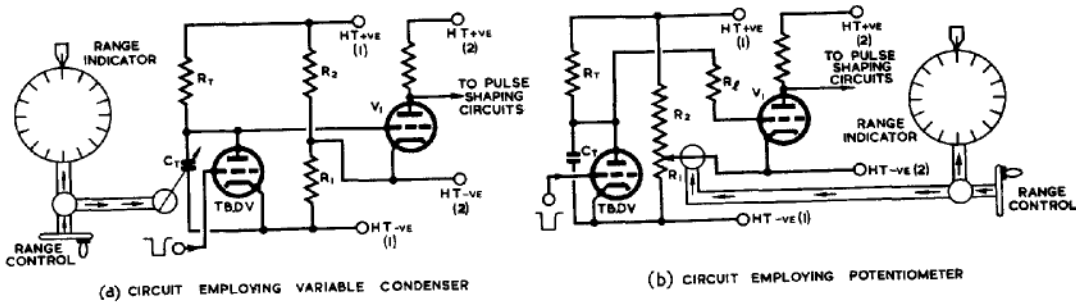

Fig. 868 - Signal selector circuits affecting timebase

If it is required to use the same timebase for the CRT as for the signal selector, certain sources of inaccuracy must be minimized. In the circuits of Fig. 868, the timeconstant of the charging circuit changes as V_1 conducts, and so does the effective charging voltage. The net effect on the timebase waveform is shown in Fig. 869. For simplicity it has been assumed that when grid current flows $R_f \gg$ the input series resistance of V_1 between grid and $HT(1)-ve$. The effect on the CRT sweep of this distortion is similar to that produced by deflector plate current, causing a shrinking at the longer ranges.

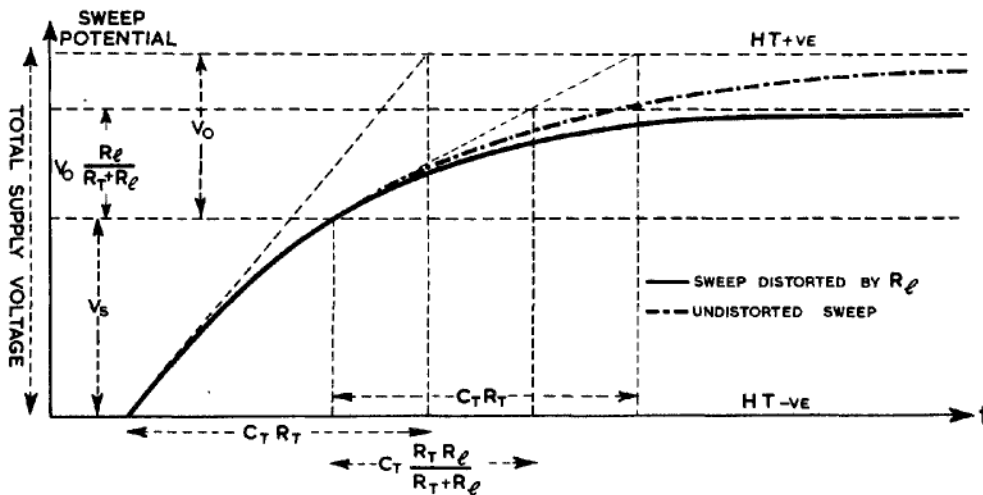

Fig. 869 - Effect of circuits of fig. 868

If R_f is omitted altogether as in Fig. 868(a), V_1 acts as a limiter and distorts the timebase waveform as shown in Fig. 870; the effect is most pronounced if $R_T \gg$ the input resistance of V_1 .

It will be noticed that in the circuit of Fig. 871 the amplitude of the waveform at the anode of V_1 depends on the setting of the range control R_1 . For this reason V_2 must act as a limiter.

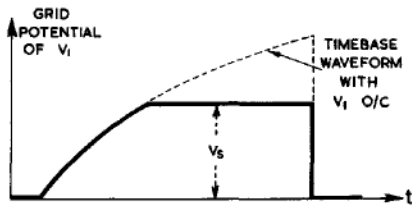

Fig. 870 - Limiting by V_1 in fig. 868(a)

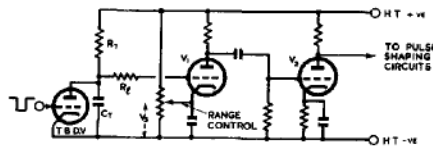

Fig. 871 - Limiting by V_2

Following the signal selector valve there are normally pulse-shortening and shaping circuits, depending on the use intended for the selected pulse.

8. Sinusoidal circuits

This is essentially the same as the sawtooth circuit except for the sinusoidal nature of the timebase waveform. It is practicable to use the same basic circuit, i.e. Fig. 867 choosing the instant at which the selector valve trips by controlling the bias. This is shown in Fig. 872. It is clear

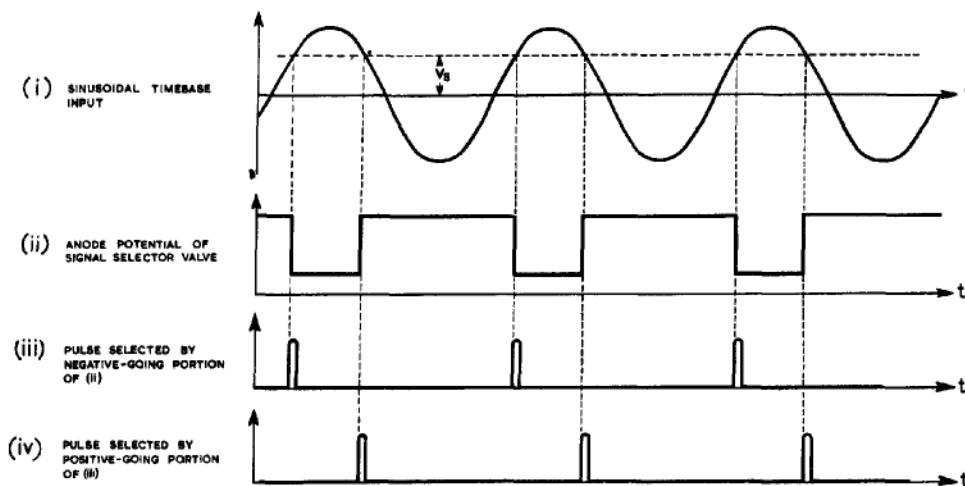

Fig. 872 - Sinusoidal signal-selection waveforms

that if either the positive-going or the negative-going portion of the output-waveform is used any instant of the waveform may be selected, but the accuracy of the method is not good, particularly when the sinewave is limited near the peaks or troughs. If the timebase is a "damped sinewave" the method is impracticable, and the waveform must be limited close to its mean value if inaccuracies are to be minimized. The method is most applicable to low-frequency sinewaves where phase-shifting circuits would require inductive or capacitive components of prohibitive size.

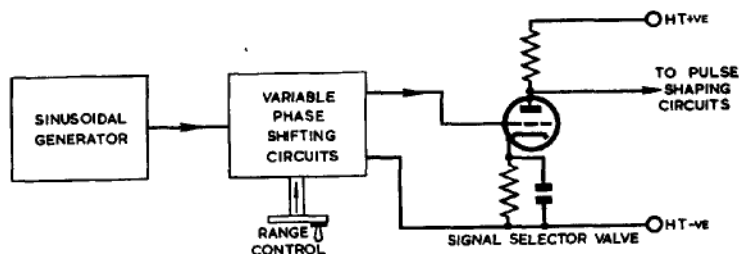

Fig.873 - Sinusoidal signal-selection circuit

The more common circuit is shown in Fig.873. The signal selector valve is biased so that the sinewave is limited close to its mean value. The instant at which the valve opens is controlled by the 0-360 deg. phase-shifting circuit, this is positioned by the range control.

When coarse and fine signal selectors are used, the frequency f of the sinewave is much greater than the recurrence frequency, and if

$$f = \frac{163.86}{n} \text{ Mc/s}$$

the phase-shifting control may be calibrated in "fine range" from 0 - n yards. This control is ganged to the "coarse range" control of a saw-tooth signal selector and the two output pulse trains are mixed in a gate valve. The result is a single pulse for each cycle of the recurrence frequency, of width determined by the "narrow gate" shaping circuits, and at the range determined by the position of the coarse and fine range controls.

9. Range markers

Any signal selector circuit may be utilized for the production of range markers. These may be divided into "wide gate" and "narrow gate" circuits. Wide gate pulses are usually provided by sawtooth circuits where great accuracy is not required. Narrow gate pulses for accurate markers require the two stage method of Sect. 8.

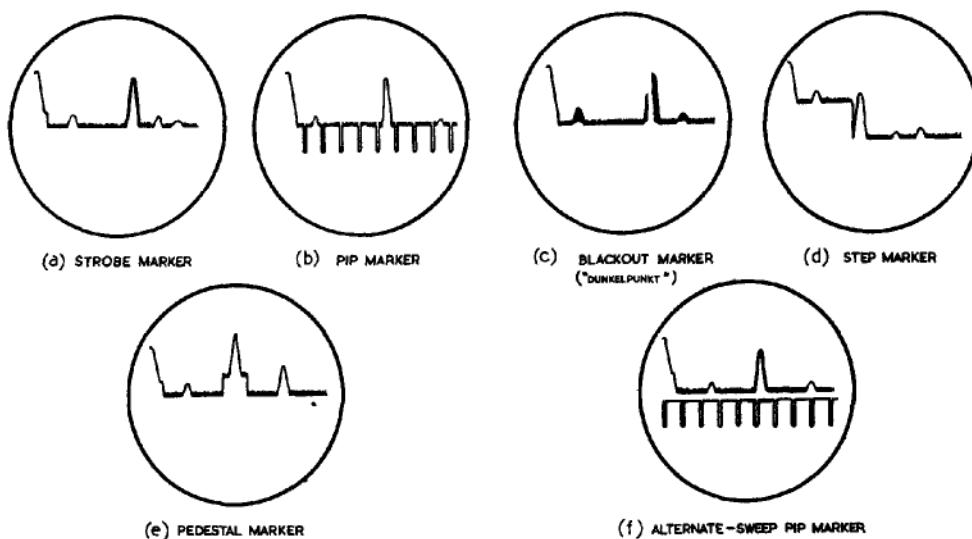

Fig.874 - Types of range marker

Chap.18, Sect.9

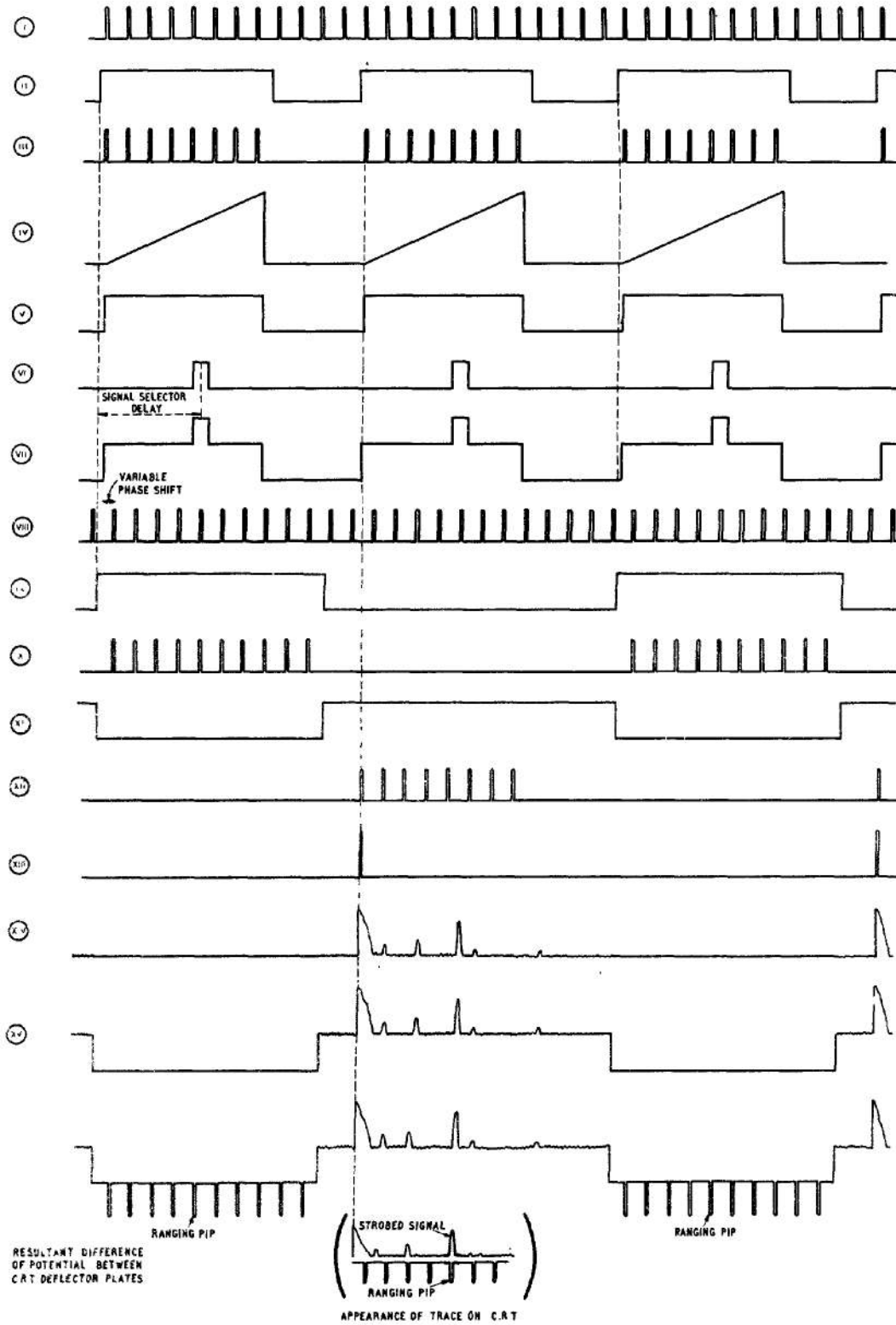

Fig.876 - Waveforms for fig.875

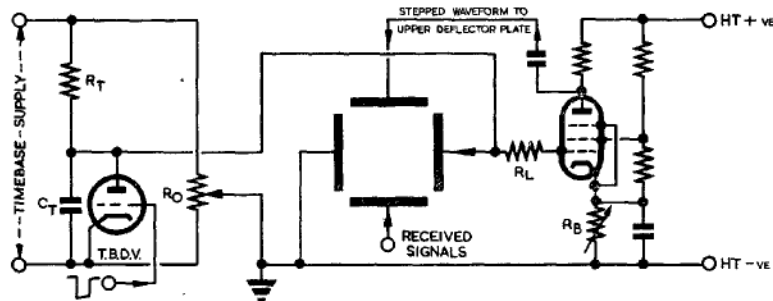

Fig. 877 - Signal-selector circuit for centring marker

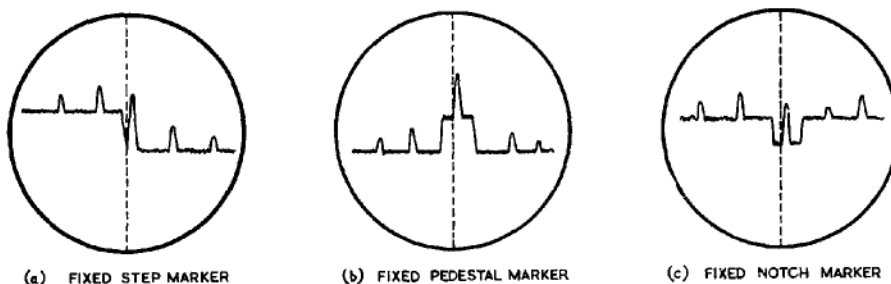

Fig. 878 - Fixed step marker and variants

The simple step marker with its variants, the fixed pedestal and the fixed notch marker are shown in Fig. 878. These are produced in the same way as the simple step, but the step waveform is shortened to the desired pedestal or notch width. The echo is maintained either at the leading edge of the step or in the centre of the pedestal or notch.

Sawtooth timebase circuits for accurate range measurement

10. General requirements

For accuracy, a fast or large scale timebase is essential, displaying not more than two or three microseconds to the inch. This means that only a few thousand yards of the trace can be displayed, on the A-scope principle, while accurate measurement is being made. For searching, a lower timebase supply voltage may be substituted, shrinking the timebase and permitting a much greater range coverage.

A further requirement is the use of a method of range measurement in which CRT irregularities are unimportant. Instead of the range control being used to open a signal selector valve, it may be used to apply a shift potential to one deflector plate while the timebase potential is fed to the opposite plate, so that the echo appears at the electrical centre of the tube, where it may be aligned with an external crosswire. The use of the same supply for the timebase and shift potentiometer enables errors due to variations in supply voltage to be avoided.

Because of the high voltages involved the potential of the "potentiometer plate" must be near that of the final anode, so that defocusing is avoided. Since measurements are made at the electrical centre of the tube, this is the same as the "mean deflector plate potential" for that point of the timebase. Errors due to deflector plate current are prevented by making the "potentiometer plate" potential somewhat less than that of the final anode. Since the latter is normally grounded a satisfactory arrangement is to maintain the potentiometer plate slightly below earth potential, allowing

the timebase supply rails to assume corresponding potentials with respect to earth.

Although the methods are applicable to other forms of timebase, the exponential form of the simple C-R circuit timebase conforms to the theoretical curve with such accuracy that it is unnecessary to use anything more elaborate.

11. Linear condenser

The circuit is shown in Fig.879. The variable condenser is so designed that its capacitance is proportional to the angular rotation of its moving vanes. These are geared to the range indicator. From the range

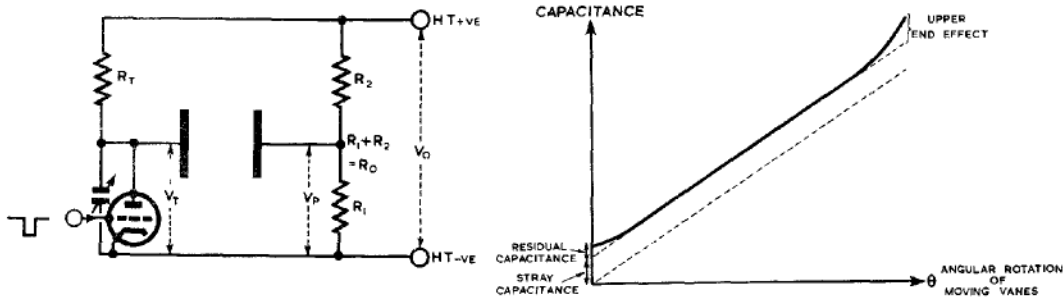

Fig.879 - 'Linear condenser' circuit equation of Sec.2

Fig.880 - Errors in 'linear condensers'

$$R_m = 153.86 C_t R_t (\log_e R_0/R_2)$$

so that the range scale is linear.

Since linear condensers are commonly manufactured commercially, they do not require to be made specially unless great accuracy is required at widely different ranges. The errors prevalent in ordinary commercial types are mainly due to end effects, and the overall effect is shown in Fig.880. Since there is a minimum range below which no measurements are made, the residual capacitance when the vanes are fully open, together with unavoidable stray capacitance in parallel with C_t , is usually unimportant, while great accuracy at long ranges is not usually required. However, if it is desirable, the errors may be minimized by careful shaping of the condenser vanes.

The choice of the fixed ratio $\frac{R_0}{R_2}$ affects the timebase supply voltage required. If a mean timebase scale of t_s microseconds per centimetre is required, while the mean deflection sensitivity is V_s volts per centimetre, t_s and V_s correspond as shown in Fig.881. It will be shown that for a given t_s and V_s the minimum value of V_0 required occurs when

$$\frac{R_0}{R_2} = e = 2.718$$

From Fig.881

$$\frac{V_s}{t_s} = \frac{dV_t}{dt} \text{ at P, corresponding to the portion of the}$$

timebase near the crosswire.

Since $V_t = V_0 (1 - e^{-t/C_t R_t})$

$$\begin{aligned} \frac{dV_t}{dt} &= \frac{V_0}{C_t R_t} \cdot e^{-t/C_t R_t} \\ &= \frac{V_0}{t_e} e^{-t_e/C_t R_t} \cdot \frac{t_e}{C_t R_t} \text{ at the crosswire,} \end{aligned}$$

where $t = t_e$.

But $V_s = V_0 (1 - \frac{R_2}{R_0})$ and at the crosswire, $V_t = V_s$

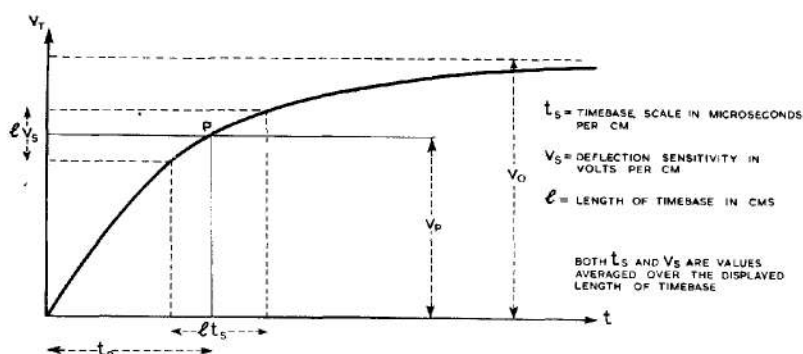

Fig. 881 - Range/Deflection sensitivity curve

Hence $\frac{R_2}{R_0} = e^{-t_e/CtRt}$

Putting $\frac{R_0}{R_2} = x = e^{-t_e/CtRt}$

$\log x = \frac{t_e}{CtRt}$

Thus $\left(\frac{dv_t}{dt}\right)_P = \frac{V_0}{t_e} \cdot \frac{\log x}{x} \approx \frac{V_s}{t_s}$

$\therefore \frac{1}{V_0} = \frac{t_s}{V_s t_e} \cdot \frac{\log x}{x}$

This has a maximum value when its derivative with respect to x is zero, i.e. when $\log x = 1$, or $x = e$, so that the minimum value of .

V_0 is $\frac{V_s t_e}{t_s} e$ and occurs when $\frac{R_0}{R_2} = e = 2.718$

Assuming that this value has been chosen for $\frac{R_0}{R_2}$, then $\frac{V_s}{t_s} = \frac{V_0}{t_e} e$,

so that the scale of the timebase is inversely proportional to t_e , i.e. to the range measured. This is usually undesirable, and may be compensated for by arranging to provide V_0 proportional to range so that the scale is the same at all ranges.

12. Linear resistance (Variation of R_T in Fig. 879)

The same considerations apply to this method as have been discussed in Sec. 11. The variable condenser method is usually to be preferred since condensers may be made smoothly variable, while resistances of sufficient accuracy may be varied only in steps.

13. Exponential rheostat method (variation of R_1)

The circuit is shown in Fig. 882. R_1 is an exponential function of range, and calibration is the principal difficulty. If an exponential scale on the range indicator is undesirable, there are two alternative methods using equally spaced studs; either the successive values of R_1 may be made exponential, the values of the resistances themselves forming a geometrical progression, or, if the resistance steps are equal, a cam may be used so that exponential movements of R_1 give rise to linear movements of the range indicator.

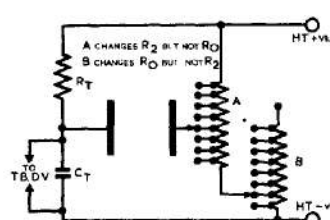
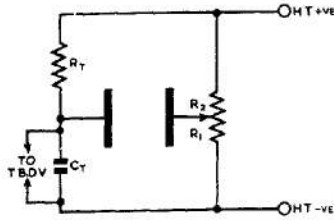
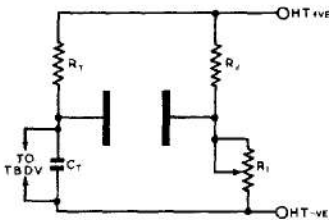

Fig.882 - Exponential rheostat circuit

Fig.883 - Exponential potentiometer circuit

Fig.884 - Decade potentiometer rheostat circuit

14. Exponential potentiometer method (Variation of $\frac{R_2}{R_1}$)

The same considerations apply to this network, shown in Fig.883 as were discussed in Sect.13. The fact that it involves a constant load on the time-base power supply, as distinct from the variable drain caused by the rheostat method, makes this circuit somewhat preferable.

15. "Decade" potentiometer-rheostat method

It follows from the range equation of Sect.2 that variations in R due to changes in R_0 and those due to changes in R_2 are entirely independent. More explicitly, if $\Delta_0 R$ is the difference in range due to R_0 increasing to R'_0 ,

$$\Delta_0 R = 163.86 C_T R_T (\log_e R'_0 - \log_e R_0)$$

and is the same for all values of R_2 ,

while if $\Delta_2 R$ is the difference in range due to R_2 increasing to R'_2 ,

$$\Delta_2 R = 163.86 C_T R_T (\log_e R_2 - \log_e R'_2)$$

and is the same for all values of R_0 .

Hence if there are ten values of R_1 , each providing a 1,000 yard step in R, and ten values of R_2 , each providing a 100 yard step in R, it is possible to cover a 10,000 yard range of values of R in 100 yard steps by this decade arrangement.

The method is illustrated in Fig.884 where seven steps are shown to each resistor; either may be the coarse, and the other the fine range control. In theory both resistors require to be wound exponentially, so that successive steps cause a uniform change in the range measured; but the error in making all the resistors of the fine control equal is usually negligible.

The disadvantage of the simple network of Fig.884 is that the change in range is discontinuous, the difficulty in avoiding this being common to all decade systems. Unless simultaneous switching sequences are used, the

passage from 8,800 to 9,200 yards, for example, in 100 yard steps, would be via one of the two sequences

8,800, 8,900, 9,900, 9,000, 9,100, 9,200
 or 8,800, 8,900, 8,000, 9,000, 9,100, 9,200;

since thousands and hundreds steps must be made separately.

Further complications are introduced if the slider bridges two contacts, short-circuiting one of the resistors.

A method of overcoming these disadvantages is shown in Fig. 885. There are two separate networks, A and B. These are used alternately, the potentiometer slider, which is, as usual, connected to the deflector plate, taking the path indicated by the dotted line, the arrows indicating the direction of motion for increasing range.

The slider travels from 0 to 10 on P_B with R_B set at 0. It then passes to 0 on P_A , which is at the same potential as 10 on P_B , because R_A is set at 10. The slider then travels from 0 to 10 on P_A ; during this period the R_B tap changes to 20, so that the slider can then pass from 10 on P_A to 0 on P_B since these studs will now be at the same potential. During the movement of the slider over P_B the tap on R_A changes from 10 to 30, and the continuous rise in potential is similarly maintained throughout the complete range of R_A and R_B .

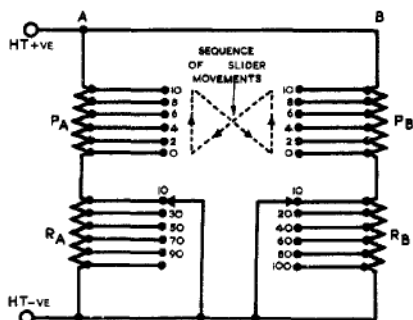

Fig. 885 - Improved version of fig. 884 circuit

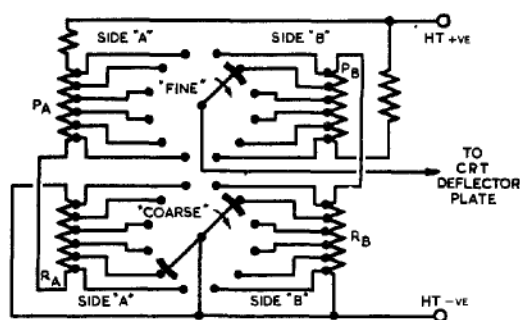

Fig. 886 - Practical arrangement of fig. 885 circuit

The potentiometers P_A and P_B are made semi-circular so that the slider passes directly from the higher potential end of one to the lower potential end of the other. In all cases there must be a momentary short circuit between the "make" of the slider at one stud and the "break" at the previous stud. This is immaterial at the end positions, as has been shown, since these are then at the same potential. In the intermediate positions the short-circuit merely bridges the gap between consecutive studs and serves to smooth the potential jump from stud to stud.

A typical arrangement is shown in Fig. 886.

16. Earthing the potentiometer slider

Because of the high voltages necessary to produce an adequate scale there is a likelihood of large leakage currents from either rail to earth. Since the potentiometer slider is to be maintained near earth potential this would introduce leakage resistances in parallel with one or other portion of the potentiometer chain, and change the ratio $\frac{R_0}{R_2}$, with consequent range errors.

To avoid these errors the potential of the slider must be fixed by indirect means.

Coarse and fine timebases

17. General principles

The problems of searching for an echo over a large timebase range are quite different from those of following accurately a selected signal; neither can the two operations properly be performed by the same person. Where both are required it is preferable to separate them, displaying the whole of the timebase on a coarse range tube, and a selected portion on a fast timebase where the echo can be accurately aligned with a marker or crosswire.

The accuracy of range measurement depends on the fine range system, which must either be a fast sawtooth circuit controlled by an accurate pip marker system or contains a sinusoidal timebase generated by a primary or good secondary time-standard. In either case a sinusoidal generator is an inherent part of the timebase system.

The main function of the coarse timebase is to line up the echo with the appropriate portion of the fine timebase, after which accurate following is continued on the latter. A moving marker on the coarse tube indicates the portion which is expanded on the fine sweep. This could be of the notch or pedestal type but is usually a bright patch or "strobe". The signal selector control which positions this marker must be ganged to the fine range system with sufficient accuracy to ensure that when an echo is in the middle of the strobe patch it is clearly displayed on the fine range sweep.

Fine timebases divide naturally into two types, rectilinear and circular. It is only with the latter that a fixed timebase is practicable. With the rectilinear, and some circular timebases a phase-shifting circuit is necessary to bring the echo to a fixed marker by shifting the timebase relative to the marker. With circular timebases it is possible to measure the phase shift on the face of the tube by using a radial cursor, as with the spiral timebase.

18. Sawtooth timebase with marker

A marker pip-train is generated by the time-standard after passage through a 0 - 360 deg. phase-shifting network geared to the fine range indicator: this is ganged to a sawtooth signal selector circuit which moves the coarse range indicator and selects two consecutive marker pips (Fig. 887). The first of these triggers the fine sawtooth timebase; the second appears in the middle of the timebase as a marker, shown in Fig. 888 as a trace brightening pulse. The schematic arrangement is shown in Fig. 889. A B-scope presentation is shown in Fig. 888(b). This uses the same marker system as the A-scope method of Fig. 889, with different deflector plate connections. This system is particularly applicable to P.P.I. and other intensity modulated systems.

19. Flat spiral timebase

In this arrangement the output waveform from the phase-shifting network is applied to the X - deflecting system of the fine range tube. The whole timebase is thus traced backwards and forwards across the tube, each $\frac{1}{2}$ cycle covering $\frac{n}{2}$ yards in a sinusoidal sweep, where $n = \frac{163.86}{f}$, f being the frequency in Mc/s.

The coarse range signal selector circuit picks out one half-cycle by relieving the bias on the CRT grid so that only one forward sweep is displayed. The zero of this sweep coincides with the electrical centre of the tube, and the echo is aligned with this by means of a crosswire, as shown in Fig. 890.

Chap.18, Sect.16

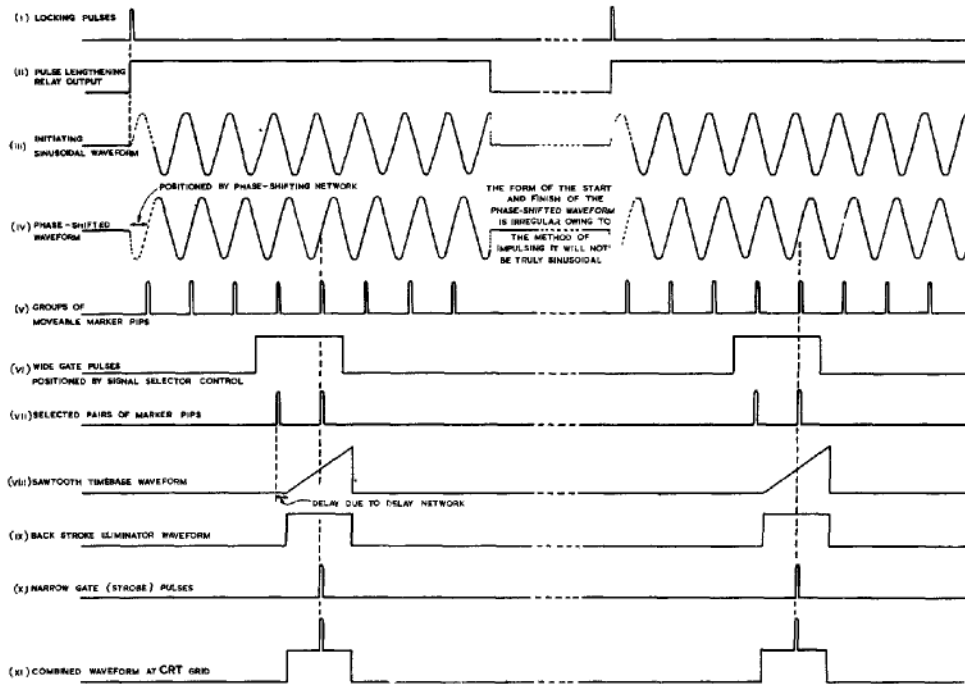

Fig.887 - Sawtooth timebase and marker waveforms

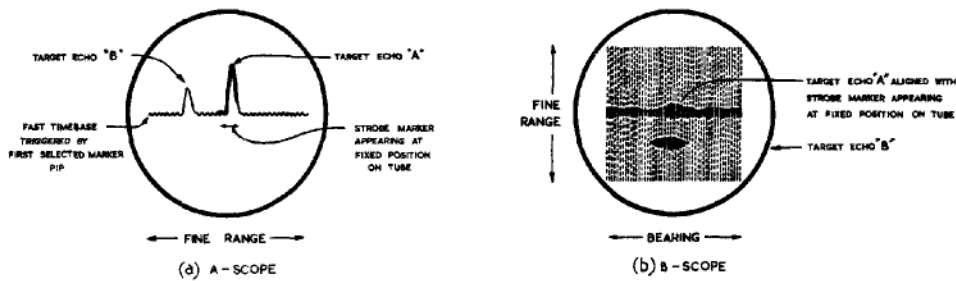

Fig.888 - A- and B-scope marker presentation

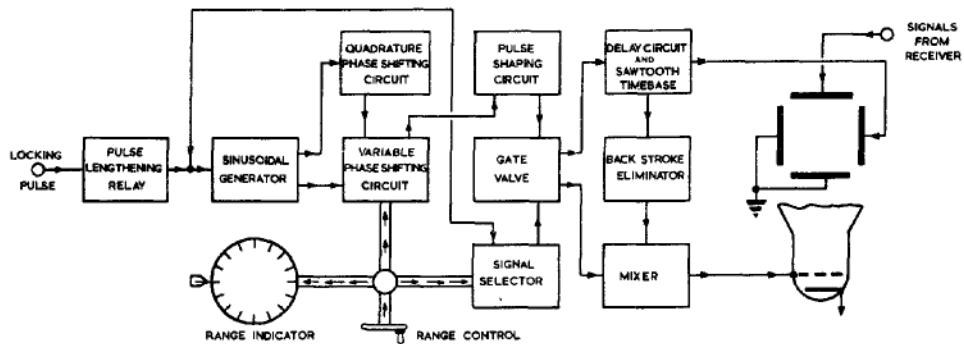

Fig.889 - Block schematic for fig.887

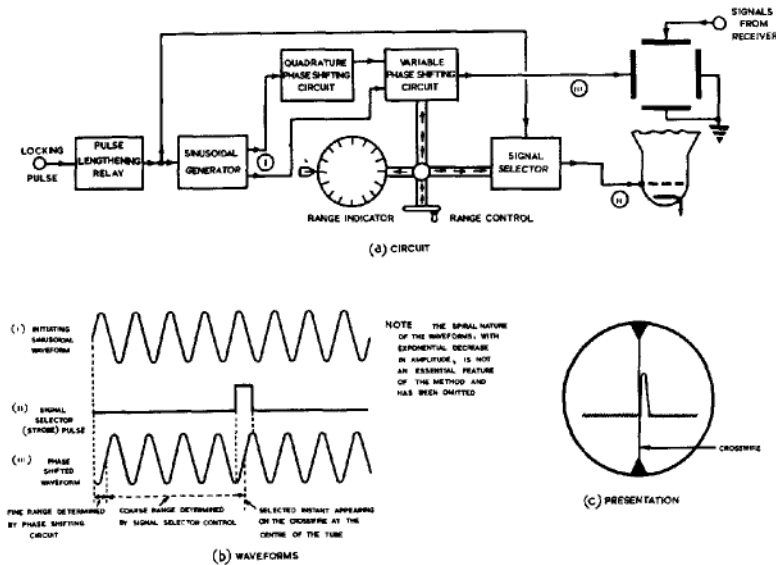

Fig.890 - Flat spiral timebase

The initiating time-standard may be a crystal calibrator, in which case the only adjustment necessary to the fine timebase is the provision of the correct zero-shift.

Where secondary time-standard is used, such as a ringing circuit, which gives the name to the timebase, a calibrating marker system with a primary standard is required. The marker pips are applied to the deflecting system and a subdividing standard is required. The marker pips are applied to the deflecting system and a subdividing circuit used to trigger the timebases. The standing bias on the CRT grid is removed so that the whole timebase is displayed in superimposed portions of length $\frac{1}{2}$ yards. The ringing circuit is tuned until all the calibrator pips line up together on the crosswire when the phase-shifting circuit is correctly positioned.

20. Fine J-scope timebase

This is similar to the flat spiral method except that the whole of each cycle is displayed on a single overlapping circular timebase; only a portion of one turn is seen, the trace being brightened over this portion by the strobe pulse from the coarse range signal selector circuit. Either the phase-shifting circuit may be used to bring the echo to a fixed cursor, or the trace may be stationary and a radial cursor rotated into coincidence with the echo (Fig.891). If the latter method is adopted the phase-shifting circuit is eliminated. Schematic diagrams are shown in Figs.892 and 893.

21. Timebase with expanded portion

This rectilinear timebase combines coarse and fine range measurement in a single trace, a portion of a small-scale timebase in the neighbourhood of the selected echo being expanded into a "fine timebase". The echo is aligned with a fine range marker positioned by a phase-shifting network.

Fig.894 shows the tube picture where a dunkelpunkt (dark-point) marker is also used. As in the fine sawtooth timebase circuit, the signal selector pulse picks out two markers, the first of which triggers the "fine" timebase, the second producing the darkening pulse to the CRT grid circuit. If required, all the marker points may be displayed, and used for coarse range estimation. In this case it is better to display markers and signals on alternate timebase sweeps, as described in Sect.9.

The schematic arrangement and waveforms are shown in Fig.895.

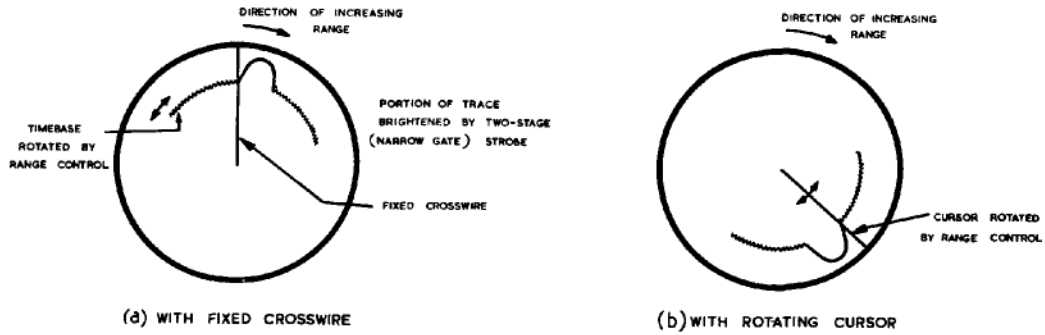

Fig.891 - Fine J-scope timebase

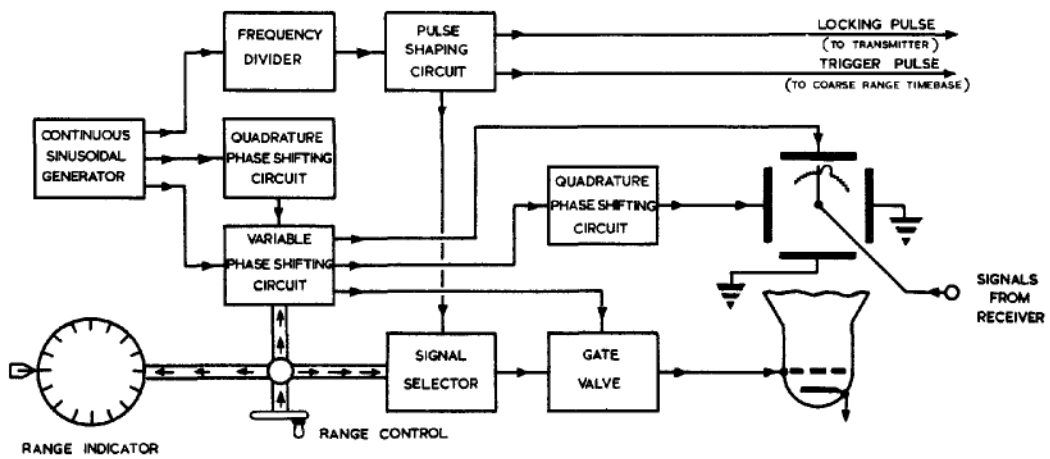

Fig.892 - Circuit for fig.891 using fixed cursor

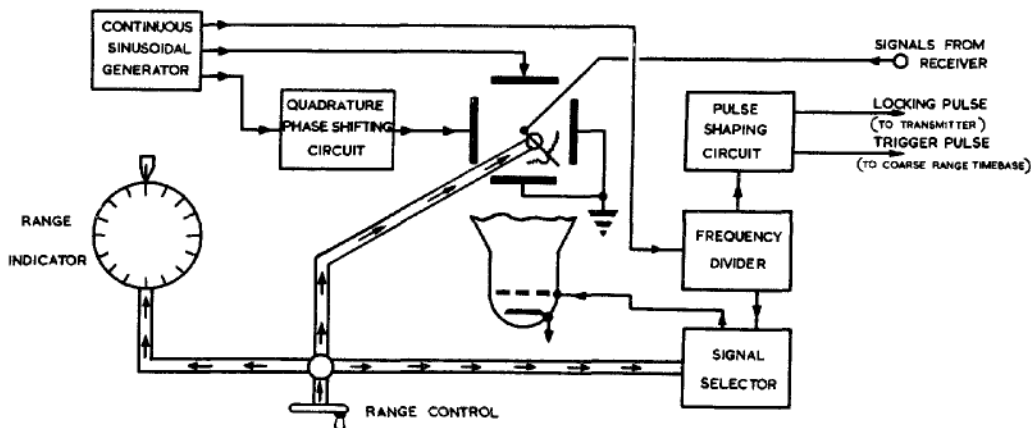

Fig.893 - Circuit for fig.891 using movable cursor

FINE RANGE 'BLACKOUT' MARKER

PORTION OF TIMEBASE
EXPANDED AND STROBED

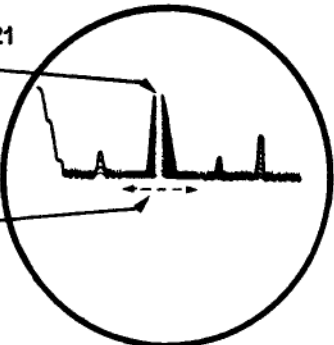
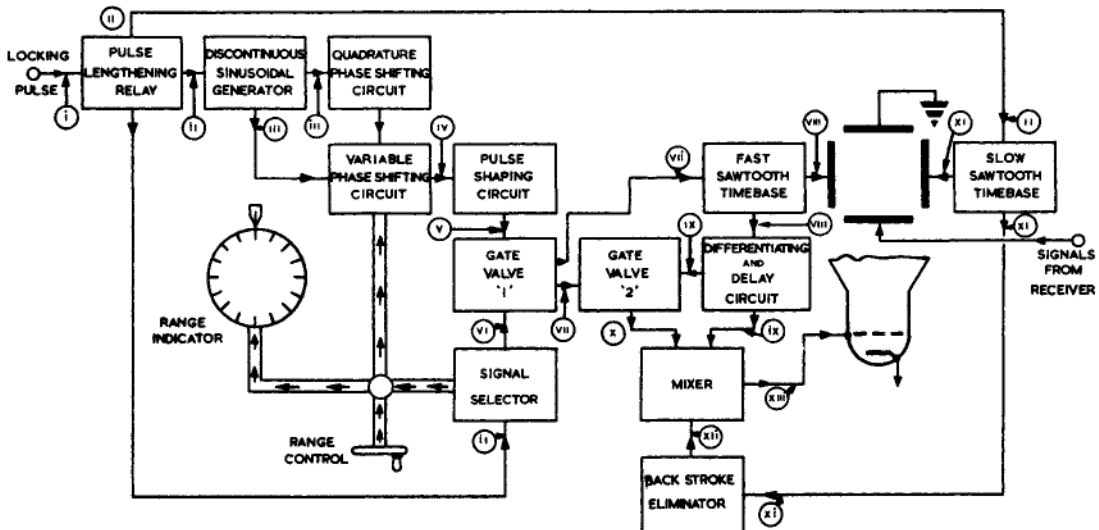
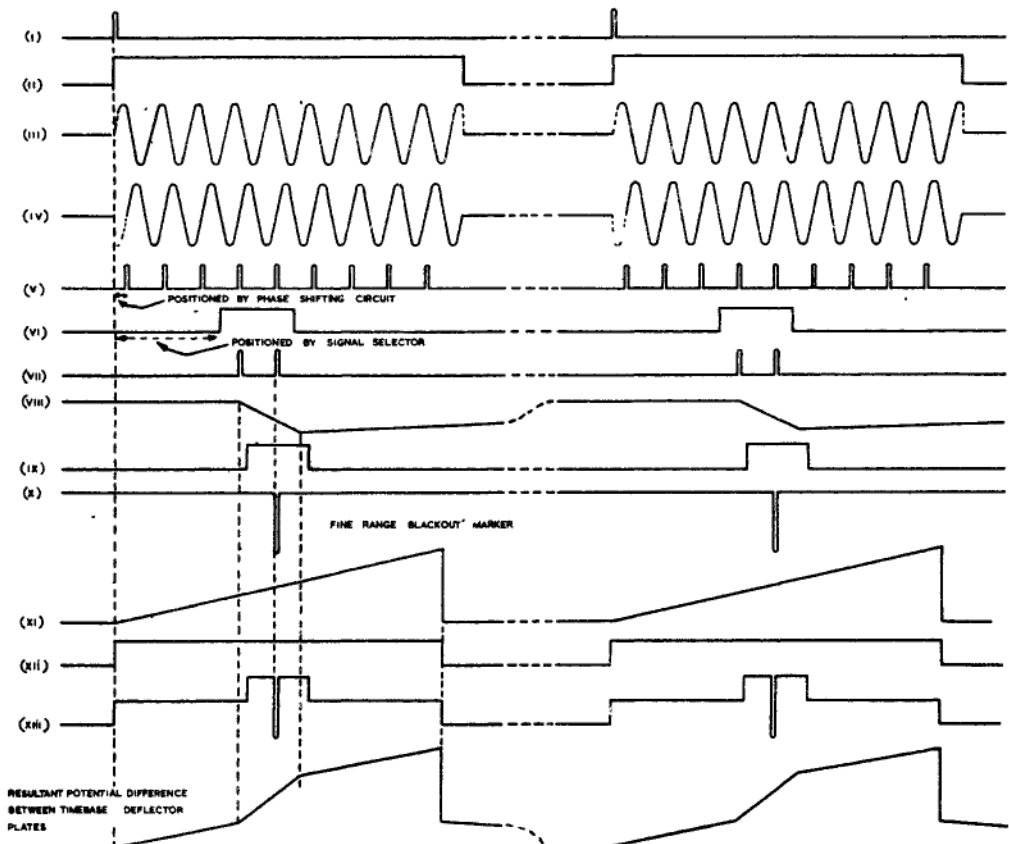

Fig.894 - Display of 'blackout' marker



(a) CIRCUIT



THE NUMBERS, • g(xiii) INDICATE THE WAVEFORMS APPEARING AT CORRESPONDING POINTS IN (a)

(b) WAVEFORMS

Fig.895 - Circuit and waveforms for blackout marker display



This file was downloaded
from the RTFM Library.

Link: www.scottbouch.com/rtfm

Please see site for usage terms,
and more aircraft documents.