

Chapter 3  
NETWORKS  
List of Contents

	Sect.
Introduction	1
Measurement of input and output impedances	2
Symmetrical T-sections and $\pi$ -sections	3
Matching	4
Gain and loss	5
Iterative sections	6
Attenuators	7
Filters	
Ideal requirements	8
Simple high-pass and low-pass filters	9
Simple low-pass filter formed of purely reactive elements	10
Graphical representation of properties of a simple low-pass filter	
T-section	11
Properties of simple low-pass filter $\pi$ -section	12
Properties of simple high-pass, band-pass and band-stop filters	13
Other types of filters	14
Delay networks	15
Use of delay line for producing rectangular pulses	16
Resolving networks	
General	17
Resistive resolver	18
Inductive resolver	19
Continuously variable phase-shifting devices	
General	20
The goniometer	21
The capacity phase-shifter	22
The potentiometer phase-shifting network	23
0-180° phase-shifting network	24



CHAPTER 3

NETWORKS

1. INTRODUCTION

In all radar circuits involving the transmission of electrical energy, examination of the circuit behaviour at any stage requires the division of the system into "source" and "load", as shown in Fig. 49. If the system is linear it is conveniently described in terms of ideal

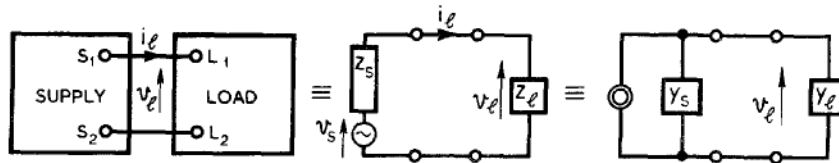

Fig.49.- Division of system into source and load.

generators and input and output impedances, as shown in Chap. 1, Sec.12. The voltage  $v_e$  developed across the load, the current  $i_e$  through it, and the phase relation between them specify the load or input impedance  $z_l$  to a sinusoidal EMF of given frequency. The source may be represented by a generator of EMF equal to the voltage  $v_s$  between the output terminals  $S_1, S_2$  when open-circuited, in series with the equivalent source impedance  $z_s$ , called its output impedance. Alternatively the source may be

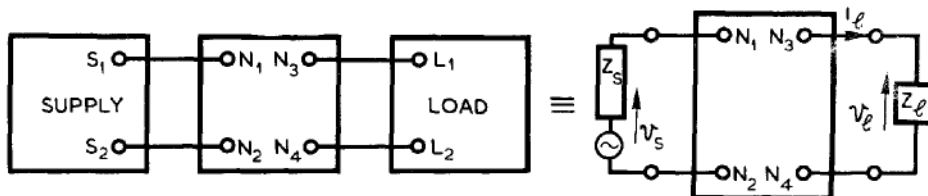

Fig.50.- Network interposed between source and load.

represented by a generator of current  $i_s$  equal to the current through the short-circuited output terminals, in parallel with its output impedance  $z_s$  (or output admittance  $y_s = \frac{1}{z_s}$ )

An element in the chain between source and load may usually be represented as a four-terminal network (Fig. 50). Such a network may contain linear or non-linear elements, e.g. transmission lines, valve amplifiers, etc. For simplicity, only those networks will be considered in any detail which do not contain sources of EMF and which are formed of resistive (R), inductive (L) and capacitive (C) elements. For one-way transmission of energy, from source to load, such a network may be represented by a potential divider

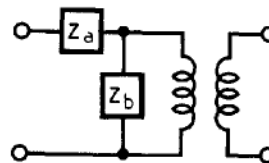

Fig.51.- Representation of 4-terminal network for one-way transmission.

followed by an ideal 1:1 transformer, (Fig. 51); whilst if two-way transmission is to be considered the four-terminal network may be represented by either a T-section or a  $\Pi$ -section followed by an ideal 1:1 transformer, as shown in Fig. 52.

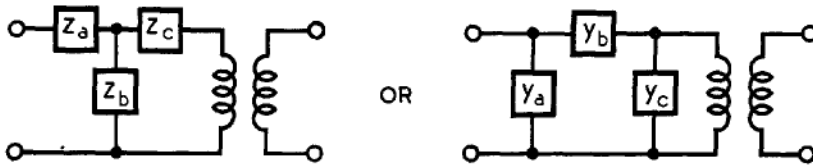

Fig.52. - Representation of a 4-terminal network.

The input and output conditions so far described have ignored any connections between source and load except through the network. In practice, the relations between the potentials at the input terminals and of neighbouring conductors ("earth") are important, and must correspond to the relations between the potentials at the output terminals and "earth". In general, this is equivalent to adding extra terminals to the network, as shown in Fig. 53(a). Two cases are commonly encountered :-

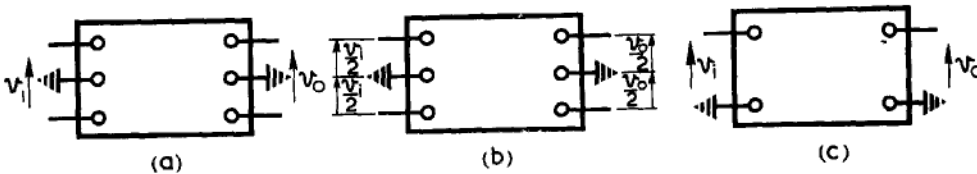

Fig.53. - Effect of earth: balanced and unbalanced networks.

- (i) **Balanced networks:** in these, the potentials at the input and output terminals are symmetrically disposed with reference to earth (Fig. 53(b))
- (ii) **Unbalanced networks:** in these, one each of the input and output terminals is earthed (Fig. 53(c)).

The properties of balanced networks can readily be derived from those of unbalanced networks, and only the latter will be considered in subsequent paragraphs. For example, the fundamental properties (ie. Characteristic Impedance, Propagation Constant, etc. as deduced in Sect.3) of the balanced H-network of Fig. 54 are the same as those of the T-network of Fig. 55(a) provided that the total shunt impedance  $z_2$  and the total series impedance  $z_1$  are the same for the two networks, as indicated.

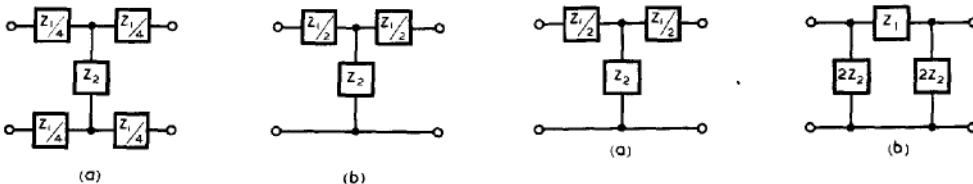

Fig.54. - Balanced and unbalanced networks.

Fig.55. - Symmetrical T- and  $\Pi$ -networks.

Analysis and design are very much simplified if the network can be made symmetrical. This means that if the network is reversed, and its "output terminals" connected to the source and its "input terminals" connected to the load its properties remain the same, whatever the nature of the source or load. The advantage is particularly marked in the case of iterative networks of the types shown in Fig. 56. If many sections are used, with a particular termination, the behaviour of the network as a whole can be described in terms of the change of phase and attenuation due to each section, irrespective of whether the network is split up into T- or  $\pi$ -sections, symmetrical or unsymmetrical. The type that is most simply described, namely the symmetrical section, is thus the most useful to consider and is of sufficiently general application. An unsymmetrical network can always be considered as a symmetrical one with an extra series or shunt component added at the input or output terminals, or both. Symmetrical T- and  $\pi$ -sections are illustrated in Fig. 55.

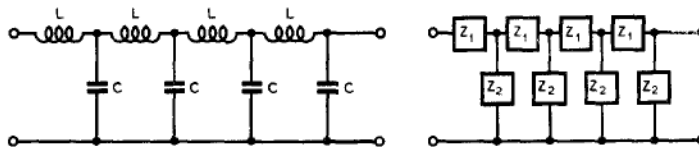

Fig. 56. - Iterative networks.

Some of the properties of unbalanced symmetrical networks will be considered in subsequent sections; only the simplest types will be dealt with in any detail.

2. MEASUREMENT OF INPUT AND OUTPUT IMPEDANCES

In the circuit of Fig. 49(a) the input impedance of the load may be determined by direct measurement of the magnitudes of  $v_L$  and  $i_L$  and their phase relationship. Theoretically, the output impedance of the source is determined by measuring the input impedance between  $S_1$  and  $S_2$  with the generator suppressed (i.e., prevented from generating but without change of its internal impedance.) The remainder of the circuit must be unaltered. From a practical point of view this experiment is one which cannot be performed in the majority of cases: if, through any cause, the actual generator ceases to generate, its internal impedance is almost inevitably altered by this change in the physical conditions. A method which is capable of practical application will now be described.

Suppose that the output impedance of the source is capacitive. A variable load is connected as shown in Fig. 57,  $X_L$  in this case being the reactance of a variable inductance. As the load inductance is varied the magnitude of the alternating voltage  $v_R$  developed across the load

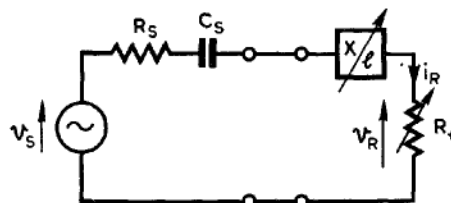

Fig. 57. - Circuit for measuring generator voltage and impedance.

resistance will vary, and will reach a maximum value when the inductive reactance  $X_L = \omega L$  of the load exactly nullifies the capacitive reactance  $- \frac{1}{\omega C_S}$  of the source. A similar method is applicable if the output impedance is inductive.

The resistive component of the output impedance may then be determined by varying the load resistance, and comparing the voltage  $v_R$  developed across it with the current  $i_R$  through it. This variation is shown in Fig. 58. The L-C combination may be considered as a short-circuit as far as  $v_R$  and  $i_R$  are concerned. When sufficient points on the graph have been obtained,  $\hat{v}_S$  and  $\hat{i}_S$ , and hence  $R_S$ , may be determined from the intercepts on the axes, since  $R_S = \frac{\hat{v}_S}{\hat{i}_S}$

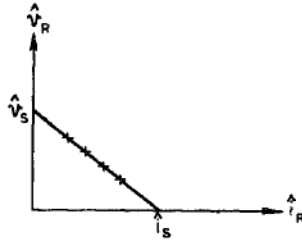

Fig.58.- Determination of output resistance and open-circuit voltage.

Alternatively, the method shown in Fig. 59 may be employed, a similar graph being derived (Fig. 60). It should be noted that  $i_G, v_G, G_\ell, B_\ell$ , are not the same as  $i_R, v_R, \frac{1}{R_\ell}, \frac{1}{X_\ell}$  (See Chap.1, Sec.17)

Practical difficulties arise because, where the generator is an inherent part of the source, changes in load affect its frequency as well as its output voltage and impedance. To reduce these effects to negligible magnitudes, the changes in load impedance should be made very small compared with the total impedance of the circuit.

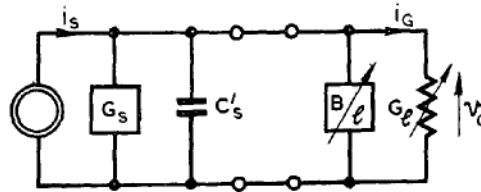

Fig.59.- Circuit for measuring generator current and admittance.

3. SYMMETRICAL T-SECTIONS AND  
II-SECTIONS

Whatever the actual arrangements of the elements forming an unbalanced four-terminal network, it is convenient to describe the behaviour of the network in terms of the equivalent T- or II-network of Fig. 55.

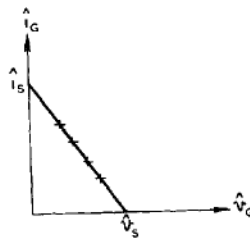

Fig.60.- Determination of output conductance and short-circuit current.

The input impedance  $z_s$  of a symmetrical T-network depends on the manner of its termination  $z_r$  according to the formula :-

$$z_s = \frac{z_1}{2} + \frac{z_2 \left( \frac{z_1}{2} + z_r \right)}{z_2 + \frac{z_1}{2} + z_r}$$

(Fig. 61(a))

It is not always desirable to work in terms of  $z_1$  and  $z_2$ , and three other impedances are frequently used:-

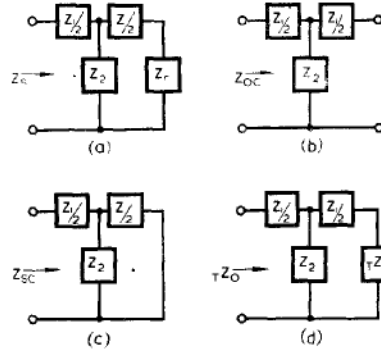

Fig. 61.- Input impedance of T-network for various standard terminations.

(i) Open-circuit impedance:

$z_{oc}$ ; with the output terminals open-circuited,

$${}_T Z_{oc} = \frac{z_1}{2} + z_2 \quad (\text{Fig. 61(b)})$$

(ii) Short-circuit impedance :

$z_{sc}$ ; with the output terminals short-circuited,

$${}_T Z_{sc} = \frac{z_1}{2} + \frac{z_2 \frac{z_1}{2}}{z_2 + \frac{z_1}{2}} \quad (\text{Fig. 61(c)})$$

(iii) Characteristic impedance:

${}_T Z_o$ ; this is a particular impedance such that when the network is terminated in  ${}_T Z_o$  its input impedance is  ${}_T Z_o$ .

$${}_T Z_o = \frac{z_1}{2} + \frac{z_2 \left( \frac{z_1}{2} + {}_T Z_o \right)}{z_2 + \frac{z_1}{2} + {}_T Z_o} \quad (\text{Fig. 61(d)})$$

This equation for  ${}_T Z_o$  reduces to  ${}_T Z_o = \pm \sqrt{z_1 z_2 + \frac{z_1^2}{4}}$

The ambiguity of the  $\pm$  sign is important in the case of reactive impedances, and must be resolved by further consideration of the particular circuit.

$\pi$ -network

Corresponding expressions for the  $\pi$ -network of Fig. 62 are :-

(i) Open-circuit admittance .....

$$y_{oc} = \frac{y_2}{2} + \frac{y_2}{2} \frac{y_1}{\frac{y_2}{2} + y_1}$$

(ii) Short-circuit admittance ....

$$y_{sc} = \frac{y_2}{2} + y_1$$

(iii) Characteristic admittance ...

$$\pi Y_0 = \sqrt{\frac{y_1 y_2 + y_2^2}{4}}$$

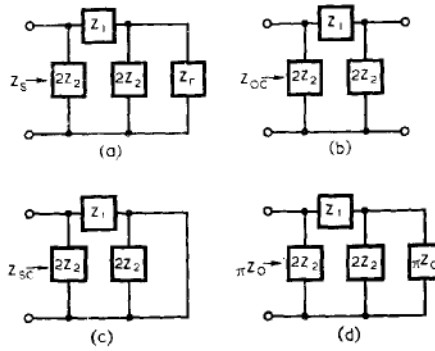

Fig.62.- Input impedances of  $\pi$ -network for various standard terminations.

General

Results frequently useful are :-

$$z_o = \sqrt{z_{sc} z_{oc}}$$

both for T- and  $\pi$ -networks; and

$T z_o = \pi z_o = z_1 \cdot z_2$ , where  $z_1$  and  $z_2$  are the same for both networks.

Propagation constant

When the network is terminated in its characteristic impedance, the ratio between input and output voltages and currents is the same. This ratio is expressed

$$\frac{i_s}{i_r} = \frac{v_s}{v_r} = \epsilon^\gamma$$

where  $\gamma$  is called the Propagation Constant of the network.

In general,  $\gamma$  possesses real and imaginary parts, and is equal to  $\alpha + j\beta$ , where  $\alpha$  corresponds to the attenuation, and  $\beta$  the phase-shift introduced by the properly terminated section.

The magnitude of  $\epsilon^\gamma$  will be denoted by  $k$ , so that  $\alpha = \log_e k$ .

It may be shown that for any symmetrical T- or  $\pi$ -network,  $\gamma$  satisfies the relation

$$\epsilon^\gamma + \epsilon^{-\gamma} = 2 + \frac{z_1}{z_2}$$

4. MATCHING

Consider a transmission system divided into source and load as in Fig. 49. For a given source the load may be designed to satisfy one of many requirements. The three principal requirements are :-

- (i) Maximum current supplied to the load;
- (ii) Maximum voltage applied to the load;
- (iii) Maximum power transferred to the load.

In transmission lines and waveguides a further requirement is the avoidance of reflections and standing waves; this will be dealt with in the appropriate chapters. The load impedances which satisfy the three principal requirements for linear networks are, respectively :-

- (i)  $R_l = 0, X_l = -X_s$ ;
- (ii)  $G_l = 0, B_l = -B_s$ ; (i.e.  $R_l = 0, X_l = -\frac{R_s^2 + X_s^2}{X_s}$  )
- (iii)  $R_l = R_s, X_l = -X_s$ ; or alternatively,  $G_l = G_s, B_l = -B_s$ .

When the conditions (iii) are satisfied, the load and source impedances are said to be conjugate, and the load is said to be matched to the source, and vice versa.

For non-linear networks other criteria must be employed. The power delivered to the load, for instance, may be plotted against the load reactance, and a series of curves obtained for different values of load resistance. The optimum values of  $R_l$  and  $X_l$  are obtained as shown in Fig. 63. Where the regulation of the source with changes in loading is an important consideration, it may be desirable not to choose the load input impedance for maximum power, but to take the stability into account (E.g. Chap. 8 Sec. 40).

If source and load are not variable, and the ideal matching conditions not realised, a matching section may be inserted in the line between source and load. Ideally, this will consist of reactive elements, designed to provide maximum power transfer from source to load without itself absorbing energy. (Since the input impedance of the load is fixed, the conditions for maximum power also ensure that both maximum voltage and current are delivered to the load). The output impedance of the network, fed by the source, will be the conjugate of  $z_l$ , whilst the input impedance of the network, terminated in  $z_l$ , will be the conjugate of  $z_s$ , as indicated in Fig. 64. In general it will not be possible to satisfy these conditions exactly except at one or two frequencies, although approximate matching may be obtained over a band of frequencies.

For resistive impedances at audio frequencies an iron-cored transformer is a suitable matching device. This has the advantage that its matching properties for low frequencies are reasonably independent of frequency, and depend only on the ratio of  $R_s$  to  $R_l$ . For use at higher frequencies various types of matching sections are used, all suffering more or less from the disadvantage of being sensitive to frequency changes. Some of these are described in Chaps. 4 and 5.

### 5. GAIN AND LOSS

In general the network of Fig. 50 will involve either amplification or attenuation of the input voltage, current and power. If the

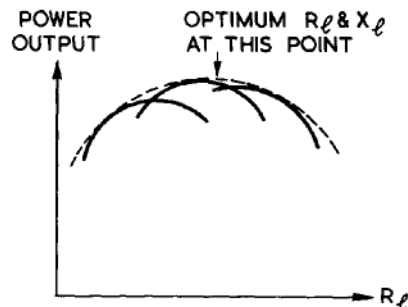

Fig. 63.- Method of determining correct matching conditions when system is not linear.

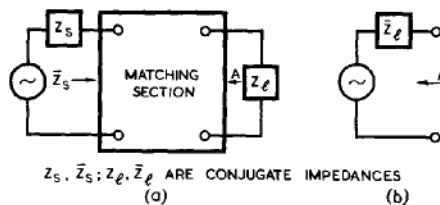

Fig. 64.- Use of matching section.

magnitude of the sinusoidal input voltage is  $\hat{v}_i$  and of the output voltage  $\hat{v}_o$ , then  $\hat{v}_o/\hat{v}_i$  is the voltage amplification of the network. Similarly  $\frac{\hat{i}_o}{\hat{i}_i}$  and  $\frac{P_o}{P_i}$  are the current and power amplifications.

It is customary to define quantities known as "Gains and Losses" in terms of the logarithms of these ratios.

**Power ratio** The Power Gain is defined as

$$g_p = \log_{10} \frac{P_o}{P_i} \text{ bels}$$

$$= 10 \log_{10} \frac{P_o}{P_i} \text{ decibels (db.)}$$

**Voltage ratio**

The Voltage Gain is defined as

$$g_v = \log_{\xi} \frac{\hat{v}_o}{\hat{v}_i} \text{ nepers}$$

**Current ratio** The Current Gain is defined as  $g_i = \log_{\xi} \hat{i}_o/\hat{i}_i$  nepers.

Other terms are also used. Thus, voltage and current gains are commonly quoted in decibels. The appropriate definitions are :-

$$g_v = 20 \log_{10} \frac{\hat{v}_o}{\hat{v}_i} \text{ decibels}$$

$$g_i = 20 \log_{10} \frac{\hat{i}_o}{\hat{i}_i} \text{ decibels}$$

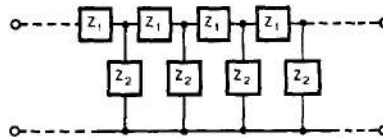

Fig.65. - Iterative networks.

These definitions imply that if the input and load impedances are identical the voltage, current and power gains give the same numerical value in decibels.

Similarly the power gain may be quoted in nepers, in which case

$$g_p = \frac{1}{2} \log_{\xi} \frac{P_o}{P_i} \text{ nepers}$$

These equivalences can be summarised by the statements

$$1 \text{ neper} = 8.69 \text{ decibels}$$

or  $1 \text{ decibel} = 0.115 \text{ nepers.}$

Where attenuation instead of amplification occurs the corresponding formula for the decibel or neper loss may be obtained from the above by interchanging the subscripts i and o.

e.g. the voltage loss is  $20 \log_{10} \frac{\hat{v}_i}{\hat{v}_o}$  decibels

## 6. ITERATIVE SECTIONS

Four-terminal networks are frequently used in Cascade (or Tandem) to form a line. Such a line is shown in Fig. 65 and may be called an Artificial Line, as distinct from a uniform transmission line which it

may be desired to simulate. It may be considered as an iterative sequence of either T- or  $\pi$ -sections, according to the mode of termination, as illustrated in Fig. 66. In the mechanical construction of the complete network no distinction is made between T- and  $\pi$ -sections except at the output and input terminals. Since it is usual to match the input to the source by a matching section, it is convenient to consider the output termination only as determining the manner in which the line is divided into its constituent networks for purposes of analysis. Thus the network of Fig. 67(a) may be split into two parts, as in Fig. 67(b), the iterative portion terminated in its characteristic impedance  $\pi Z_0$ , and the non-iterative portion at the input, each part being considered separately.

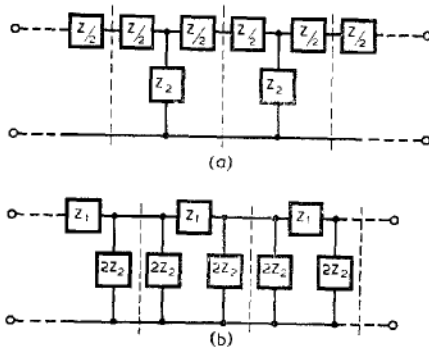

Fig. 66.- Dividing an iterative network into symmetrical T- and  $\pi$ -sections.

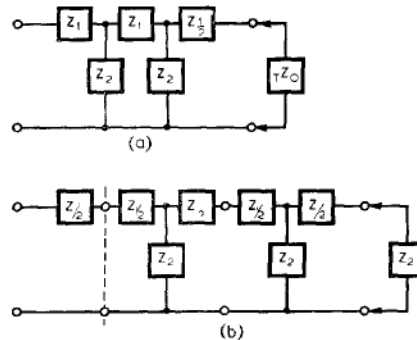

Fig. 67.- Dissection of network for purposes of analysis.

If an artificial line is terminated in its characteristic impedance appropriate to the mode of division, it exhibits the input properties of an infinite artificial line, since any number of sections may be inserted between the output terminals and the load without interfering with the input conditions. It follows that although the characteristic impedance depends on the mode of termination and division, the propagation constant of a single section is the same provided the artificial line is properly terminated. For example, in the network of Fig. 68 the attenuation and phase shift per section are characteristic of the infinite artificial line (b) and are therefore the same for the iterative T-network of (a) as for the equivalent  $\pi$ -network of (d).

( The Sign  $\equiv$  used in this and other diagrams signifies that corresponding voltage and currents in the various networks are the same )

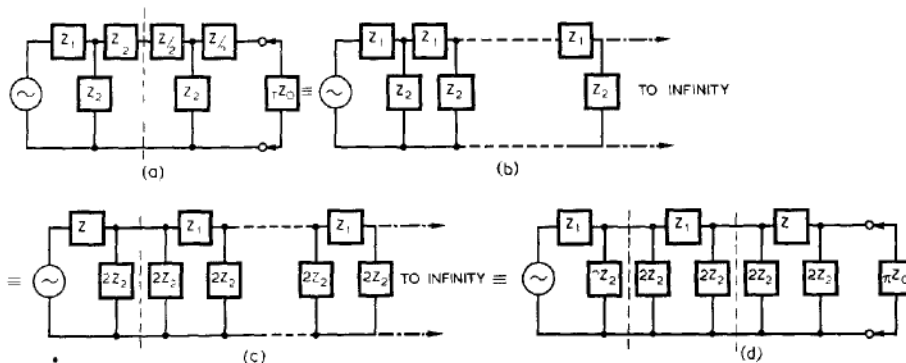

Fig. 68.- Alternative representations of a properly matched iterative network.

Iterative networks are commonly used as attenuators, filters or delay networks, and the particular properties of these will be described in subsequent sections.

7. ATTENUATORS

An attenuator is required to yield without distortion at its output terminals a predetermined fraction of the input power or voltage.

For an ideal attenuator  $\gamma$ , the propagation constant, is real, so that  $\beta = 0$  (See Sec. 3); also the characteristic impedance is independent of frequency. To meet the requirements with the symmetrical networks described above,  $z_1$  and  $z_2$  must be the same kind of impedance (i.e. the phase angles must be the same), and should be chosen to suit the load. Since the load is normally resistive,  $z_1$  and  $z_2$  are usually resistances, and, particularly when the attenuator is used for high frequency measurements, special care must be taken to avoid stray reactance. Under certain circumstances, such as for attenuating a large alternating voltage to apply to the deflector plates of a CRT a capacitive attenuator may be used; whilst for monitoring RF waveforms without extracting power, inductive attenuators may be preferable. Only the resistive type will be considered here; the formulae for these are given below. The corresponding formulae for the cases where  $z_1$  and  $z_2$  are pure reactances of like kind may be obtained by substituting  $X$  for  $R$  throughout.

Properties of a symmetrical resistive attenuator network

For a network of given type, determined by  $R_1$  and  $R_2$  and divided into symmetrical sections as shown in Fig. 69,

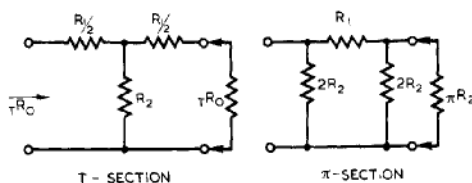

Fig.69.- Matched attenuators.

$$T R_o = \frac{\sqrt{R_1 R_2 + \frac{R_1^2}{4}}}{4}, \quad \pi G_o = \frac{\sqrt{G_1 G_2 + \frac{G_2^2}{4}}}{4}$$

(Note:  $\pi G_o = \frac{1}{T R_o}$ ,  $G_1 = \frac{1}{R_1}$

and  $G_2 = \frac{1}{R_2}$  )

and  $T R_o \cdot \pi R_o = R_1 \cdot R_2$

Putting  $\beta = 0$  in the formula for  $\gamma$  given in Sec. 3, and writing  $\xi^\gamma = \xi^\alpha = k$ , we have

$$k + \frac{1}{k} = 2 + \frac{R_1}{R_2}$$

Chap. 3, Sect. 7

The following useful formulae may be deduced :-

$$k = \frac{R_1 + 2\pi R_0}{R_1 - 2\pi R_0} = \frac{\pi R_0 + 2R_2}{\pi R_0 - 2R_2} ;$$

$$R_1 = 2 \cdot \frac{k-1}{k+1} \cdot \pi R_0 \quad \text{and} \quad R_2 = \frac{2k}{k^2-1} \pi R_0 ;$$

$$R_1 = \frac{k^2-1}{2k} \pi R_0 \quad \text{and} \quad R_2 = \frac{1}{2} \cdot \frac{k+1}{k-1} \cdot \pi R_0.$$

These formulae enable  $\pi R_0$  or  $\pi R_0$  and  $k$  to be determined from  $R_1$  and  $R_2$ , or vice versa.

The attenuation in db per section is  $20 \log_{10} k$ .

Examples

(1) Construct a T-section attenuator to provide 14 db loss per section and to match to a 2000 ohms line.

$$\text{We have } 20 \log_{10} k = 14.$$

$$\text{Hence } k = 5$$

$$\text{Also } \pi R_0 = 2000$$

$$\text{Hence } R_1 = 2 \left( \frac{k-1}{k+1} \right) \pi R_0$$

$$= 2 \cdot \frac{4}{6} \cdot 2000$$

$$\approx 2670 \text{ ohms}$$

$$\text{Also } R_2 = \frac{2k}{k^2-1} \pi R_0$$

$$= \frac{10}{24} \cdot 2000$$

$$\approx 830 \text{ ohms}$$

Hence each section is formed of two series resistances, each 1335 ohms and a shunt resistance 830 ohms.

(2) A  $\pi$ -section attenuator has shunt resistances 4000 ohms and series resistance 1000 ohms. To find the characteristic resistance and db loss per section.

$$\text{We have } R_1 = 1000 \Omega. \quad R_2 = 2000 \Omega.$$

$$\text{Hence } \pi G_0 = \sqrt{1 \cdot \frac{1}{2} + \left(\frac{1}{2}\right)^2 \cdot \frac{1}{4}} \text{ millimhos.}$$

$$= \sqrt{\frac{9}{16}} \text{ millimhos.}$$

$$\text{i.e. } R_0 = \frac{4}{3} \text{ k ohms}$$

$$\dot{=} 1330 \text{ ohms .}$$

$$\begin{aligned} \text{Also } k + \frac{1}{k} &= 2 + \frac{R_1}{R_2} \\ &= 2 + \frac{1}{2} \end{aligned}$$

Hence  $k = 2$  and the db. loss per section is 6.

FILTERS

8. Ideal Requirements

The ideal requirements for a filter network are illustrated in Fig. 70. The frequency spectrum is divided into pass bands and attenuation bands. In the former, no attenuation is desired, and any unavoidable phase shift should be proportional to frequency. Outside the pass bands there should be infinite attenuation of signals at all frequencies.

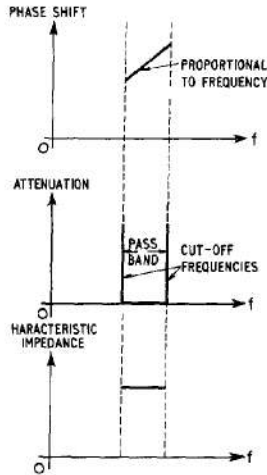

Fig.70.- Ideal characteristics for a filter.

Since the load is normally resistive, the characteristic impedance in the pass band should be a resistance of constant value.

In practice it is impossible to make the phase shift proportional to frequency over the whole of the pass band, and the transition from pass band to attenuation band at the Cut-Off Frequency, as the bordering frequency is called, involves a more or less gradual increase in attenuation as the frequency recedes from its cut-off value.

9. Simple High-Pass and Low-Pass Filters

In the ideal networks about to be described it is assumed that reactive elements are devoid of resistance. The results obtained in

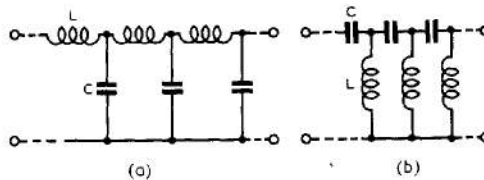

Fig.71.- Simple filter networks.

practice agree closely with those derived from this assumption provided high-Q components are used.

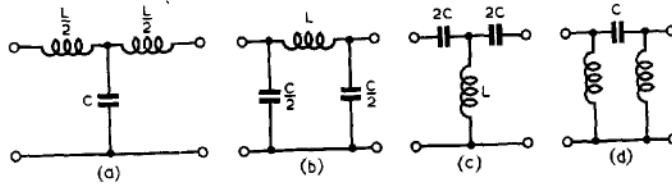

Fig. 72. - Symmetrical T-section and  $\pi$ -section filter networks.

To provide frequency discrimination without attenuation, both capacitive and inductive reactances must be used. The simplest, or prototype, filters are shown in Fig. 71, and the symmetrical T- and  $\pi$ -section arrangements in Fig. 72. For certain filter applications the resistance-capacitance networks of Fig. 73 may be used. In these the usual object is to make the capacitive impedances sufficiently low compared with the resistance, at all frequencies likely to be present.

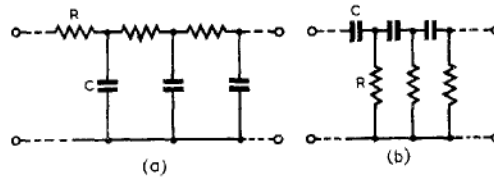

Fig. 73. - R-C filters.

10. Simple Low-Pass Filter Formed of Purely Reactive Elements

Fig. 74(a) represents an iterative network of any number of identical sections formed of perfect coils and condensers; the network is properly terminated so that, at the input terminals PO, it looks like an infinite line.

The letters Q, S, U, denote the meshes of the networks, and the currents,  $i_Q, i_S$  etc. the corresponding series currents.  $v_Q$  and  $v_S$  etc. are the voltages developed across the series impedances.

The subscript m denotes the electrical centre of a series reactance (e.g.  $Q_m$  is the electrical centre of PR) or the space which divides a shunt susceptance into two equal

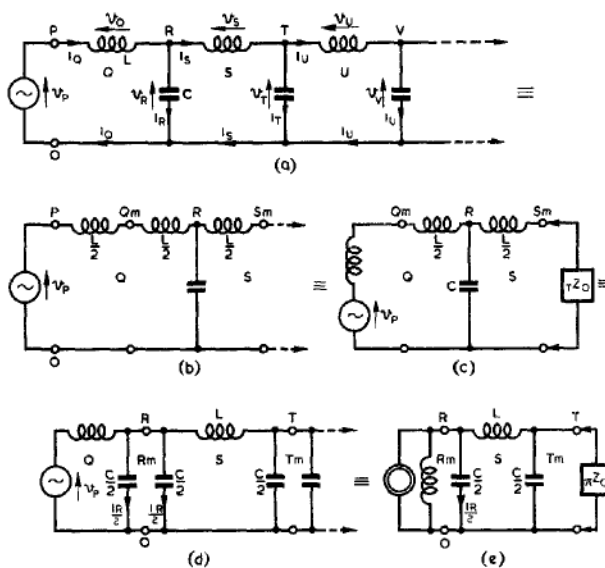

Fig. 74. - Alternative representations of a properly matched iterative network.

susceptances (e.g.  $R_m$  divides  $\omega C$  into two susceptances each  $\frac{\omega C}{2}$ )

The sign  $\equiv$  implies that those portions of the various figures which are similarly lettered carry identical currents and voltages.

In the associated diagrams of Figs. 75 - 77 OP, OR etc. denote the voltages between the corresponding points of Fig. 74, whilst OQ, OS etc. denote the currents in the corresponding branches.

As shown in Section 6, the phase-shift,  $\beta$  radians, and attenuation constant  $k$ , for each section, are independent of the manner in which the network is divided into T- or  $\pi$ - sections. To consider the properties of the symmetrical T- network of this type of filter, the line is divided at the middle of one of the series inductances, as shown in Fig. 74(b), where the inductance  $L$  between P and R is bisected at  $Q_m$ . For a symmetrical  $\pi$ -section each of the shunt capacitances is split into two equal parts as shown in Fig. 74(d), so that the line appears as in Fig. 74(e). For either method of division there is no change in any of the voltages or currents to the right of the chosen input terminals.

The properties of the low-pass filter will be derived by considering the geometry of the vector diagrams. The data upon which these diagrams are based are :-

- (i) The phase shift  $\beta$  radians per section;

i.e.,  $v_S$  lags  $v_Q$ ,  $v_T$  lags  $v_R$ ,  $v_U$  lags  $v_S$  etc., all by  $\beta$  radians.

- (ii) The attenuation  $k$  per section; i.e.,

$$k = \frac{\hat{v}_P}{\hat{v}_R} = \frac{\hat{v}_R}{\hat{v}_Q} = \dots = \frac{\hat{v}_Q}{\hat{v}_S} = \frac{\hat{v}_S}{\hat{v}_U} \dots = \frac{\hat{i}_Q}{\hat{i}_S} = \frac{\hat{i}_S}{\hat{i}_U} \dots \text{etc}$$

where  $\hat{v}_P$ , etc., are the amplitudes of the alternating voltages and currents.

- (iii) The voltage vector leads the current vector by  $\frac{\pi}{2}$  radians for an inductance, and lags by  $\frac{\pi}{2}$  radians for a capacitance.

There are two types of vector diagram consistent with these relationships, relating to the pass band and attenuation band respectively.

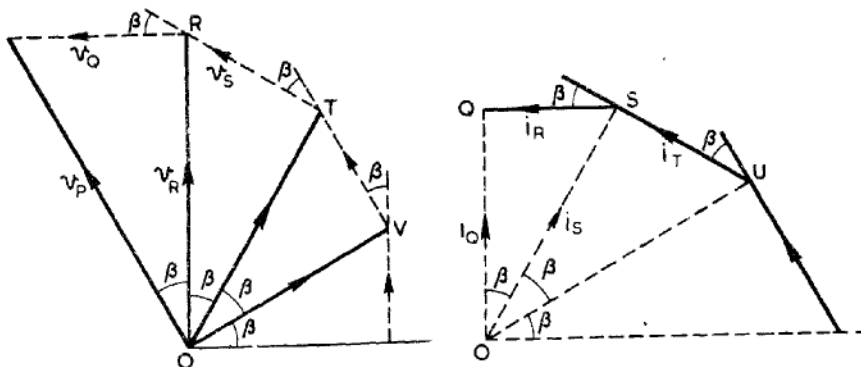

Fig. 75.- Vector diagram.

Pass Band

The relationships (i) and (iii) above are plausibly illustrated in the vector diagrams of Fig. 75. It will now be shown that (ii) implies that

$$OP = OR = OT, \text{ etc and } OQ = OS = OU, \text{ etc.}$$

Since PR is perpendicular to OQ (voltage and current vectors for coil PR) and RO is perpendicular to QS (voltage and current vectors for condenser RO).

$$\triangle PRO = \triangle SQO.$$

Hence the triangles PRO, SQO and, similarly, all the other triangles, are equiangular, so that their corresponding sides are proportional.

Therefore

$$\begin{aligned} \frac{PO}{RO} &= \frac{SO}{QO} \\ \text{i.e. } \frac{\hat{v}_P}{\hat{v}_R} &= \frac{SO}{QO} \dots\dots\dots(1) \\ \text{But } \frac{\hat{v}_P}{\hat{v}_R} &= \frac{\hat{i}_L}{\hat{i}_C} = \frac{QC}{SO} = k \text{ from (ii)} \end{aligned}$$

$$\text{hence } \frac{QC}{SO} = \frac{SO}{QO}; \text{ i.e. } SO = QO \text{ and } k = 1$$

hence there is no attenuation in the pass band.

Fig. 76 shows the true vector diagrams superimposed, with these relationships satisfied.

Referring to this figure

$$\sin \frac{\beta}{2} = \frac{\frac{1}{2} \hat{i}_R}{\hat{i}_Q} = \frac{\frac{1}{2} \hat{v}_Q}{\hat{v}_R} = \sqrt{\frac{\hat{i}_R \hat{v}_Q}{4 \hat{i}_Q \hat{v}_R}} ;$$

$$\text{but } \frac{\hat{v}_Q}{\hat{i}_Q} = \omega L, \text{ and } \frac{\hat{v}_R}{\hat{i}_R} = \frac{1}{\omega C} ;$$

$$\text{hence } \sin \frac{\beta}{2} = \sqrt{\frac{\omega^2 LC}{4}} = \sqrt{\frac{\omega^2}{\omega_0^2}} = \frac{f}{f_0} ,$$

$$\text{where } \omega = 2\pi f \text{ and } \omega_0 = 2\pi f_0 = \sqrt{\frac{4}{LC}} ;$$

$$\text{i.e. } f_0 = \frac{1}{\pi \sqrt{LC}} \text{ (which will later be known as the cut-off frequency)}$$

It follows that, as drawn, the vector diagram is valid for only one value of  $f_1$ , and that similar diagrams can be drawn only for values of  $f \leq f_0$ , since  $\sin \frac{\beta}{2}$  cannot be greater than 1.

$f_c$  is called the Cut-Off Frequency.

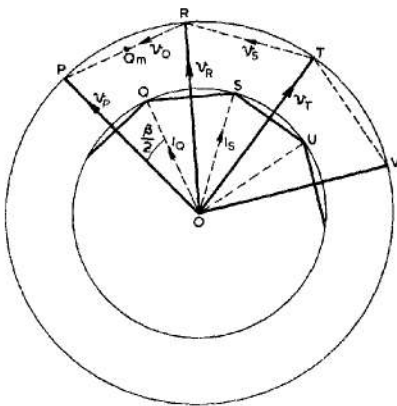

Fig. 76. - Pass-band vector diagram for low-pass filter.

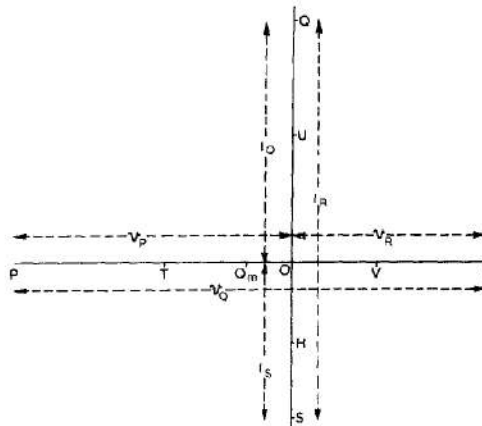

Fig. 77. - Attenuation band vector diagram for a low-pass filter.

Characteristic Impedance

The T-section characteristic impedance is the ratio of the potential difference, between  $Q_m$  and O to the current  $i_Q$  (Fig. 74(c)).

This is the ratio  $\frac{Q_m O}{QO}$  (Fig. 76).

$$\begin{aligned} \text{Thus } T^{ZO} &= \frac{Q_m O}{QO} = \frac{Q_m O}{RO} \cdot \frac{RO}{QO} \\ &= \cos \frac{\beta}{2} \cdot \frac{\hat{V}_R}{\hat{i}_Q} \end{aligned}$$

But, in the triangles PRO, QSO,

$$\frac{\hat{V}_Q}{\hat{i}_R} = \frac{\hat{V}_R}{\hat{i}_Q} = \sqrt{\frac{\hat{V}_R \cdot \hat{Q}}{\hat{i}_R \cdot \hat{i}_Q}} = \sqrt{\frac{\omega L}{\omega C}} = \sqrt{\frac{L}{C}}$$

$$\text{Hence } T^{ZO} = \sqrt{\frac{L}{C}} \cos \frac{\beta}{2}$$

Also  $Q_m O$  and  $QO$  are collinear, showing that the impedance is purely resistive. (Similarly, from  $R_m O$  and  $RO$ , corresponding to the  $\pi$ -division of Fig. 74(e), it may be shown that  $\pi^{ZO} = \sqrt{\frac{L}{C}} \sec \frac{\beta}{2}$ , and is purely resistive).

Attenuation Band

At frequencies higher than the cut-off frequency, the phase-shift  $\beta$  remains at its cut-off value,  $\pi$  radians per section. The vector diagrams collapse into single lines, as shown in Fig. 77, so that equation (1) in the analysis of the pass band no longer holds. All the currents are in quadrature with the corresponding voltages, and the characteristic impedance for the T-section is an inductive reactance.

Attenuation per section

Referring to Fig. 77

$$\begin{aligned} \hat{i}_R &= \hat{i}_Q + \hat{i}_S = (k+1) \hat{i}_S; \\ \hat{v}_Q &= \hat{v}_P + \hat{v}_R = (k+1) \hat{v}_R \dots\dots\dots(2) \end{aligned}$$

Hence

$$\frac{\hat{v}_Q}{(k+1) \hat{i}_S} = \frac{(k+1) \hat{v}_R}{\hat{i}_R}$$

i.e.  $\frac{k \hat{v}_S}{(k+1) \hat{i}_S} = \frac{(k+1) \hat{v}_R}{\hat{i}_R}$

Therefore  $\frac{k \omega L}{k+1} = \frac{k+1}{\omega C}$ ; i.e.  $\frac{(k+1)^2}{k} = \omega^2 LC = \frac{4\omega^2}{\omega_c^2}$

Hence  $\frac{k+1}{\sqrt{k}} = \frac{2\omega}{\omega_c}$

or  $\sqrt{k} + \frac{1}{\sqrt{k}} = \frac{2f}{f_c}$

From this it may be deduced that the attenuation per section is given by:-

$$\sqrt{k} = \frac{f}{f_c} + \sqrt{\left(\frac{f}{f_c}\right)^2 - 1}$$

(The propagation constant,  $\gamma$ , is  $\alpha + j\beta$ , where  $\beta = \pi$  and  $\alpha = \log_e k$  nepers per section).

Characteristic Impedance

In the attenuation band

$$\begin{aligned} T_{XO} &= \frac{Q_{m0}}{Q_0} \\ &= \frac{\hat{v}_P - \hat{v}_R}{2\hat{i}_Q} \\ &= \frac{\hat{v}_R (k-1)}{2\hat{i}_Q} \\ &= \frac{\hat{v}_Q (k-1)}{(k+1) 2\hat{i}_Q} \dots\dots\dots \text{from (2) above} \\ &= \frac{\omega L}{2} \cdot \frac{(k-1)}{(k+1)} \\ &\doteq \frac{\omega L}{2} \quad \text{for } k \text{ large;} \end{aligned}$$

i.e. for  $f \gg f_c$ .

This gives the magnitude of the characteristic impedance.

The above results may be obtained more readily by the use of the theory of complex numbers, applied to the formulae given in Section 3.

11. Graphical Representation of Properties of a Simple Low-Pass Filter T-Section

For a network containing the ideal components of Fig. 74(a) the characteristic impedance and attenuation vary with frequency as shown in Fig. 78. These variations are obtained from the formulae derived above.

It is common practice to draw the Loss-Frequency curve, instead of the attenuation frequency curve. The loss may be plotted on an inverted axis, as shown in Fig. 78(c), and is  $20 \log_{10} k$  decibels per section.

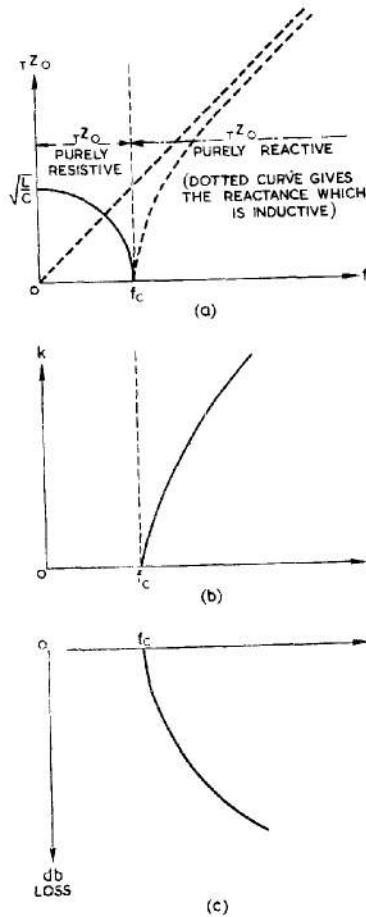

Fig. 78.- Characteristic properties of a low-pass filter (T-section).

Effect of incorrect termination

It is not generally possible to terminate such a network by its characteristic impedance at all frequencies, because of the inconvenient form of the variations which occur in this quantity with changes of frequency. In practice, the simplest compromise available is to make the load a resistance of value  $\sqrt{\frac{L}{C}}$ . The filter is

then properly terminated at zero frequency, and the effect of incorrect termination is not pronounced until cut-off frequency is approached, particularly if the output impedance of the source is also a resistance of value

$\sqrt{\frac{L}{C}}$ . The effect is illustrated in Fig. 79, where the loss-frequency characteristic is plotted for a single T-network terminated in  $\sqrt{\frac{L}{C}}$ .

The input impedance is not purely resistive except at zero frequency, and some loss (3 db. at  $f_c$ ) is introduced into the pass band. If several sections are used in cascade, terminated in  $\sqrt{\frac{L}{C}}$ , or if a matching

section is inserted between the T-network and the load, the loss-frequency characteristic for each section will lie generally between the two curves of Fig. 79.

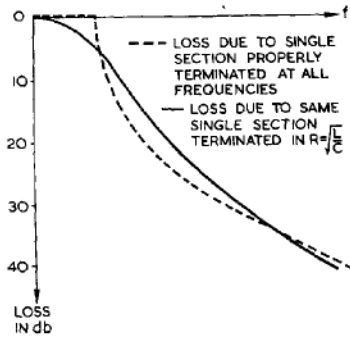

Fig. 79.- Loss for single low-pass filter section terminated in  $\sqrt{L/C}$  at all frequencies.

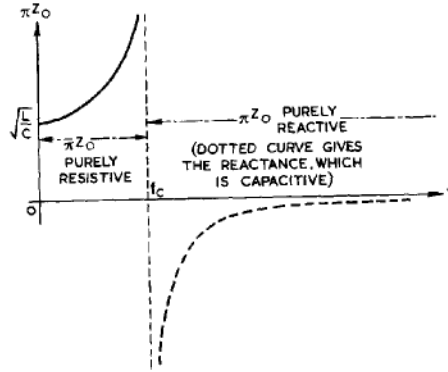

Fig. 80.- Characteristic impedance of a low-pass filter.

12. Properties of Simple Low-Pass Filter  $\pi$  -sections

The attenuation due to a filter formed of  $\pi$  -sections is the same as for the corresponding T-section network, as described in Sec. 6. The principal difference between the two types lies in their characteristic impedances, that of the  $\pi$  -section becoming infinite at the cut-off frequency, and becoming a capacitive reactance in the attenuation band (Fig. 80).

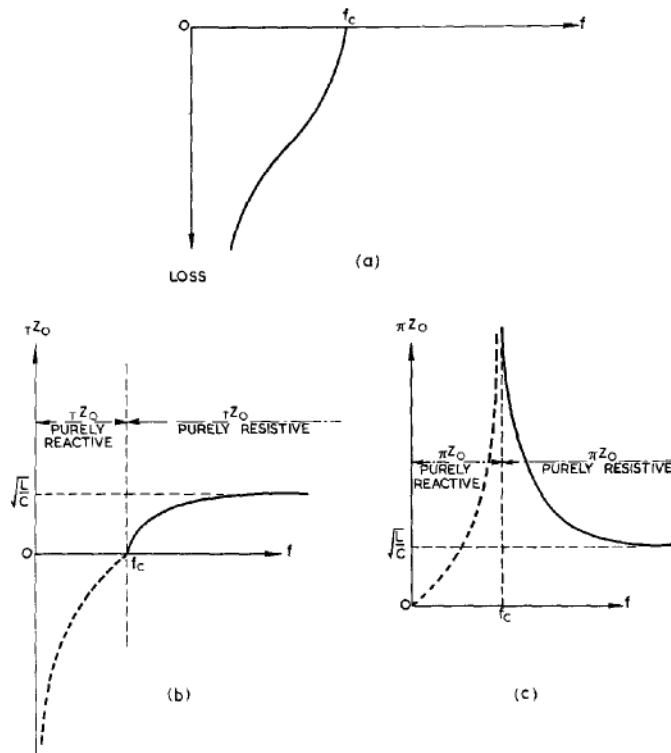

Fig. 81.- Loss and characteristic impedance curves for a simple high-pass filter.

The two characteristic impedances are related by the formula

$$\pi z_0 \cdot \pi z_0 = z_1 \cdot z_2 = \frac{L}{C}$$

13. Properties of Simple High-Pass, Band-Pass and Band-stop Filters

The loss curves and characteristic impedances of the simple high-pass filters of Fig. 72(c) and (d) are shown in Fig. 81

A band-pass filter may be formed of a high-pass and a low-pass filter in cascade. Idealised loss curves for such a filter are shown in Fig. 82, but these are not attainable in practice due to unavoidable resistive losses and also to the impossibility of terminating both filters correctly at all frequencies within the pass band.

Similarly a band-stop filter may be formed by bridging a high-pass and low-pass filter, as shown in Fig. 83.

The types of band-pass and band-stop filters commonly met with in radio receivers are simpler in that they involve fewer components than are required by the bridge or cascade connections just described, but the analysis and design are more complicated and the attenuation-frequency characteristics are usually much inferior to the idealised curves of Figs. 82 and 83. For RF and IF circuits of a radio receiver such filters are generally made adjustable, and the final sizes of components chosen empirically.

14. Other Types of Filters

Networks more complicated than those described above are frequently used as filters. Some arrangements are shown in Figs. 84 to 87, with ideal attenuation characteristics. These are examples of "m-derived" sections, and reference should be made to more advanced texts for a discussion of their properties. The provision of a parallel anti-resonant circuit in the series arm, or a series resonant circuit in the shunt arm introduces infinite attenuation at the resonant frequency of the tuned circuit.

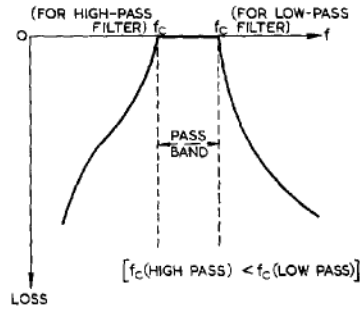

Fig.82.- Loss for band-pass filter formed by high-pass and low-pass filters in cascade.

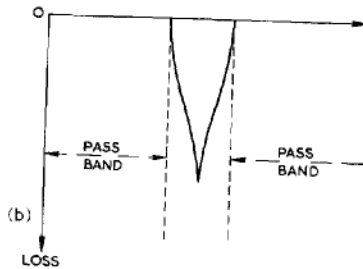
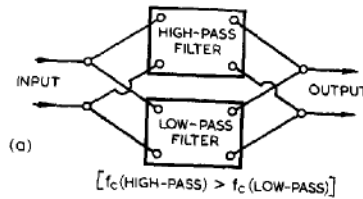

Fig.83.- Band-stop filter formed by bridging high-pass and low-pass filter.

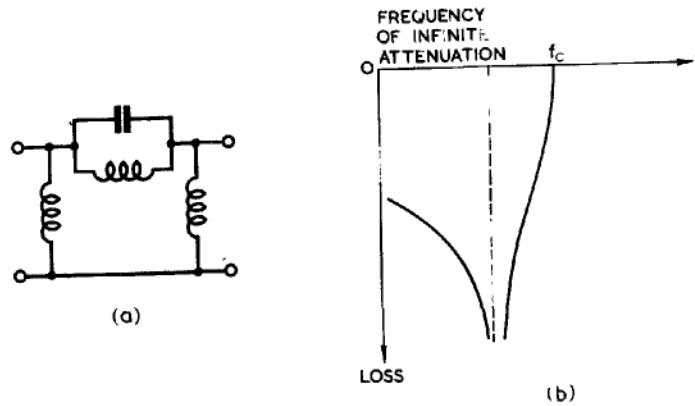

Fig. 84.- High-pass m-derived  $\pi$ -section filter.

In practice, resistive losses modify the idealised curves, introducing a certain amount of attenuation in the pass-band, and generally decreasing the sharpness of the distinction between pass and attenuation bands. High-Q circuits and components are required if the ideal curves are to be approached closely; for this reason piezo-electric crystals are frequently used in place of tuned circuits in band-stop and band-pass filters, but the use of these is limited by their very narrow tuning range.

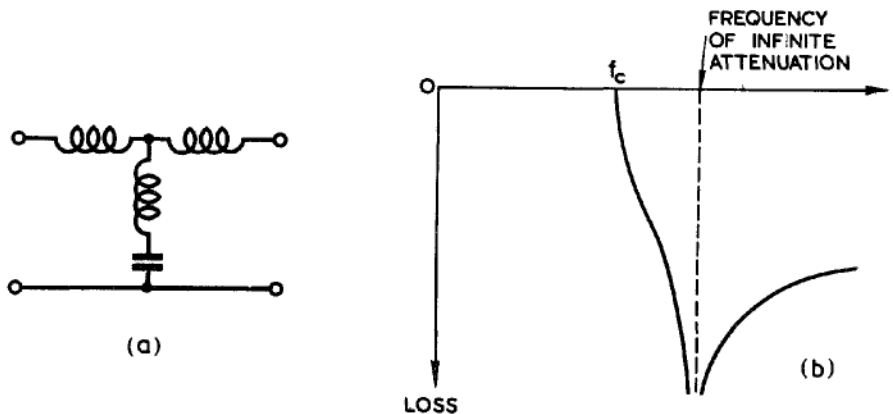

Fig. 85.- Low-pass m-derived T-section filter.

15. Delay Networks

It is shown in Chap. 4. Sec. 6 how the change of phase produced in a transmission line depends on the time taken for an electromagnetic wave to pass along the line. The same is true for an artificial line or Delay Network. If this time of transit is  $T$ , then the phase angle  $\phi$ , by which the output lags the input, is connected with  $T$  and  $f$ , the frequency, by the relation

$$\phi = 2\pi fT$$

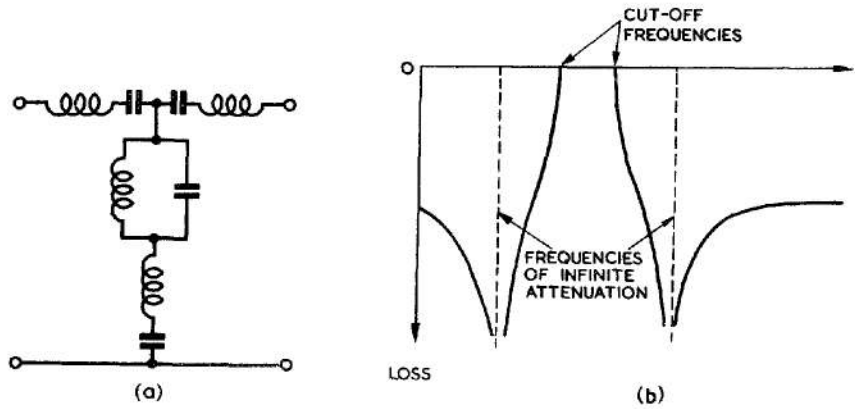

Fig. 86. - Band-pass  $m$ -derived T-section filter.

For a simple low-pass network of  $n$  sections properly terminated, the time of transit for a wave of frequency  $f \ll f_c$  may be taken as

$$T = \frac{\theta}{2\pi f} = \frac{n\beta}{2\pi f}, \quad \text{where } \sin \frac{\beta}{2} = \frac{f}{f_c} = \pi f \sqrt{LC}.$$

Hence, for  $f \ll f_c$ , when  $\sin \frac{\beta}{2} \doteq \frac{\beta}{2}$ ,

$$T \doteq \frac{n}{2\pi f} \cdot 2\pi f \sqrt{LC}$$

$$\doteq n \sqrt{LC}. \quad (\text{This result is independent of } f, \text{ provided } f \ll f_c.)$$

For higher values of  $f$  (but still within the pass-band), the value of  $T$  increases, until at  $f = f_c$  the time of transit is  $T = \frac{n\pi}{2\pi f_c}$

$$= \frac{n}{2f_c} = \frac{n\pi}{2} \cdot \sqrt{LC}. \quad \text{The variation of } \beta \text{ and } T \text{ with frequency}$$

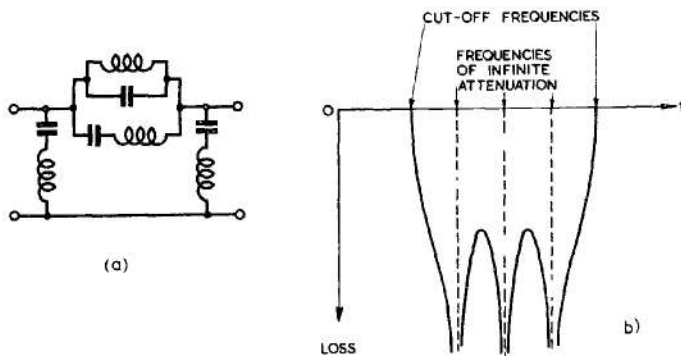

Fig. 87. - Band-stop  $m$ -derived  $\pi$ -section filter.

is illustrated in Fig. 88.

This increase in time-delay with rising frequency causes distortion of non-sinusoidal waves, this distortion being superimposed on that due to the attenuation of components whose frequency is higher than the cut-off frequency. Where such a network is used to delay a rectangular pulse the cut-off frequency should be high compared with  $\frac{1}{T_p}$ , where  $T_p$  is the pulse width. This determines the maximum permissible value of  $\sqrt{LC}$ , so that the number of sections necessary may be determined from the formula:-

$$n = \frac{T}{\sqrt{LC}}, \quad T \text{ being the total delay required.}$$

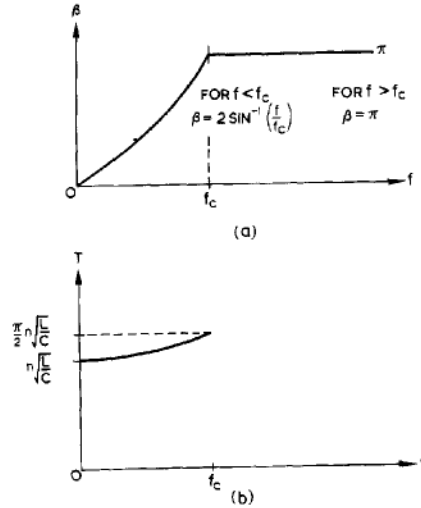

Fig.88.- Variation of phase shift and delay time with frequency.

The actual values of L and C needed are determined from the chosen cut-off frequency and the value  $R_\ell$  of the resistive termination of the network. Thus :-

$$f_c = \frac{1}{\pi \sqrt{LC}} \quad \text{and} \quad R_\ell = \sqrt{\frac{L}{C}},$$

$$\text{whence } C = \frac{1}{\pi f_c R_\ell} \text{ farads, and } L = \frac{R_\ell}{\pi f_c} \text{ henries,}$$

$R_\ell$  being measured in ohms and  $f_c$  in c/s.

**16. Use of Delay Line for Producing Rectangular Pulses**

It is shown in Chap. 4, Sec. 12 that a length of transmission line may be used to produce narrow, rectangular pulses. The advantage of using a uniform cable for such purposes is that it passes all waveforms without distortion. As described in Chap. 4, the pulse is produced by a wave travelling to the end of the cable and back again, so that the cable delay time must be half the desired pulse width.

An artificial line formed of from two to eight low-pass filter sections may be used in place of the cable, with considerable saving of both space and weight.

Since  $T = \frac{1}{2} T_p$ , the design requirements for the network given in Sec. 15 include the relations

$$\frac{1}{\pi \sqrt{LC}} \gg \frac{1}{T_p} \quad \text{and} \quad \frac{1}{2} T_p = n \cdot \sqrt{LC}$$

so that 
$$\frac{1}{\pi \sqrt{LC}} \gg \frac{1}{2 n \sqrt{LC}}$$

$$\text{or } n \gg \frac{\pi}{2} .$$

For values of  $n$  greater than 6, or thereabouts, the pulse can be made substantially rectangular.

Examples

- (i) To construct a low-pass filter T-section whose characteristic impedance at zero frequency is 600 ohms and whose cut-off frequency is 4 Mc/s.

$$\text{We have } \sqrt{\frac{L}{C}} = 600 \quad \text{and} \quad \frac{1}{\pi\sqrt{LC}} = 4 \cdot 10^6$$

$$\text{Hence } \sqrt{LC} = \frac{1}{4\pi \cdot 10^6}$$

$$\begin{aligned} \therefore L &= \frac{600}{4\pi \cdot 10^6} \\ &= \frac{150}{\pi} \text{ microhenries} \\ &\doteq 47.7 \text{ microhenries.} \end{aligned}$$

$$\begin{aligned} \text{Similarly } C &= \frac{1}{4\pi \cdot 10^6} \cdot \frac{1}{600} \\ &= \frac{1}{24\pi \cdot 10^8} \\ &\doteq 133 \text{ pF.} \end{aligned}$$

Hence the T-section has two series inductances each of 24 microhenries and a shunt capacitance of 133 pF.

- (ii) To construct a delay line to pass signals of all frequencies up to 3 Mc/s and to provide a total delay of 6  $\mu$ s. It must match a 2000 ohm line.

$$\text{We make } f_c = \frac{1}{\pi\sqrt{LC}} = 3 \cdot 10^6 \text{ and } \sqrt{\frac{L}{C}} = 2000.$$

As for the previous example we obtain

$$\sqrt{LC} = \frac{1}{3\pi \cdot 10^6}$$

$$\text{Whence we obtain } L = 212 \mu\text{H.}$$

$$C = 53 \text{ pF.}$$

The total delay is 6  $\mu$ s, whilst the delay per section is

$$\sqrt{LC} = \frac{1}{3\pi} \mu\text{s.}$$

Hence the number of sections required is

$$6 \div \frac{1}{3\pi} = 18\pi \doteq 57$$

Chap. 3, Sect. 16

Hence 57 sections are required, each with total series inductance 212  $\mu\text{H}$  and total shunt capacitance 53 pF.

- (iii) To construct a pulse-forming network of 6 sections to match to a 800 ohm load and to have a double delay time of 1.0  $\mu\text{s}$ .

$$\text{We have } \sqrt{\frac{L}{C}} = 800.$$

$$6 \sqrt{LC} = 0.5 \cdot 10^{-6}$$

$$\text{Hence } 6L = 800 \cdot 0.5 \cdot 10^{-6}$$

$$\therefore L = \frac{400}{6} \text{ microhenries}$$

$$\doteq 67 \text{ microhenries.}$$

$$\text{Similarly } 6C = \frac{0.5 \cdot 10^{-6}}{800}$$

$$\text{Hence } C = \frac{0.5 \cdot 10^{-6}}{6 \cdot 800} \text{ pF}$$

$$\doteq 104 \text{ pF.}$$

Hence each section has total series inductance 67  $\mu\text{H}$  and shunt capacitance 104 pF.

RESOLVING NETWORKS

17. General

In radar circuits it is often required to produce a voltage proportional to the sine or cosine of some variable angle. This angle may be an angle of azimuth or elevation, or it may be a phase angle corresponding to a time-delay, such as is involved in the measurement of range. In any case there are three principal types of resolver that are used in practice; these are :-

- (i) the Resistive Resolver (Sine Potentiometer),
- (ii) the Inductive Resolver (Magslip Resolver),
- (iii) The Capacitive Resolver.

Type (i) may be used with AC or DC supplies; types (ii) and (iii) can be used only with AC supplies. Type (iii) is not encountered as a resolver alone, being employed only in the capacity phase-shifting network described in Sec. 22. It will not be described separately.

18. Resistive Resolver

The basis of this device is illustrated in Fig. 89. A wire-wound resistor OP is made into a non-linear potentiometer so that for movement  $\theta$  of the slider the resistance tapped between O and Q is proportional to  $\sin \theta$ .

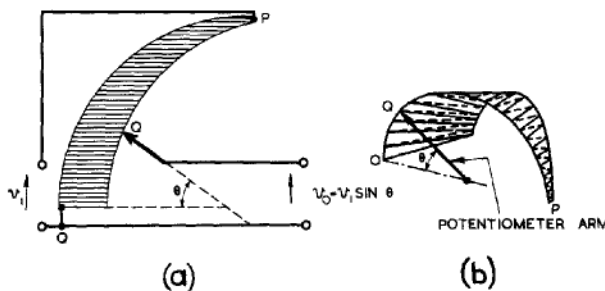

Fig.89.- Resistive resolver (sine potentiometer).

Since  $R \propto \sin \theta$

$$\delta R \propto \cos \theta \delta \theta,$$

so that if  $\delta R$  is the incremental resistance for each turn of the wire on the former, corresponding to a length  $\delta l$ , and provided the resistance per unit length of the wire is uniform,

$$\delta l \propto \cos \theta.$$

This means that the wire may be wound on a former having the shape of a cosine function as shown (Fig. 89(b)).

A group of four such cosine-law resistors may be arranged as shown in Fig. 90(a) to give continuous resolution. As the potentiometer arm turns through an angle  $\theta$  the direct voltage tapped from the resolver varies as shown at (b). If an alternating supply is used, as shown in

Fig. 91 the input voltage being  $v_i$ , the output voltage is  $v_o = v_i \sin \theta$ , as for the DC circuit.

Such a resolver, although accurate for direct or low-frequency alternating currents, is not often used for frequencies of several kilocycles or more because of the effect of stray capacitance, and because inductive resolvers are more suitable at such frequencies. Instead of the accurately wound sinusoidal potentiometers, linear resistances may be used to give a rough type of resolution as shown in Fig. 92. The eight feed points are taken to the supply voltages as shown at (a) and as  $\theta$  varies the voltage tapped from the resolver follows the graph shown at (b). Although such a device is inaccurate as a straightforward resolver, it finds a useful application in the resistive type of phase-shift network described in Sec. 23, where the inaccuracies of the method do not matter greatly because of the special requirements of the system.

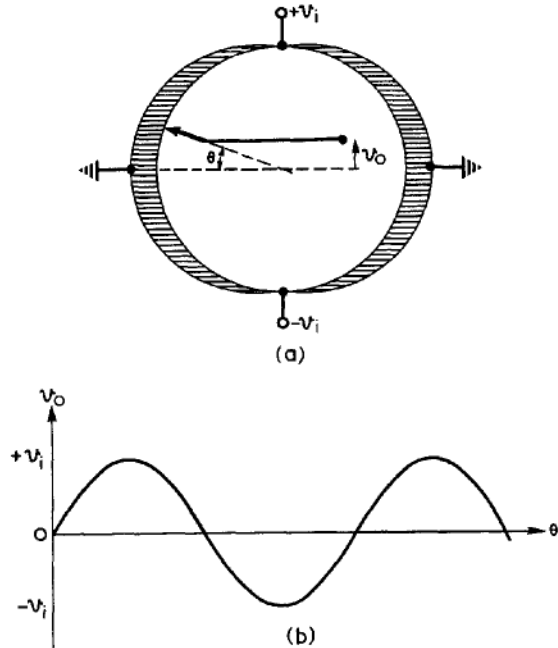

Fig. 90.- Sine potentiometer arranged to give continuous resolution.

19. Inductive Resolver (Fig. 93)

The inductive resolver consists fundamentally of two coils, a stator and a rotor, the alternating supply normally being fed to the former and the output being taken from the latter via sliprings. Alternatively the roles of the two coils may be reversed. The coils are mounted on a common diameter and wound in such a manner that the mutual inductance between them is proportional to the cosine of the angle  $\theta$  between the coil positions. Hence the voltage induced in the output coil is proportional to the product of the input voltage and  $\cos \theta$ ; Fig. 93(b).

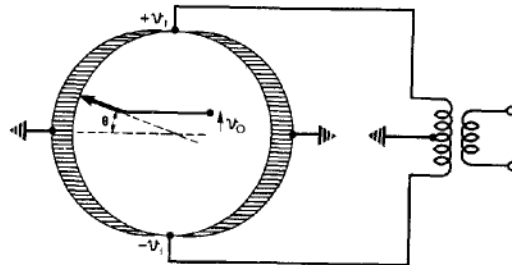
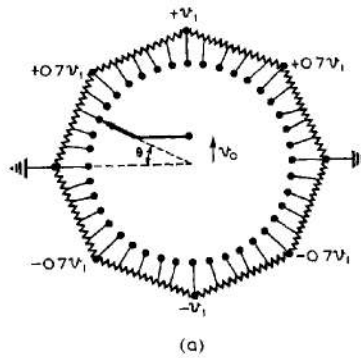
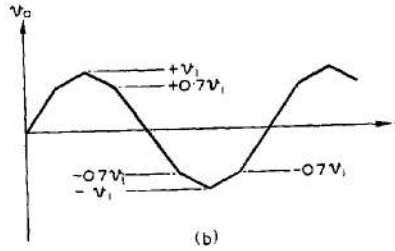

Fig. 91.- Sine potentiometers used with AC supply.

There is a large leakage inductance, so that there is very little effect of the output circuit on the input, the reflected impedance being small compared with the impedance of the primary circuit. This is important, since otherwise the variation of the reflected impedance with the position of the rotor would appreciably affect the primary current and introduce errors whose magnitude would vary with the secondary load.



If the supply is fed to the rotor, and two identical stators are used, perpendicular to each other, voltages proportional to  $\sin \theta$  and  $\cos \theta$  may be obtained simultaneously from the two stators, as indicated at (c).



Magslip transmitter elements designed to operate in this way are commonly known as Magslip resolvers (See Chap. 19, Sects. 7 and 9).

Fig. 92.- Approximate resolution using linear potentiometers.

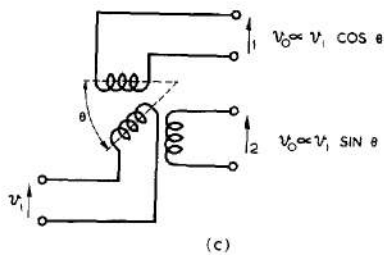
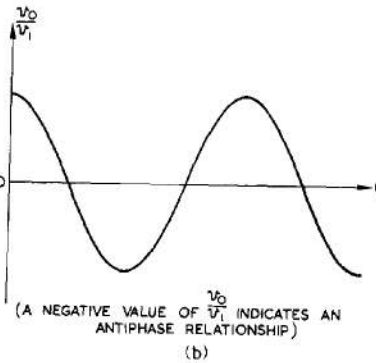
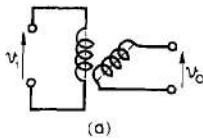

Fig. 93.- Inductive resolver.

CONTINUOUSLY VARIABLE PHASE-SHIFTINGDEVICES20. General

In sections 8 - 11 it was shown how, in an iterative filter network, there is a progressively increasing phase delay between output and input terminals as the number of sections is increased. If the number of sections is varied it is possible to choose a voltage with any desired phase relationship to the input, within the limits of the phase-step from one section to the next. In radar it is often necessary to be able to perform this process of phase variation throughout the range 0 - 360° continuously, for the purpose of obtaining a sinusoidal voltage variation in the required phase relation with a fixed-frequency input voltage. This process is not concerned with time-delays and should not be confused with the more general problem of the use of delay lines, usually employed to introduce time-delays into circuits handling signals of pulse form; although the latter method is applicable to the production of phase delays in sinusoidal oscillations, the circuits are usually more clumsy and of wider application than is necessary. For example, where this method is employed, for the sake of accuracy the phase-change per section must be kept small, so that a large number of sections must be used.

The more common method of providing 0 - 360° continuously variable phase-shift is to start with two sinusoidal voltages of the required frequency, in quadrature. If these are added or subtracted in the correct proportions an output voltage may be obtained with any desired phase relation to the input.

Thus, suppose the input voltages are given by

$$v_1 = A \sin \omega t \text{ and } v_2 = A \cos \omega t$$

respectively. If a fraction  $\sin \beta$  of the second is subtracted from a fraction  $\cos \beta$  of the first, an output voltage is provided given by

$$\begin{aligned} v_0 &= A \sin \omega t \cdot \cos \beta - A \cos \omega t \cdot \sin \beta \\ &= A \sin (\omega t - \beta) \end{aligned}$$

i.e., a signal delayed by a phase angle  $\beta$  with respect to the input voltage  $v_1$ .

A description is given below of three types of network used to provide continuously variable phase-shift by this method using inductive, capacitive and resistive resolvers respectively.

The Inductive Phase-Shifting Network Goniometer and the Capacitive Phase-Shifting Network both provide smoothly variable outputs, rely for their accuracy on manufacturing tolerances, and do not need adjustment (save, perhaps, for an overall adjustment equivalent to ensuring that the input voltages  $v_1$  and  $v_2$  are of equal amplitude and truly in quadrature). The Potentiometer Phase-Shifting Network is a step-by-step device relying for its accuracy on the tolerances of its component resistors; any of these may be changed without upsetting the mechanical construction of the device. By the use of a sufficiently large number of resistive steps the errors due to the device not being smoothly variable may be made negligible.

The potentiometer circuit is substantially independent of frequency. This is not usually true of the two other circuits.

21. The Goniometer

This device resembles the inductive resolver. The two quadrature input voltages  $v_1$  and  $v_2$  are applied to two stator coils whose magnetic axes intersect at right angles. A rotor coil is placed so that its magnetic axis may be rotated into coincidence with that of either stator. This is illustrated schematically in Fig.94. Normally the stator coils are split into pairs in order to generate a symmetrical stator flux, and opposite coils are connected in series.

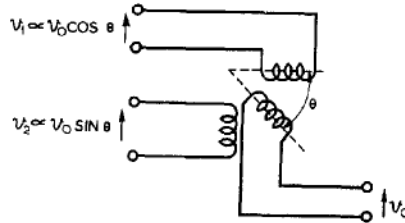
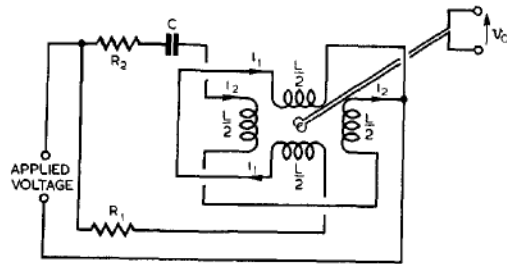

Fig.94. - Goniometer.

A method of correctly feeding such a four-stator goniometer from a single-phase supply is shown in Fig. 95. The simplified circuit is given at (b). In this circuit  $L$ , the inductance of a pair of coils in series, is the same for each stator group. If  $R_1$ ,  $R_2$  and  $C$  are correctly adjusted the currents in the stators are equal in magnitude and are in quadrature. Such an arrangement is highly sensitive to changes of frequency. For a single frequency the goniometer can be made accurate to a fraction of a degree.

22. The Capacity Phase-Shifter (Fig. 96)

This device is closely analogous to the goniometer, relying for its operation on induced electric, instead of induced magnetic fields. It takes the form of a split-stator condenser, the lower stator plate being earthed and the upper stator plate being divided into four equal sectors. Opposite pairs of plates are fed with the balanced quadrature input voltages  $v_1$  and  $v_2$ , and an unbalanced output is taken between the rotor and the earthed lower plate. If the stator and rotor plates are made to the correct shapes reasonably accurate resolution is obtained by this method, errors being normally of the order of one degree.



(a) SCHEMATIC DIAGRAM OF A GONIOMETER (4 STATORS)

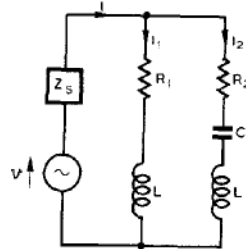

(b) SIMPLIFIED ELECTRICAL CIRCUIT OF (a)

The method of feeding the input voltages in the correct phase from a single-phase supply is the same as for the potentiometer arrangement given below.

Fig.95. - Feeding a four-stator goniometer.

23. The Potentiometer Phase-Shifting Network

This device incorporates the approximate type of resolver described in Sec. 18.

In theory, accurate resolution could be obtained using tapered resistors as described in Sec. 17, and arranged as indicated in Fig. 97. Balanced sinusoidal input voltages  $v_1$ ,  $v_2$  are applied in quadrature as shown, and the balanced output voltage is obtained from the two tapping points. In practice the necessity for accurate winding of the sinusoidal potentiometers is a drawback and linear potentiometer arrangements are used. In these a slight variation in output amplitude with phase is inevitable, but this is not usually important.

Fig. 98 gives the schematic layout of a 4-feed-point phase-shifting network, whilst the vector diagram of Fig. 99 illustrates the action. As P, Q move from A to B and from C to D respectively, the output voltage vector  $P'Q'$  changes from  $A'C'$  to  $B'D'$ , equal resistance changes corresponding to equal movements along the sides  $A'B'$ ,  $C'D'$  of the square. It follows that if the resistances between adjacent studs are all equal, equal movements of the output arm P do not correspond to equal increments of phase  $\beta$ . The graph showing errors due to using equal resistances in this four-feed-point network is shown in Fig. 100. To obtain a better approximation whilst avoiding the use of resistors of different values the eight-feed-point arrangement

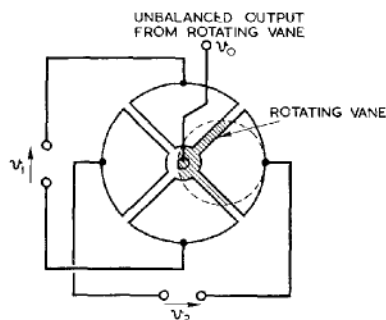

Fig. 96. - Capacitive phase-shifting network.

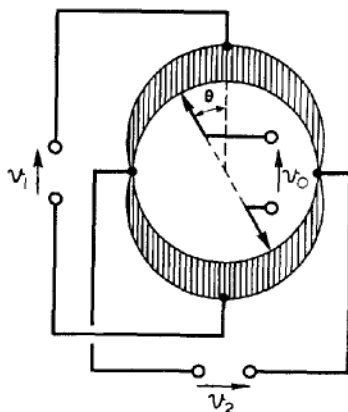

Fig. 97. - Resistive phase-shifting network, using sine-potentiometers.

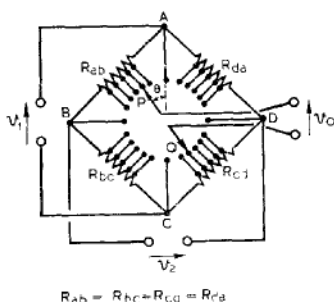

Fig. 98. - 4-feed-point potentiometer phase-shifting circuit.

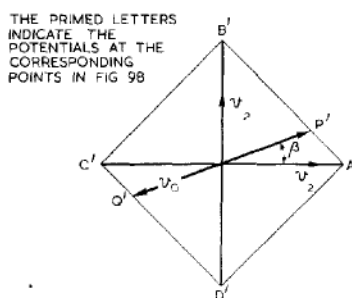

Fig. 99. - Variation of output voltage with movement of P.

shown in Fig. 101 may be employed. If the feed resistors between the input terminals and the circular resistor chain are suitably chosen the vector diagram takes the form given in Fig. 102. The output phase  $\beta$  is then the same as the angular rotation  $\theta$  at 16 points instead of 8, as in the four-feed-point arrangement, and the intermediate errors are correspondingly reduced (Fig. 103).

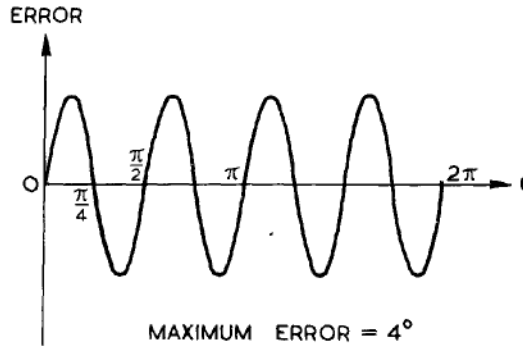

Fig. 100.- Error curve for 4-feed-point potentiometer.

One method of feeding the four points (ABCD) of Fig. 98 is shown in Fig. 104. A circuit similar to that of Fig. 104 may also be used to supply the four primary feed-points (ABCD) of Fig. 101. If the input resistance of the potentiometer between A and B or any corresponding pair

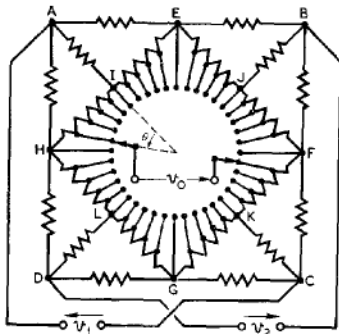
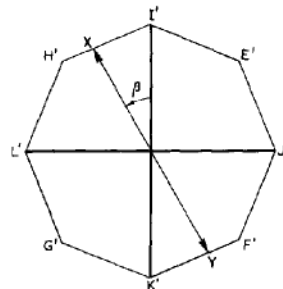

Fig. 101.- 8-feed-point potentiometer phase-shifting circuit.



THE PRIMED LETTERS INDICATE THE POTENTIALS AT THE CORRESPONDING POINTS IN FIG 101

Fig. 102.- 8-feed-point potentiometer circuit; variation of output phase and amplitude with slider movement.

of points is  $R_p$  then unless

$$R_p \gg R \dots\dots\dots (1)$$

the phase-shift circuit will be appreciably affected.

If this inequality (1) is satisfied, then the condition for voltages  $v_1$  and  $v_2$  to be in quadrature is

$$\omega CR = 1,$$

since then the voltage at B lags that at A, whilst the voltage at D leads that at A, both by  $45^\circ$ , as indicated in the vector diagram of Fig. 104(c). The voltages  $v_1$  (between A and C) and  $v_2$  (between B and D) are then equal and in quadrature.

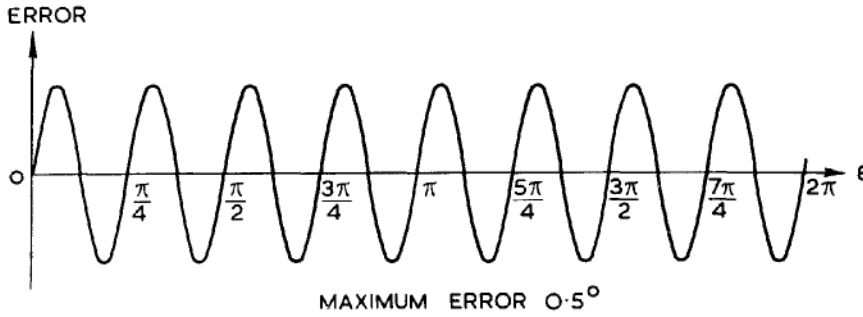

Fig. 103. - Error curve for 8-feed-point potentiometer circuit.

If the input resistance  $R_p$  between each pair of the feedpoints of the potentiometer is not negligible, the error thereby introduced can be minimised by inserting a small coil  $L$ , shown dotted in Fig. 104(a), in series with each resistor  $R$ . It can be shown from the geometry of the vector diagram (d) or by any other method of analysis that if the relations

$$L = \frac{R}{\omega^2 C (R + R_p)}$$

and

$$\frac{\omega C R R_p}{R + R_p} = 1$$

are satisfied, the figure formed by the points  $A'B'C'$  and  $D'$  of Fig. 104(d) is very nearly a perfect square, so that  $v_1$  and  $v_2$  are again equal and in quadrature.

Alternatively, the input resistance of the potentiometer circuit can be made ineffective by feeding the voltages via cathode follower circuits, which owing to their large input impedance do not appreciably load the phase-shifting C-R network.

#### 24. 0 - 180° Phase Shifting Network

The method described in Sec. 23 of feeding the four points from a single-phase supply may readily be adapted to provide variable phase-shift from 0 to nearly 180°. The circuit arrangement is indicated in Fig. 105(a), and the vector diagram (b) shows the action of the network. Provided the output impedance of the transformer is small compared with the input impedance of the network, the voltage developed between  $X$  and  $Y$  is constant, and is represented by  $X'Y'$  in (b).  $X'Z'$  and  $Y'Z'$  represent the quadrature voltages developed across  $C$  and  $R$  respectively.

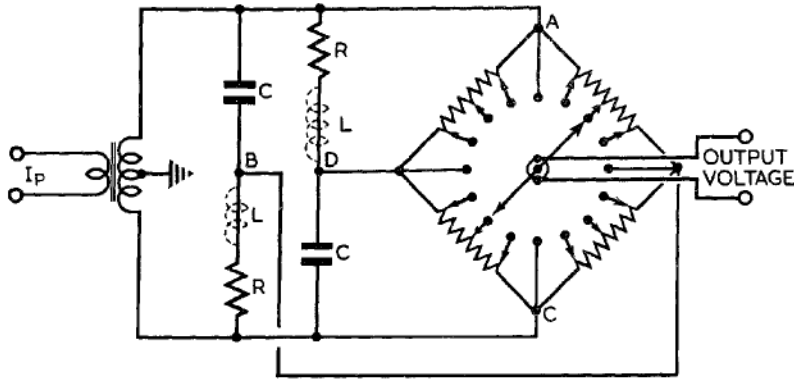

(a) SCHEMATIC DIAGRAM OF QUADRATURE FEED NETWORK FOR POTENTIOMETER PHASE SHIFTING CIRCUIT

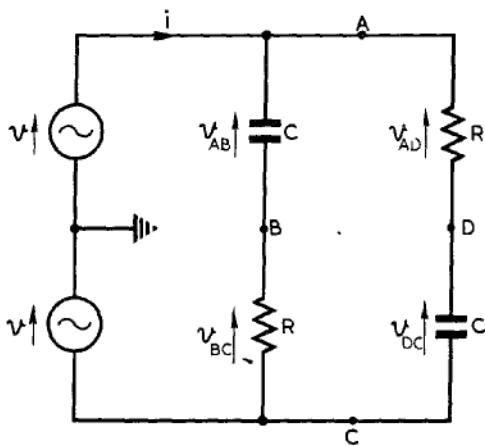

(b) SIMPLIFIED ELECTRICAL CIRCUIT OF FIG. (a)

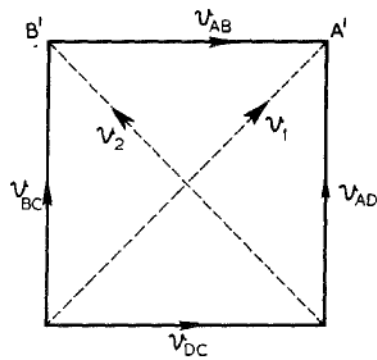

(c) VECTOR DIAGRAM

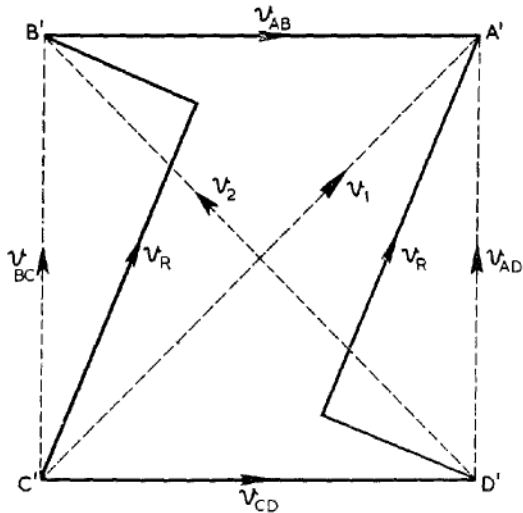

(d) EFFECT OF INTRODUCING SERIES INDUCTANCE L TO COMPENSATE FOR RESISTANCE  $R_p$  SHUNTING C

Fig. 104.- Quadrature feed network for potentiometer phase-shifting circuit.

The vector  $O'Z'$  represents the output voltage in magnitude and phase. As the value of  $R$  is varied the point  $Z'$  moves on a semi-circle on  $X'Y'$  as diameter with centre  $O'$ , since angle  $X'Z'Y'$  is always a right-angle. The output voltage, represented by  $O'Z'$ , therefore remains constant in magnitude, as the value of  $R$  (or  $C$ ) is varied, and its phase relative to that of the voltage across the transformer secondary winding can be changed through about  $140^\circ$  with practical values of  $R$  and  $C$ .

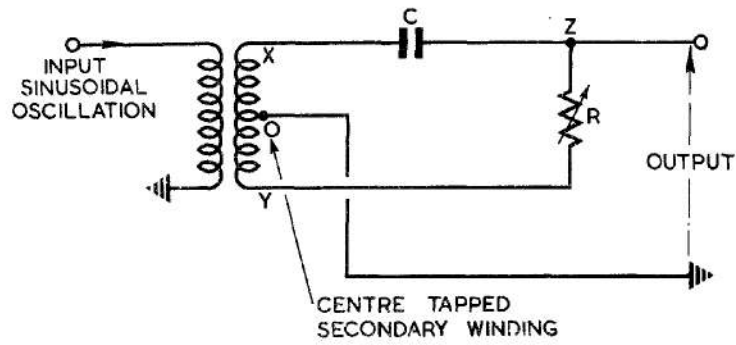

(a)

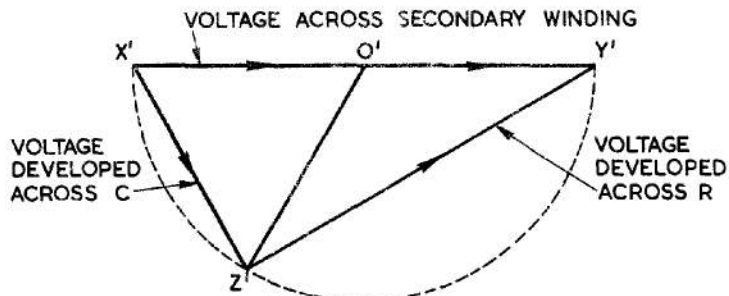

(b)

Fig. 105. -  $180^\circ$  phase-shifting network

This Page Intentionally Blank

This file was downloaded  
from the RTFM Library.

Link: [www.scottbouch.com/rtfm](http://www.scottbouch.com/rtfm)

Please see site for usage terms,  
and more aircraft documents.

