

Chapter 4
TRANSMISSION LINES

List of Contents

	Sect.
Introduction	
Circuits with distributed constants	1
Transmission lines	2
Travelling waves on uniform loss-free transmission lines	
Application of circuit laws to transmission lines	3
Interference	4
Waves of various shapes	5
Sinusoidal waves	6
Electromagnetic waves on transmission lines	7
Uniform loss-free lines : Reflection at the termination and its effects	
Reflection of a rectangular wave	8
Coefficient of reflection	9
Line fed by a DC generator	10
Deduction of line characteristics	11
Discharge of open-circuited line	12
Reflection of sine waves	13
Standing waves on a uniform open-circuited loss-free line	14
Standing waves on a uniform short-circuited loss-free line	15
Input impedance of a uniform loss-free line for any termination	16
Fundamental line characteristics	
Distributed elements for a loss-free line	17
Distributed elements for a lossy line	18
Characteristic impedance	19
Propagation constant	20
Vectorial representation	21
Lines with low losses	
Effects on line characteristics	22
Effects of slight losses on travelling waves	23
Effects of slight losses on standing waves	24
Energy losses	25
Resonant lines	
General nature of resonance in lines	26
Q-factor of a resonant length of line	27
Lecher lines	28
Metallic insulators	29
Quarter-wave sleeve rejector (rotating joint)	30
Stub reactances	31
Matching	
Reasons for matching	32
Half-wave transformer	33
Quarter-wave matching sections	34
Double quarter-wave line	35
Matching by stubs	36
Slugs	37
Balance to unbalance transformer	38
Standing wave indication	39
Common T/R circuits	40

	Sect.
Limitations of transmission lines	
Resistive and dielectric losses	41
Resistive losses	42
Dielectric losses	43
Frequency effects	44
Coaxial cables with low losses	45
Other losses in open-wire feeders	46
Circle diagrams	
Introduction	47
Normalised impedances and admittances	48
The cartesian circle diagram	49
Applications of the circle diagram	50
Numerical examples	51
Use of circle diagram to determine the magnitude of the load impedance from a knowledge of the standing wave pattern	52
Application of circle diagrams to lines with low losses	53
Application of circle diagrams to matching devices constructed from sections of uniform loss-free transmission line	54

CHAPTER 4

TRANSMISSION LINES

INTRODUCTION

1. Circuits With Distributed Constants

The theory of circuits with "lumped constants", based on the laws of Kirchhoff, Ohm and Faraday, is really the theory of idealised circuits having no "size", i.e., in which all significant dimensions are small compared with the appropriate wavelength. Although the components in the material arrangements have size and shape, with electrical and magnetic properties which involve the space around them, simple circuit theory reduces these complex properties to those of ideal resistances, inductances and capacitances, in circuits where there is no time delay between the application of an EMF at one point and the related voltage produced at another. A simple example is the tendency, in circuit theory, to consider only the components, or lumped constants, and to ignore the connections which form, in low-frequency circuits, the greater portion of the path-length of a complete network. The interactions between the currents in these connections, and the time taken for a wave to travel along them, are of major importance at high frequencies.

The theory of circuits having "distributed constants" makes an attempt to widen the scope of the method of lumped constants, with considerable success. However, particularly at very high frequencies, there are many problems to which it fails to provide a satisfactory answer, and it is often necessary to resort to the fundamental physics of electromagnetism.

In this consideration of transmission lines, the transition from the theory of lumped constants to that of distributed constants will be preceded by a discussion of electromagnetic wave propagation formulated mainly in terms of the current in, and potential differences between, the conductors which form the lines. The more fundamental considerations of the behaviour of the electric and magnetic fields associated with such currents and voltages will be dealt with in Chap. 5.

2. Transmission Lines

In general terms, a Transmission Line is a device for guiding the flow of electromagnetic energy from one place, where it is available, to another, where it is to be utilised. The word Waveguide has precisely the same significance, though it is usual to restrict the application of this term to systems embodying a single tubular conductor (or dielectric rod, in some cases) and to use the term Transmission Line for systems using two conductors (or more).

A uniform transmission line is one in which the electrical properties of the line (per unit length) do not vary throughout its length; i.e. it usually has a constant cross-section. Non-uniform, or tapered, transmission lines are occasionally used, but their properties are not covered by this chapter, which is concerned solely with the behaviour of the uniform transmission line with two conductors. These conductors may be separate (parallel or twisted pair) or coaxial (concentric line). The separation between the conductors must be small compared with the wavelength. (see Secs. 7 and 46 and Chap. 5, Sec. 12)

Chap. 4, Sect. 2

Typical transmission lines used in radar are shown in Fig. 106. The electrical properties of the lines depend not only upon the size, shape and disposition of the conductors, but also upon the dielectric which maintains that disposition, and the extent to which the arrangement is constant, or varies with movement or change in atmospheric conditions. Where a uniform solid dielectric is used, with the wires embedded, as shown in Fig. 106(a), it is possible to maintain reasonably constant electrical properties by the exclusion of atmospheric variations and by the constant spacing which can thus be maintained between the conductors. The disadvantage of this type of cable is loss of energy in the imperfect dielectric. The other extreme is the open-wire feeder construction of Fig. 106(b). Here dielectric losses are low except at the spacers, which are apt to cause serious trouble if they get very wet.

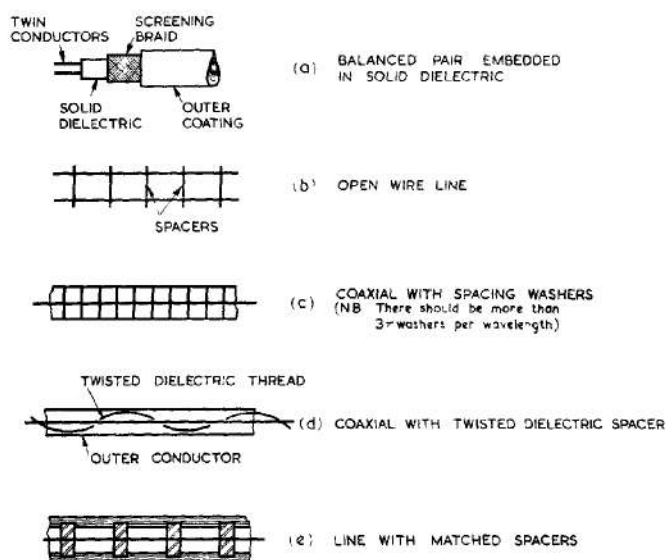

Fig. 106 - Typical transmission lines used in radar.

Their presence inevitably introduces non-uniformity, which makes the behaviour of the line more difficult to predict and thus less easy to control. This problem of suspension also applies to coaxial cables with mainly air dielectric where the inner must be maintained in a position fixed relative to the outer. Various arrangements are illustrated in Figs. 106(c), (d), (e), showing how attempts are made to satisfy both requirements, uniformity and low losses. Particular arrangements which avoid the use of dielectric supports are described in Sec. 29. Losses due to induction and radiation, which may make open-wire lines unuseable as transmission systems at VHF, is dealt with in Sec. 46.

Under certain circumstances, waveguides are to be preferred to twin-conductor systems, as discussed in Chap. 5, Sec. 5.

Although the primary function of a transmission line is to transmit energy, other applications arise, particularly with short lengths of line; e.g., reactive circuit elements, resonant circuits, and impedance-transforming devices. In these special applications, as with all reactors, it is the storage, rather than the transmission

of energy, which is more important.

TRAVELLING WAVES ON UNIFORM LOSS-FREE TRANSMISSION LINES

3. Application of Circuit Laws to Transmission Lines

For simplicity it will be assumed that in the ideal transmission lines about to be discussed there are no energy losses. Such conditions approximate to those encountered in the practical cables shown in Fig. 106, or in parallel lines in the form of broad metal ribbons, pictured in Fig. 107. Since the distributions of charge and electric and magnetic fields in the latter case are more simply represented, the diagrams which follow will apply to this arrangement.

The evolution of a coaxial line from the ribbons is suggested in Fig. 108, the ribbons being bent to form the inner and outer of a coaxial pair; the electric and magnetic fields associated with the current in the conductors are then confined to the space between them, as they would be, substantially, between the parallel plates in the original arrangement.

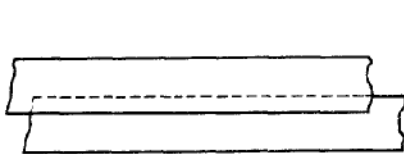

Fig. 107 - Parallel lines in form of broad metal ribbons.

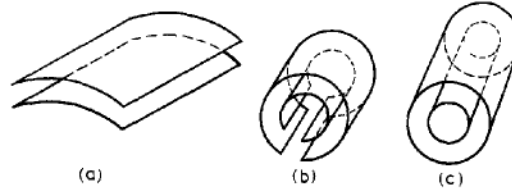

Fig. 108 - Bending parallel plate lines to form coaxial pair.

It can be shown that electromagnetic waves may be propagated without distortion along such a transmission line with a velocity u where

$$u = \frac{1}{\sqrt{L_l C_l}}, \quad L_l \text{ and } C_l \text{ being the}$$

inductance and capacitance per unit length of the line.

Moreover, at any portion of the wave, a change in potential difference between the conductors is always related to a change in the wave current flowing in the conductors by the relation

$$\frac{dv}{di} = \sqrt{\frac{L_l}{C_l}}$$

A method of deriving these fundamental results is given below. A simpler approach is given in Section 11.

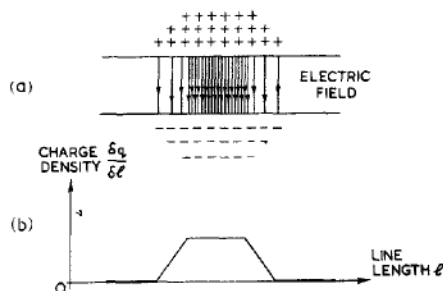

Fig. 109 - Instantaneous charge distribution on a section of the line of fig. 107.

Derivation of Formulae

Suppose there is at any instant a charge distribution on the line as illustrated in Fig. 109. This corresponds to the potential difference between the conductors shown in Fig. 110 and enlarged in Fig. 111, since $V \propto Q$. Considering the small section of the line of width δl in Fig. 112(a), it is seen that there is a resultant potential difference in the circuit equal to δv (see Fig. 112(b)). Since there are no other sources of EMF present, this must be due to the EMF induced by the changing current according to Faraday's law,

* $\delta v = -\delta L \frac{\partial i}{\partial t}$, where δL is the inductance of the small circuit.

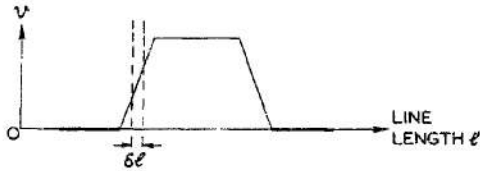

Fig. 110 - Instantaneous potential distribution corresponding to fig. 109.

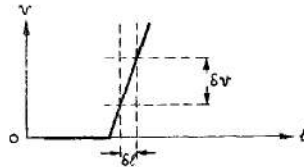

Fig. 111 - Enlarged diagram showing potential distribution of section δl .

If L_l is the inductance per unit length of the transmission line,

$$\delta L = L_l \delta l$$

so that $\delta v = -L_l \frac{\partial i}{\partial t} \delta l$

i.e. * $\frac{\partial v}{\partial l} = -L_l \frac{\partial i}{\partial t}$ (1).

There is thus present at the sloping portion of the 'pulse' a current changing with time, so that the pulse cannot be stationary. If δi is the difference in current between the two ends of the section, (see Fig. 112(c)),

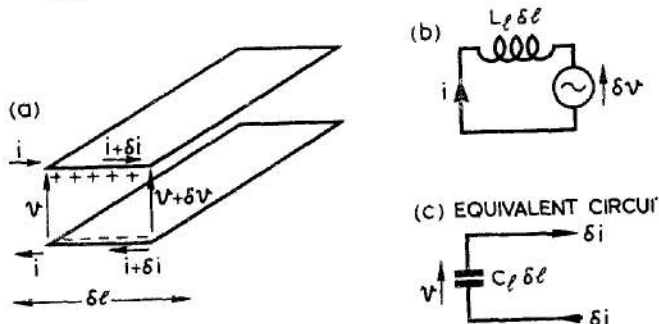

Fig. 112 - Enlarged diagram of section of line of length δl , with currents and voltages.

* $\frac{\partial}{\partial l}$ indicates a change with length l for t constant.

$\frac{\partial}{\partial t}$ indicates a change with time t for l constant.

$$\begin{aligned} \delta i &= -\frac{\partial}{\partial t} (\delta q) \\ &= -\frac{\partial}{\partial t} (C_l \delta v) \\ &= -C_l \frac{\partial v}{\partial t} \delta l. \end{aligned} \quad \begin{array}{l} \text{(If the current increases} \\ \text{the charge left on the} \\ \text{line decreases; hence} \\ \text{the - sign)} \end{array}$$

Hence $\frac{\partial i}{\partial l} = -C_l \frac{\partial v}{\partial t} \dots\dots\dots(2).$

We shall now show that relations (1) and (2) are consistent with the pulse travelling without changing its shape, either to the right or to the left, with velocity $\frac{dl}{dt} = u = \frac{1}{\sqrt{L_l C_l}}$, and such

that $\frac{dv}{di} = \sqrt{\frac{L_l}{C_l}}$

From (1) we have:- $\frac{\partial v}{\partial l} = -L_l \frac{\partial i}{\partial t}$
 $= -L_l \left[-\frac{\partial i}{\partial l} \cdot \frac{dl}{dt} \right]$
 $= u L_l \frac{\partial i}{\partial l}.$

Similarly, from (2) we have:- $\frac{\partial i}{\partial l} = -C_l \left[-\frac{\partial v}{\partial l} \cdot \frac{dl}{dt} \right]$
 $= u C_l \frac{\partial v}{\partial l}.$

Combining these results, we obtain:-

$$\frac{dv}{di} = \pm \sqrt{\frac{L_l}{C_l}} \quad \text{and} \quad u = \pm \frac{1}{\sqrt{L_l C_l}}.$$

The relative dispositions of voltages, currents, electric and magnetic fields and direction of propagation are illustrated in Fig. 113. The potential difference \vec{v} is in opposition to the electric field \vec{E} , while the current \vec{i} is related to \vec{H} by Ampère's rule. \vec{E} , \vec{H} and \vec{u} form a Right-Handed Set of orthogonal vectors; i.e.,

\vec{E} , \vec{H} and \vec{u} are always arranged at right angles to one another so that a positive (clockwise) rotation through a right angle about \vec{u} will move \vec{E} into the position of \vec{H} . It follows that for two waves travelling in the same direction with \vec{E} vectors alike, the \vec{H} vectors must also be alike, whilst if the \vec{E} vectors are in opposition so are the \vec{H} vectors. A reversal in one but not the other is possible only for a wave travelling in the opposite direction. Of two pulses, travelling in opposite directions along the same transmission line, either the electric or the magnetic fields must be in the same direction, but both cannot be.

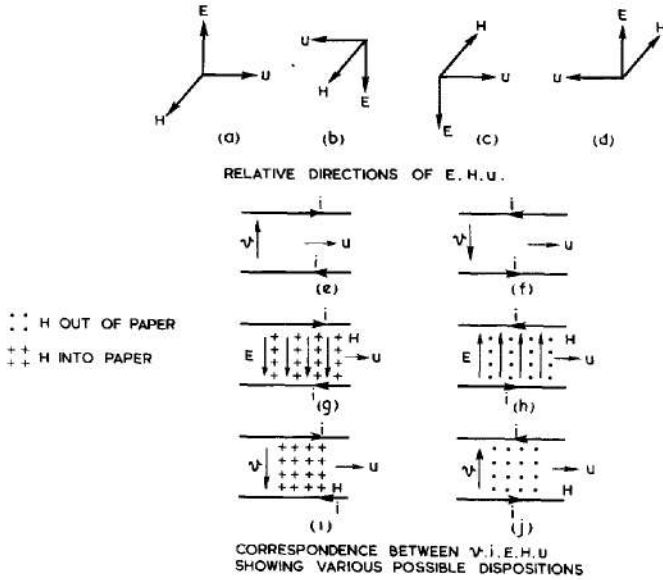

Fig. 113 - Spatial relations between v , i , E , H , and u for a travelling wave.

4. Interference

When two pulses travelling in opposite directions on a line encounter each other, the resultant distribution can be found by adding the voltages and currents of the component waves. It follows from the previous paragraph that wherever such pulses meet there will be a partial cancellation of the magnetic field and an enhancement of the electric, or vice versa. This is illustrated in Fig. 114. Although the resultant wave-pattern is said to be due to the Interference between the two waves, neither affects the other; so called interference is merely a special case of Superposition (see Chap. 1, Sec. 6). This implies that each wave may be considered separate from the other, and the resultant effect obtained by direct addition of currents, fields and voltages.

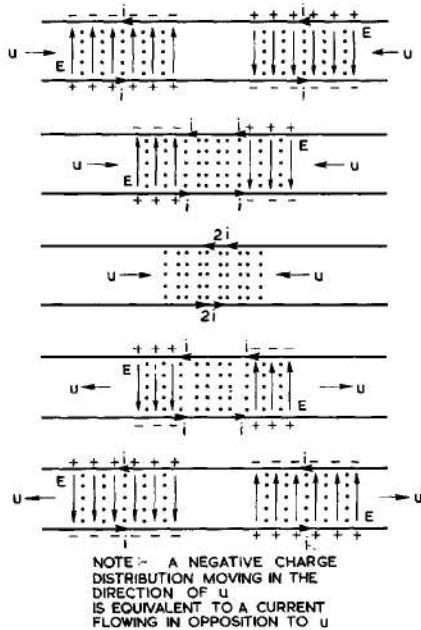

Fig. 114 - Interference between two pulses of equal magnitude.

5. Waves of Various Shapes

A travelling wave on a transmission line may be of any shape, and, if the line is uniform and lossless, it will travel along the line without change of shape, at a uniform velocity independent of the shape of the wave. This follows from the results of Sec. 3 which are independent of the shape of the charge distribution (shown in Fig. 4) and hence the shape of the wave. Figs. 115, 116, and 117 show the line and time-distribution of voltage or current for exponential, rectangular and sinusoidal waves. In each case (a) shows the variation with time of the voltage v_s (or current, since the two are proportional) at the generator or sending end, whilst (b) shows the corresponding instantaneous distribution on the line at the instant $t = t_2$. A construction line shows how one diagram may be obtained from the other; l_1 is the distance travelled in time $(t_2 - t_1)$ by the wave emitted from the generator at any instant t_1 , so that

$$l_1 = u(t_2 - t_1).$$

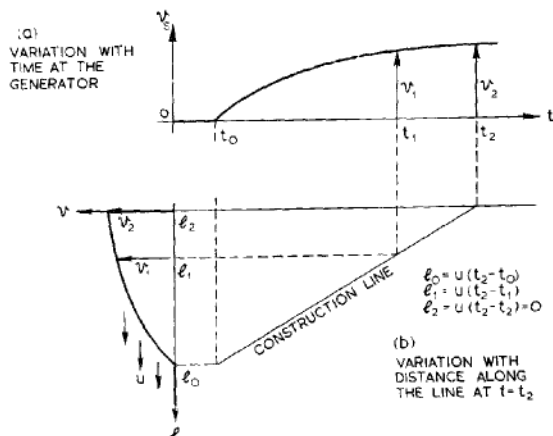

Fig. 115 - Variation of line voltage or current for an exponential wave.

Similar equations hold for the particular cases $l_1 = l_0$ and $l_1 = l_2$, corresponding to t_0 and t_2 respectively.

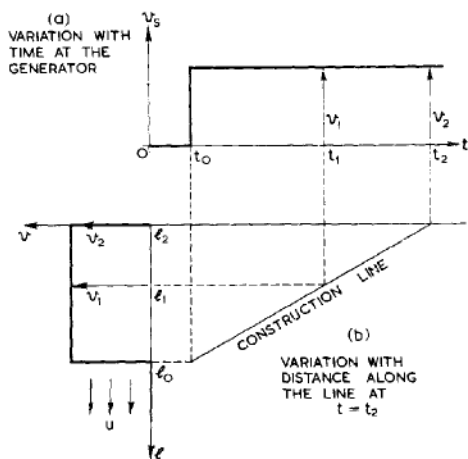

Fig. 116 - Variation of line voltage or current for a rectangular wave.

If the line is an infinite one the impedance which it presents to the generator (Input impedance, Chap. 3) is constant and independent of the type of wave. If finite, but properly terminated, the line appears to the generator to be an infinite line, and behaves as such. If the line is improperly terminated, reflections occur from the end, and interferences between the direct wave and reflected wave causes a change in the input conditions. The nature and extent of these changes will be considered in Secs 8 - 16.

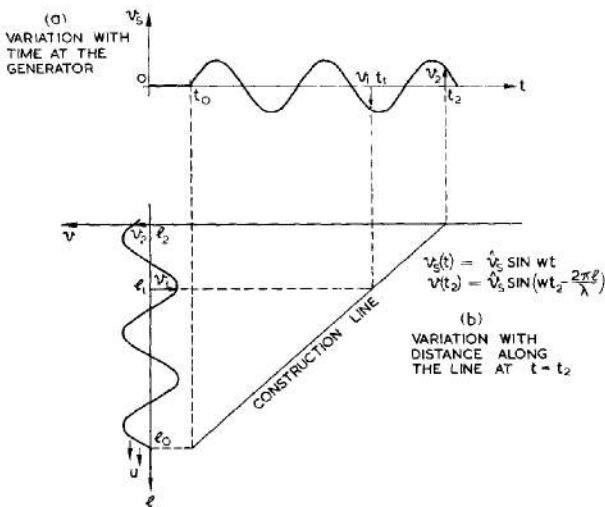

Fig. 117 - Variation of line voltage or current for a sinusoidal wave.

6. Sinusoidal Waves

In the particular case of the sinusoidal wave of Fig. 117, three conditions characteristic of travelling waves are particularly noteworthy:-

(i) The amplitude of the voltage variations is the same for all points of the line, and similarly for the current variations.

This is obvious from preceding paragraphs.

(ii) The variation of phase with distance is given by the relation:-

$$\phi = \phi_s - \frac{2\pi l}{\lambda}, \quad \text{for both voltage and current.}$$

ϕ_s is the phase at the sending end.

This follows if we define the wavelength, λ , as the length of the line over which the phase variation at any instant is 2π . Since the phase at the generator varies uniformly with time, and the distance travelled is proportional to time, the phase varies uniformly with the distance along the line.

(iii) The input impedance of the line to an applied sinusoidal EMF is the characteristic impedance $\sqrt{\frac{L_f}{C_f}}$.

We have shown that, for a wave travelling along a uniform loss-free line, at any point the ratio of change in voltage to change in current is constant and equal to $\sqrt{\frac{L_f}{C_f}}$; this implies that the voltage and current are in phase, i.e. that the impedance is a pure resistance

of value $\sqrt{\frac{L_f}{C_f}}$. This impedance is called the Characteristic (or Surge) Impedance of the line, and is denoted by R_0 . (The reciprocal of R_0 , G_0 , is the characteristic admittance. The characteristic impedance is purely resistive only for the case of a distortionless line (see Sec. 19). In the general case of a line which is not loss-free the characteristic impedance and admittance are complex, and are denoted by z_0 and y_0 respectively.)

7. Electromagnetic Waves on Transmission Lines

The types of waves which have so far been considered do not cover all the modes in which electromagnetic energy may be propagated along transmission lines. Such modes may be grouped into two main classes:-

- Principal Modes,
- Supplementary Modes.

Principal Modes

These are the progressive waves normally used in transmission lines, and those which have been described in Secs. 3 - 6 belong to this category. The notable features of these waves, when the transmission lines are perfectly conducting, are the following:-

- (i) They are propagated at the speed of electromagnetic plane waves in an unbounded medium. This speed u is given by:-

$$u = \frac{c}{\sqrt{K\mu}},$$

where $c = 3 \times 10^8$ m. per second, and K and μ are respectively the dielectric constant and magnetic permeability of the dielectric that fills the space between the conductors. It is independent of frequency.

- (ii) They are transverse electromagnetic waves: that is, the vibrations of E and H take place everywhere in planes (the wave fronts) at right angles to the direction of propagation (along the axes of the lines); also E and H vibrate in phase.
- (iii) The electric field E and magnetic field H are everywhere at right angles in the field pattern.
- (iv) The ratio of the field strengths E and H is the same at all points. Thus in the MKS system of units.

$$\frac{E}{H} = 120 \pi \sqrt{\mu/K} \text{ ohms} \quad \left(\begin{array}{l} E \text{ in volts per metre} \\ H \text{ in ampères per metre} \end{array} \right)$$

- (v) At a cross-section where the potential difference between the conductors is v a skin current i flows (at high frequencies) in the surface of one conductor and an equal and opposite current in the surface of the other. When a single sinusoidal wave train passes any cross-section the potential v and the current i oscillate in phase and their ratio v/i remains constant and the same at all times for all cross-sections. This ratio which is fixed by the geometry of the system and the dielectric constant of the separating medium is an important property

of the particular transmission line system. It is called the Characteristic Impedance of the system and is usually denoted by the symbol z_0 .

Thus, if v and i are complex numbers representing the voltage and current at any section of the line, then

$$v = z_0 i.$$

Supplementary Modes

Other modes of propagation, each with its own field pattern, can be propagated along a transmission line, in addition to the usual principal mode. In these supplementary modes the electromagnetic field, as in wave guides, possesses either a component of E (E-modes) or of H (H-modes) parallel to the direction of propagation. These modes, like the waves in waveguides, exhibit the phenomenon of cut-off. For each there is a cut-off frequency which is determined by the geometry of the transmission line system. In normal practice the spacing of the transmission lines is small in comparison with the wavelength and the supplementary modes can appear only as Evanescent disturbances, as described in Chap. 5, Sec. 12.

At a geometrical discontinuity in the transmission line system such as a sharp bend or a shunting load, the electromagnetic field assumes a complicated form and in general possesses longitudinal as well as transverse components. It cannot therefore be represented by principal waves alone. Thus, supplementary modes also are excited at the discontinuity. In practice all supplementary modes will be evanescent and at a sufficient distance from the discontinuity their field amplitudes become negligible compared with those of the principal waves.

Evanescent modes carry no power along the transmission lines and their E and H fields are storage fields similar to those of a condenser or an inductance. The storage field excited by a discontinuity does in fact contribute an effective shunting reactance to the transmission line at the discontinuity. A consequence of this reactive behaviour of evanescent modes is that the effective value of the impedance z_l of a circuit component, such as a resistor, when added in shunt across the line may be quite different from its nominal value z_n that would be anticipated from its electrical behaviour at low frequencies.

The presence of evanescent modes begins to be important at wavelengths of $\frac{1}{2}$ metres and is very important at wavelengths of 10 centimetres and less. At wavelengths greater than a few metres the effect of the storage fields of the evanescent modes excited at discontinuities may be neglected.

The usual theory of transmission lines is the theory of the principal wave and ignores the behaviour of supplementary modes. From what has preceded it is apparent why the standard treatment is adequate when the wavelength exceeds a few metres but gives an incomplete description of transmission line phenomena at wavelengths less than $\frac{1}{2}$ metres.

UNIFORM LOSS-FREE LINES: REFLECTION AT THE TERMINATION, AND ITS EFFECTS

8. Reflection of a Rectangular Wave

We shall assume that the line has a characteristic impedance which is purely resistive and of value R_0 , independent of frequency, and that the electromagnetic disturbances considered are propagated without distortion along the line with uniform velocity u .

A DC generator whose output resistance is R_0 , is connected to a section of uniform line of length l , terminated in R_r which is not necessarily equal to R_0 . The circuit is shown in Fig. 118(a). Initially the line is uncharged, and the current everywhere is zero. As the switch S is closed, a wave begins to travel from the sending to the receiving end of the line. Current flows in both conductors as illustrated in Fig. 118(b) and the line becomes progressively charged.

If the open-circuit EMF of the generator is V_0 volts, the voltage V_+ which is impressed on the line is $\frac{V_0}{2}$, and the current I_+ which flows in the travelling wave is

$$\frac{V_+}{R_0} = \frac{V_0}{2R_0}.$$

[The suffixes + and - refer to the waves travelling away from and towards the generator respectively. The suffixes r and s refer to the receiving and sending end respectively.]

When the wave front reaches the receiving end current begins to flow through the load, and a potential difference is set up across the load resistance R_r . If $R_r = R_0$, the energy of the wave is completely absorbed in the termination, and the same conditions obtain on the line as if it were part of an infinite line. The energy absorbed by the load must be supplied by a load voltage V_l and current I_l satisfying the relation

$$\frac{V_l}{I_l} = R_r,$$

and if $\frac{V_+}{I_+}$, which equals R_0 , is not equal to R_r , such conditions cannot be maintained without some energy from the direct wave being "rejected" by the load. A wave is then reflected back towards the sending end as if the termination behaved partly as an absorber of energy and partly as a new generator. If $R_r > R_0$, the voltage developed across the load is greater than V_+ , whilst if $R_r < R_0$, the current through the load is greater than I_+ . In both cases the resultant load voltage and current must arrange themselves in the ratio

$$\frac{V_l}{I_l} = R_r.$$

It is convenient to represent the line as consisting of an upper and a lower conductor having a sending end on the left and a receiving end on the right, and to adopt the following sign conventions:-

- (i) for a wave travelling away from the sending end (direct wave)
voltage is measured positively from the lower to the

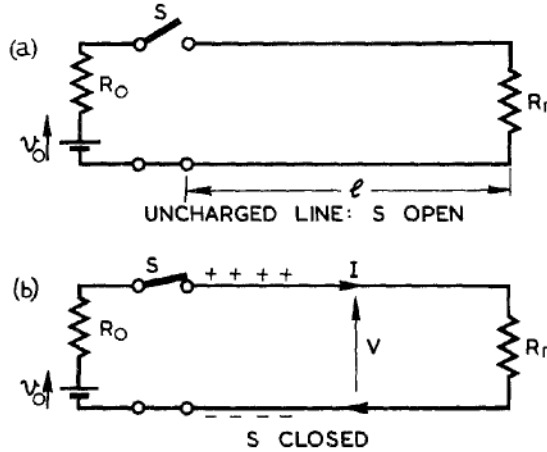

Fig. 118 - Application of a rectangular wave to a transmission line,

upper conductor; conventional current is measured positively to the right in the upper conductor, and to the left in the lower conductor.

(ii) for a wave travelling towards the sending end (reflected wave)

voltage is measured as before, positively from the lower to the upper conductor; conventional current is measured positively to the left in the upper and to the right in the lower conductor.

9. Coefficient of Reflection

Suppose a fraction ρ of the sending wave of Sec. 8 is reflected, so that the resultant load voltage is $V_+ + \rho V_+$ (the charge density of the reflected wave being ρ times that of the direct wave). Since the ratio of voltage to current in any wave transmitted by the line is R_0 , the magnitude of the current in the reflected wave is $\rho \frac{V_+}{R_0} = \rho I_+$.

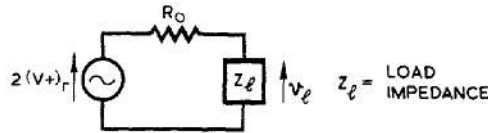

Fig. 119 - Equivalent circuit.

Thus $V_l = V_+ + \rho V_+$ and $I_l = I_+ - \rho I_+$, the current of the reflected wave being in opposition to that of the direct wave.

$$\text{Hence } \frac{V_l}{I_l} = \frac{V_+ (1 + \rho)}{I_+ (1 - \rho)}$$

$$\text{i.e. } R_r = R_0 \frac{(1 + \rho)}{(1 - \rho)}$$

$$\text{i.e. } \rho = \frac{R_r - R_0}{R_r + R_0}$$

ρ is called the Coefficient of Reflection. Its magnitude varies between +1 (for $R_r = \infty$) and -1 (for $R_r = 0$); and it is zero when $R_r = R_0$. (The case where ρ is complex is dealt with briefly in Sec. 13).

It is sometimes convenient to use the equivalent circuit shown in Fig. 119 for deriving the voltage and current produced at the load by a wave which travels to, and is partly reflected from, the termination. The equivalent generator voltage $2(v_+)_r$ is twice the instantaneous value of the voltage of the direct wave measured at the receiving end. This circuit is valid for any type of wave and is particularly useful in transient problems where the nature of the direct wave is known, since it gives the load voltage and current directly without the resultant line voltage having to be determined first.

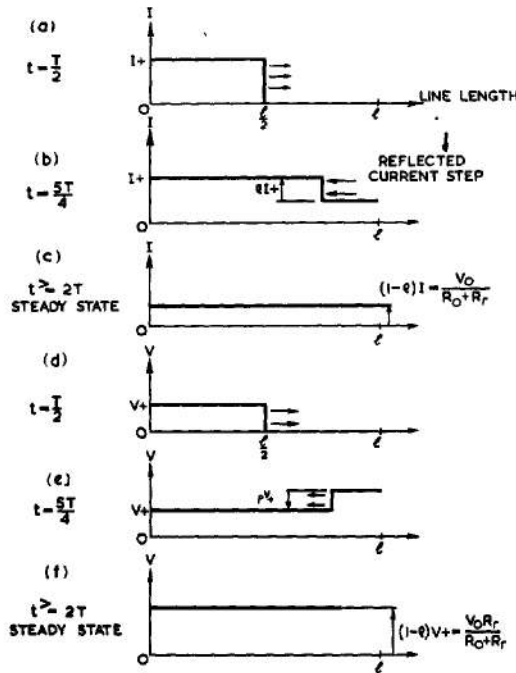

Fig. 120 - Current and voltage distribution on the line of fig. 118 at various intervals after closure of switch S (Drawn for $R_r > R_o$).

10. Line Fed by a DC Generator

The voltage and current distribution on the line of Fig. 118 at various intervals after the closure of the switch S are shown in Fig. 120. The conditions at the input terminals are shown plotted against time in Figs. 121 and 122. It should be noted that since the generator output impedance is R_o , the conditions at the load after time T , and at the generator after time $2T$ are the same as if the line were a "short-circuit", in series with R_r . If the generator output impedance were other than R_o , further diminishing reflections would occur alternately at both ends and would persist until the steady condition were reached corresponding, as before, to the solution which would be obtained by simple direct-current theory.

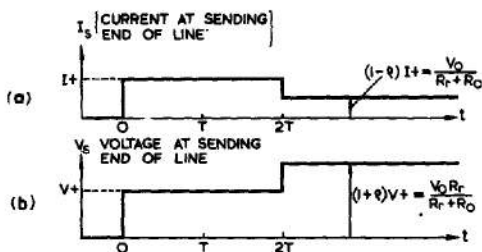

Fig. 121 - Conditions at input terminals of line shown in fig. 118, drawn for $R_r > R_o$ (ρ is positive).

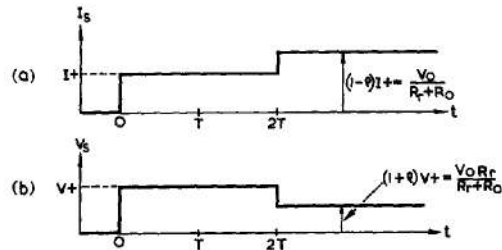

Fig. 122 - Conditions at input terminals of line shown in fig. 118, drawn for $R_r < R_o$ (ρ is negative).

For practical purposes, except in cases of severe mismatching, the steady state is reached to a sufficient degree of approximation after a few transits of the line.

11. Deduction of Line Characteristics

The fundamental characteristic properties of a uniform lossless transmission line have been deduced in Sec. 3. An alternative derivation, based on energy considerations, is given below. We assume certain properties, already demonstrated, namely, that the line is distortionless and has a characteristic impedance which is a pure resistance; also that the wave of Figs. 118 - 122 takes a finite time to travel along the line, so that the conditions at the sending end remain constant from the closure of the switch until at least $t = 2T$, when the front of the reflected wave, if any, returns. Thus, whether the line is short-circuited or open-circuited, or has any other termination, cannot be known at the generator until $t = 2T$.

If the total line capacitance is C , and the total inductance L , the following relationships obtain for a generator of internal resistance R_0 .

At the end of time $t = 2T$ the conditions are:-

Short-circuited line

$I_s = 2I_+$, $V_s = 0$, so that there is no energy stored in the electric field. The energy stored in the magnetic field is

$$\begin{aligned} & \frac{1}{2}L(2I_+)^2 \\ &= 2LI_+^2 \end{aligned}$$

Open-circuited line

$V_s = 2V_+$, $I_s = 0$, so that there is no energy stored in the magnetic field. The energy stored in the electric field is

$$\begin{aligned} & \frac{1}{2}C(2V_+)^2 \\ &= 2CV_+^2 \end{aligned}$$

In both cases the energy supplied by the generator is $V_+ I_+ \cdot 2T$.

Hence $2V_+ I_+ T = 2LI_+^2 = 2CV_+^2$

i.e. $\frac{V_+}{I_+} = \frac{L}{T} = \frac{T}{C}$.

Therefore $T^2 = LC$ so that $T = \sqrt{LC}$;

and $R_0 = \frac{V_+}{I_+} = \sqrt{\frac{L}{C}}$.

If the length of the line is l metres:-

$\frac{L}{l} = L_l$ is the inductance per unit length;

$\frac{C}{l} = C_l$ is the capacitance per unit length.

$$\begin{aligned} \text{Then } T &= \sqrt{LC} = \sqrt{L L_f / C_f} \\ &= \ell \sqrt{L_f C_f} \end{aligned}$$

Therefore the velocity of propagation is $u = \frac{\ell}{T}$

$$= \frac{1}{\sqrt{L_f C_f}}$$

Also $R_0 = \sqrt{\frac{L}{C}} = \sqrt{\frac{L_f \ell}{C_f \ell}} = \sqrt{\frac{L_f}{C_f}}$

12. Discharge of Open-circuited Line

In the arrangement shown in Fig. 123 a section of uniform loss-free cable has been charged, so that there is a potential difference of V_0 volts between the conductors, which are not connected at either end. The switch S is closed at $t = 0$, and the line begins to discharge through the load resistance R_f .

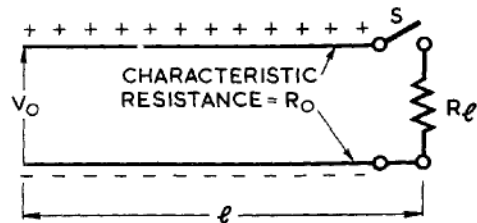

Fig. 123 - Discharge of open-circuited line.

The drop of voltage ($V_0 - V_1$) at the end which is suddenly terminated in R_f may be regarded as a rectangular voltage wave travelling away from R_f , as shown in Fig. 124 (a) and (b).

When this wave reaches the open circuit after time T , the entire line has been discharged to a new level V_1 . At this instant total reflection occurs and a second voltage wave, also of magnitude ($V_0 - V_1$), begins to travel from the open circuit towards R_f (Fig. 124(b) and (c)). This wave will reach R_f in time T after its inception, i.e. in time $2T$ from the closure of the switch. Prior to this time the load R_f must remain insensitive to any reflection effects.

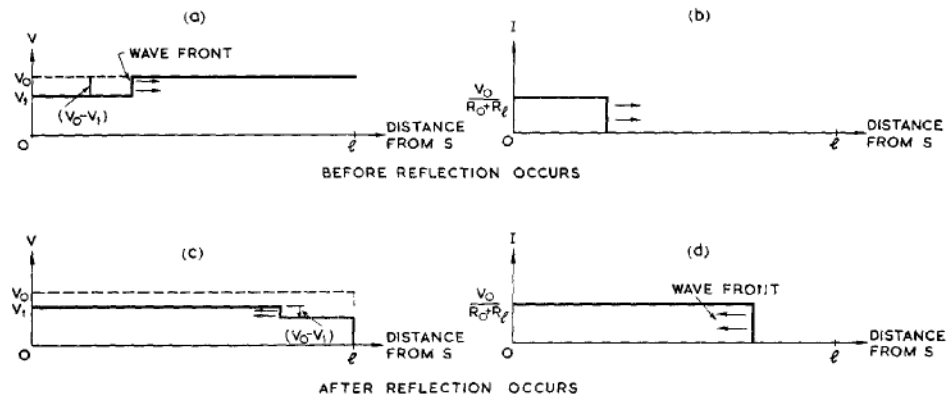

Fig. 124 - Line distribution of voltage and current before and after reflection occurs.

Chap. 4, Sect. 12

The voltage developed across the load is initially V_1 ; it remains at this level for an interval $2T$, and then changes to V_2 . We shall consider the relative magnitudes of V_0, V_1, V_2 etc., in relation to R_0 and R_l .

Initially, the line acts a generator of EMF V_0 and output resistance R_0 ; thus the voltage developed across the load is given by:-

$$V_1 = V_0 \frac{R_l}{R_0 + R_l} .$$

A negative voltage wave of magnitude $V_0 \frac{R_0}{R_0 + R_l}$ travels along the line towards the open circuit. This is reflected from the open circuit, leaving the line voltage

$$V_0 - \frac{2 V_0 R_0}{R_0 + R_l} = V_0 \frac{(R_l - R_0)}{R_l + R_0}$$

$= \rho V_0$, where ρ is the reflection coefficient for the load R_l . The line current is then zero. Immediately after the first period $2T$ the conditions are the same as at the closure of the switch, except that the line is charged to a voltage ρV_0 instead of V_0 . The whole process is repeated, with $V_2 = \rho V_1$, and after time $4T$ the line voltage is reduced everywhere to $\rho^2 V_0$ and a third voltage step $\rho^2 V_1$ begins to appear across the load.

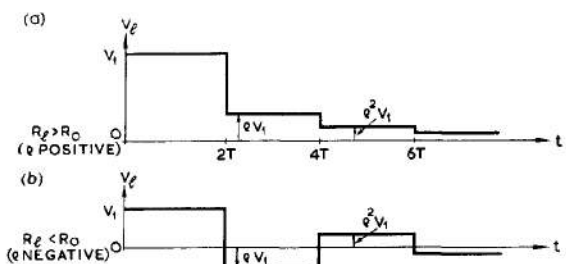
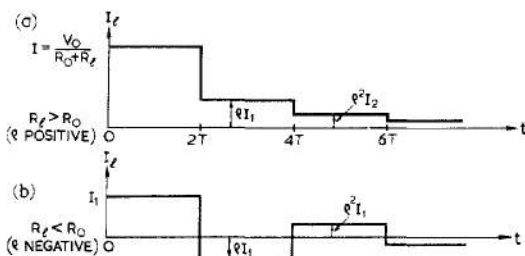

Fig. 125 - Voltage V_l developed across load with (a) ρ positive (b) ρ negative.

Fig. 126 - Current I through load with (a) ρ positive and (b) ρ negative.



The sequence is pictured in Figs. 125 and 126. In each figure (a) refers to the case where $R_l > R_0$ and (b) refers to the case where $R_l < R_0$. The decay in the energy stored in the line (Fig. 127) is quasi-exponential, similar to the decay of energy in a discharging condenser, except that the process is stepped in the former case and smooth in the latter. If $\rho = 0$ i.e. if $R_l = R_0$, the line is completely discharged after $2T$ secs.

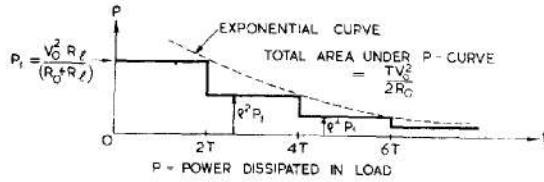

Fig. 127 - Power dissipated in load.

13. Reflection of Sine Waves

The instantaneous conditions of reflection at the receiving end of the line are exactly the same for a sinusoidal as for a constant voltage wave, but the pattern of the interference between the direct and reflected waves is more complicated because of the sinusoidal variations. These two sine waves, travelling in opposite directions, interact as illustrated in Fig. 128.

(The suffix + is used to indicate the direct, and -, the reflected wave.) Thus v and i , the resultant voltage and current at any point on the line are given by:-

$$v = v_+ + v_-, \quad i = i_+ - i_-.$$

$$\text{At the termination, } (v_-)_r = \rho (v_+)_r$$

$$\text{and } (i_-)_r = \rho (i_+)_r.$$

The phase of v_+ at a distance l from the termination, is advanced on that of $(v_+)_r$ by $\frac{2\pi l}{\lambda}$ radians; whilst the phase of v_- , at the same point, is delayed on that of $(v_-)_r$ by the same amount.

(It is commonly found that these statements are not readily appreciated. What should be clear is that the wave which has travelled farther must be more "stale", since it issued from the generator earlier. The later it issues from the generator, the more recent the phase.)

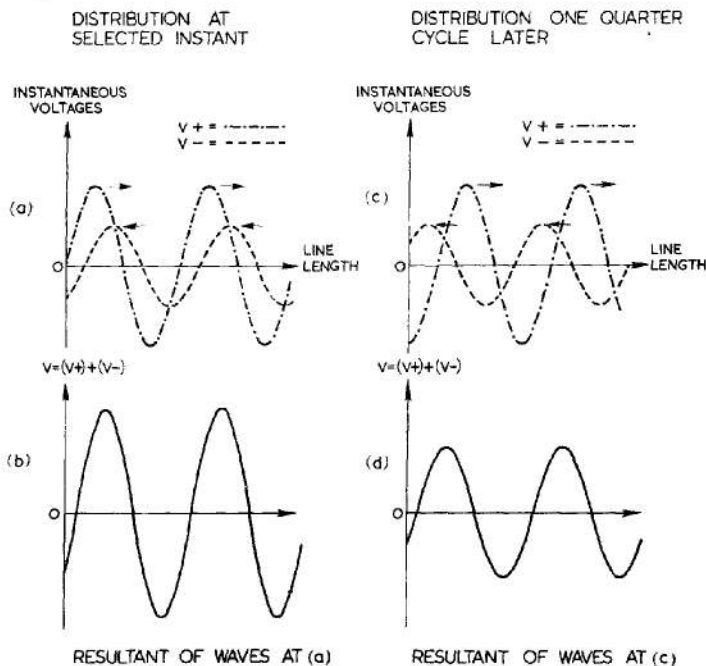

Fig. 128 - Interference between direct and reflected sinusoidal waves.

If the terminating impedance is not a pure resistance there will be a phase difference between $(v_+)_r$ and $(v_-)_r$; in other words, ρ will be complex. In this case

$$\rho = \frac{(v_-)_r}{(v_+)_r} \quad \text{and} \quad |\rho| = \frac{(\hat{v}_-)_r}{(\hat{v}_+)_r} = \frac{\hat{v}_-}{\hat{v}_+},$$

since the amplitudes of the direct and reflected waves are the same at all other points as at the termination, the line being loss-free.

The phase difference between v_+ and v_- will in any case vary with l , the distance from the receiving end, and will increase by 2π as l increases by $\frac{\lambda}{2}$. As l is varied there will be found

points at $\frac{\lambda}{2}$ intervals at which v_+ and v_- are always anti-phase, and

others midway between them at which they are always in phase. The former points are called voltage nodes, and the peak value of the voltage at these points is $\hat{v}_+ - \hat{v}_- = \hat{v}_+ (1 - |\rho|)$.

The intermediate points are called voltage antinodes and the peak voltage there is $\hat{v}_+ + \hat{v}_- = \hat{v}_+ (1 + |\rho|)$.

It may be shown that voltage nodes are current antinodes, and vice versa. At a current node, the peak value is $\hat{i}_+ (1 - |\rho|)$ and at an antinode, $\hat{i}_+ (1 + |\rho|)$.

The ratio $\frac{\text{maximum peak value}}{\text{minimum peak value}}$ for either current or voltage is called the Standing Wave Ratio (SWR). For a loss-free line, the SWR is given by:-

$$S = \frac{\hat{v}_+ + \hat{v}_-}{\hat{v}_+ - \hat{v}_-} = \frac{1 + |\rho|}{1 - |\rho|} = \frac{\hat{i}_+ + \hat{i}_-}{\hat{i}_+ - \hat{i}_-}.$$

This definition will be generalised later to include lossy lines, where there is a SWR for each point of the line (Sec. 24).

At a voltage antinode,

$$\hat{v} = \hat{v}_+ (1 + |\rho|) \quad \text{and} \quad \hat{i} = \hat{i}_+ (1 - |\rho|).$$

At such a point the magnitude of the impedance is a maximum given by:-

$$\begin{aligned} \hat{Z} &= \frac{\hat{v}_+}{\hat{i}_+} \left(\frac{1 + |\rho|}{1 - |\rho|} \right), \\ &= R_0 S. \end{aligned}$$

Hence
$$S = \frac{\hat{Z}}{R_0}.$$

Similarly it may be shown that, at a voltage node, the magnitude of the impedance is a minimum \hat{Z} and that $S = \frac{R_0}{\hat{Z}}$.

At all nodes and antinodes the impedance is purely resistive. Fig. 128 shows how, in the region of interference, the three properties which were found to hold for travelling waves (Sec. 6), are changed fundamentally to become:-

- (i) The amplitude of both voltage and current varies from point to point on the line.
- (ii) The variation of phase with distances is, in general, much more complicated than for travelling waves.
- (iii) The input impedance of the line depends on both the line length and the termination.

It is useful to consider the particular cases of open-circuited and short-circuited lines. It should be noted that the direct wave may always be divided into two parts, one given by $(1 - \rho)v_+$ and the other by ρv_+ . The second part is identical with the reflected wave except in direction of propagation, and the interaction between them is the same as that which follows reflection at an open circuit. Hence the composite wave may be split into a travelling wave $(1 - \rho)v_+$ and what is called a Standing Wave, of amplitude $2|\rho|v_+$, as will be shown in subsequent sections. Energy is transmitted by the travelling wave only, the standing wave storing, and not transmitting, energy.

When the amplitudes of reflected and direct waves are equal ($\rho = \pm 1$) the standing wave produced is sometimes called a Complete Standing Wave. In such a case the voltage and current falls to zero at the respective nodes. Otherwise the distribution may be termed a Partial Standing Wave.

14. Standing Waves on a Uniform Open-Circuited Loss-Free Line

The line distribution of the steady voltage and current at successive intervals is shown in Fig. 129 for a uniform loss-less line terminated in an open circuit. Direct and reflected waves are shown, together with the resultant voltage and current distributions. It will be seen that at even multiples of $\lambda/4$, (multiples of $\frac{\lambda}{2}$) from the termination, the amplitude of the current is zero

and that of the voltage is $2\hat{v}_+$. Similarly at odd multiples of $\frac{\lambda}{4}$

from the termination, the voltage is always zero and the maximum value of the current is $2\hat{i}_+$. The voltages at all points between two consecutive voltage nodes are in phase, and are antiphase with those of the adjoining half-wavelength sections. At any point the current and voltage are in quadrature.

The relation between voltage and current at any point on the line may be determined from the vector diagrams of Fig. 130. The phase of $(v_+)_r$ is taken as the standard phase, and this lags the phase of v_+ , a distance l from the open circuit, by a phase angle β radians where $\beta = \frac{2\pi l}{\lambda}$. Similarly, $(v_-)_r$ leads v_- by the same phase angle.

For $0 < l < \frac{\lambda}{4}$, the phase of the resultant current is shown in the figure (b) to lead that of the voltage in quadrature, i.e., the short section behaves, in the steady state, like a pure capacitance, C_0 , (the equivalent capacitance).

$$\text{where } \frac{1}{\omega C_0} = -X = R_0 \cot \beta.$$

For $\frac{\lambda}{4} < l < \frac{\lambda}{2}$, v leads i in quadrature (c), so that the line

"looks like" a pure inductance L_e where $\omega L_e = X = -R_0 \cot \phi$
 $= R_0 \tan(\phi - \frac{\pi}{2})$.

For larger values of l the effective capacitance and inductance repeat for every additional quarter-wavelength of the line.

The input reactance is given for all values of l by the equation $X = -R_0 \cot \phi$. Its variation with l is shown in Fig. 131.

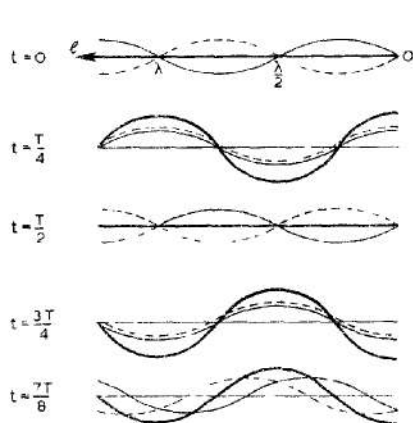

(a) VOLTAGE WAVES ON AN OPEN-CIRCUITED LINE

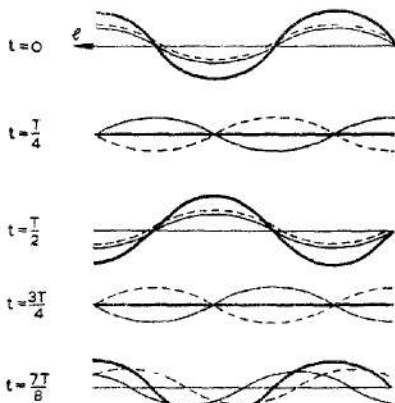

(b) CURRENT WAVES ON AN OPEN-CIRCUITED LINE

--- DIRECT TRAVELLING WAVE
 --- REFLECTED TRAVELLING WAVE
 ——— RESULTANT STANDING WAVE
 l = DISTANCE FROM TERMINATION O

Fig. 129 - Line distribution of voltage and current at successive intervals for uniform open-circuited loss-free line (steady state).

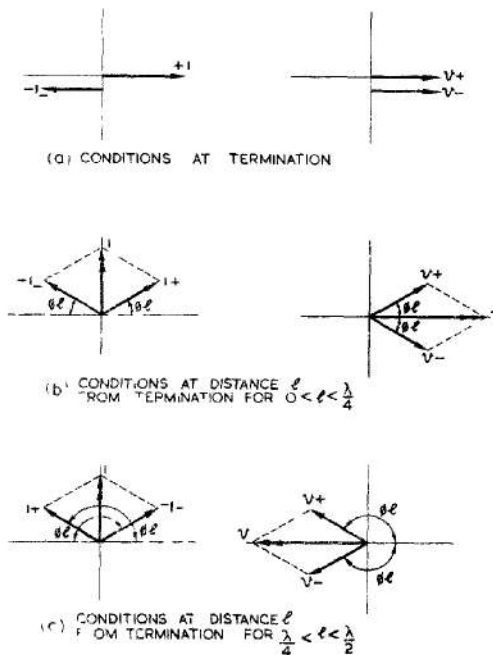

Fig. 130 - Vector diagrams showing relation between voltage and current at various distances from the termination (open-circuited line).

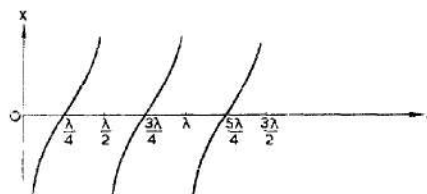

Fig. 131 - Variation of input reactance of open-circuited line with line-length.

15. Standing Waves on a Uniform Short-Circuited Loss-Free Line

The conditions maintained at a short circuit, viz: $v_r = 0$, $\rho = -1$, are the same as those which arise on an open-circuited line at a voltage node, i.e., at odd multiples of $\frac{\lambda}{4}$ from the open circuit.

Since the standing wave distribution for the open-circuit case has already been established, it is convenient to deduce that for the short-circuit case by omitting from the former diagrams the last $\frac{\lambda}{4}$ section of the line.

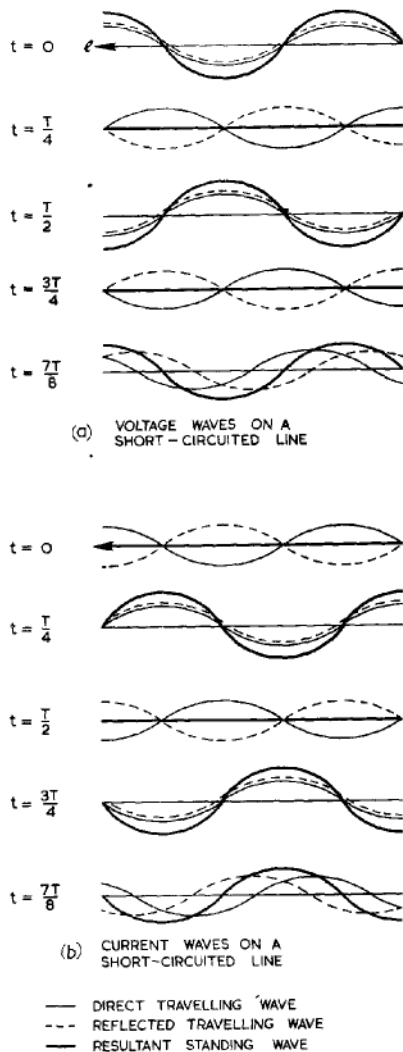

Fig. 132 - Line distribution of voltage and current at successive intervals for uniform short-circuited loss-free line (steady state).

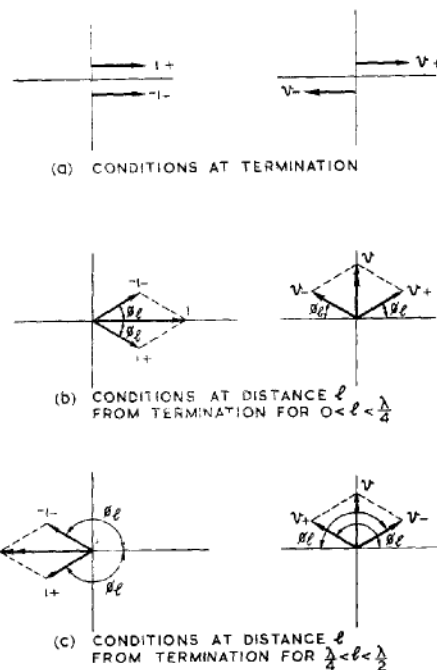

Fig. 133 - Vector diagrams showing relation between voltage and current at various distances from the termination (short-circuited line).

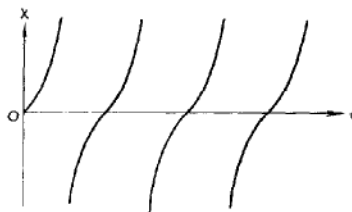

Fig. 134 - Variation of input reactance of a short-circuited line with line-length.

The line distribution thus obtained is shown in Fig. 132, and Fig. 133 gives the vector diagrams showing the relation between voltage and current at the sending end of various lengths of line in the steady state. Fig. 134 gives the variation of input reactance with line length.

Analytically, it will be seen that the two sets of diagrams for the open-circuit and short-circuit cases are mutually interchangeable by substituting voltage in one for current in the other, and vice versa.

It follows that the input susceptance of a short-circuited line of length l is $B = \frac{-1}{R_0} \cot \phi$, so that the input reactance is $X = R_0 \tan \phi$, as shown in Fig. 134.

16. Input Impedance of a Uniform Loss-Free Line for any Termination

For a line of length l and characteristic impedance R_0 , terminated in z_r , it may be shown that the input impedance is:-

$$z_s = R_0 \cdot \frac{z_r + jR_0 \tan \frac{2\pi l}{\lambda}}{R_0 + j z_r \tan \frac{2\pi l}{\lambda}}$$

If z_r is a pure reactance, so is z_s .

If $z_r = R_0$, $z_s = R_0$, as has already been shown.

If z_r is a pure resistance other than R_0 , or is partly reactive, then z_s is in general neither a pure resistance nor a pure reactance.

If z_r is a pure resistance equal to R_r , the input impedance is resistive at all multiples of $\frac{\lambda}{4}$ from the receiving end; the corresponding values of z_s are R_r at multiples of $\frac{\lambda}{2}$ and $\frac{R_0^2}{R_r}$ at odd multiples of $\frac{\lambda}{4}$. For all other lengths of line the magnitude of the impedance lies between these two limits, R_r and $\frac{R_0^2}{R_r}$.

On a loss-free line the input impedance is always resistive at nodes and antinodes, and alternate values have a geometric mean R_0 . Also, at intermediate $\lambda/4$ points the magnitude of the impedance is R_0 .

FUNDAMENTAL LINE CHARACTERISTICS

17. Distributed Elements for a Loss-Free Line

We have shown in Secs. 3 to 6 that if a line is capable of transmitting an electromagnetic wave without loss, it presents a resistive impedance to a generator connected to it. The velocity of propagation is

$$u = \frac{1}{\sqrt{L_l C_l}} \text{ and the value}$$

of the characteristic resistance is $\sqrt{\frac{L_l}{C_l}}$ where L_l and C_l

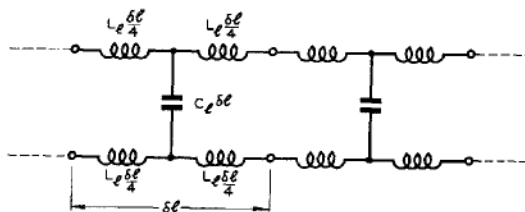

Fig. 135 - Representation of uniform lossless transmission line as an equivalent ladder of infinitesimal filter sections.

C_l are the values of the inductance and capacitance, per unit length, respectively. These results, when compared with those of Chap. 3, Sec. 10, suggest that a line may be represented by an equivalent arrangement of low-pass filter sections in cascade, each section being infinitesimally small. This conception is illustrated in Fig. 135. Each section represents a length δl of the line. Using the results of Chapter 3, Section 10, we have:-

$$f_c = \frac{1}{\pi \delta l \sqrt{L_l C_l}}, \text{ and } z = \sqrt{\frac{L_l}{C_l}} \cos \frac{\delta \beta}{2},$$

where $\sin \frac{\delta \beta}{2} = \frac{f}{f_c}$; $\delta \beta$ being the phase shift for

the section.

As $\delta l \rightarrow 0$, $f_c \rightarrow \infty$, $\delta \beta \rightarrow 0$, $\sin \frac{\delta \beta}{2} \rightarrow 0$ and $\cos \frac{\delta \beta}{2} \rightarrow 1$.

From these results the characteristic properties of transmission lines may be obtained as follows.

Characteristic impedance

$$z_0 = \sqrt{\frac{L_l}{C_l}}, \text{ a pure resistance, } (R_0).$$

Attenuation

Since $f_c \rightarrow \infty$ as $\delta l \rightarrow 0$, the cut-off frequency is infinite and there is no attenuation, but signals at all frequencies are transmitted equally well.

Phase distribution and velocity

Assuming that the phase delay $\delta \beta$ is due to a time delay δt , we may determine $\frac{\partial \beta}{\partial l}$ and $\frac{d l}{d t}$; i.e., the variation of phase with distance along the line at any instant, and the velocity u with which any point of the wave, at which the phase is constant, moves along the line.

From the above relations, it follows that

$$\frac{\partial \beta}{\partial l} = -2\pi f \sqrt{L_l C_l} = -\omega \sqrt{L_l C_l}; \text{ the negative sign indicates that there is a lag in phase as the distance from the generator is increased.}$$

It may be shown that, in the limit, as $\delta l \rightarrow 0$,

$$\frac{\partial \beta}{\partial l} = -\omega \sqrt{L_l C_l};$$

i.e., at any instant the change of phase along a given length of the line is constant and proportional to the length.

In particular, if the change in β is 2π radians the line length over which this occurs is defined as λ , the wavelength, and is given by:-

$$\lambda = \frac{2\pi}{\omega \sqrt{L_l C_l}} = \frac{1}{f \sqrt{L_l C_l}}.$$

u, the phase velocity is given by:-

$$u = \frac{d\ell}{dt} = - \frac{\frac{\partial \ell}{\partial \beta}}{\frac{\partial \ell}{\partial \omega}} = \frac{-\frac{\partial \beta}{\partial \omega}}{\frac{\partial \beta}{\partial \omega}} = - \frac{\omega}{-\omega \sqrt{L_f C_f}} = \frac{1}{\sqrt{L_f C_f}} .$$

It follows that $\lambda = \frac{u}{f}$; i.e. λ is the distance travelled by the wavefront in the time occupied by one cycle at the generator.

Propagation constant

Since there is no change in amplitude but a phase delay $\beta \ell = - \frac{\partial \beta}{\partial \ell} = \frac{2\pi}{\lambda}$ per unit length, the propagation constant γ for a length ℓ of the line may be written

$$\gamma = j\beta = j\beta \ell = j \frac{2\pi \ell}{\lambda} .$$

If $v_s = \hat{v}_s \epsilon^{j\omega t}$ at the generator, the voltage at a point distant ℓ from the generator is given by:-

$$v = v_s \epsilon^{-j \frac{2\pi \ell}{\lambda}} = \hat{v}_s \epsilon^{j(\omega t - \frac{2\pi \ell}{\lambda})} .$$

18. Distributed Elements for a Lossy Line

In general it is impossible to ignore the effect of resistance of the conductors and leakage through the dielectric, and these modify the line characteristics.

Fig. 136 shows the modifications necessary to introduce these quantities into the infinitesimal section of Fig. 135.

Analysis of such a section shows that, on proceeding to the limit as $\delta \ell \rightarrow 0$, the characteristic impedance z_0 , and the propagation constant γ for a line of length ℓ , are given by:-

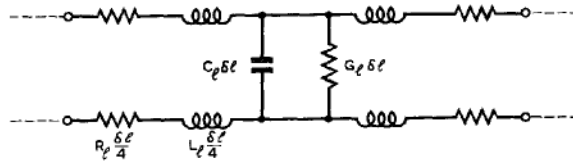

Fig. 136 - Representation of uniform lossy transmission line as an equivalent ladder of infinitesimal filter sections.

$$z_0 = \sqrt{\frac{R_f + j\omega L_f}{G_f + j\omega C_f}} ; \quad \gamma = \ell \sqrt{(R_f + j\omega L_f)(G_f + j\omega C_f)} .$$

We may write $\gamma = \alpha \ell$, where α is the propagation constant per unit length; whence we have that

$$\alpha = \sqrt{(R_f + j\omega L_f)(G_f + j\omega C_f)} = \alpha_f + j\beta_f$$

where α_f is the loss (in nepers) per unit length, and β_f the phase shift (in radians) per unit length.

Since α_l is not in general constant, and β_l is not proportional to frequency, amplitude and phase distortion occur; and unless sinusoidal, the shape of a wave changes as it travels along the line.

Since α_l is not zero, there is attenuation as well as phase shift, energy being dissipated in the conductors (because of R_l) and in the dielectric (because of G_l) as the wave progresses.

19. Characteristic Impedance

$$z_0 = \sqrt{\frac{R_l + j\omega L_l}{G_l + j\omega C_l}}$$

In general, this is complex. In the particular case, where $\frac{L_l}{C_l} = \frac{R_l}{G_l}$, the line is distortionless and z_0 is a pure resistance of magnitude $\sqrt{\frac{L_l}{C_l}}$; but this is not a case commonly encountered in radar. Since line losses are wasteful, every effort is made to reduce them to a minimum. In particular, matching devices become inefficient unless constructed of lines with very low losses.

It may be shown that for open-wire feeders in which conductors each of radius r are spaced with their centres a distance d apart, the characteristic impedance is:-

$$R_0 \approx 276 \cdot \log_{10} \frac{d}{r} \dots\dots\dots(1).$$

The corresponding formula for low-loss coaxial cables is

$$R_0 = 138 \log_{10} \frac{r_2}{r_1} \dots\dots\dots(2),$$

where r_2 is the internal radius of the outer, and r_1 the radius of the inner conductor.

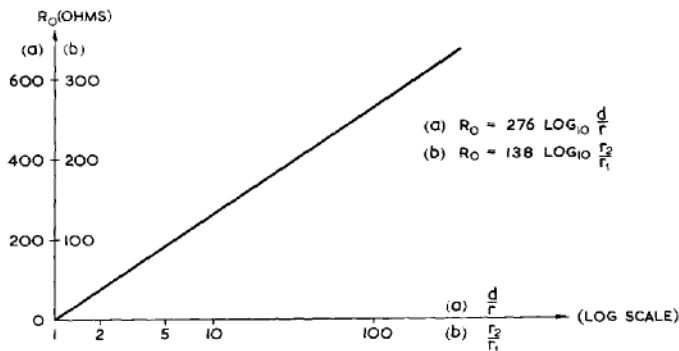

Fig. 137 - Variation of R_0 with frequency for (a) open wire lines, ($d \gg r$), (b) coaxial cables.

These formulae neglect losses, and the former is an approximation which assumes that $d \gg r$. They are illustrated in Fig. 137.

If in the open-wire feeder r is comparable with d the exact formula $R_0 = 120 \cosh^{-1}(d/2r)$ must be used. This is illustrated in Fig. 138.

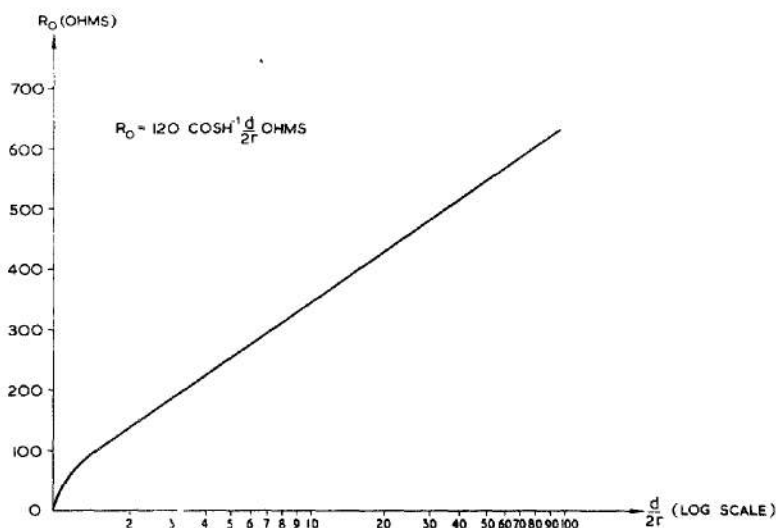

Fig. 138 - Exact relation between R_0 and d/r for open-wire lines formed of twin cylinders.

For conductors embedded in a non-magnetic material of dielectric constant K , the formulae become:-

$$R_0 \approx \frac{276}{\sqrt{K}} \log_{10} \frac{d}{r} \dots\dots\dots(1a)$$

and $R_0 \approx \frac{138}{\sqrt{K}} \log_{10} \frac{r_2}{r_1} \dots\dots\dots(2a)$

20. Propagation Constant

$$\gamma_l = \sqrt{(R_l + j\omega L_l)(G_l + j\omega C_l)} = \alpha_l + j\beta_l$$

In the particular case of the distortionless line, mentioned in Sec. 19, $\alpha_l = \sqrt{R_l/G_l}$ and $\beta_l = \omega \sqrt{L_l C_l}$, and these satisfy the conditions for distortionless transmission; viz: attenuation independent of frequency and phase shift proportional to frequency. This ensures that for a wave of any shape the sinusoidal components of various frequencies are all delayed in transit along the line by the same delay time $T = \frac{\phi}{2\pi f}$, since $\phi \propto f$ (Compare Chap.3, Sec.15).

In the general case, for a wave travelling on an infinite or properly terminated line, the current i at any point may be given in terms of the current i_s at the sending end, by the equation:-

$$i = i_s \epsilon^{-(\alpha_l + j\beta_l)l} \dots\dots\dots$$

If $i_s = \hat{i}_s \epsilon^{j\omega t}$

then, $i = \hat{i}_s \epsilon^{-\alpha_l l} \epsilon^{j(\omega t - \beta_l l)} \dots\dots\dots$

The voltage is obtained from the relation

$$v = i.z_0 \dots\dots\dots$$

The instantaneous values of current and voltage may be written

$$\hat{i}_s \varepsilon^{-\alpha \rho l} \cos(\omega t - \beta \rho l)$$

and
$$\hat{v}_s \varepsilon^{-\alpha \rho l} \cos(\omega t - \beta \rho l + \phi_0),$$

where $\frac{\hat{v}_s}{\hat{i}_s} = Z_0$ (the magnitude of the impedance) and ϕ_0 is the phase angle of the characteristic impedance.

The velocity of propagation is given by:-

$$u = \frac{\omega}{\beta} = \frac{1}{\sqrt{L_l C_l}}$$

For air-spaced conductors, the value of $c = \frac{1}{\sqrt{L_l C_l}}$ may be taken as $3 \cdot 10^8$ metres per second. Since $C_l \propto K$, the velocity of propagation u along transmission lines using a non-magnetic dielectric of constant K is given by:-

$$u = \frac{3 \cdot 10^8}{\sqrt{K}}$$

The factor $\frac{1}{\sqrt{K}}$ is called the velocity constant and is the ratio $\frac{u}{c}$, where u is the velocity in the feeder concerned and c the velocity if the dielectric were replaced by air (or, strictly, vacuum).

21. Vectorial Representation

Fig. 139 shows the difference between the transmission of sinusoidal waves along lossy and loss-free lines, current vectors only being drawn.

For the loss-free line, \vec{v} and \vec{i} are in phase, and both trace out circles. For the lossy line, there is in general a phase difference ϕ_0 between \vec{v} and \vec{i} , and they trace out similar equiangular spirals.

The curves for the loss-free line should be compared with the vectorial representation of the voltages and currents transmitted by a low-pass filter (Fig. 76). They will be seen to be consistent with the idea that the line is the limiting case of an infinite number of infinitesimal low-pass filter sections. With the transition from the polygon to the circle for all frequencies, there is the elimination of the cut-off frequency and the distortion which it introduces.

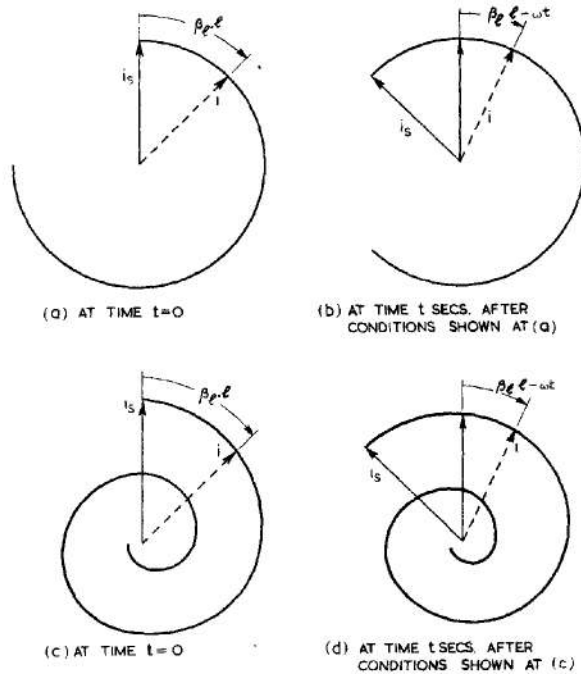

Fig. 139 - Variation of current (or voltage) vectors with line length for loss-free line - (a) and (b) - and lossy line - (c) and (d).

LINES WITH LOW LOSSES

22. Effects on Line Characteristics

If $\frac{\omega L_f}{R_f} \gg 1$ and $\frac{\omega C_f}{G_f} \gg 1$ losses are very small and certain close approximations can be made to the general formulae of Secs. 17 to 21.

The velocity of propagation u is approximately equal to $\frac{1}{\sqrt{L_f C_f}}$ for all frequencies satisfying the above inequalities, the fractional error being approximately $(\frac{R_f}{\omega L_f} + \frac{G_f}{\omega C_f})^2$.

This approximation is justified for all practical purposes in the transmission lines used in radar. It reduces the characteristic impedance z_0 to

$$\sqrt{\frac{L_f}{C_f}} \left\{ 1 + \frac{j}{2} \left(\frac{G_f}{\omega C_f} - \frac{R_f}{\omega L_f} \right) \right\}$$

and it is usually sufficiently accurate to neglect the reactive portion and assume that:-

$$z_0 = \sqrt{\frac{L_f}{C_f}}, \text{ so that it is generally denoted by } R_0.$$

Similarly the loss constant α_l reduces to:-

$$\begin{aligned} & \frac{1}{2} \left\{ R_l \sqrt{\frac{C_l}{L_l}} + G_l \sqrt{\frac{L_l}{C_l}} \right\} \\ & = \frac{1}{2} \left\{ \frac{R_l}{R_0} + G_l R_0 \right\}. \end{aligned}$$

The behaviour of R_l and G_l , and methods of minimising them, are discussed in Sec. 42.

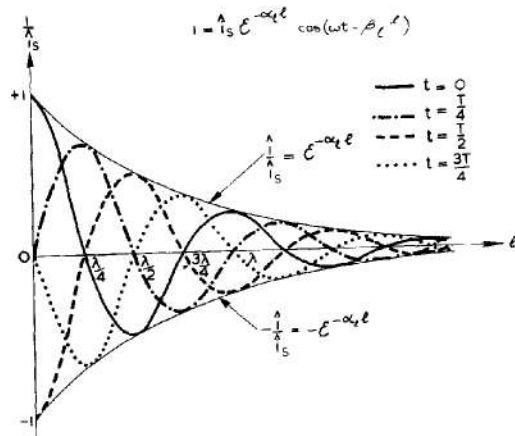

Fig. 140 - Variation of current (or voltage) with distance along the line at selected instants.

23. Effects of Slight Losses on Travelling Waves

Since distortion is usually negligible for the types of line used in radar, the attenuation introduced by low losses is the principal effect to be considered.

The amplitude of a travelling wave decreases as the wave progresses, as illustrated in Figs. 140 and 141(a). This is more simply shown in Fig. 141(b), where the peak values at increasing distances along a lossy line are compared with those for a loss-free line.

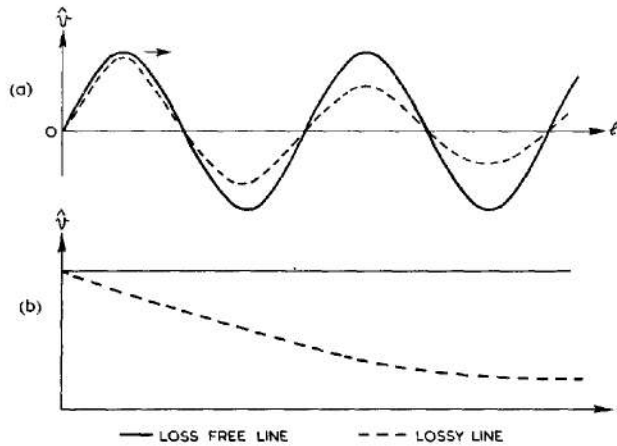

Fig. 141 - Decrease in amplitude of travelling sinusoidal wave due to losses.

24. Effects of Slight Losses on Standing Waves

A simple picture of line conditions can be built up by the method indicated in Figs. 142 and 143. In these figures the attenuation is accentuated to clarify the effects. An open-circuit termination has been chosen. These diagrams will serve also for the short-circuit termination with minor alterations (compare Sec. 15). Other terminations may be considered in the same manner, but as the quantitative results are more complicated, these will be derived analytically where required.

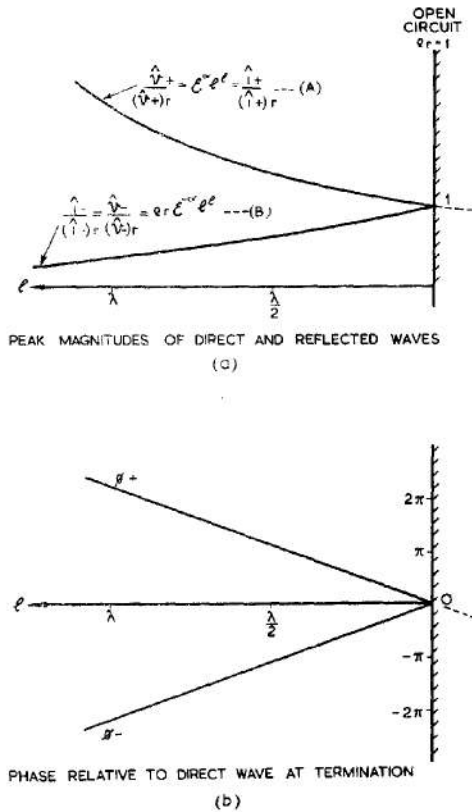

Fig. 142 - Effect of line losses on direct and reflected waves: open-circuited termination.

Because of the reduction in amplitude of the reflected wave compared with the direct wave as the point considered recedes from the termination, the line gives less indication of a mismatch. For very long lines, the amplitude of the reflected wave is negligible compared with that of the direct wave, and the line "looks like" an infinite one, with input impedance R_0 , and standing wave ratio (SWR) unity. In general the SWR at the input is reduced with increase in line length.

Analytically it is convenient to generalise the term Reflection Coefficient to apply to all points on a line, and include the effects of attenuation as well as reflection. If ρ is the reflection coefficient at a distance l from the termination,

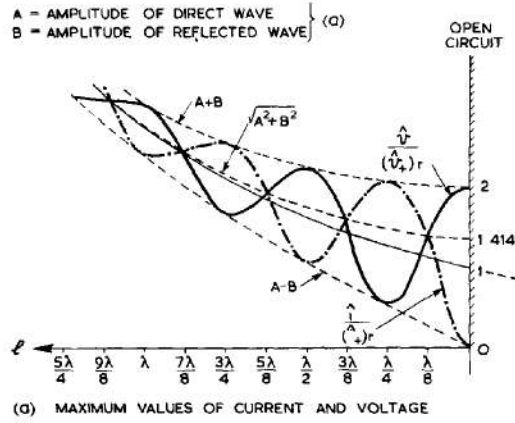
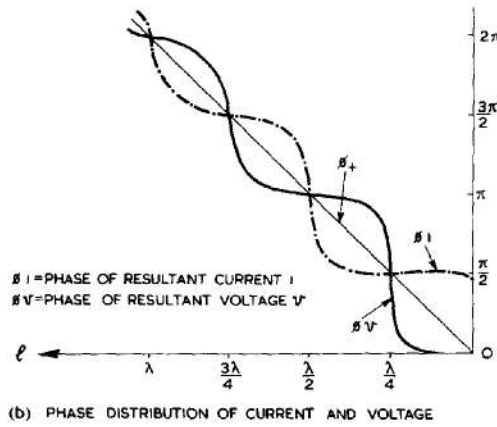

Fig. 143 - Effect of line losses on standing wave; open-circuited termination.



$$\rho = \frac{v_-}{v_+} = \frac{(v_-)_r \epsilon^{-\alpha \rho l} \epsilon^{-j\beta \rho l}}{(v_+)_r \epsilon^{\alpha \rho l} \epsilon^{j\beta \rho l}} = \epsilon^{-2\alpha \rho l} \rho_r \cdot \epsilon^{-2j\beta \rho l}$$

where ρ_r is the value of ρ at the receiving end. (See Sec. 13).

Hence
$$|\rho| = \epsilon^{-2\alpha \rho l} \cdot |\rho_r|$$

At this point the standing wave ratio is given by:-

$$S = \frac{\hat{v}_+ + \hat{v}_-}{\hat{v}_+ - \hat{v}_-} = \frac{1 + |\rho|}{1 - |\rho|} = \frac{1 + \epsilon^{-2\alpha \rho l} |\rho_r|}{1 - \epsilon^{-2\alpha \rho l} |\rho_r|}$$

It follows that as $l \rightarrow \infty, S \rightarrow 1$.

Provided $\alpha \rho$ is small, it is usually sufficiently accurate to take the SWR as equal to the ratio of voltages at an antinode and a node in the neighbourhood of the point considered.

25. Energy Losses

The energy dissipated in the conductor resistance or dielectric conductance is made manifest in the line by the heat generated. This may have subsidiary effects, such as mechanical distortion of the line, and consequent interference with its electrical properties.

The power loss in a low-loss line of length l may be written:-

$$20 \log_{10} \epsilon^{\alpha l} + 10 \log_{10} \left[1 + \frac{(S-1)^2}{4\epsilon} (1 - \epsilon^{-4\alpha l}) \right] \text{ db.}$$

This expression shows the extent to which losses are increased if standing waves are present.

RESONANT LINES

26. General Nature of Resonance in Lines

It follows from the results stated in Secs. 8 - 25 that as the frequency of a signal applied to a short length of transmission line is varied, the line exhibits the properties of series and parallel resonance at specific frequencies. For a uniform loss-less line with an open-circuited termination, the input impedance is either a pure reactance or else is zero or infinite; the variation of this reactance with frequency is illustrated in Fig. 144. The harmonic nature of the resonance characteristics is evident from the figure.

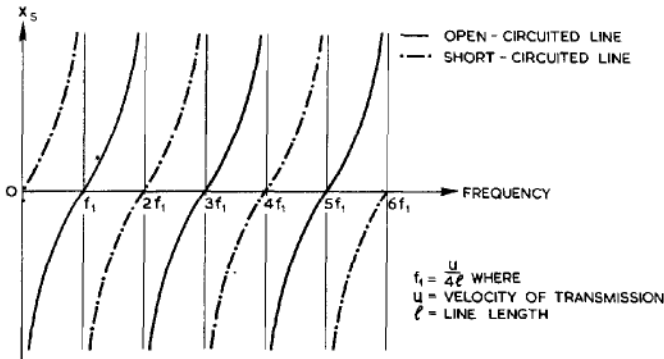

Fig. 144 - Variation of reactance with frequency in loss-free line.

If l is the length of the line, series or parallel resonance occurs, alternately, at all frequencies which are multiples of $\frac{u}{4l}$, where u is the velocity of propagation.

For lines with slight losses, the resonant properties are far more pronounced for shorter lengths; as the line length increases, the input impedance tends more and more to be independent of the line length and to approach R_0 . This is indicated in Fig. 145. Here it is the magnitude of the impedance which is plotted, at a given frequency, for different lengths of line.

A short-circuited line of length l or an open-circuited line of length $2l$ presents a high impedance to a generator of frequency $f = \frac{u}{4l}$, and a reactive impedance to other frequencies.

The impedance is reduced substantially for small deviations of the frequency from resonance. Such a line may be used as a parallel

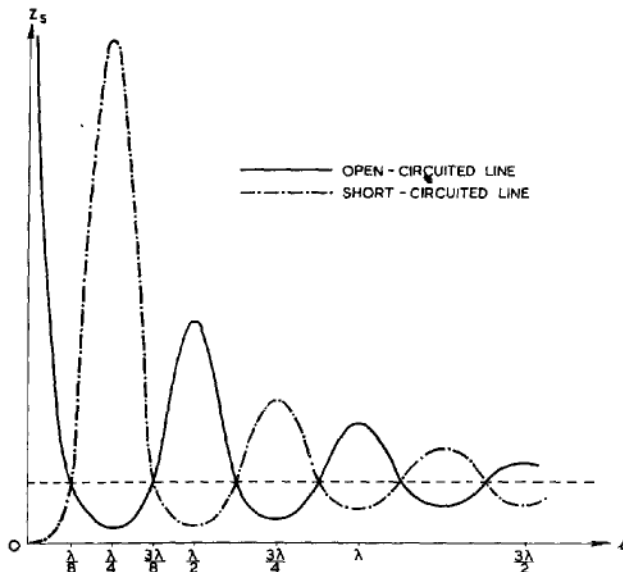

Fig. 145.- Lossy line: variation of magnitude of impedance with line length.

resonant circuit. Similarly, an open-circuited line of length l or a short-circuited line of length $2l$ may be used as a series resonant circuit for a generator of frequency $\frac{v}{4l}$.

For a generator of given frequency f , corresponding to a wavelength $\lambda = \frac{v}{f}$, the resonant lengths are given by the equation

$$l = \frac{m\lambda}{4} \text{ where } m \text{ is an integer.}$$

Non-resonant lines may be used as reactances. The variation of reactance with frequency for open-circuited and short-circuited low-loss lines is illustrated in Fig. 146. In this diagram it is assumed that losses per unit length are independent of frequency.

It should be noted that midway between series and parallel resonant lengths the magnitude of the impedance is always R_0 .

27. Q - Factor of a Resonant Length of Line.

It is known that for a series L - C - R circuit near resonance the magnitude of the impedance is given by $Z = R \sec \phi$ where $\tan \phi = 2Q\delta$, δ being equal to $\frac{f-f_0}{f_0}$, where f is the frequency and f_0 the resonant frequency. (The error in this approximation is of the order $\frac{1}{Q^2}$.) (See Chap. 1, Sec. 19).

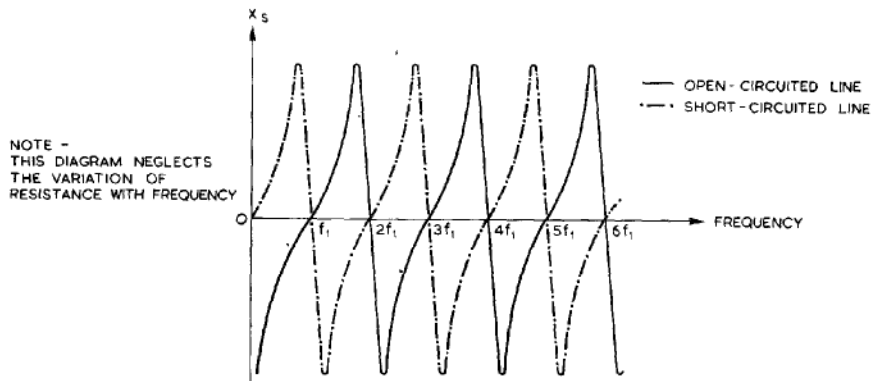

Fig. 146 - Lossy line: variation of input reactance with frequency

It may be shown that for an open-circuited low-loss transmission line, approximately $\frac{\lambda_0}{4}$ in length,

$$Z \doteq (R_0 \frac{\alpha_f \lambda_0}{4} \sec \phi),$$

where $\tan \phi = \frac{2\pi\delta}{\alpha_f \lambda_0}$.

It follows that an open-circuited transmission line of length $\frac{\lambda_0}{4}$ behaves like a series tuned circuit having a Q-factor of magnitude

$$Q = \frac{\pi}{\alpha_f \lambda_0}.$$

This reduces to $Q = \frac{\omega L_f}{R_f}$ if dielectric losses are neglected, corresponding to the Q-factor of a coil in lumped-circuit theory.

Similar results are obtainable for short-circuited lines, a quarter-wave-length line corresponding to a parallel resonant circuit with the same value for Q as for the series circuits. Longer lines, $\frac{\lambda_0}{2}, \frac{3\lambda_0}{4}$, etc., have the same Q-factor as the $\frac{\lambda_0}{4}$ line, but not the same dynamic impedance. The longer the length of line (in quarter wavelengths) the more nearly does the dynamic impedance approach R_0 . For example, a $\frac{\lambda_0}{2}$ short-circuited line has approximately twice the dynamic impedance of a $\frac{\lambda_0}{4}$ open-circuited section of the same line.

In practice very large values of Q may be achieved, of the order 10^4 .

26. Lecher Lines

Short lengths of line may be used as tuned circuits, and are often called Lecher Lines. These are usually short-circuited sections of tubular line, the short-circuit termination providing mechanical rigidity with very low loss.

Fig. 147 shows an arrangement which is suitable for use in a tunable oscillator circuit. The curvature of the lines enables tuning to be performed by a rotary motion, varying the effective length of the lechers. For very high frequencies a self-screening type of tuned circuit is required, as unscreened lines become less efficient as the frequency rises (see Sec. 46). This may take the form of a short length of coaxial line. An arrangement suitable for use in a valve circuit is illustrated in Fig. 148. The line is tuned by moving the plunger which may be fitted with a screw for accurate adjustment.

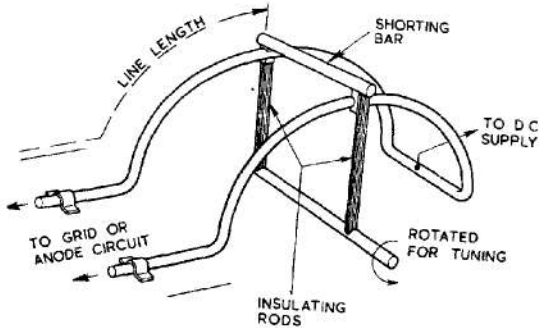
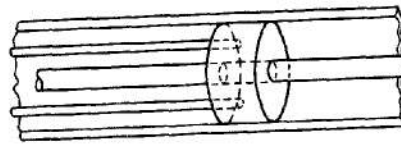

Fig. 147 - Lecher Lines for use in oscillators.

Fig. 148 - Adjustable coaxial short-circuited line with plunger tuning.



29. Metallic Insulators

One of the chief difficulties encountered in the use of open-wire feeders is the maintenance of rigid spacing and positioning of the conductors whilst avoiding high dielectric losses. One method, applicable to a single-frequency transmission system, avoids dielectric losses altogether by the use of what can paradoxically be termed "metallic insulators". The arrangement is illustrated in Fig. 149(a). Such a short-circuited quarter-wave line presents a high impedance to the feeder at the points of junction, and the effect of this on a low impedance line is usually negligible. A frequency variation of $\pm 7.5\%$ is usually permissible before the line becomes appreciably mis-matched.

The problem of supporting the system as a whole does not arise in self-screening lines, such as coaxial systems, where the fields are confined to the inside of the outer conductor and the outside may be earthed at any point without disturbing the electrical properties of the system. But the equivalent problem of supporting the inner conductor may be solved in the same way, by the use of quarter-wave sections of short-circuited line. The arrangement is shown in Fig. 149(b).

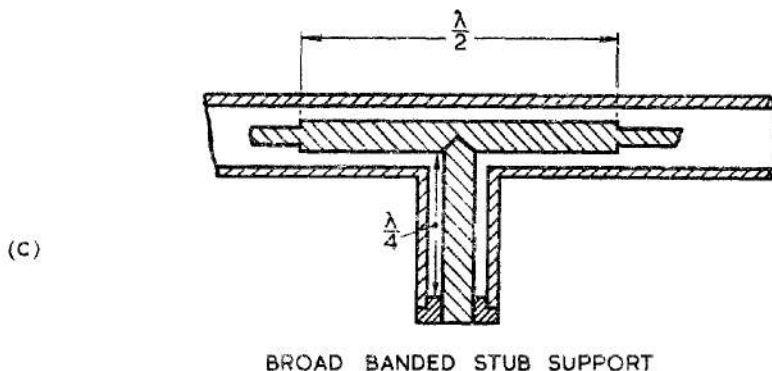
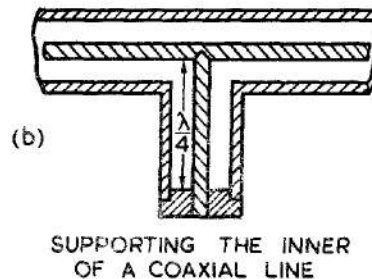
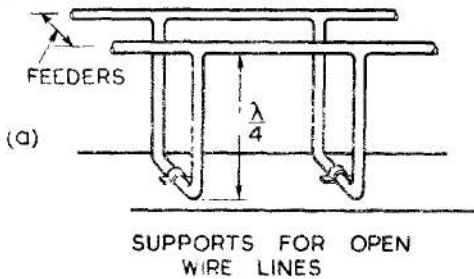

A modification to improve the band width of the insulator is shown in Fig. 149(c). The thickening of the inner conductor forms in effect two $\frac{\lambda}{4}$ transformers back to back, in parallel with the $\frac{\lambda}{4}$ insulator at the junction. The analysis of this arrangement is dealt with in Sec. 54 (viii).

30. Quarter-Wave Sleeve Rejector (Rotating Joint)

This is a method of using a $\frac{\lambda}{4}$ open-circuited coaxial line to join electrically two other sections. Ideally the impedance presented by the device is zero at the frequency of operation.

The arrangement is shown schematically in Fig. 150(a). This represents a $\frac{\lambda}{4}$ section inserted in series with an open-wire feeder. Since the $\frac{\lambda}{4}$ line has zero input impedance it does not affect the flow of energy along the transmission line.

If the figure is rotated about the lower conductor, the upper conductor generates the outer of a coaxial cable, and the $\frac{\lambda}{4}$ line takes the form of a double circular plate of radius $\frac{\lambda}{4}$ with the same properties as in the balanced pair arrangement; this stage is shown in cross-section in Fig. 150(b). If now the protruding $\frac{\lambda}{4}$ "line" is folded back on one of the outers the line presents the appearance of Fig. 150(c). The separate portion AB then becomes redundant, since the outer surface of the cable CB is able to fulfil its functions; when it is removed, the circuit appears as in Fig. 150(d). Finally, the inner may be subjected to the same process as the outer, the complete joint being depicted in Fig. 150(e). Such an arrangement is suitable for a rotating coupling, since there is no mechanical contact to introduce frictional losses.

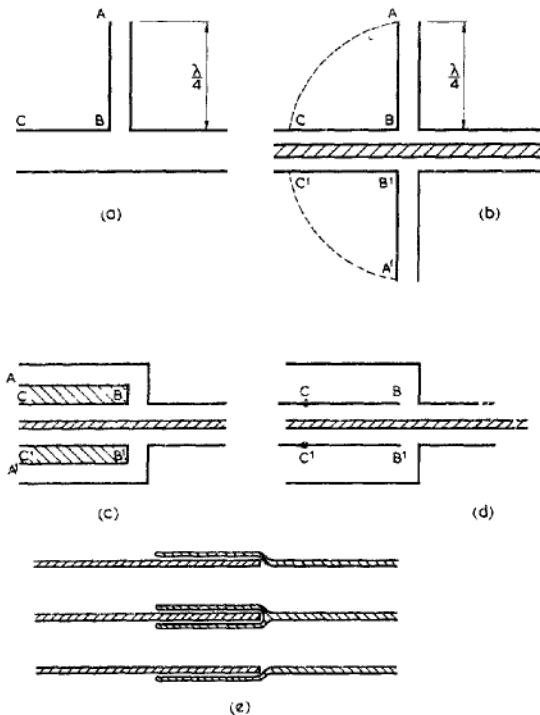

Fig. 150 - Evolution of $\lambda/4$ sleeve rejector (as used in a rotating joint).

31. Stub Reactances

Short (usually $< \frac{\lambda}{2}$) lengths of open-circuited or short-circuited transmission line, used as reactances to modify the standing wave distribution on a transmission system, are called Stubs. Open-circuited stubs are frequently used with open-wire feeders where the conductors are rigid metal tubes or bars. For less rigid structures and for coaxial lines, short-circuited stubs are invariably used.

The variation of input reactance with stub length was given in Figs. 131 and 134. Since the stub is usually connected in parallel with the transmission line it is more usual to analyse stub problems in terms of admittances.

The input admittance of a loss-less short-circuited stub of length l is given by

$$y = -j \cot \frac{2\pi l}{\lambda}, \quad (\text{a short length is inductive}).$$

The input admittance of a loss-less open-circuited stub of length l is given by

$$y = j \tan \frac{2\pi l}{\lambda}, \quad (\text{a short length is capacitive}).$$

MATCHING32. Reasons for Matching

Theoretically it is possible to design a transmission system so that the input and output impedances of all its elements are resistive and of the same value, and matching problems do not arise. However, it is seldom practicable to do this, and more often than not energy is transferred from a generator to an aerial system at several different impedance levels and correspondingly different voltage levels. It has been shown in Secs. 8 to 16 that if a length of transmission line is not terminated in its characteristic impedance standing waves occur on the line, and the input characteristics vary with line length or, alternatively, with frequency. It is inadvisable to have a high standing wave ratio on a long feeder system, since a small change in frequency might cause a large change in input impedance. For example, if a line is 10λ long, a 2.5% variation in frequency would make this 10.25λ or 9.75λ , and this could replace a voltage node at the sending end of the line by a voltage antinode; this would change the input impedance from R_r to $\frac{R_0^2}{R_r}$, or vice versa, which is a variation in impedance equal to the square of the SWR. A similar change of frequency would have relatively little effect if the standing waves were confined to a short matching section less than one wavelength long.

As pointed out in Sec. 25 losses are bound to be heavier if standing waves are present on a feeder system, owing to the extra losses from the oscillatory energy of the standing waves. In addition, losses usually tend to increase with abnormally high voltages and currents, and at antinodes it is possible for dielectric breakdown or corona discharge to occur, with prohibitive loss of energy.

Standing waves on the main portion of a transmission system are avoided by the use of matching sections which fulfil the purpose described in Chap. 3, Sec. 4. They are inserted between source and load and ensure that the transmission lines are terminated in their characteristic impedances. Matching sections may also be used between two lengths of line which have different characteristic

impedances, or to match a feeder system to a generator.

33. Half-Wave Transformer

This is the simplest matching section. It is equivalent to a 1:1 transformer which does not change the input impedance, but transfers the input terminals to a more convenient position. The choice of length, a multiple of $\frac{\lambda}{2}$, enables a line of any convenient characteristic impedance to be used.

If a low-loss line is used, the formula of Sec. 16 can be employed, viz:

$$\frac{z_B}{R_0} = \frac{z_T + j R_0 \tan \frac{2\pi l}{\lambda}}{R_0 + j z_T \tan \frac{2\pi l}{\lambda}}$$

Since l is a multiple of $\frac{\lambda}{2}$, $\tan \frac{2\pi l}{\lambda} = 0$, so that $z_B = z_T$, irrespective of the value of R_0 .

This principle may be employed to join two similar sections of transmission line by a third section of different characteristic impedance. It is the fundamental principle often employed in the construction of plugs and sockets. These usually introduce sections of line of different characteristic impedance, and if their combined length is made a multiple of $\frac{\lambda}{2}$, standing waves on neighbouring sections are avoided.

Typical joints are shown in Fig. 151.

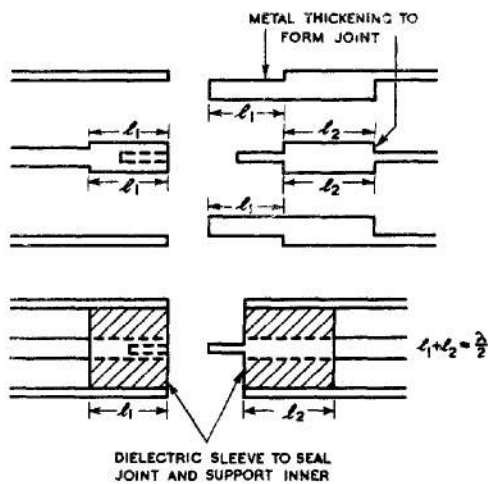

Fig. 151 - Joints designed on the $\frac{\lambda}{2}$ 1:1 transformer principle.

34. Quarter-Wave Matching Sections

These sections of transmission line, odd multiples of $\frac{\lambda}{4}$ in length, are impedance transformers. The formula quoted in Sec. 33 may be written:-

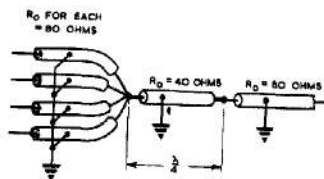

Fig. 152 - Typical matching problem: use of quarter-wave transformer.

$$\frac{z_s}{R_0} = \frac{z_r \cot \frac{2\pi l}{\lambda} + j R_0}{R_0 \cot \frac{2\pi l}{\lambda} + j z_r}.$$

Making the substitution $l = \frac{(2r+1)\lambda}{4}$, we have $\cot \frac{2\pi l}{\lambda} = 0$ and $z_s = \frac{R_0^2}{z_r}$. In the simplest case, where the terminating impedance is resistive (R_r), $z_s = \frac{R_0^2}{R_r}$ and is a pure resistance.

The quarter-wave section thus acts as an impedance transformer. Given two lines of characteristic impedance R_1 and R_2 , a $\frac{\lambda}{4}$ section designed to match the one to the other would need to have a characteristic impedance $R_0 = \sqrt{R_1 R_2}$.

A typical case arises in which a standard cable is to be matched to several similar cables which are in parallel at the junction. This is illustrated in Fig. 152. The four 80 ohm cables present an impedance of 20 ohms; to match this to the single cable requires a $\frac{\lambda}{4}$ section of characteristic impedance $\sqrt{20 \cdot 80} = 40$ ohms.

To preserve the initial spacing of the conductors the matching section either must be made of thicker material, or must use a different dielectric with a larger constant, K .

It may be noted that the use of metallic insulators is the limiting case of a $\frac{\lambda}{4}$ matching section where $z_s = \infty$ and $z_r = 0$.

R_0 may have any value.

35. Double Quarter-Wave Line

The frequency sensitivity of a quarter-wave matching section makes it usable at one frequency only. By extending the principle to the use of two quarter-wave transformers in cascade, with appropriate characteristic impedances, a broad-band match may be obtained.

The characteristic impedances to match R_1 to R_2 should be in the order

$$R_1, \sqrt[3]{R_0}, \sqrt[3]{R_0}, R_2 \quad \text{where:}$$

$$\frac{\sqrt[3]{R_0}}{R_1} = \left(\frac{R_0}{R_1}\right)^2 = \left(\frac{R_2}{\sqrt[3]{R_0}}\right)^2.$$

This relation is more simply expressed in terms of the logarithms of the ratios of consecutive impedances. These ratios for the three junctions are:

$$\frac{\sqrt[3]{R_0}}{R_1}, \frac{\sqrt[3]{R_0}}{\sqrt[3]{R_0}}, \text{ and } \frac{R_2}{\sqrt[3]{R_0}} \quad \text{and the logarithms are in the}$$

ratio 1:2:1.

If ${}_1R_0 = aR_1$, then ${}_2R_0 = a^3R_1$ and $R_2 = a^4R_1$.

Thus, if R_1 and R_2 are given, a may be determined and hence ${}_1R_0$ and ${}_2R_0$.

To a first approximation this arrangement ensures that the reactive term introduced, by a change of frequency, in the output impedance of the first quarter-wave section, is cancelled by an equal and opposite reactive term in the input impedance of the second quarter-wave section.

The output impedance of the first quarter-wave section can be written:-

$$\frac{z_1}{{}_1R_0} = \frac{R_1 \cot \frac{2\pi\ell}{\lambda} + j{}_1R_0}{{}_1R_0 \cot \frac{2\pi\ell}{\lambda} + jR_1}, \quad \text{where } \cot \frac{2\pi\ell}{\lambda} \text{ is small} = x, \text{ say.}$$

(Cot $\frac{2\pi\ell}{\lambda}$ is zero if ℓ is exactly $\frac{\lambda}{4}$.)

We then have
$$\frac{z_1}{aR_1} = \frac{j a R_1 + xR_1}{jR_1 + a xR_1}$$

$$= \frac{a - jx}{1 - ajx} \doteq (a - jx)(1 + ajx) \doteq a + jx(a^2 - 1).$$

So that $z_1 \doteq R_1 a^2 \{ 1 + jx (a^2 - 1) \}.$

Similarly z_2 , the input impedance of the second quarter-wave line can be written

$$\frac{z_2}{{}_2R_0} = \frac{R_2 \cot \frac{2\pi\ell}{\lambda} + j{}_2R_0}{{}_2R_0 \cot \frac{2\pi\ell}{\lambda} + jR_2}$$

and this reduces to $z_2 \doteq R_1 a^2 \{ 1 - jx (a^2 - 1) \}$

This satisfies the matching conditions described in Chap. 3, Sec. 4. An alternative treatment is given in Sec. 54(iv).

The principle of the double quarter-wave line may be extended to any even number of quarter-wave sections, the characteristic impedances being chosen so that the logarithmic ratios at successive junctions form a "binomial coefficient" series, (e.g. 1, 2, 1; 1, 4, 6, 4, 1; etc.) In general an odd number of sections is sensitive to frequency changes; an even number is not. When a large number of sections is used the change in impedance from one end to the other is approximately exponential, and very broad band coverage is afforded.

36. Matching by Stubs

The principle of stub matching is to shunt a section of transmission line by suitable reactances at various points so that the input impedance is made equal to the required value. [Series stubs are not commonly used in transmission line systems.]

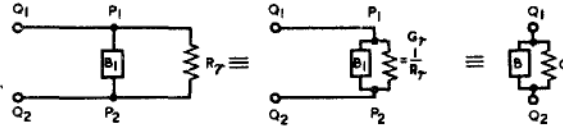

Fig. 153 - Stub reactance in parallel with a matched line.

If a section of correctly terminated line is shunted at some point by a single reactance such as would be presented by a short length of open circuited line, both the input resistance and the input are changed. Fig. 153 illustrates this point. Since we are concerned with parallel circuits it is more convenient to deal in admittances. The section of properly terminated line to the right of $P_1 P_2$ may be replaced by G_T , its characteristic admittance, and the stublength by a susceptance B_1 . As B_1 is varied, the input conductance G and susceptance B are subject to the type of variation indicated in Fig. 154.

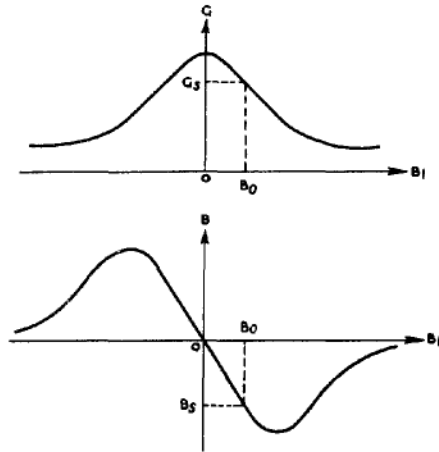

Fig. 154 - Typical variation of B and G with B_1 (see fig. 153).

There is usually a limited range of values over which G varies. If it is required to match the line at $Q_1 Q_2$ to some characteristic admittance G_S such that $G > G_S > G$, it is possible to find at least one value of B_1 , (B_0 , say) for which $G = G_S$; corresponding to this value of B_1 there is an unwanted susceptance B_S . By shunting $Q_1 Q_2$ with an equal and opposite susceptance $-B_S$, the input admittance is made equal to G_S . The schematic appearance of this arrangement is shown in Fig. 155, and the corresponding mechanical design in Fig. 156. This method of matching is known as double stub matching.

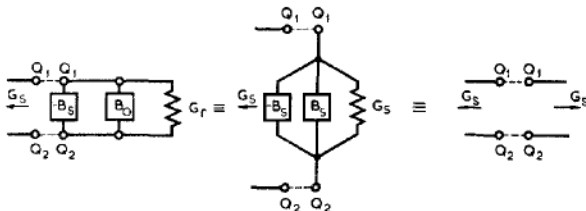
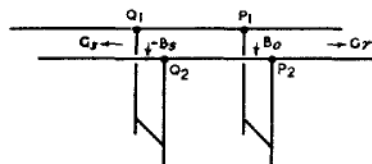

Fig. 155 - Double stub matching: schematic diagram.

Fig. 156 - Arrangement of stubs providing the above matching requirements.



Because of the limited range of values for G it is not possible to obtain a correct match for all values of G_s . There are various methods of overcoming this difficulty. One is to use a third stub. If a match is not possible for one setting of this stub, the setting is changed (usually by approximately $\lambda/4$) and it

it then possible to effect a match using the two other stubs as previously described.

Another method is to change the position of the stubs relative to the two lines. This is indicated in Fig. 157.

The portion P Q R S is made unsymmetrical and reversible so that if a match is not possible with the arrangement as shown in (a), it is possible in the arrangement (b).

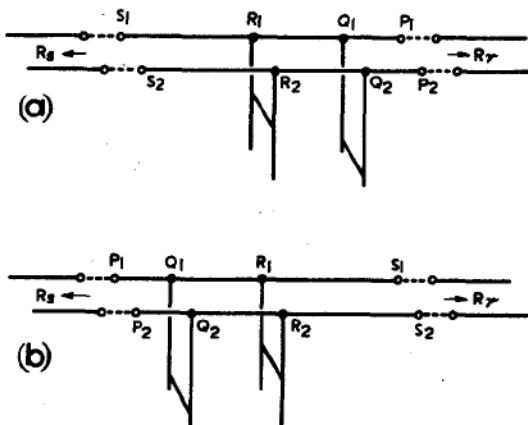

Fig. 157 - Modification to double stub method to extend the matching range.

The single stub method of Fig. 158 is another way of obtaining a match for any relation between source and load impedances. The two variable distances are the stub length l_2 and its distance l_1 from the termination T_1, T_2 . This arrangement is sometimes used with open wire feeders, but it is not readily adaptable to coaxial lines. The disadvantage lies in the mechanical arrangements for the sliding contact. The necessity for robustness makes it difficult to design a sliding contact which does not interfere with the characteristic impedance of the line due to the thickening of the inner conductor caused by the sliding sleeve, as indicated in Fig. 159(a). This does not matter at the short-circuited end of a stub since, on the side remote from the line, there are no restrictions on robustness, as illustrated in (b). Further trouble arises through the necessity for a slot along which the inner conductor of the coaxial stub can move. This is discussed more fully in Sec. 39. Alternatively the same effect as the sliding stub may be created by inserting a line lengthener between the stub and termination; but such an arrangement is not commonly used because it is seldom mechanically convenient and is not without its own sliding joint troubles.

Stub matching is further considered in Sec. 54(v) and (vi).

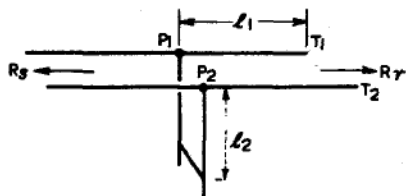
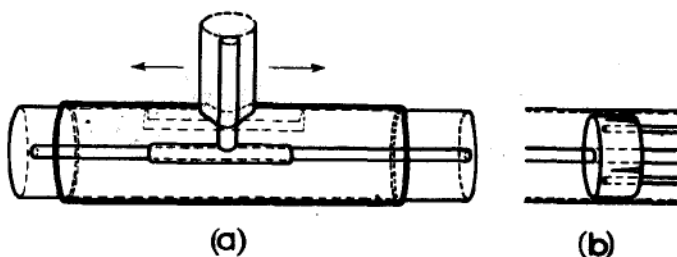

Fig. 158 - Single stub matching arrangement.

Fig. 159 - Sliding joints: movable coaxial stub and plunger.



37. Slugs

Slug is the term used to describe a device which deliberately produces a local variation in the characteristic impedance of a transmission line. In practice, it may take the form of a thickening of one of the conductors of a coaxial cable, or of both conductors of a balanced pair, usually by a movable sleeve. The method is illustrated in Fig. 160. The sleeves may be made either of conducting material or of some dielectric material different from the main dielectric.

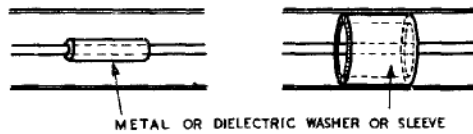

Fig. 160 - Slugs: typical arrangements.

Slugs are usually, but not necessarily, an odd number of quarter-wave-lengths long. In this case they act similarly to the quarter-wave matching sections already described. Movement of the slug along the line provides one degree of freedom for varying the input impedance. As pointed out in Sec. 36, two degrees of freedom in the matching device are required, so that a single slug is not by itself an adequate matching device. Double slug matching is dealt with in Sec. 54(vii).

38. Balance to Unbalance Transformer (Balun)

This term is used to denote a device for matching an unbalanced line to a balanced load or source (see Chap. 3, Sec. 1). Fig. 161 shows an unbalanced line connected to a balanced load R_L . It is clear that if the lower conductor were to be earthed at all points, the lower half of the load would be short-circuited. What is required is a four terminal network, arranged as in Fig. 162, which enables the lower conductor to be earthed but provides the load with a balanced feed.

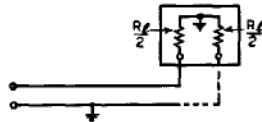

Fig. 161 - Matching unbalanced line to balanced load.

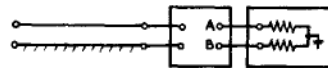

Fig. 162 - Balance to unbalance transformer.

One method uses a series Half-Wave Loop, shown in Fig. 163. The voltage and current at B are equal (neglecting losses) and anti-phase to those at A, which is the condition required for feeding the load in push-pull.

The impedance presented to the line at A E_1 by the rest of the circuit is $\frac{R_L}{2}$, between A and E_2 , in parallel with the input impedance of the half-wave loop. This also is $\frac{R_L}{2}$, since the loop, terminated in $\frac{R_L}{2}$, acts as a 1:1 transformer. Hence the resultant impedance is $\frac{R_L}{4}$ and, to avoid reflection, this should be the characteristic impedance of the main feeder. For single-frequency systems the characteristic impedance of the half-wave loop is immaterial, as shown in Sec. 33.

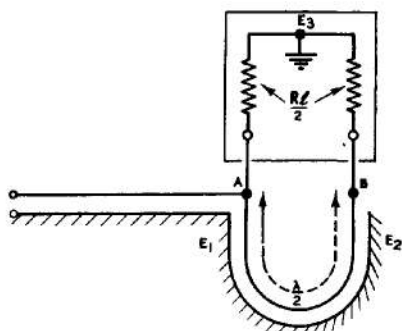

Fig. 163 - Use of half-wave loop.

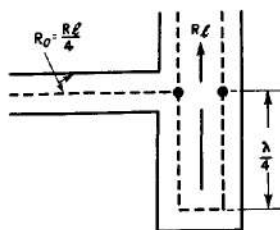

Fig. 164 - Matching coaxial cable to screened pair.

The arrangement of this loop method for coupling a coaxial cable to a screened balanced pair is shown in Fig. 164.

The transformer may be tuned to a required frequency by fitting a variable extension to the loop, as in a trombone. Such an arrangement is sometimes called a "Trombone Matching Section".

Another common method of satisfying the requirements is to use a quarter-wave "can", "skirt" or "balun". The schematic arrangement for an open-wire circuit is shown in Fig. 165. The lower conductor at (a) is earthed at the source, but cannot be at earth potential at all points without short-circuiting the lower half of the load. There is no reason, however, why there should not be a section GC, of the lower conductor, which is at earth potential, while standing waves are present on the remainder, BC, as shown at (B).

Standing wave currents i_3 and i_4 are present on the line as indicated. C is a voltage node of this standing wave system, which exists between BC and earth. There is a similar standing wave between the corresponding portion of the upper conductor and earth, and a current i_1 will flow in the upper conductor due to this standing wave, and an equal and opposite current i_4 will flow between E and D.

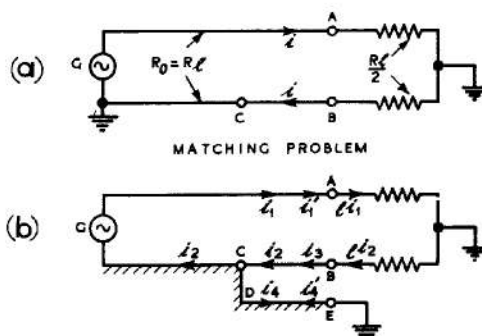

Fig. 165 - Current in standing wave section.

Denoting the travelling wave currents by i_1 and i_2 , as indicated in Fig. 165(b), it follows from elementary circuit theory that

$$i_1 = i_2 \quad \text{and} \quad i_3 = i_4.$$

The value of the current at a particular point is indicated by the use of a prefix; e.g. the currents in the two halves of the load are i_{11} , i_{12} respectively whilst the value of i_3 at B is denoted by i_{B3} .

For equal currents in the two halves of the load, i.e.

$$I^{i_1} = I^{i_2}$$

B^{i_3} must be equal to A^{i_1} .

The coaxial arrangement may be considered as generated by rotating the diagram of Fig. 165 (b) about the upper conductor, to give the arrangement shown in Fig. 166. Provided the main outer cable is a perfect screen, this ensures that there is a very high impedance between the inner conductor and earth, since there is no coupling between the currents in the inner conductor, and outside the outer. The currents corresponding to i_1 and i_4 in Fig. 165(b) are therefore negligible.

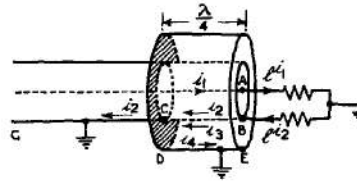

Fig. 166 - Matching can.

It follows that the result deduced above, namely

$$B^{i_3} = A^{i_1}$$

reduces, in the coaxial line, to

$$B^{i_3} = 0.$$

The standing wave between B and C thus has a voltage node at C and a current node at B. Hence BC is an odd number of quarter-wave lengths; usually this is made $\lambda/4$, the outer portion of the can being earthed so that points C and D are at earth potential.

In the coaxial arrangement the currents i_2 and i_3 are separated, flowing in the inner and outer surfaces respectively of the outer conductor BC; i_4 flows in the inner surface of the can DE. The outer surface of the can and the remainder of the cable CG may be earthed everywhere.

In this type of balance-to-ubalance transformer the characteristic impedance of the line should be made equal to the resistance of the load.

The use of a $\lambda/4$ can is especially suited to feeding a half-wave dipole from a coaxial line, as shown in Fig. 167(a). It is preferable to the half-wave loop system, particularly if the aerial is to be "spun", and mechanical symmetry is desirable. An extension of the arrangement for joining a screened balanced pair to a coaxial cable is shown in Fig. 167(b).

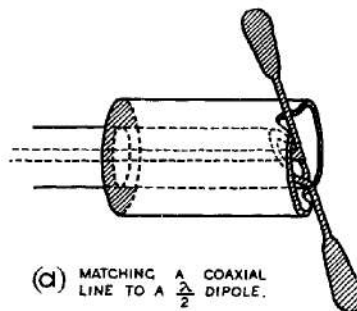

(a) MATCHING A COAXIAL LINE TO A $\lambda/2$ DIPOLE.

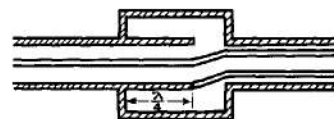

(b) MATCHING COAXIAL CABLE TO SCREENED PAIR

The chief disadvantage of both the transformer systems

Fig. 167 - Matching a coaxial line to (a) $\lambda/2$ dipole and (b) screened pair.

so far described is their sensitivity to frequency changes. A change of frequency causes a mismatch and unbalance in both cases. In the half-wave loop method the input impedance of the loop, terminated in $\frac{R_l}{2}$ is not $\frac{R_l}{2}$ except at the frequency of operation

unless that is its characteristic impedance. In any case, the antiphase relation no longer holds, and a phase mismatch is unavoidable; i.e., the currents in the twin conductors are not antiphase. This changes the input impedance and destroys the correct termination of the coaxial line. In the can method, if the line BC of Fig. 166 is not $\frac{\lambda}{4}$, B is not a current node, so that i_3 is not zero.

This makes i_2 different from i_1 and unbalances the load. Also, the input impedance Z_{in} is not infinite but is reactive and appears in parallel with the lower half of the load resistance, resulting in a mismatch.

It is possible to extend the second method to avoid appreciable unbalance and phase variations at the junction over a wide frequency band.

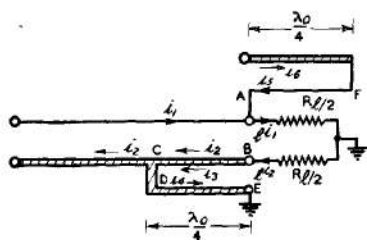

Fig. 168 - Use of $\lambda/4$ stub to remove unbalance in load.

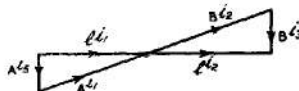

Fig. 169 - Reactive currents (see fig. 168).

A method which permits phase variations but provides a reasonably balanced wide-band transformation is illustrated in Fig. 168. In parallel with the upper half of the load is placed a reactance due to the stub length AF equal to that of DE, in parallel with the lower half, so that the current balance is preserved. This is illustrated in the vector diagram of Fig. 169, the currents referring to those indicated in Fig. 168. The vector relationship indicated implies that the line AF is the same length, and has the same characteristic impedance as the original stub IE.

The actual arrangement is shown in Fig. 170 where a coaxial line is matched to a screened parallel pair. The two stubs AF and BD have the same dimensions, the length $\frac{\lambda_0}{4}$ being the quarter wavelength for the middle of the frequency band over which matching is required. The distance ΔL must be negligible compared with λ_0 .

The Pawsey stub, illustrated in Fig. 171, is based on the same principle as this wide-band matching device, but dispenses with the screening can. The currents flow as indicated in the figure, and correspond to those shown in Fig. 170. The place of the inner surface of the can is taken by neighbouring earthed conductors, carrying the standing wave currents i_4 and i_6 , and if these are remote, the effective impedance will be high, so that the currents i_3 , i_4 , i_5 and i_6 are small. These currents will not, however, be zero, and some radiation is inevitable from the standing wave developed between the stub and the coaxial outer. In practice the short-circuiting plate is adjusted until the best possible match is obtained.

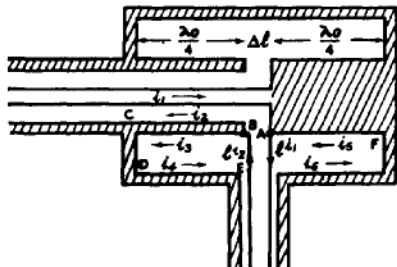
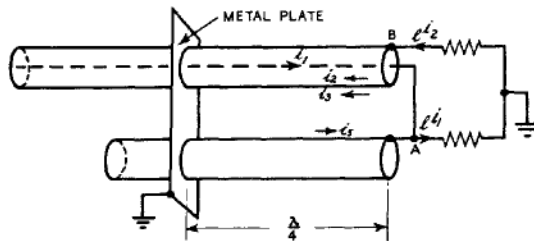

Fig. 170 - Construction of wide-band matching device.

Fig. 171 - Pawsey stub.



Although this method of introducing an auxiliary stub restores the load balance it increases the phase variation since it doubles the susceptance in parallel with the load. This is illustrated in Fig. 172, where X_1 is the input reactance of either of the stubs. Each half of the load is in parallel with jX_1 equivalent to a total reactance in parallel with the load of

$$2X_1 = 2R_1 \tan 2\pi \frac{\lambda_0}{\lambda}$$

when R_1 is the characteristic impedance of either stub.

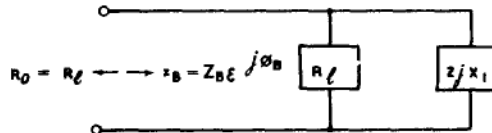

Fig. 172 - Equivalent circuit for wide-band stub match.

The effect of this reactance at various frequencies is shown in Fig. 173 for values $R_0 = 50\Omega$ and $R_1 = 100\Omega$.

If the phase shift of the solid stub method is prohibitive it may be reduced considerably by the use of a further device. This puts in series with the coaxial line a compensating reactance X_2 which neutralizes near the mid-frequency the reactance introduced by the stubs in the previous circuit. X_2 takes the form of an open-circuited stub AH arranged as in Figs. 174 and 175. It does not

interfere with the mid-frequency current distribution of the solid stub method, but changes the matching arrangements as shown in Fig. 176. If R_2 is the characteristic impedance of the compensating stub, the condition for optimum compensation is $R_0^2 = 2R_1 R_2$. Provided $R_1 \gg R_0$, this circuit is an excellent transformer.

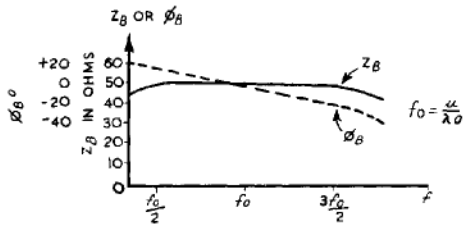

Fig. 173 - Variation of impedance and phase with frequency for wide-band stub match.

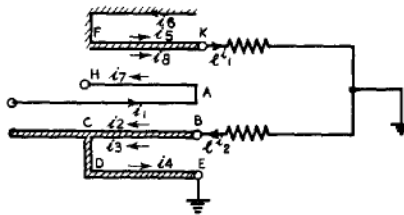

Fig. 174 - Use of auxiliary open-circuited stub as series compensating reactance.

The calculated impedance of a transformer where $R_f = R_0 = 50\Omega$, $R_1 = 100\Omega$ and $R_2 = 12.5\Omega$, is shown in Fig. 177, where the capacitance across Δl is neglected.

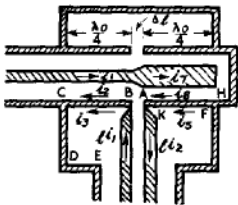

Fig. 175 - Construction of wide-band matching device using compensating open-circuited stub.

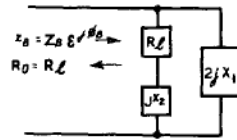

Fig. 176 - Equivalent circuit for fig. 175.

This type of transformer is specially suited for a transfer from a stationary to a rotating member. Since the coaxial line does not make contact with any part of the rest of the system, it can be kept stationary while the whole transformer and balanced two-wire line rotates around it.

39. Standing Wave Indication

If a feeder system is not properly terminated standing waves will occur with the disadvantage described in Sec. 32. To avoid these it is usually essential at UHF

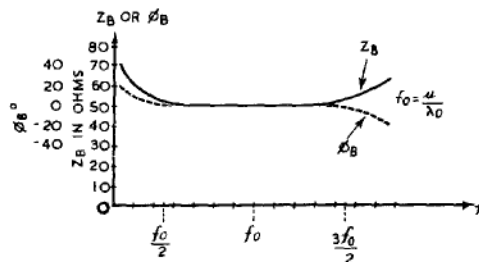

Fig. 177 - Variation of impedance and phase with frequency for wide-band stub match with compensating open-circuited stub.

to use empirical means, since it is not ordinarily possible to coordinate manufacture and design to a degree of accuracy sufficient to ensure the required matching conditions.

Standing wave indicators, which show the variation of field strength with line length, are readily usable with open-wire lines. Coaxial lines introduce considerable difficulties, since it is impossible to measure the field strength inside the cable without making a slot in the outer conductor for the insertion of a probe (or loop). The actual insertion of this probe and its movement along the slot change the line characteristics and increase the difficulty of detecting true standing waves, i.e., those which do not depend for their existence on the presence of the probe or the slot. The same problem exists to a lesser degree in open-wire systems, but usually the presence of a small lightly loaded pickup probe or loop has little effect on the line characteristics. If miniature technique could be sufficiently developed, some improvement might be effected with coaxial or screened lines, but the difficulty is that the smaller the conductors become, the weaker must be the field strength, otherwise there would be a breakdown of the dielectric, or corona discharge. Since at frequencies of the order of 3000 Mc/s and upwards amplification is not yet practicable, the low power available from small pick-ups is the limiting factor in standing wave indication. It is therefore necessary at these frequencies to exercise the greatest care in design to minimise the likelihood of mismatching. The only empirical check practicable is usually an overall one, in which stubs or transformers are adjusted to provide maximum power delivered to the load, usually the aerial system.

The essential feature of a standing wave indicator is a means of estimating field strength. In one of the most elementary forms this is a simple neon lamp, the brightness of which increases with the intensity of the alternating electric field in which it is placed. A more complicated indicator might consist of a pick-up probe or loop coupled to a resonant circuit across which is placed a resonance indicator, such as a valve voltmeter. This is more accurate than the neon indicator, and, since it absorbs but little energy, can be designed to have negligible effect on the line under test. The indicator is moved along the line with a constant disposition relative to the conductors, and the meter or neon shows the increase or decrease in intensity. Matching devices are then adjusted until the standing wave ratio is a minimum.

If the meter is a square-law device, as is often the case, it is the square of the standing wave ratio, or as it is sometimes called, the Power Standing Wave Ratio, which is obtained directly from maximum and minimum readings.

40. Common T/R Circuits

Radar systems which use a common aerial for transmitting and receiving require a special type of transmission system which ensures that the signal energy takes the correct path on each occasion. Two basic circuits, the series and parallel combinations, are depicted in Fig. 178. In both arrangements it is desirable that, to avoid standing waves, the characteristic impedances of the three cables at the junction should have the same value, R_0 .

In the parallel circuit, ideally:-

when transmitting, $z_A = R_0, \quad z_T = R_0, \quad z_R = \infty;$

when receiving, $z_A = R_0, \quad z_T = \infty, \quad z_R = R_0.$

In the series circuit, ideally:-

when transmitting, $z_A = R_0, z_T = R_0, z_R = 0;$
when receiving, $z_A = R_0, z_T = 0, z_R = R_0.$

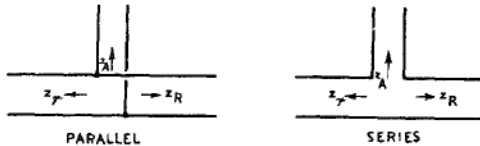

Fig. 178 - Alternative arrangements for common T/R working.

In addition, in the series case the spacing of the lines must not be such as substantially to increase the path lengths of one conductor compared with the other either when transmitting or when receiving. This amounts to the normal requirement that the spacing of the conductors must be small compared with the wavelength.

These changes in impedance must be synchronised with the firing of the transmitter. The change in z_T may be due merely to the transmitter ceasing to operate. If the impedance which it presents at the junction changes from R_0 to either a sufficiently high or a sufficiently low value when oscillations cease, one of the requirements of the basic circuits is thereby automatically satisfied. The other requirement necessitates special provision to change the input impedance to the receiver line.

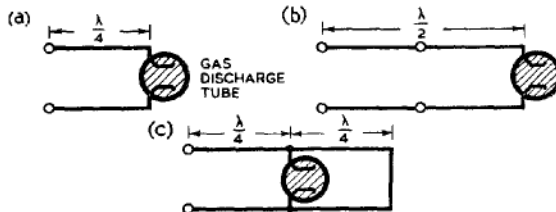

Fig. 179 - Basic switching circuit and modifications.

A basic circuit for providing this change is shown in Fig. 179. A $\frac{\lambda}{4}$ section of transmission line is terminated in a spark gap or other discharge valve. The voltage of the received pulse is quite inadequate for igniting this valve, so that its impedance remains very large during reception. When the transmitter fires, the pulse ignites the valve which then possesses a small impedance, which is maintained by the ionized gases without absorbing further appreciable energy from the pulse. This small terminating impedance makes the input impedance to the $\frac{\lambda}{4}$ line very large.

If an extra $\frac{\lambda}{4}$ line is added to the left of the section, as in Fig. 179(b), the input impedance changes from an open circuit to a short circuit as the transmitter fires, since the line then acts as a $\frac{\lambda}{2}$ section, (1:1 transformer).

It is an advantage to add to the section an extra $\frac{\lambda}{4}$ line, short-circuited at the termination, as shown in Fig. 179(c). This ensures

that before the valve strikes it is positioned at a voltage antinode and is thus more readily ignited by the transmitted pulse.

This arrangement is incorporated as a shunt element in the parallel circuit shown in Fig.180(a) and in the series arrangement of Fig. 180(b). Alternatively a similar arrangement may be used as a series element, as in Figs.180(c) and (d). It is left to the reader to verify that these arrangements satisfy the basic requirements for Fig.178, described at the beginning of this section.

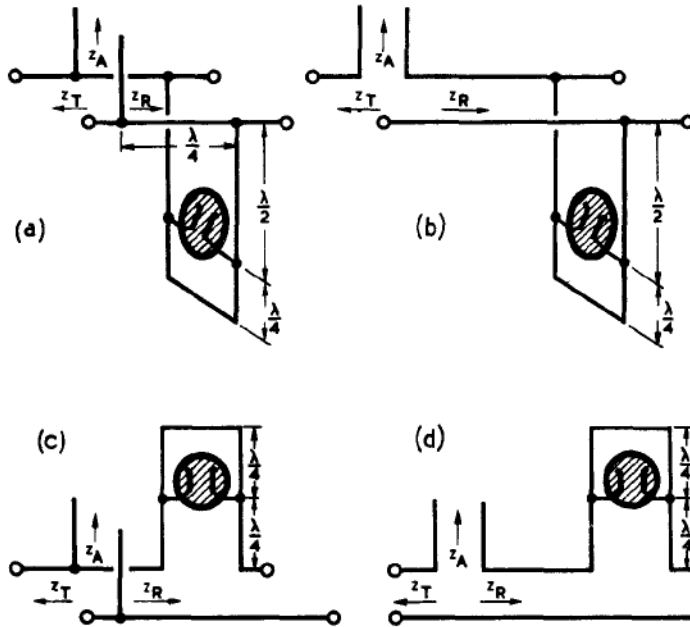

Fig. 180 -
Incorporation of
switching valve in
common T/R circuits.

It should be noted that the $\frac{\lambda}{4}$ or $\frac{\lambda}{2}$ sections fulfil their functions in the steady states only. There is always a build-up time required, during which the wavefront of the transmitter pulse divides at the junction and part is carried to the aerial, part to the switching valve section in the receiver lead, and part is reflected because of the temporary mismatch. This transient period will occupy a number of cycles, but forms only a negligible fraction of the pulse width, provided a sufficiently high frequency is employed.

It is common to use more than one valve or other switching device, at different points on the receiver feeder, as it is more reliable to use several relatively simple switches rather than to attempt to provide a sufficient degree of reliability with a single switch.

Where it is not possible to rely upon the change in output impedance of the transmitter to provide the necessary switching in that branch of the circuit, an additional switching circuit is necessary. Alternative arrangements are shown in Fig. 181. In the parallel case (a) or (c), the input impedance z_T changes from an open circuit, its value when the transmitter is not pulsing and the valve is open, to R_0 when the transmitter fires and closes the valve. In the series case (b) or (d) z_T changes from a short-circuit to R_0 as the transmitter fires.

Neon valves and open or enclosed spark gaps may be used as switching valves with open-wire lines. Open spark gaps may or may not be "blown", and a "keep-alive" electrode, although sometimes desirable, is not always necessary (See Chapter 6).

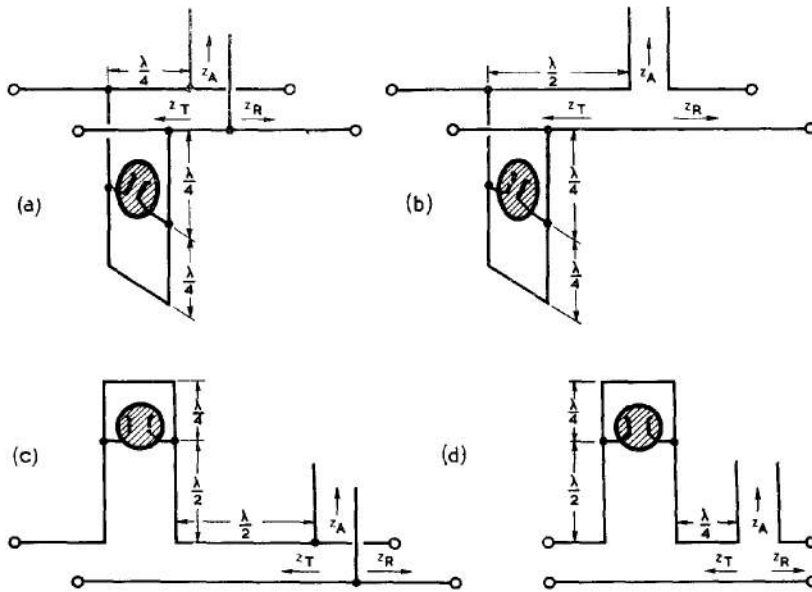

Fig. 181 - Alternative arrangements for switching the transmitter branch of the feeder system.

In the adaptation of this technique to coaxial lines or wave guides a soft rhumbatron is commonly used as a switching device. The valve may be inserted in series with the receiver lead, as shown in Fig. 182(a); the equivalent circuit is shown at (b). The input impedance of this valve is normally resistive and of magnitude R_0 , the rhumbatron acting as a transformer which is adjusted by the positioning of the current loops. When the transmitter fires, the gases in the valve ionize and this condition corresponds to short-circuiting the secondary circuit between A and B. The input impedance becomes small and almost purely reactive. It is this change in input impedance that fulfils the function of the switching valve.

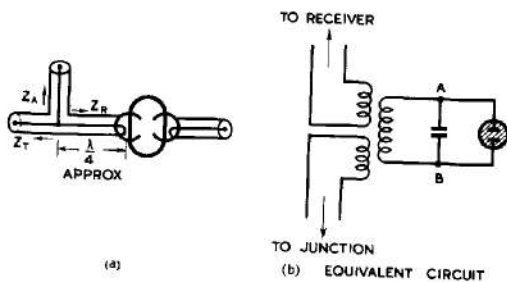

Fig. 182 - Use of soft rhumbatron as switching valve.

Fig. 183 - Simple but inefficient system which relies on change in transmitter impedance.



$R_T = p R_T$ WHEN THE TRANSMITTER IS PULSING.
 $R_T = o R_T$ WHEN THE TRANSMITTER IS QUIESCENT

A very simple but inefficient common T/R system can operate without any switching valves, relying entirely on the change in output impedance of the transmitter and allowing considerable mismatching on reception. This may be illustrated with reference to Fig. 183.

If P_{R_T} is the input resistance of the transmitter branch of the feeder system at the junction when the transmitter is pulsing, and Q_{R_T} when it is quiescent, the following relations should be satisfied.

- (i) $P_{R_T} = R_A + R_R$, and $R_A \gg R_R$; this ensures that on transmission, most of the energy goes to the aerial, and that the system is then properly matched.
- (ii) $R_R \gg Q_{R_T}$; this ensures that on reception most of the energy goes to the receiver. However, the previous requirement, $R_A \gg R_R$, implies that a mismatch on receiving is inevitable.

The overall requirements are:-

$$P_{R_T} > R_A \gg R_R \gg Q_{R_T}.$$

The corresponding relations for the parallel circuit of Fig. 178 are obtained by reversing the inequalities throughout; viz;

$$P_{R_T} < R_A \ll R_R \ll Q_{R_T}.$$

LIMITATIONS OF TRANSMISSION LINES

41. Resistive and Dielectric Losses

It was stated in Sec. 18 that the propagation constant per unit length of a transmission line may be written

$$\begin{aligned} \gamma_l &= \sqrt{(R_l + j\omega L_l)(G_l + j\omega C_l)} \\ &= \alpha_l + j\beta_l, \end{aligned}$$

where α_l is the loss in nepers per unit length. In Sec. 22 it was further stated that when $\frac{\omega L_l}{R_l} \gg 1$ and $\frac{\omega C_l}{G_l} \gg 1$ it is usually sufficiently accurate to take the loss in nepers as

$$\begin{aligned} \alpha_l &= \frac{1}{2} \left(\frac{R_l}{R_0} + G_l R_0 \right) \\ &= \alpha_c + \alpha_d, \end{aligned}$$

where $\alpha_c = \frac{R_l}{2R_0}$, and is the loss attributable to the finite conductivity of the conductors, and $\alpha_d = \frac{G_l R_0}{2}$, representing the dielectric loss factor.

42. Resistive Losses

For a parallel pair, of radius r and separation d , the value of R_l may be written as

$$R_l \doteq \frac{2}{r} \sqrt{\frac{\mu f}{\sigma}}$$

provided $d \gg r$,

μ being the permeability and σ the conductivity of the metal, and f the frequency.

For a coaxial cable of inner radius r_1 and outer r_2 ,

$$R_f \doteq \sqrt{f} \left\{ \frac{1}{r_1} \sqrt{\frac{\mu_1}{\sigma_1}} + \frac{1}{r_2} \sqrt{\frac{\mu_2}{\sigma_2}} \right\}, \text{ where the suffixes 1}$$

and 2 correspond to the inner and outer conductors respectively.

Using the formula for R_0 given in Section 18, we may write:-

$$\begin{aligned} \alpha_c &= \frac{R_f}{2R_0} \\ &= \frac{\sqrt{f}}{\frac{138}{\sqrt{K}} \log_{10} \left(\frac{r_2}{r_1} \right)} \left(\frac{1}{r_1} \sqrt{\frac{\mu_1}{\sigma_1}} + \frac{1}{r_2} \sqrt{\frac{\mu_2}{\sigma_2}} \right) \end{aligned}$$

In the particular case where $\mu_1 = \mu_2, \sigma_1 = \sigma_2$,

$$\alpha_c = \frac{1}{138} \sqrt{\frac{K\mu f}{\sigma}} \left(\frac{1}{r_1} + \frac{1}{r_2} \right) \log_{10} \left(\frac{r_2}{r_1} \right)$$

From these results we may conclude that for both balanced-pair and coaxial lines:-

- (i) $\alpha_c \propto \sqrt{f}$.
- (ii) for a given R_0 (i.e., a fixed ratio $\frac{r_2}{r_1}$ or $\frac{d}{r}$), α_c is reduced by increasing the size of the conductors.
- (iii) α_c is reduced by using metals with high conductivity and low permeability.

Further results applicable to coaxial cables only are:-

- (iv) There is an optimum value of $\frac{r_2}{r_1}$ which depends on the conditions imposed on the variation of r_1 and r_2 .

Viz. For minimum resistive losses with a constant value for r_2 , $\frac{r_2}{r_1}$ should be 3.6.

For maximum dielectric strength, giving the least chance of a breakdown, $\frac{r_2}{r_1}$ should be 2.72.

- (v) When the conductivities do not have to be equal, the higher conductivity should be given to the inner conductor.

Results applicable to balanced-pair lines only are:-

- (vi) For minimum resistive losses with a constant value for d , $\frac{d}{r}$ should be approximately 4.

For maximum dielectric strength the optimum ratio is approximately $\frac{d}{r} = 5.4$.

43. Dielectric Losses

The power factor F of a dielectric is equal to $\cos \phi$, where $\tan \phi = \frac{\omega C_f}{G_f}$. Since we are concerned with low losses only, we may take

$$\omega C_f \gg G_f$$

$$\text{so that } F \doteq \cot \phi = \frac{G_f}{\omega C_f}.$$

$$\text{Hence } G_f \doteq \omega C_f F.$$

Substituting this in the expression for α_d given in Sec. 41, we have

$$\begin{aligned} \alpha_d &\doteq \frac{\omega C_f}{2} R_0 \doteq \frac{\omega F \sqrt{L_f C_f}}{2}, \quad \text{since } R_0 \doteq \sqrt{\frac{L_f}{C_f}} \\ &\doteq \frac{2\pi f F}{2u} \\ &\doteq \frac{\pi f F}{u}, \quad \text{where } u \text{ is the velocity of propagation} \end{aligned}$$

in the dielectric.

44. Frequency Effects

Since resistive losses are proportional to \sqrt{f} , and dielectric losses to f , it follows that the former predominate at low, and the latter at high, frequencies. Cables are normally used below the frequency at which dielectric and resistive losses are equal.

45. Coaxial Cables with Low Losses

Cables with the lowest attenuation are those with air as dielectric. The central conductor should be rigidly supported on insulating spacers of low-loss material (e.g., distrene) in order to preserve the characteristic properties of the cable. Such a cable is usually inflexible. Flexible cables require some dielectric filling to support the inner conductor and to keep it central, and a dielectric should be employed, if one exists, such that α_d is less than α_c at the operating frequency.

The radius r_1 , of the inner conductor should be chosen as large as possible consistent with flexibility, and the outer should be given a radius $r_2 = 3.6r_1$, (approximately).

For a solid copper inner conductor a typical value of the diameter is 0.056 inches, with 0.33 inches for the outer. With dielectric constant 2.3, the characteristic impedance would be $R_0 = 75$ ohms. To increase the effective radius of the inner while retaining flexibility, a stranded inner is sometimes employed. This procedure is successful at the lower frequencies, but at higher frequencies stranding increases the loss in the inner. It is important to protect the outer conductor, which is often braided for flexibility, from corrosion, which increases the loss and causes the cable to exhibit inconsistent electrical behaviour. Protection is afforded usually by an outer sheath of polyvinyl chloride or by a coating of enamel. Where a braided outer conductor is used the paths of the currents along the strands of the braid are oblique to the axis, and are effectively lengthened so that the loss in the outer is somewhat increased.

46. Other Losses in Open-wire Feeders

The effect of weather on open-wire lines may be serious if the line is several wavelengths long. Damp on insulators and spacers may considerably alter line characteristics and cause standing waves to develop. It is possible to minimise these effects by using conductors stretched between fixed end supports rather than supported at intervals along the line; and these supports should be of the metal insulator type.

Losses occur at frequencies at which the spacing between the conductors is comparable with the wavelength. If there are discontinuities in the line (and at either the beginning or the end some form of discontinuity is inevitable) radiation losses occur. But in any case, the existence of comparatively large induction fields at points near the line may cause considerable loss due to pickup in neighbouring conductors. These conductors may dissipate the energy in the form of heat or, which is usually even more undesirable, radiate electromagnetic energy which would interfere with the directivity of the main aerial system.

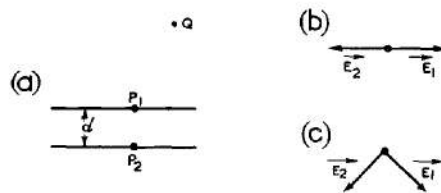

Fig. 184 - Resultant fields due to alternating currents when d is comparable with λ .

The manner in which these fields occur is shown in Fig. 184. The vector \vec{E}_1 represents the time-variable electric field at Q due to the current in a small element of the line at P_1 , and \vec{E}_2 that due to the corresponding element at P_2 . These currents are in opposition, so that, provided Q is equidistant from P_1 and P_2 , the equal vectors \vec{E}_1 and \vec{E}_2 will be antiphase and the resultant vector will be of negligible magnitude.

This will be true for all positions of Q provided P_1 and P_2 are separated by $d \ll \lambda$, as for the case (b). Where d is not small compared with λ , there will be positions of Q for which the difference in pathlengths $P_1 Q$ and $P_2 Q$ causes an appreciable phase difference in \vec{E}_1 and \vec{E}_2 at Q as at (c). There is thus a resultant vector, whose magnitude is not negligible, at points several wavelengths from the conductors. This normally represents the induction field, but at discontinuities in the conductors the same applies to the radiation field; [for a consideration of these different fields see BR 229 Sec. R para. 7 or AP 1093 Chap. VII para. 31.]

In general, more energy is stored in the electric and magnetic fields at regions further from the conductors and more extraneous radiation of energy occurs as the frequency is raised.

A short length of transmission line improperly terminated may be used as an aerial because of this fact. Some microwave oscillators have open-circuited lines built into the valve-circuits inside the envelope and these fulfil the dual role of resonant circuits and radiators. They may be inserted in waveguides without external connections, energy being radiated direct from the standing wave system on the open-circuited line.

CIRCLE DIAGRAMS47. Introduction

In Sec. 16 an analytical expression was given for the input impedance of a uniform lossless line of characteristic impedance R_0 terminated in any impedance z_r . Practical problems requiring the use of such relationships in successive applications give rise to complicated arithmetical manipulations which make the analytical method of solution tedious and which mask the physical significance of the processes employed. A geometrical method of tackling such problems involving the use of Circle Diagrams gives results which are sufficiently accurate for most practical work, and are speedily obtainable with a little practice and familiarity with the method. Also the pictorial representation involved in this method helps to keep the physical principles in mind, since movement from one part of a line to another is represented by a particular type of movement from one part of the diagram to another. The subsequent sections are devoted to a description of the Circle Diagram or Transmission Line Calculator and the methods by which it may be used in the solution of transmission line (and waveguide) problems. By this means some of the problems already dealt with qualitatively can be given a quantitative interpretation.

We make no attempt to discuss the theory of circle diagrams but merely show how they can be employed to solve transmission line problems. Further, although two forms of circle diagrams are in common use, the Cartesian and the Polar, we shall here limit ourselves to a description of the former alone.

48. Normalised Impedances and Admittances

The fundamental formula of Section 16,

$$z_s = R_0 \frac{z_r + j R_0 \tan \phi}{R_0 + j z_r \tan \phi}, \quad (\phi = \frac{2\pi \ell}{\lambda})$$

may be written in the form:

$$\frac{z_s}{R_0} = \frac{\frac{z_r}{R_0} + j \tan \phi}{1 + j \frac{z_r}{R_0} \tan \phi}$$

If we now replace $\frac{z_s}{R_0}$ and $\frac{z_r}{R_0}$ by $\boxed{z_s}$ and $\boxed{z_r}$ respectively, we have

$$\boxed{z_s} = \frac{\boxed{z_r} + j \tan \phi}{1 + j \boxed{z_r} \tan \phi},$$

so that the formula connecting $\boxed{z_s}$ and $\boxed{z_r}$ depends only on $\frac{\ell}{\lambda}$ and not on R_0 .

The ratio $\boxed{z} = \frac{z}{R_0}$ is called a Normalised Impedance, and is dimensionless.

Similarly, $\boxed{y} = \frac{y}{G_0}$ is called a Normalised Admittance;

$$(G_0 = \frac{1}{R_0}).$$

* In diagrams, italics are used to denote normalised impedances and admittances.

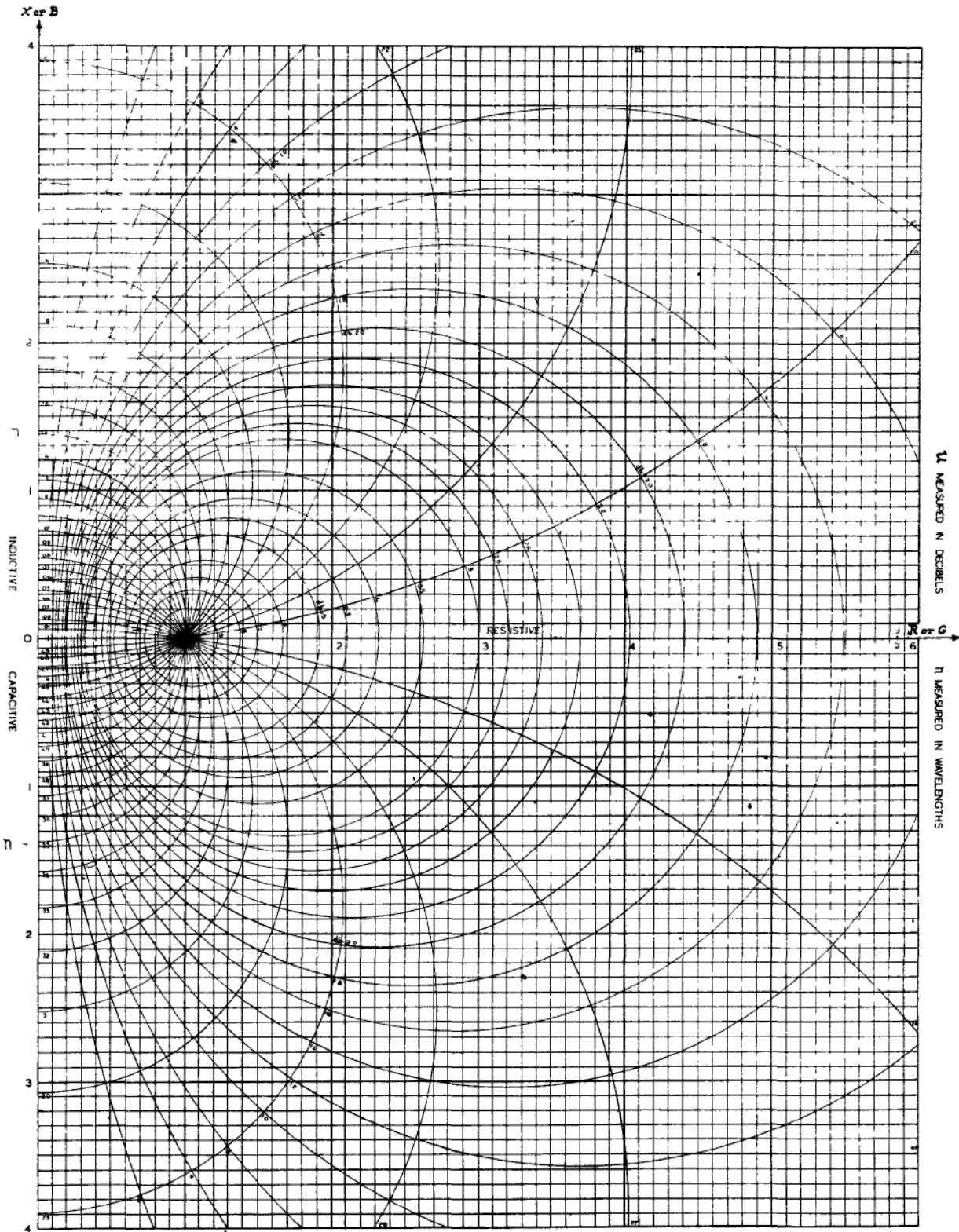

Fig. 185. Circle diagram.

Clearly,

$$\begin{aligned} \boxed{y} &= \frac{y}{G_0} \\ &= \frac{R_0}{z} \\ &= \frac{1}{\boxed{z}} \end{aligned}$$

so that the reciprocal relation between admittance and impedance holds also for their normalised equivalences.

The use of normalised impedances and admittances makes it possible to use the same system of co-ordinates for all circle diagrams applied to any uniform loss-less line. Also, the same

normalised quantity \boxed{z} or \boxed{y} may be taken to represent either an impedance or an admittance (normalised) since both are dimensionless.

If $z = R + jX$,

then $\boxed{z} = \boxed{R} + j \boxed{X}$, where \boxed{R} and \boxed{X} are the normalised resistance and reactance respectively, given by

$$\boxed{R} = \frac{R}{R_0} \quad \text{and} \quad \boxed{X} = \frac{X}{R_0}.$$

Similarly, if $y = G + jB$,

then $\boxed{y} = \boxed{G} + j \boxed{B}$, where $\boxed{G} = \frac{G}{G_0}$ and $\boxed{B} = \frac{B}{G_0}$.

49. The Cartesian Circle Diagram

Fig. 185 is an example of a Cartesian Circle Diagram. It comprises a Cartesian system of axes as a background which is indicated separately in Fig.186(a). When working with circle diagrams, impedances and admittances must first be reduced to their normalised forms

$$\boxed{z} = z/R_0 \quad \text{and} \quad \boxed{y} = y/G_0.$$

An impedance $\boxed{z_1} = \boxed{R_1} + j\boxed{X_1}$ is represented on the diagram by the point P $\boxed{R_1}$, $\boxed{X_1}$ whose co-ordinates are $\boxed{R_1}$ and $\boxed{X_1}$ as shown.

The impedance \boxed{z} can be regarded as being represented either by the point P or by the vector \vec{OP} . In the same way an admittance $\boxed{y_1} = \boxed{G_1} + j\boxed{B_1}$ is represented by the vector \vec{OQ} or by the point Q (Fig. 186(a)).

Superimposed on the Cartesian reference system is a family of complete circles, the u-circles, and another family of circular arcs, the n-arcs, that cut the u-circles at right angles. It is not necessary to understand the theory and construction of the diagram in order to use it, but for interest some properties of the

The circle $u = 0$ is therefore the same as the $\pm j\boxed{X}$ ($\pm j\boxed{B}$) axis.

At the other extreme, when $u = \infty$, then, according to (2) the radius of the circle is zero and its centre is the point (1,0).

The circle given by

$$u = \infty$$

is the point C in Fig. 186(b). Finite values of u give circles of the type shown.

In practice, the quantity u is associated with the loss in amplitude on reflection at an impedance, or with the attenuation of a travelling wave, and it is convenient to attach to each circle its u -value in decibels instead of its immediate u -value in nepers. This has been done in Fig. 185.

If \boxed{X} is put equal to zero in equation (1) we find that the circle cuts the \boxed{R} -axis at distances $\boxed{R_1}$ and $\boxed{R_2}$ from the origin such that,

$$\boxed{R} = \coth 2u \pm \operatorname{cosech} 2u$$

whence, $\boxed{R_1} = \tanh u$ and $\boxed{R_2} = \coth u$

and $\boxed{R_1}\boxed{R_2} = 1$.

This is equivalent to the equation

$$z_s = R_o^2 / z_r \text{ of section 34, where } z_s \text{ and } z_r \text{ are both}$$

resistive.

n-arcs

These are arcs of circles whose equations are,

$$\boxed{R}^2 + (\boxed{X} + \cot 4\pi n)^2 = \operatorname{cosec}^2 4\pi n \dots\dots(3).$$

Their centres therefore lie on the $\pm j\boxed{X}$ axis at the points,

$$(0, -\cot 4\pi n) \dots\dots\dots(4)$$

and their radii are: $\operatorname{cosec} 4\pi n$.

For each value of n within the range 0 to $\frac{1}{2}$ we obtain an arc, but the sequence of arcs repeats if n is increased beyond the value of $\frac{1}{2}$.

An n-arc is shown in Fig. 186(c). According to equation (4) and Fig. 186(c), since in the triangle ODC, $OD = -\cot 4\pi n$ and $DC = \operatorname{cosec} 4\pi n$, the angle $\angle ODC = -4\pi n$ and $OC = 1$.

Thus, all n-arcs start out from the unit point C (1,0).

When $n = 0$ the centre of the arc lies at minus infinity on the $j\boxed{X}$ axis. The arc $n = 0$ is therefore the portion CO of the real axis. As n is increased the centres D move up the $\pm j\boxed{X}$

circles are given in the following (starred) paragraph.

~~xxxx~~

Properties of the Circles and Arcs

u-circles are the loci traced out by the point $\boxed{z_s}$ given by

$$\boxed{z_s} = \frac{\boxed{z_r} + j \tan 2\pi n}{1 + j \boxed{z_r} \tan 2\pi n}$$

where $n = \frac{\ell}{\lambda}$ and

when $\boxed{z_r}$ is kept constant, but n is allowed to vary.

If n is kept constant and $\boxed{z_r}$ is allowed to assume various purely resistive values, the locus of $\boxed{z_s}$ is an n-arc.

u-circles

It may be shown that the equation of a u-circle in the \boxed{R} , \boxed{X} system of coordinates is

$$(\boxed{R} - \coth 2u)^2 + \boxed{X}^2 = \operatorname{cosech}^2 2u \dots\dots\dots(1).$$

The centre of this circle lies on the \boxed{R} axis at the point

$$(\coth 2u, 0) \dots\dots\dots(2),$$

and its radius is,

$$a = \operatorname{cosech} 2u .$$

A u-circle is shown in Fig. 186(b).

By assigning to u a sequence of values a family of circles is obtained in which one circle corresponds to one value of u .

When $u = 0$, equation (2) gives the circle an infinite radius and places its centre at plus infinity along the \boxed{R} -axis.

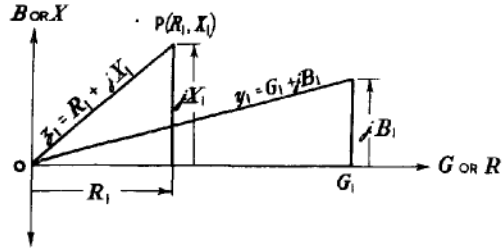

(a)

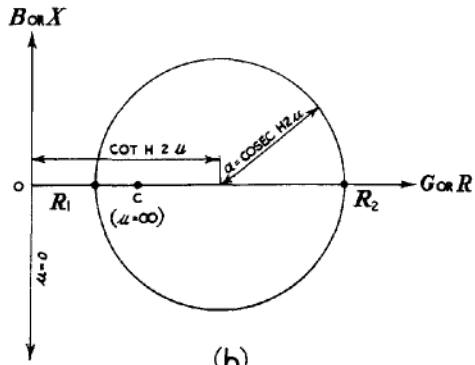

(b)

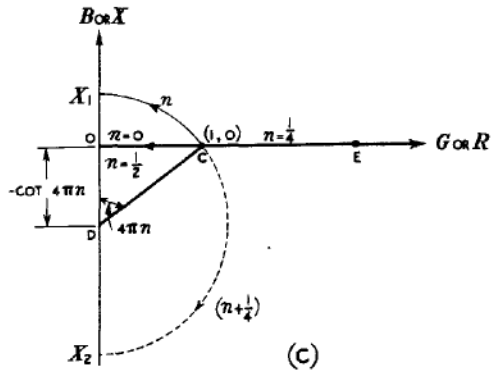

(c)

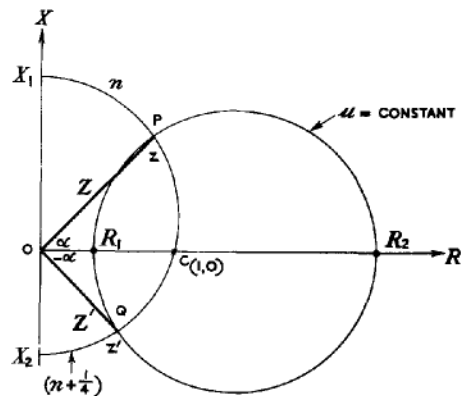

(d)

Fig. 186 - Properties of circle diagram.

axis and finally reach the origin when $n = 1/8$. As n increases further the centre D continues to move upwards and disappears to plus infinity at $n = 1/4$.

The portion CG of the real axis is the arc $n = 1/4$. When n increases in a series of equal increments a set of arcs is obtained in the upper half of the diagram as shown. Those in the lower half are easily obtained by completing the semicircle of which each n -arc in the upper half is a portion. The completing arc, dotted in Fig. 186(c), is called the complementary arc. If the n -value of an upper arc is n , then that of its complementary arc is $(n + 1/4)$. Thus, the n -values of the upper arcs range from $n = 0$ to $n = 1/4$, and of the lower arcs from $n = 1/4$ to $n = 1/2$. The arc $n = 1/2$ is again the line GO which is also the arc $n = 0$.

If n exceeds the value of $1/2$ and is for instance equal to $n = (\frac{h}{2} + n')$ where $h = 1, 2, 3$, etc. then the arc n is the same as the arc n' .

The distances from the origin X_1 and X_2 at which the same semicircle (arcs n and $n + 1/4$), cuts the $\pm jX$ axis are obtained by putting $R = 0$ in equation (3).

$$\text{Thus, } X = \pm \operatorname{cosec} 4\pi n - \cot 4\pi n = \pm \frac{1 - \cos 4\pi n}{\sin 4\pi n}$$

That is,

$$X_1 = \tan 2\pi n; \quad X_2 = -\cot 2\pi n \dots\dots\dots(5)$$

as shown in Fig. 81(c).

It follows that,

$$X_1 X_2 = -1 \dots\dots\dots(6).$$

If X_1 is a normalised reactance then X_2 is the corresponding normalised susceptance and conversely.

50. Applications of the Circle Diagram

Each u -circle corresponds to a particular standing wave distribution on the line. All points corresponding to input impedances at various positions on the same standing wave system lie on the same u -circle. The application of circle diagrams to lossy lines, in which the standing wave ratio varies from point to point, is discussed in Sec. 53.

Each n -arc corresponds to the position of points relative to the standing wave system in which they are located. The difference between two values of n corresponds to the distance along the line, measured in wavelengths; i.e.

$$n_1 - n_2 = \frac{l}{\lambda}$$

An important property of the diagram is illustrated in Fig. 186(d). It shows a complete u -circle enclosing the unit point $C(1, 0)$ and two n -arcs, CP and CQ that intersect it at P and Q . The n -value of each n -arc is marked on it near its end and each u -circle

also is marked with its u -value (Fig. 185). As an inspection of the chart will reveal the values of n run from zero for the arc CO to $n = 1/2$ as CO is reached again from below, whereas the values of u range from zero for the reactive axis of co-ordinates to infinity at the limiting point C. In Fig. 186(d) the arcs CP and CQ belong to the same semicircle and are called complementary. It will be found that if the n -value of any arc CP is n , then that of its complementary arc CQ is $(n + \frac{1}{4})$.

Further, if OP represents the normalised impedance $z = \boxed{R} + j\boxed{X}$ (i.e. P is the point \boxed{R} , \boxed{X}) then OQ represents the normalised impedance (or normalised admittance) $z' = 1/z$. By this we mean that if the length of OP is \boxed{Z} , the magnitude of \boxed{z} , and the angle \widehat{COP} is α , then the length of OQ is $\boxed{Z'} = \frac{1}{\boxed{Z}}$

and the angle COQ is $\alpha' = -\alpha$. It must be stressed that for this to be true CP and CQ must be complementary arcs.

Thus, if $\boxed{z} = \boxed{R} + j\boxed{X}$ is a normalised impedance represented by \overrightarrow{OP} , then the associated normalised admittance $\boxed{y} = \frac{1}{\boxed{z}} = \boxed{G} + j\boxed{B}$ is represented by \overrightarrow{OQ} . (Fig. 186(d)).

In particular, if the angle α is zero then P lies on the real axis and \overrightarrow{OP} represents a pure normalised resistance, $\boxed{R_2}$ say. The point Q will also fall on the real axis at the opposite end of the diameter and will correspond to the conductance $\boxed{G_1} = \boxed{R_1}$, such that $\boxed{R_1}\boxed{R_2} = 1$.

Similarly, when $\alpha = 90^\circ$ the arc CP meets the imaginary axis in the reactance point $+j\boxed{X_1}$. Then the arc CQ meets this axis at the corresponding susceptance point $-j\boxed{X_2}$ such that $\boxed{X_1}\boxed{X_2} = -1$.

51. Numerical Examples

To find the Input Impedance z given R_o , z_r , l and λ . The line is assumed to be loss-free. Refer to Fig. 187(a).

Procedure

1. First normalise z_r , the terminating impedance; thus

$$z_r = \frac{z_r}{R_o} = \frac{R_r}{R_o} + j\frac{X_r}{R_o} = \boxed{R_r} + j\boxed{X_r}.$$

2. Plot the point $\boxed{z_r} = \boxed{R_r} + j\boxed{X_r}$ on the cartesian diagram (Point P, Fig. 187(a)).

3. Note the value of
 - (i) the n -arc n_r ,
 - (ii) the u -circle u_r ,

that pass through P (or estimate these values by interpolation between circles and arcs).

4. Evaluate l/λ and add it to n_r to obtain

$$n_s = n_r + l/\lambda.$$

Since the line is loss-free, $u_s = u_r$.

5. Traverse in a clockwise sense the u-circle $u = u_r$ until it meets the n-arc $n = n_s = n_r + l/\lambda$, at the point Q. At this point the normalised impedance is :-

$$\boxed{z_s} = \boxed{R_s} + j \boxed{X_s}.$$

The input impedance is, as required

$$z_s = R_o \boxed{R_s} + j R_o \boxed{X_s} = R_s + j X_s.$$

Example 1

A loss-free transmission line whose characteristic impedance is 300 ohms and whose length is 0.3λ is terminated by a load, $z_r = (600 + j 300)$.

Find the input impedance.

The normalised load is

$$\boxed{z_r} = \frac{z_r}{R_o} = (2 + j1).$$

From Fig. 185 the u and n-values of the impedance point $\boxed{z_r} = 2 + j1$, are :-

$$u_r = 3.5 \text{ db}; \quad n_r = 0.213.$$

Evaluate

$$u_s = u_r; \quad n_s = 0.213 + l/\lambda = 0.513.$$

The arc $n = 0.513$ is the same as the arc $n_s = 0.013$.

The point of intersection of the circle $u = u_r = 3.5 \text{ db}$ and the arc $n = n_s = 0.013$ is

$$\boxed{z_s} = (0.38 + j 0.07).$$

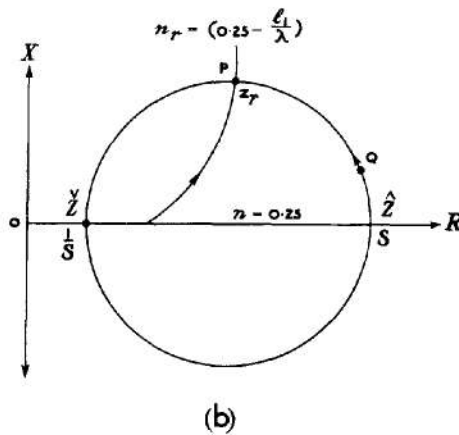
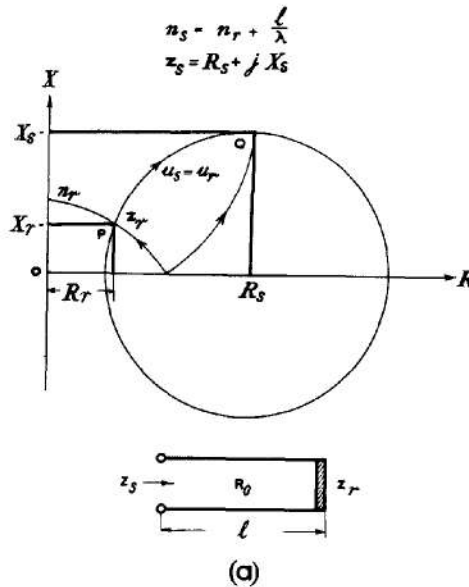

Fig. 187 - Use of circle diagrams.

The input impedance is therefore

$$z_s = 300 \boxed{z_s} = (114 + j 21).$$

Example 2

The transmission line of example 1 is terminated by an admittance $y_R = G_R + j B_R = (0.01 + j 0.005)$.

Find the input admittance.

We treat admittances exactly as if they were impedances. We therefore follow the procedure formulated above:-

The normalised admittance is,

$$\boxed{y_R} = \frac{Y_R}{G_0} = R_0 y_R = 300 y_R = (3 + j 1.5).$$

Plot the point $\boxed{y_R} = (3 + j 1.5)$ and note u_R and n_R . From Fig. 185 we read,

$$u_R = 2.32 \text{ db}; \quad n_R = 0.227.$$

$$\text{Form } n_s = n_R + \frac{l}{\lambda} = 0.227 + 0.3 = 0.527.$$

We may therefore take n_s to be 0.027.

The point of intersection of the arc $n_s = 0.027$ and the circle $u_R = 2.32$ is,

$$\boxed{y_s} = 0.28 + j 0.17.$$

The input admittance is,

$$\begin{aligned} Y_s &= G_0 \boxed{y_s} = \frac{Y_s}{R_0} = \frac{0.28 + j 0.17}{300} \\ &= 0.0009 + j 0.00057. \end{aligned}$$

Example 3

Find the normalised admittance that corresponds to the impedance $\boxed{z_R}$ of example 1.

According to Sec. 50, and Fig. 186(d) the admittance of the impedance $\boxed{z_R}$ which lies at the intersection of the circle u and arc n (vector OP Fig. 186(d)) is represented by the point of intersection of the circle u and the complementary arc $(n + \frac{1}{4})$.

From example 1,

$$\boxed{z_R} = 2 + j 1; \quad u_R = 3.5 \text{ db}; \quad n_R = 0.213.$$

Consequently, for $\boxed{y_R} = \frac{1}{\boxed{z_R}}$

$$u = u_R = 3.5 \text{ db}; \quad n = (n_R + \frac{1}{4}) = 0.463.$$

From Fig. 185

$$\boxed{y_r} = (0.4 - j 0.2).$$

(By calculation: $\boxed{y_r} = \frac{1}{\boxed{z_r}} = \frac{1}{2 + j1} = \frac{2 - j1}{5} = 0.4 - j 0.2$)

Example 4

The transmission line of example 1 is terminated by an inductive reactance $X_r = 150$ ohms. Find z_s when $l = 0.3\lambda$.

We have:-

$$\boxed{X_r} = \frac{X_r}{R_0} = \frac{150}{300} = 0.5; \quad \boxed{z_r} = 0 + j. 0.5 .$$

From Fig. 185

$$u_r = 0; \quad n_r = 0.074.$$

For $\boxed{z_s}$; $u_s = u_r = 0$; $n_s = n_r + l/\lambda = 0.074 + 0.3 = 0.374.$

From the chart $\boxed{z_s} = -j1$. Hence z_s is a capacitive reactance of 300 ohms.

Example 5

Find the standing wave ratio S on the transmission line of example 1.

According to Sec. 13, $S = \frac{\hat{Z}}{R_0} = \boxed{\hat{Z}}$.

The point $\boxed{z_r} = 2 + j1$ lies on the u-circle $u_r = 3.5$ db and arc $n_r = 0.213$.

The impedance z_s becomes purely resistive at the points $\boxed{\hat{Z}}$ and $\boxed{\check{Z}}$ where this circle cuts the resistive axis.

From Fig. 185, this occurs at

$$\boxed{\hat{Z}} = 2.62; \quad \boxed{\check{Z}} = \frac{1}{2.62} = 0.382.$$

Whence $S = 2.62$.

The distance l_1 of $\boxed{\hat{Z}}$, which is that of the nearest voltage antinode from $\boxed{z_r}$ is given by:

$$\Delta n = 0.25 - 0.213 = 0.037 = l_1/\lambda .$$

Whence $l_1 = 0.037\lambda$.

Similarly the distance of the nearest voltage node is at

$$l_2 = (0.5 - 0.213)\lambda = 0.287\lambda .$$

52. Use of Circle Diagram to Determine the Magnitude of the Load Impedance from a Knowledge of the Standing Wave Pattern

A knowledge of the standing wave pattern enables us to determine S and λ , and shows the distances of the voltage nodes and antinodes from the termination. At voltage antinodes and nodes the line impedance becomes purely resistive and attains its maximum and minimum values \hat{Z} and \check{Z} .

Further (see Sec. 13)

$$S = \frac{\hat{Z}}{R_0} = \frac{R}{Z}, \text{ so that}$$

$$\hat{Z} \check{Z} = R_0^2.$$

We may write

$$S = \frac{\hat{Z}}{\check{Z}} = \frac{1}{\frac{\check{Z}}{\hat{Z}}}.$$

Since S determines \hat{Z} and \check{Z} , the representative u -circle is determined uniquely by the standing wave ratio, $(S, 0)$ and $(\frac{1}{S}, 0)$ being the ends of its resistive-axis diameter.

As the distance l from the load is increased the representative point Q of the impedance z_a (Fig. 187(a)) traverses its u -circle.

A displacement of $\lambda/2$ along the line from any position takes Q exactly once round the u -circle so that it returns to the original impedance z_a . Thus the magnitude of the normalised impedance oscillates between the extremes of \hat{Z} and \check{Z} as Q continues to traverse the circumference.

When S , λ and l_1 (the distance of the first voltage antinode from the termination) are known from the standing wave pattern then the procedure of example 5, Sec. 51, may be reversed to give z_r .

Thus we plot $\hat{Z} = S$ on the real axis (arc $n = 1/4$) as shown in Fig. 187(b).

As we move away from the generator towards the load the moving point Q traverses the u -circle in a counter-clockwise sense.

If, therefore, Q starts at S , the position of voltage antinode, it reaches the point P corresponding to z_r where the u -circle through S cuts the arc $n = n_r = (0.25 - l_1/\lambda)$, since z_r lies at a distance l_1 from the voltage antinode on the side away from the generator. The normalised line impedances at all other positions in this standing wave pattern are represented by points on the u -circle through S .

Example

Suppose $S = 5$ and $l_1 = 0.1\lambda$. Find z_r .

Then $u = 1.8$. The intersection of the circle $u = 1.8$ with

the arc $n = 0.25 - 0.1 = 0.15$ is the point $\boxed{z_r} = 0.55 + j 1.23$.

53. Application of Circle Diagrams to Lines with Low Losses

When the line loss cannot be neglected then it is not only necessary to evaluate $n_s = n_r + \ell/\lambda$ but also to determine the value of u_s which is no longer equal to u_r ; that is, the representative point does not remain on the same u -circle for different lengths of the line. If the movement on the line is away from the load towards the generator then u_s increases with ℓ and Q moves on the diagram in a spiral towards the limiting point C (1,0). When ℓ becomes large then the input impedance z_s is always represented by a point very near C. This is equivalent to saying that the normalised input impedance of a long attenuating transmission line is

$$\boxed{z_s} \doteq 1; \text{ i.e., } z_s \doteq R_0.$$

The conversion of u to u_s is made as follows. It is supposed that the signal loss in decibels in a standard length of the line (say 100 feet) is known. Suppose that the transmission line shown in Fig. 187(a) produces an attenuation in a travelling wave of a_f decibels per unit length and therefore $a = a_f \ell$ decibels for length ℓ . To find the normalised input impedance $\boxed{z_s}$ when $\boxed{z_r}$ is known

proceed as follows:-

Locate $\boxed{z_r}$ as before on the diagram and note u_r and n_r .

(u_r in decibels).

Evaluate $u_s = (u_r + a)$ and $n_s = (n_r + \ell/\lambda)$.

Move clockwise around the u_r circle up to the arc n_s . Move inwards along the n_s arc to its point of intersection with the circle u_s .

This determines the representative point of $\boxed{z_s}$

Example

A resistance of 200 ohms terminates a 50 ft length of Uni-radio 1 cable ($R_0 = 72$ ohms; $a_f = 3.5$ db. per 100 feet at 200 Mc/s. and $K \doteq 2.25$): Find the input impedance at a frequency of 200 Mc/s.

$$a = a_f \ell = 3.5 \times \frac{50}{100} = 1.75 \text{ db.}$$

The wavelength in air is $1\frac{1}{2}$ metres and in the cable is

$$\frac{3}{2} \cdot \frac{1}{\sqrt{K}} = 1 \text{ metre. Whence } \ell/\lambda \doteq 15.25.$$

$$\boxed{z_r} = \frac{200}{72} = 2.78 + j.0$$

From Fig. 185

$$u_r = 3.3; \quad n_r = 0.25$$

$$u_s = 3.3 + 1.75 = 5.05 \text{ db; } n_s = n_r + 15.25 = 15.5$$

The arc $n = n_s$ is equivalent to the arc $n = 0$

From Fig. 183

$$\boxed{z_s} = 0.53 + j.0 .$$

Hence $z_s = 72 \boxed{z_s} = (37.4 + j.0).$

54. Application of Circle Diagrams to Matching Devices constructed from Sections of Uniform Loss-free Transmission Line

(i) Important Property of Circle Diagrams

Refer to Fig. 188; let \overline{OR} represent the impedance $\boxed{z_r}$, and \overline{OP} the corresponding input impedance at the point P distance l_r from R. If $\boxed{z_r}$ varies in such a manner that the point R traces out a

circle, then it can be shown mathematically or by plotting a series of points that the point P also traces a circle, (or, in some cases, a straight line).

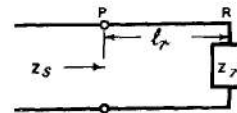

(a)

The method of plotting the point P corresponding to a particular position of R is indicated in the figure. In the particular case when the circle-locus of R degenerates into a straight line (circle of infinite radius) the locus of P is still in general, a circle.

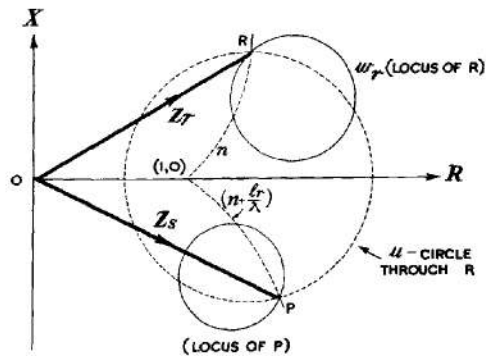

(b)

The property is of importance in the demonstration of some matching problems using circle diagrams. It is used in the cases given below, of Double Stub Matching and Matching by Slugs.

*** Mathematically, the relation

Fig. 188 - Important property of circle diagrams.

$$\boxed{z_s} = \frac{1 + j \boxed{z_r} \tan \frac{2\pi l}{\lambda}}{\boxed{z_r} + j \tan \frac{2\pi l}{\lambda}}, \text{ where } l \text{ is constant,}$$

is of the form

$$\boxed{z_s} = \frac{\alpha + \beta \boxed{z_r}}{\gamma + \delta \boxed{z_r}}, \text{ where, in general, } \alpha, \beta, \gamma, \delta \text{ are complex as well as } \boxed{z_s} \text{ and } \boxed{z_r}.$$

This may be written in the form

$$\boxed{z_s} = \alpha' + \frac{\beta'}{\boxed{z_r} + \gamma'}, \text{ and is equivalent to the following steps:-}$$

- (1) a translation,
- (2) an inversion,
- (3) a magnification and a rotation, and
- (4) a further translation.

None of these steps distorts the circular shape of the locus of $\boxed{z_r}$.

[Step (2) may transform a circle into a straight line - i.e., a circle of infinite radius - or vice versa.]

(ii) $\lambda/2$ Transformer

The action of this, the simplest of line transformers, is demonstrated by the movement of the point P (Fig. 186(d)) once completely round the appropriate u-circle.

(iii) $\lambda/4$ Transformer

In this case the point P, corresponding to $\boxed{z_r}$ (Fig. 186(d)) traverses the appropriate u-circle from the n-arc to the $(n + \frac{1}{2})$ -arc, i.e. to the point Q.

(iv) Double $\lambda/4$ Transformers

Consider first the behaviour of a single $\frac{\lambda}{4}$ transformer when a small increase in frequency causes the line to become rather more than

$\frac{\lambda}{4}$ in length. This is illust-

trated in Fig. 189(a), for the case in which input and output impedances are required to be resistive. If the terminating impedance is R_r , (assume $R_o > R_r$), normalised impedance is given

by $\frac{1}{S} = \frac{R_r}{R_o}$, where S is the standing wave ratio, and is represented by R. The input impedance $\frac{R_o^2}{R}$ when normalised is $\frac{R_o}{R}$ and

is represented by P(S, 0) provided the length of the transformer is exactly $\frac{\lambda}{4}$. If this

is increased a reactive term is introduced, illustrated by the point P'. Although the resistive component of the input impedance is still approximately correct a considerable phase error may be introduced for a small change in wavelength.

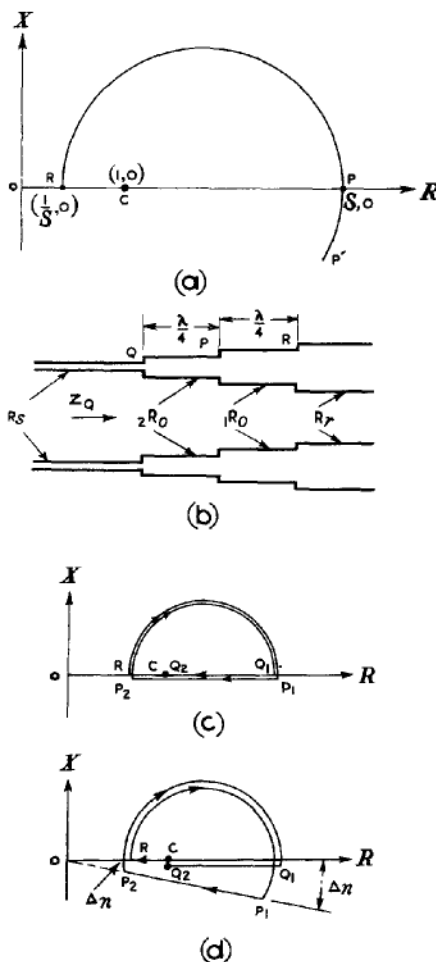

Fig. 189 - Double $\lambda/4$ transformer.

Fig. 189(b) shows a double $\frac{\lambda}{4}$ transformer used

to minimise the above effect. The characteristic impedances, $1R_0$ and $2R_0$ of the $\frac{\lambda}{4}$ sections of line are related to the resistances at the receiving and sending ends of the line, in this case the characteristic resistances of the respective feeders, by the relations

$$1R_0 = a R_r \quad \text{and} \quad 2R_0 = a^2 \cdot 1R_0, \quad \text{where} \quad \frac{R_s}{R_r} = a^4.$$

The change of characteristic impedance at the junction generally necessitates changing from one u-circle to another, since for each separate section of line the impedance considered must be normalised with respect to the appropriate characteristic resistance.

This is illustrated at (c) for the case when each section of the double-transformer is exactly $\frac{\lambda}{4}$ in length. Since $\frac{R_r}{1R_0} = \frac{1}{a}$,

the standing wave ratio for the first $\frac{\lambda}{4}$ section is a , and the point R of the circle diagram, corresponding to the input impedance at R (Fig. 189(b)), normalised with respect to $1R_0$, is the point $(\frac{1}{a}, 0)$. The point C (1,0) represents the terminating impedance R_r normalised with respect to itself. Hence we may consider the change in characteristic impedance at R to be represented on the diagram by movement of the representative point from C to R. The change due to the movement from R to P (Fig. 189(h)) is represented by movement from R to P_1 along the u-circle. Since R is the point $(\frac{1}{a}, 0)$, P_1 is the point $(a, 0)$. The change in characteristic impedance from $1R_0$ to $2R_0$ at P necessitates dividing the normalised impedances by a^2 , since $2R_0 = a^2 1R_0$, so that $\frac{z}{2R_0} = \frac{1}{a^2} \cdot \frac{z}{1R_0}$. This transfers the representative point to P_2 , which is $(\frac{1}{a}, 0)$, the same as R. Movement from P to Q (Fig. 189(b)) is represented by movement along the u-circle from P_2 to Q_1 in Fig. 189(c). Finally, since $R_s = a \cdot 1R_0$, the change in impedance levels at Q is represented by dividing the new impedance by a ; i.e., the representative point returns to $Q_2 \equiv C$ and the line is properly matched.

If the frequency is slightly increased so that the electrical length $\frac{l}{\lambda}$ of each of the matching sections is increased by the same

amount, the conditions are altered to those shown in Fig. 189(d). Provided the frequency shift is not too large the change in n-value at P_2 is the same as at P_1 (this can be verified from Fig. 185) so that to a first approximation Q_1 is not shifted, and the input impedance represented by Q_2 satisfies the requirements for a broad-band match.

A similar argument shows that any odd number of transformers with appropriate characteristic impedances, used in cascade, is sensitive to changes in frequency, whereas any even number is not. However, the more $\frac{\lambda}{4}$ sections there are inserted between R_r and R_s the

smaller is the standing wave ratio on each section and the more closely do the appropriate u-circles approach the point C. If a large number of such transformers is used, with their characteristic impedances exponentially graded, a wide-band match is achieved irrespective of whether the number of sections is odd or even.

(v) Single Shunt Stub

This matching device is illustrated in Fig. 190(a). The position of the stub, distant l_1 from the termination $T_1 T_2$ is variable, and also the length l_2 of the stub. It is required to adjust l_1 and l_2 so that the input admittance at $P_1 P_2$ has a required value y_s (usually the characteristic admittance of the line connected to $P_1 P_2$).

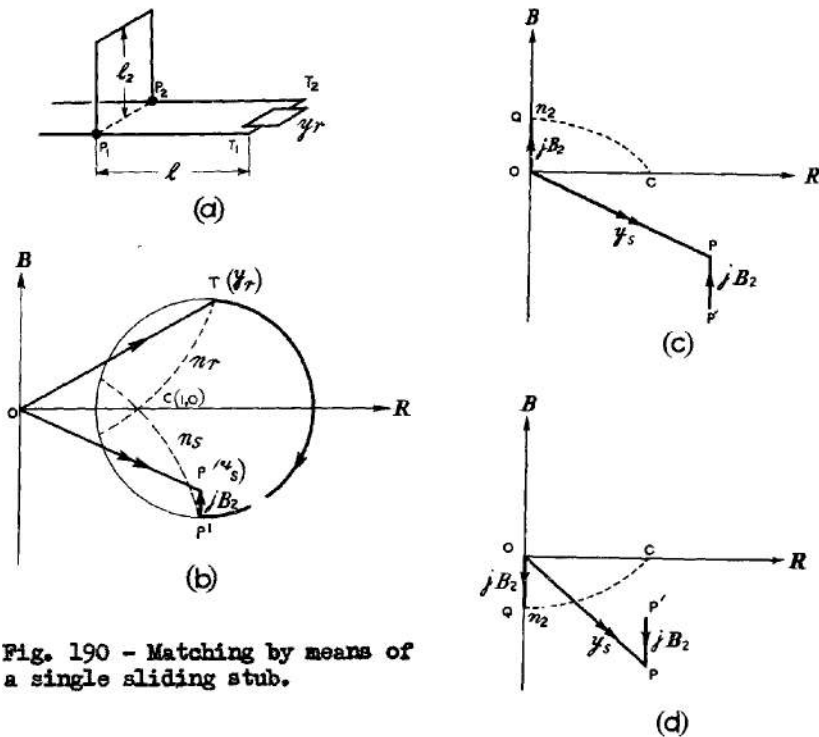

Fig. 190 - Matching by means of a single sliding stub.

The terminating admittance y_r and the characteristic impedance R_0 determine the standing wave pattern and the appropriate u -circle $u = u_r$ for the section PT (Fig. 190(b)). On this circle the points T and P (representing the required input admittance) are known. The stub-length l_2 is adjusted until a susceptance jB_2 is shunted across the line at $P_1 P_2$. This procedure determines the point P' . (There are two alternative positions for P' corresponding to two complementary solutions to the problem. They are the intersections with the circle $u = u_r$ of a vertical line drawn through C . Only one of these two positions is shown on the diagram). P' determines the value n_s of the required n -arc. The distance l_1 between stub and termination is given by $\frac{l_1}{\lambda} = n_s - n_r$.

If y_s may have any value a match is not always possible, i.e. the line through y_s parallel to the susceptance axis may not intersect the circle $u = u_r$. In most cases however y_s is the

characteristic admittance of a line identical with that forming the section PT so that $\overline{y_s} = 1$. In this case $\overline{y_s}$ is the point C (1,0) and two solutions are always possible, one of which corresponds to a length ℓ_1 less than, and the other greater than $\lambda/4$. The shorter length is usually preferable. The length ℓ_2 corresponding to the susceptance $\overline{B_2}$ may be obtained from the circle diagram as indicated below or from the formulae;

$$\overline{B_2} = - \cot \frac{2 \pi \ell_2}{\lambda} \text{ for a short-circuited stub.}$$

$$\overline{B_2} = + \tan \frac{2 \pi \ell_2}{\lambda} \text{ for an open-circuited stub.}$$

The determination from the circle diagram of the length ℓ_2 corresponding to the susceptance $\overline{B_2}$ is illustrated at (c). For an open-circuited stub draw OQ so that OQ = $\overline{B_2}$. The value n_2 of the n-arc through Q then gives ℓ_2 from the relation

$$n_2 = \frac{\ell_2}{\lambda}$$

It is important that the direction of the admittance $j\overline{B_2}$ is determined correctly. In the case illustrated at (d) the point Q lies below the origin, corresponding to a value of n_2 between 0.25 and 0.5.

If a short-circuited stub is used 0.25λ must be added to, or subtracted from, the length ℓ_2 obtained above for the open-circuited stub.

Numerical example

The results of an actual experiment are quoted in illustration.

The unscreened twin transmission line of Fig. 191 comprised a pair of copper wires in tension. The characteristic impedance was $R_0 = 320$ ohms.

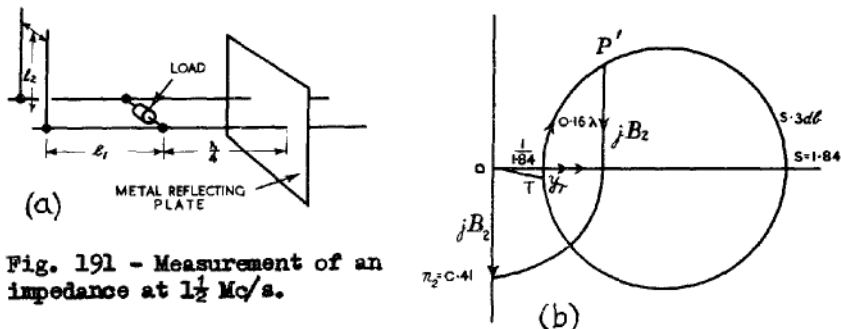

Fig. 191 - Measurement of an impedance at $1\frac{1}{2}$ Mc/s.

The lines with the stub omitted were fed from a low power, loosely coupled 200 Mc/s. oscillator and a complete standing wave was produced on the line by using the metal plate termination shown. The wavelength was obtained from the standing wave pattern using a standing wave indicator.

The measured wavelength was 151 centimetres.

It was found that a voltage antinode existed exactly at $\lambda/4$ from the plate which behaved therefore as a termination of zero impedance.

A resistor whose nominal value was 560 ohms was shunted across the line at $\lambda/4$ from the plate, i.e. where the line impedance was infinite. The terminating impedance of the line to the left was therefore that of the resistor alone. A standing wave ratio $S = 1.84$ was found on the line and a voltage node was located at $l_n = 39$ centimetres from the resistor towards the generator. At this point the normalised admittance of the line is $S + j.0 = 1.84 + j.0$ (See Sec. 52). This point lies on the circle $u = 5.3$ db. and the arc $n = 0.25$. We have $l_n/\lambda = \frac{39}{151} = 0.258$. Consequently,

the admittance point $\boxed{y_r}$ of the termination is the point of intersection of the circle $u = 5.3$ db. and the arc $u = (0.25 - 0.258) = -0.008$ which is equivalent to the arc $n = 0.492$. This gives $\boxed{y_r} = 0.54 - 0.04j$

$$\text{or } \boxed{z_r} = \frac{0.54 + 0.04j}{(0.54)^2 + (0.04)^2} = 1.8 + j. 0.136 .$$

$$z_r = 320 \boxed{z_r} = (576 + j. 4.36),$$

i.e. the "560 ohm resistor" has in fact a resistance of 576 ohms in series with an inductive reactance of 4.36 ohms.

The standing wave on the line was eliminated by the use of a short-circuited shunt stub as in Fig. 191(a). The point y_r occupies a position on the circle $u = 5.3$ db. as shown in Fig. 191 (b). The length of line from y_r to P' is given by

$$\Delta_n = 0.15 - 0.49 = -0.34 \text{ which is equivalent to}$$

$$\Delta_n = 0.16$$

Hence the stub must be placed 0.16λ from the load, i.e. $l_1 = 24.2$ cms.

Since a short-circuited stub is used its length l_2 is given by $l_2/\lambda = 0.25 + n_2$. From the circle diagram we obtain $n_2 = 0.41$, so that $l_2/\lambda = 0.66$ which is equivalent to $l_2/\lambda = 0.16$. Hence l_2 also is 24.2 cms.

(vi) Double Shunt Stub

Fig. 192(a) illustrates the use of two shunt stubs of variable lengths l_1 and l_3 separated by a fixed distance l_2 for matching a line

to a terminating admittance y_r . It will be assumed, as is common in practice, that all portions of the line and stub have the same characteristic admittance G_0 . It is thus required to adjust the lengths l_1 and l_2 so that the terminating admittance y_r is correctly matched to G_0 .

As l_1 is varied the normalised admittance given by:-

$$\begin{aligned} \boxed{y_2} &= \boxed{y_r} + j\boxed{B_1} \\ &= \boxed{G_r} + j(\boxed{B_r} + \boxed{B_1}) \end{aligned}$$

traces a line parallel to the susceptance axis through $(\boxed{G_r}, 0)$, Fig. 192(b). Since l_2 is constant the corresponding admittance (y_3) traces out a circle (see (i) above).

This $\boxed{y_3}$ - circle touches the circle $u = 0$ (the susceptance axis) corresponding to the short-circuiting of the line when $l_1 = 0$, ($n = 0.25$), the point of contact being given by $u = 0$, $n = n_2 + 0.25 = \frac{l_2}{\lambda} + 0.25$.

It also touches the circle $u = u_1$ when $B_r + B_1 = 0$

(i.e. $\boxed{y_2} = \boxed{G_r} + j.0$),

the point of contact being given by $u = u_1$, $n = n_2$

when $\boxed{G_r} < 1$ and $n = n_2 + 0.25$ when $\boxed{G_r} > 1$.

Actually the $\boxed{y_3}$ - circle can be shown to have centre

$$\frac{1}{2\boxed{G_r}} \operatorname{cosec}^2(2\pi n_2) - j \cot(2\pi n_2)$$

and radius

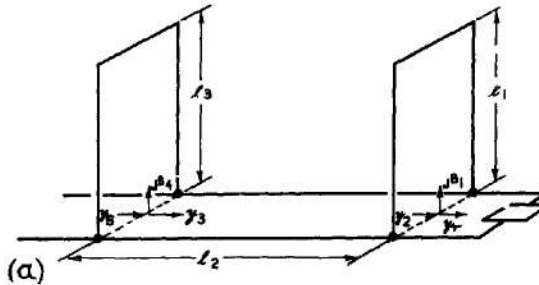

LIMITS WITHIN WHICH y_s MUST LIE FOR A MATCH TO BE POSSIBLE

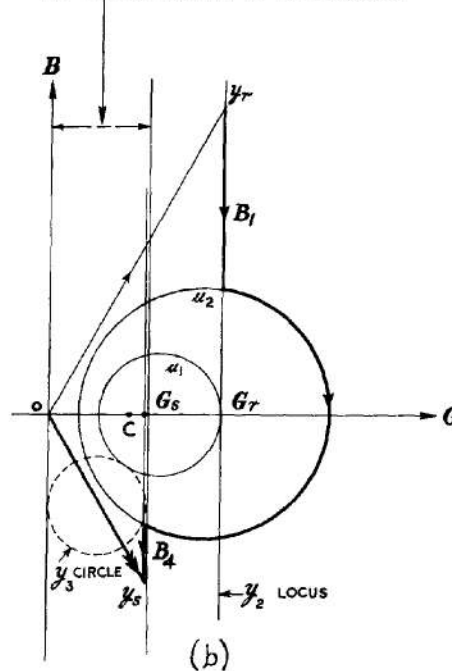

Fig. 192 - Matching by double shunt stub.

$$\frac{1}{2[G_r]} \operatorname{cosec}^2 (2\pi n_2).$$

As $y_s = y_3 + j B_4 = G_s + j (B_3 + B_4)$ the possible range of y_s available for a given y_r is given by the vertical belt shown enclosing the y_3 -circle.

For the required value of y_s ,

$$y_3 = y_s - j B_4 = G_s + j (B_s - B_4)$$

and the locus of satisfactory values for y_3 is another line parallel to the susceptance axis, this time through G_s . From an intersection, following in a counter-clockwise direction the circle $u = u_2$, which passes through the chosen point, for a distance corresponding to $n_2 = \frac{\ell_2}{\lambda}$, the appropriate value of y_2 is reached. Only one of the two possible solutions is illustrated in Fig. 192(b).

The stub lengths ℓ_1 and ℓ_3 may be determined from the normalised susceptances B_1 and B_4 by the method indicated in (v) above.

(vii) Matching by slugs

In general two degrees of freedom are needed in a device for matching a line to a given load, so that a single slug is not adequate. A slug may be combined with another matching device, such as a shunt stub. The following demonstration will be restricted to the particular case in which two identical movable $\lambda/4$ slugs are employed.

Suppose that two $\lambda/4$ slugs are inserted in a line of characteristic impedance R_0 so that the line with the slug present has a characteristic impedance $\frac{R_0}{m}$ ($m > 1$), as shown in Fig. 193(a).

Suppose that the standing wave ratio on the length ℓ_1 is S and that it is required to adjust ℓ_1 and ℓ_2 , if possible, so that the line at A is properly matched.

The circle diagram (b) illustrates the procedure. The circle $u = u_D$ represents the input impedance of the line to the right of D. This circle has as the extremities of a diameter the points $(\frac{1}{S}, 0)$ and $(S, 0)$. For brevity we shall denote this and

similar circles as the circle $(\frac{1}{S}, S)$. The impedance z_D corresponds to a point on the circle $u = u_D$, the position of this point depending on the exact position of z_r and the value of $n_1 = \frac{\ell_1}{\lambda}$. It is necessary to convert the locus $u = u_D$ to the locus of the impedance $\frac{z_D}{m}$, which is the impedance of z_D

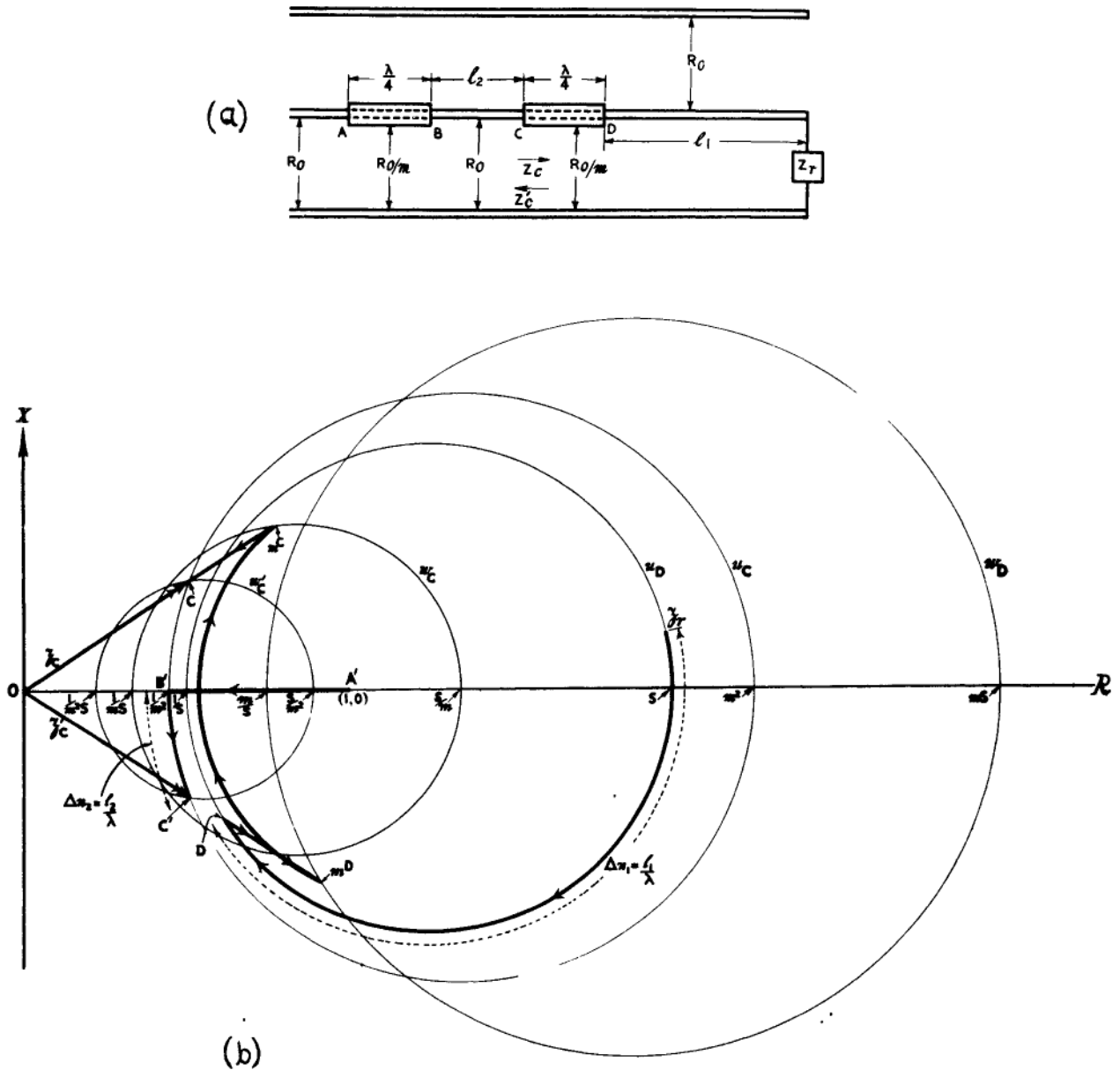

Fig. 193 - Matching by double $\lambda/4$ sliding slugs.

normalised with respect to $\frac{R_0}{m}$. This is done by multiplying each value of $\boxed{z_D}$ by m ; the circle labelled ω_D is thereby obtained (not a u-circle). The ends of its \boxed{R} -axis diameter are $(\frac{m}{S}, mS)$.

As $\boxed{mz_D}$ traverses the circle ω_D the input impedance $\boxed{mz_0} = \frac{1}{\boxed{mz_D}}$ (normalised with respect to $\frac{R_0}{m}$) at C, $\frac{\lambda}{4}$ from D, traces another circle ω_c . (See (i) at the beginning of this section). This circle is given by $(\frac{1}{mS}, \frac{S}{m})$. To convert this impedance - variation so that it represents the termination of the portion BC (normalised with respect to R_0) it is necessary to divide each impedance ω_c by m ; the locus of z_c is thereby obtained, this circle ω_c' being given by the points $(\frac{1}{m^2S}, \frac{S}{m^2})$.

Hence as the line length ℓ_1 is varied, with a constant termination $\boxed{z_r}$ the input impedance seen looking to the right at C traces the circle ω_c' .

We now consider the conditions at the sending end. The impedance to the left of A is R_0 , denoted by A' (1, 0). (The primed letters are here used to denote that the impedance is viewed from the right in Fig. 193(a), not from the left as for the unprimed letters). The impedance to the left of B is given by R_B where

$$R_0 R_B = \left(\frac{R_0}{m}\right)^2; \text{ i.e. } R_B = \frac{R_0}{m^2}, \text{ and its normalised}$$

value is $\frac{1}{m^2}$. This gives the point B' . The circle $u = u_0$ which corresponds to the standing wave pattern on the line BC is then the circle $(\frac{1}{m^2}, m^2)$, and the distance ℓ_2 from B to C (Fig. 193(a)) is given by the change in the 'n'-value of the n-arcs from B' to C' traversed in an anticlockwise direction, i.e.,

$$\Delta n_2 = \frac{\ell_2}{\lambda} = n(B') - n(C').$$

The condition for a correct match at C is that the impedances denoted by C and C' should be conjugate. C must therefore lie at the opposite end from C' of a vertical chord of the circle $u = u_0$. Hence it is necessary that the circles $u = u_0$ and $\omega = \omega_c'$ intersect. The point B' always lies inside the ω_c' -circle, since the ends of diameter of this circle are $\frac{1}{m^2 S}, \frac{S}{m^2}$ and B' is the point $\boxed{R} = \frac{1}{m^2}$,

S being greater than 1. Hence for intersection to occur it is necessary that the other end of this diameter, $\boxed{R} = m^2$, should lie outside the ω_c' -circle, i.e.,

$$m^2 > \frac{S}{m^2}, \text{ or } S < m^4.$$

Hence matching is possible by this method provided the standing wave ratio introduced by the mis-match at the termination is not greater than m^4 .

The various impedance transformations which occur in this method of matching are illustrated by the heavy lines in Fig. 193(b). Two solutions are possible, but only one is indicated. For simplicity the transformation due to the $\frac{\lambda}{4}$ transformer AB is shown as a straight line from A' to B' . As described in (iii) above the impedance actually follows a u -circle (after first being normalised with respect to $\frac{R}{m}$). The distance ℓ_2 may be determined directly, as indicated, and the distance ℓ_1 can be similarly determined when the position of the load impedance $\boxed{z_r}$ is located on the circle $u = u_0$.

The problem of slug-matching is more complicated if the slugs are not $\frac{\lambda}{4}$ in length, but the procedure is the same. The loci are still circles, but the mutual relations are more complex and are not considered further.

(viii) Wide-band stub support (metallic insulator)

The arrangement is illustrated in Fig. 194(a). Suppose the characteristic resistances of the lines FQ, QR are each $\frac{R_0}{m}$, where R_0 is the characteristic resistance of the main line and $m > 1$. The circle $u = u_1$ (Fig. 194(b)) indicates the input admittance of the line QP terminated at P in R_0 for various lengths. If this line is $\lambda/4$ in length, Q is the current antinode on this u -circle. If the frequency of operation increases so that the line is slightly more than $\lambda/4$, Q appears as shown, so that the admittance \overrightarrow{OQ} contains a small inductive susceptance. If the input admittance $j\mathcal{B}$ of the stub QT is of the right magnitude, the resultant admittance, $\overrightarrow{OQ} + \overrightarrow{OQ'} = \overrightarrow{OQ'}$ brings the admittance back on to the circle $u = u_1$, and the input admittance of the line RQ at R, terminated as it is at Q, is the same as that at P, namely G_0 , as shown by its normalised value $\frac{1}{m}$.

Thus, provided the change of frequency which introduces the inductive susceptance in the input admittance at Q produces just the right capacitive susceptance in the input admittance of the stub QT, a wide-band match is obtained.

If the characteristic resistance of the stub is $\frac{R_0}{t}$, it may be shown that the condition for a correct match is given by

$$t = 2m(m^2 - 1).$$

A particular case arises when $t = m = \sqrt{\frac{3}{2}}$. In

this case the same thickness of inner cable may be used for both the stub and the thickened line PR.

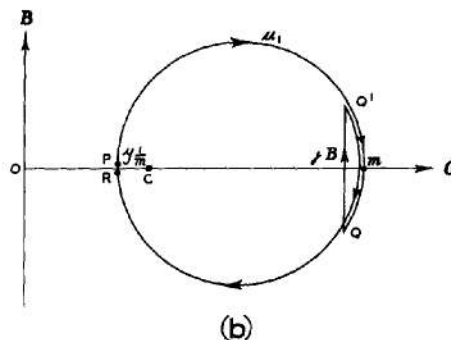
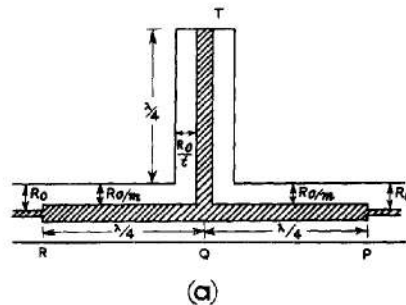

Fig. 194 - Wide-band stub support.

This Page Intentionally Blank

This file was downloaded
from the RTFM Library.

Link: www.scottbouch.com/rtfm

Please see site for usage terms,
and more aircraft documents.

