

Chapter 6
ELECTRONIC DEVICES
List of Contents

	Sect.
Cathode ray tubes	
Construction and operation	1
Types of tube	2
The cathode	3
The anode	4
The control electrode (control grid)	5
Brilliance	6
The fluorescent screen	7
Screens with multiple layers	8
The skiatron or dark-trace tube	9
The glass-envelope	10
Focusing systems	
General	11
Electrostatic focusing	12
Magnetostatic focusing	13
Gas focusing in soft tubes	14
Deflection systems	
General	15
Electric deflection	16
Magnetic deflection	17
Distortions and their correction	
Trapezium distortion	18
Deflection defocusing	19
Astigmatic distortion	20
Bulb charge and deflector plate current	21
Stray fields leading to distortion	22
Comparison of focusing and deflection systems	23
Post-deflector acceleration	24
Double-beam tube	25
Power supplies and shift networks	
General	26
Power supplies	27
Shift voltage for electric deflection systems	28
Shift current for magnetic deflection systems	29
Input circuits	
Input circuits to deflector plates	30
Input circuits to grid and cathode	31
Hard valves	
Introduction	32
Power valves for radar transmitters	33
Suppressor-grid characteristics	34
Soft valves	
Summary on the effect of gas in valves	35
Cold cathode gas diode	36
Hot cathode gas diode	37
Hot cathode gas triode	38
Spark gaps	39
The triggered spark gap	40
The rotary spark gap	41
The T/R switch	42
Special resistors	
General	43
Metrosil	44
Thermistors	45

ELECTRONIC DEVICESCATHODE RAY TUBES1. Construction and Operation

The Cathode Ray Tube (CRT) is the principal display device in most radar systems. It can be thought of as an indicating device with a very light pointer which has no inertia. The pointer is, in fact, a beam of electrons which can be deviated by means of electric or magnetic fields. Where the electron beam impinges upon the fluorescent screen of the tube it forms a spot of light, and as the beam is moved the spot traces out a pattern on the screen which is called the Trace. The brightness of the spot can be altered by the application of suitable potentials so that the trace may be made brighter in some parts than in others. In some tubes the trace on the screen is transitory and disappears as soon as the electron beam is displaced, while in others there is an afterglow period so that the trace remains visible for some time after the electron beam is moved.

It is instructive to compare the internal construction of a CRT with that of a triode. In a triode the control grid is used to vary the quantity of electrons reaching the anode so that the electron stream from the cathode is intensity modulated. In a similar way a cathode ray tube has a cathode to produce a stream of electrons which are accelerated by an anode system and can be intensity modulated by the variation of potential difference between the control electrode and the cathode. The electron stream, however, needs to be concentrated (focused) in a narrow beam so that after it has passed through the anode system it produces a small sharply defined spot of light.

The beam of electrons can be changed in direction by an electric or a magnetic field or can be modulated in intensity, or both, and the effects will be made visible on the fluorescent screen. If the beam of electrons is deflected rapidly and repeatedly the moving spot of light will produce a persistent trace on the screen. Intensity modulation of the beam will vary the number of electrons reaching the screen in a given interval of time and so alter the brightness (brilliance) of the spot or trace (Fig. 264).

The cathode ray tube consists essentially of:-

- (i) The electron gun (or, simply, the gun) comprising:- a cathode which acts as a source of electrons; a control electrode which alters the electron concentration in the beam; and an anode to accelerate the electrons.

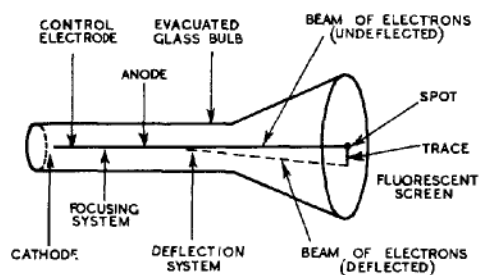

Fig. 264 - Schematic layout of CRT

- (ii) A focusing system which is commonly (in electrostatic focusing) part of the gun.
- (iii) A deflecting system.
- (iv) A fluorescent screen.
- (v) An evacuated glass bulb.

2. Types of Tubes

(i) The most common type of tube used in radar is the hard tube in which the glass envelope containing the electrode system is sealed off after the air pressure has been reduced to about 10^{-6} mm. of mercury. The accelerating potential may have a value from about 500 V to about 5 kV. depending on the size of the tube; tubes normally have screen diameters between 1 and 15 inches.

(ii) Soft tubes, in which the gas pressure is about 0.01 mm. of mercury, are also in use. They usually employ an accelerating potential whose value lies between 200 and 1000 V. This type of tube has serious disadvantages compared with the hard tube (Sec. 14) and is not commonly used.

3. The Cathode

The cathode is usually of the indirectly heated type and consists of a small nickel tube closed at one end. The emissive substance (such as a mixture of barium and strontium oxides) is situated in a depression in the closed end of the tube and the heater, supplied with an alternating voltage (from 4 to 6.3 V. depending on the particular CRT) is inserted through the open end of the tube. The beam current is of the order of 30 - 300 microamps. Directly heated filaments are not commonly used as cathodes except in soft tubes, since if they are supplied with an alternating voltage the electron stream is likely to be adversely affected.

4. The Anode

The anode is mounted a short distance from the cathode on the side nearer the fluorescent screen, and usually (when the anode is also part of the focusing system) takes the form of a disc with a hole about 1 mm. in diameter in the centre. When the anode is simply an accelerating electrode, it often takes the form of a conducting layer of carbon particles (aquadag coating) on the inside surface of the glass envelope of the CRT.

The potential of the anode is maintained at some hundreds or thousands of volts positive with respect to the cathode in order to accelerate the electrons. Some electrons travelling at a high speed from the cathode are collected by the anode, whilst some pass through the hole and continue to travel down the tube until they strike the fluorescent screen. The electron beam is divergent, due partly to the mutual repulsion of the electrons as they pass down the tube, and partly to the angle at which electrons from different parts of the emitting surface pass through the anode aperture. This divergence tends to cause the spot of light on the fluorescent screen to be large and diffuse. To make the spot small and well defined the electrons must be made to converge so as to strike the screen over as small an area as possible. A focusing system (Secs. 11 - 14) is used for this purpose.

5. The Control Electrode (Control Grid)

Only a small proportion of the total number of emitted electrons pass through the hole in the anode unless the electron stream from the cathode can be compressed into a narrow beam which can pass through the anode aperture. This compression is performed by the Control Electrode which usually takes the form of a hollow nickel cylinder surrounding the cathode. It is called the Shield, Wehnelt Cylinder or Grid, the last name being generally used because the electrode has a control on the beam current similar to that exerted by the control grid of a triode valve on the anode current. If a potential, negative compared with that of the cathode, is applied to the grid a region of minimum potential is produced in the neighbourhood of the cathode. The immediate effect of this potential minimum is to reduce the divergence of the electron stream. Increasing values of negative potential on the grid cause the electron stream to become more and more compact until at some optimum value the majority of the electrons pass through the anode aperture. However, if the negative potential is increased beyond this value there is an appreciable reduction in the beam current. In a valve the anode current is reduced in a similar manner. The brightness or brilliance of the spot on the CRT screen depends on the number of electrons reaching the screen in a given interval of time and so is controllable by the potential on the grid. The grid potential can be made sufficiently negative so that the grid field neutralises that of the anode. Then the beam of electrons is cut off and the spot of light on the screen is "blacked out". This corresponds to cut-off bias on the grid of a triode.

6. Brilliance

The intrinsic brilliance of the spot depends on the energy contained in the beam. It is, therefore, proportional to both:-

- (i) The square of the velocity of the electrons, which depends on the potential difference between anode and cathode, and
- (ii) the current density (number of electrons striking the screen per unit interval of time) of the beam which largely depends (Sec. 5) on the potential difference between the grid and cathode.

If the spot is swept over the screen the energy of the illumination is spread over a large area. Hence, on the assumption that the frequency with which the movement of the spot is repeated remains constant, the greater the magnitude or speed of this movement, the less the apparent brilliance of the trace. Thus, high speed and large tubes require high anode voltages in order to produce adequate brilliance. When the spot is stationary the brightness must be reduced to a minimum (by control of the grid-cathode voltage), otherwise the persistent electron bombardment causes a portion of the screen to lose its fluorescence; the tube screen is then said to be "burnt" and no fluorescence appears afterwards at this place.

7. The Fluorescent Screen

The screen consists of a translucent layer of fine powder adhering to the end of the tube. The emission of light during the actual stimulus of the beam is termed fluorescence; light which continues to be emitted after the stimulus has been removed is due to phosphorescence and is called Afterglow. The material of the powder determines the colour of the trace, and also the duration of afterglow.

The desirability or otherwise of using a screen with long afterglow depends on the purpose for which the tube is to be used.

The behaviour of the screen, including its luminous efficiency, depends greatly on the purity of the compound used. Such substances as calcium tungstate (blue-violet trace), zinc silicate (green), zinc phosphate (red) and preparations of zinc sulphide and zinc cadmium sulphide are a few from amongst those that may be used. A minute trace of an Activator such as silver or copper is necessary to produce the maximum luminous efficiency, which is of the order of 1 - 5 candle power per watt. In a good many cases afterglow of a screen is limited to a few microseconds, and by the addition of a suitable "killer" such as a compound of nickel, it can be cut down to a fraction of a microsecond. When it is necessary to examine a trace long after the stimulus giving rise to it has ended, a screen with a long afterglow of several seconds may be used; such a screen may consist of zinc sulphide with a copper compound as an activator.

8. Screens with Multiple Layers

In general it is found that when a screen has an afterglow of short duration the build-up time for the light to reach maximum intensity is short and the average intensity is high. However, when the screen has an afterglow of long duration the build-up time of the intensity of the light is comparatively long and the average intensity is low. In order to obtain long-afterglow characteristics with a higher average intensity of light it is possible to use a screen consisting of two layers of different fluorescent materials. The electron beam strikes the first layer and causes it to emit ultra-violet and visible blue light. The afterglow duration of this layer is usually a small fraction of a second. The ultra-violet light acts on the second layer (nearer the face of the tube) and causes the emission from it of visible light (usually yellow). The afterglow duration of this layer is of the order of a few seconds. An arrangement of this kind is found to give a comparatively high average intensity of illumination combined with long afterglow. Since it has been arranged in this case that the blue light is of short whilst the yellow light is of long duration, it is possible, with suitable light filters, to arrange for the screen to show the characteristics of either short or long afterglow. Thus if the movement of the spot is viewed through a filter capable of passing blue light only, then the short afterglow is seen. If, however a yellow filter is used, only the long afterglow characteristic is visible.

The use of screens with multiple layers allows for the possibility of distinguishing between these movements of the spot of light which are regularly repeated at a fixed position on the screen and those which are not. This possibility is of great importance in radar applications. Suppose for example that one layer of the screen, with short afterglow characteristics, emits red light when activated, whilst another layer, with long afterglow emits green light. If movements of the electron beam are regularly repeated, with in a period shorter than the duration of the afterglow, and at a fixed position on the screen, the green light can grow in intensity in comparison with the red. If the movements of the beam of electrons are not repeated at the same position on the screen the green light at any one position will not attain any appreciable intensity and the briefer emission of red light will predominate.

9. The Skiatron or Dark-Trace Tube

Screens are also in use whose materials react to the stimulus of the electron beam by a change of colour rather than by fluorescing. This colouration is most marked in the case of certain of the alkali halides, and the final colour obtained varies with the salt used for

the material of the screen. In general the material used is potassium chloride, and the electron beam causes a dark magenta stain where it strikes the white screen.

The staining does not die away instantaneously on the removal of the exciting electron beam. There is in fact an "afterglow" - if such a term can be applied to a dark mark formed on a white background. The rate of the decay of the colour is found to depend mainly on:-

- (i) the initial intensity of the marking on the screen, the decay taking longer, the more intense is the initial mark;
- (ii) the intensity and colour of any light incident on the screen from an external source, the decay being more rapid the greater is the intensity;
- (iii) the temperature of the screen, a rise in temperature resulting in a more rapid decay.

If the face of the CRT is brightly illuminated, it and any dark trace on it can be projected as in an episcoper on to a large ground-glass screen. In this way magnified images of the stains on the face of the tube can be obtained. Mercury light is usually chosen as the illuminant for the screen for two reasons. In the first place, it is rich in the yellowish-green light band, a colour which is approximately complementary of the magenta stain, so that there is good contrast between the colour of the screen and that of the stain. Secondly, light of this colour is the most active in producing the decay of the stains. When the screen is illuminated with a single pulse of intensity of about 70,000 foot-candles of mercury light the stains last for about 10 seconds. For repeated excitation the stains will obviously last very much longer.

The type of tube described above is commonly called a Skiatron.

10. The Glass Envelope

The end of the glass envelope, on which the fluorescent screen is deposited, has a curvature which is consistent with mechanical strength. It is worth noting that the end of a tube of diameter 12 inches carries a load of $\frac{3}{4}$ ton due to atmospheric pressure alone.

FOCUSING SYSTEMS

11. General

The necessity for focusing the electron beam was discussed in Sec. 4. There are three methods available:-

- (i) Electrostatic - with hard tubes.
- (ii) Magnetostatic - with hard tubes.
- (iii) Gas - with soft tubes.

Each of those three methods has its own advantages and disadvantages but (i) and (ii) are in common use in radar whereas (iii) is rarely used.

12. Electrostatic Focusing

This form of focusing utilises the effects of suitably shaped electric fields on the electron beam. The effects are very similar to those obtained when a beam of light passes through materials of

different optical refractive indices. In this connection a new branch of applied science, known as Electron Optics, has come into existence, and many of the terms used are borrowed direct from physical optics.

A ray of light is refracted if it passes from a medium of one refractive index to a medium of another. If the refractive index of the first medium is smaller than that of the second, the ray of light is bent towards the line normal to the boundary of the two media. If an electron, moving with velocity u_1 through a region of constant potential V_1 passes into a region of constant potential V_2 its velocity is altered and its path changes direction at the boundary between the two regions. If u_1 (proportional to the square-root of V_1) is less than u_2 , (proportional to the square-root of V_2) the path of the electron is bent towards the line normal to the boundary: (Fig. 265).

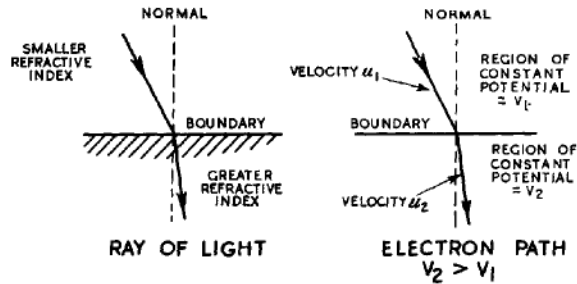

Fig. 265 - Refraction of ray of light and of electron beam.

In most cases considered in electron optics the change of potential from one region to another is gradual and the path of the electron is curved. In Fig. 266 the electron is shown passing through a region of constant potential gradient, the direction of its initial movement making an angle with the lines of electrostatic force. In electron optics the equipotential planes, all at right-angles to the lines of electrostatic force, are equivalent to surfaces of constant refractive index in physical optics. The electron undergoes continuous refraction as it passes through the equipotential surfaces, and if it is moving from regions of lower to regions of high potential, its path always tends to coincide more and more with a direction perpendicular to the equipotential planes. This last statement is true whatever the shape of the equipotential surfaces. In an accelerating field an electron is deflected towards the normal to the equipotential surfaces; in a retarding field it is deflected away from the normal.

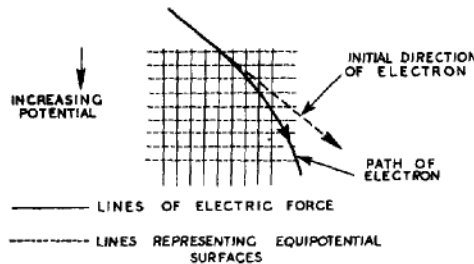

Fig. 266 - Path of electron moving through uniform accelerating electric field.

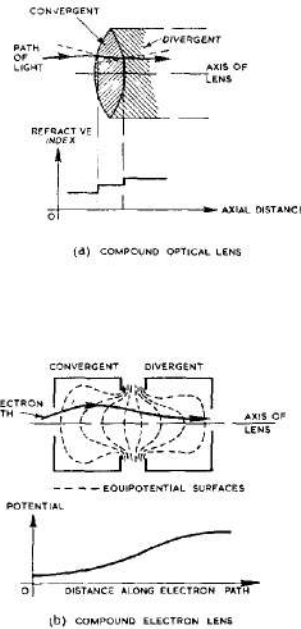
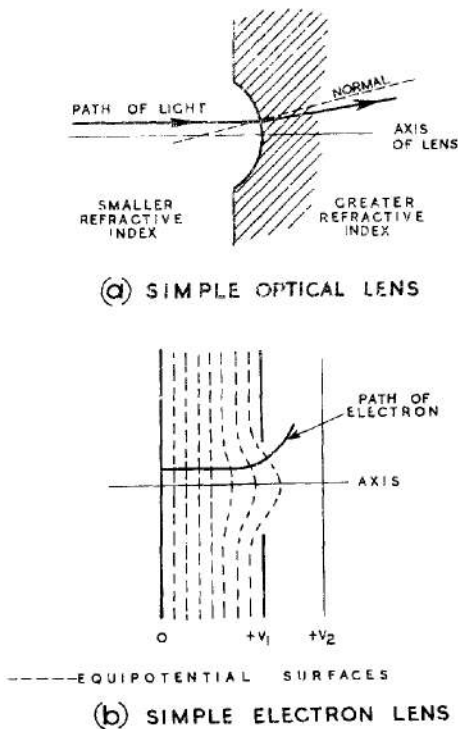

Fig. 267 - Simple lenses; (a) optical (b) electron.

Fig. 268 - Compound lenses; (a) optical (b) electron.

A set of electrodes having rotational symmetry about an axis can be used to produce a symmetrical electrostatic field which has properties, in electron optics, somewhat similar to those of a lens in physical optics. Fig. 267 shows a simple type of electron lens which is produced by placing a plate with a circular hole in it between two other plates and then fixing the potentials of all three so that there are different potential gradients on the two sides of the centre plate. Fig. 268 shows a more complex type of electron lens. This lens is produced by two coaxial cylinders at different potentials. If the potential of the second cylinder is greater than that of the first, the equipotential surfaces are distributed as shown in the diagram. An electron which enters the first cylinder at a small angle to the axis experiences a force towards the axis while it is passing through the first cylinder and on to the second. As the electron enters and passes through the second cylinder it experiences a force away from the axis. The convergent angular deflection exceeds the divergent because the electron remains longer in the convergent portion of the lens, and therefore a given force can deflect it through a greater angle. The resultant converging action of an electron lens consisting of two cylinders depends on the dimensions and relative spacing of the cylinders and on the ratio of their potentials.

The simplest method of achieving electrostatic focusing of the beam in a CRT is shown in Fig. 269. Here the focusing system consists of two cylinders held at different potentials, both positive with respect to that of the cathode. The cylinder nearer the grid (First Anode) is commonly at a potential of the order of a quarter of

that of the other cylinder (Second Anode) with respect to the cathode. The point to which the electron beam is focused is determined by the ratio of the potentials of the first and second anodes. This ratio must be adjusted so that the focal point is brought to the fluorescent screen. This change in the ratio of the potentials on the two anodes is usually obtained by altering the potential of the first anode.

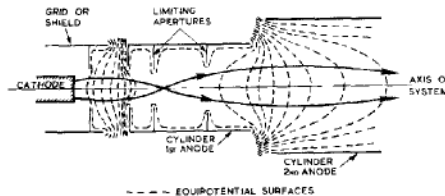

Fig. 269 - Two-anode focusing system of CRT.

With the two-anode system it is found that the controls of focus and brilliance are not independent. Change of voltage of the first anode (focusing) affects the intensity of the beam current (Sec. 6) and, therefore, the brilliance, whilst adjustment of the voltage of the grid alters the focusing to a small extent. This is to be expected when it is realised that any change of potential of any electrode will affect the potential ratios and accordingly modify the focusing of the electron beam.

When, as is usual in radar applications, it is required to produce a sharp spot whose focus is almost independent of the brightness-control, a three-anode focusing system is used (Fig. 270). It differs from the two-anode type by the addition of an extra anode on the side nearer to the grid.

This new electrode is called the first anode and is commonly, but not always, kept at the same potential as the third anode, nearest the screen. The middle electrode, or second anode, is usually at an appreciably lower potential, about one-third or one quarter of that of the two other electrodes, relative to the cathode. Focusing is usually obtained by a variation of the potential of the second anode.

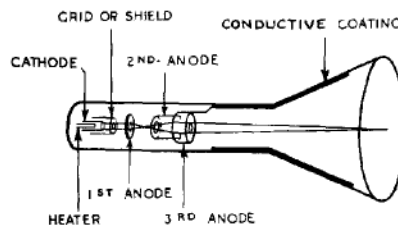

Fig. 270 - Three-anode focusing system.

The additional anode, between the grid and the focusing anode, can be compared to a certain extent with the additional grid which converts a triode to a tetrode. Variations in the electric fields on the side of the additional electrode remote from the cathode are thereby screened and have little effect on the field near the cathode. Thus, variation of the potential of the second anode of a focusing arrangement does not appreciably affect the intensity of the beam current, i.e. the brilliance. The presence of the first anode also minimises the small effect of changes of grid potential on the focusing system formed by the second and third anodes. A further advantage of the three-anode system lies in the relative independence of the deflection system on the focusing arrangements. In the two-anode tube variation of the first anode is liable to vary the velocity of the electrons between second anode and screen, and hence to affect the deflectional sensitivity.

The size of the spot obtainable by the above method is directly related to the accelerating potential used. If the potential difference between the third anode and cathode is low no amount of juggling with electrode design or relative potentials can produce a sharply focused spot. Typical potentials at the electrodes of a three-anode CRT, whose screen diameter is 12 inches, are as follows:-

Cathode	- 4000 V.
Centrel electrode	- 4010 to -4050 V. (variable brilliance).
Second anode about	- 3000 V. (variable focus).
First and third anodes	0 V.

The customary use of negative electrode potentials is explained in Sec.27.
 13. Magnetostatic focusing

In magnetostatically focused tubes there are no focusing electrodes inside the tube. A steady magnetic field is directed along the axis of the tube by means of a coil, supplied with direct current (or possibly by means of permanent magnets) mounted round the neck of the tube beyond the anode, (Figs. 271 and 272).

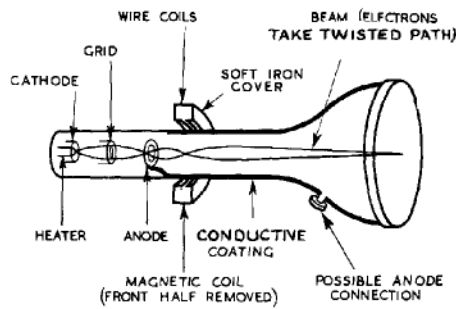

Fig. 271 - CRT with magnetostatic focusing.

Two methods are possible:-

- (i) Using a uniform axial field.
- (ii) Using a non-uniform field with large radial components.

Method (ii) is the one used in practice.

Consider an electron of charge e moving with velocity u at right angles to a magnetic field H . The electron will experience a force Heu at right angles both to the field and direction of motion (Fig. 272).

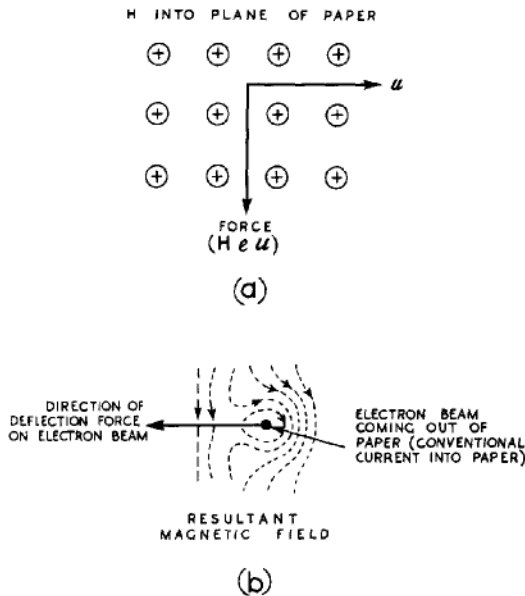

Fig. 272 - Force acting on an electron moving in a magnetic field.

This force may be considered as generated by the interaction of the applied field H and the magnetic field due to the electron current, as illustrated at (b).

It is this force on an electron travelling in a magnetic field which is utilised in magnetostatic focusing. The field used is axially symmetrical and is produced in practice by placing a coil inside a soft iron cover with gap. When current flows through the coil the field produced is similar to that produced by the two annuli of north and south polarity; (Fig. 273). A and B are neutral points.

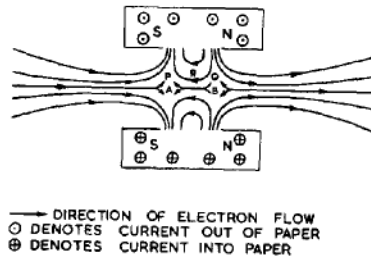

Fig. 273 - Magnetostatic field of focusing coil.

Before discussing the focusing action of the coil, we note that:-

- (i) in their travel from cathode to screen the electrons spend most of the time in space which is free from magnetic fields of significant magnitude.
- (ii) the electrons are moving with a high velocity along or very near to the axis. Hence only a radial component of the field will produce an appreciable deflecting force in such a direction as to cause the electron to spiral about the axis.

Observation of the lines of force reveals that there are two regions P and Q where the radial fields are relatively large. Near the axis the radial component is bound to be approximately proportional to the distance from the axis. The space R between P and Q contains a large axial magnetic field and near the axis this will be virtually constant. A simplification of such a magnetic field is shown in Fig. 274. A non-axial electron entering region P will start rotating about the axis.

When it leaves P it will have attained an angular velocity proportional to its distance from the axis. In the figure this velocity will be into the plane of the paper above the axis. In region R this velocity being perpendicular to the axial field will cause the electron to move towards the axis. Thus on leaving region R in addition to its rotation about the axis the electron will have a radial component of velocity. This radial component will be proportional to the angular velocity with which the electron entered the region R. Thus the radial velocity will be approximately proportional to the distance of the electron from the axis on entering P.

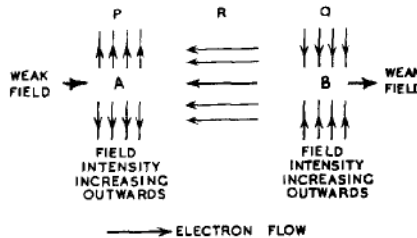

Fig. 274 - Idealised magnetostatic focusing field.

The electron now enters region Q. The radial field here can have no effect on the radial velocity but it will reduce the angular rotation; since the total inward flux at Q is equal to the total outward flux at P the ultimate angular velocity will be zero, but usually

rotation of the image exists. Thus an "off axis" electron leaves the field with a velocity towards the axis. This velocity is proportional to its distance from the axis on entering the field. It can be shown that, provided the disposition and intensity of the magnetic field are suitably adjusted, all the electrons diverging from a point on the axis outside the field will after passing through the field converge to another point on the axis.

Broadly speaking, at A of Fig. 275 there is twice the divergence at B, but the electron is twice as far from the axis so that the radial velocity after passing through the field will be twice as much.

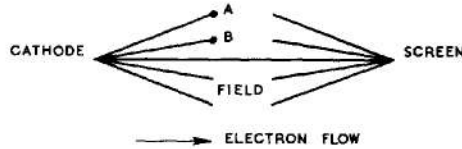

Fig. 275 - Direction of electron paths entering and leaving focusing field.

By suitable adjustment of the position of the coil and the current through it the focal point at which the electrons converge can be brought to the screen of the CRT.

14. Gas Focusing in Soft Tubes

A small quantity of inert gas such as argon or helium, admitted after the tube has been fully evacuated, provides the focusing action of the electron beam. The grid potential is usually about 50 volts below that of the cathode and practically all the emitted electrons go through the hole in the anode as a beam of small divergence. The cathode potential is normally between 300 and 500 volts negative with respect to the anode.

As the electrons pass along the tube from the grid, many collide with the gas molecules, and ionise them so that electrons are ejected and comparatively heavy and slow-moving ions are left behind. The positive ions form a core which exerts a considerable attractive force on the negative electrons. Provided the number of ions formed is sufficiently great the mutual repulsive force of the electrons is more than counterbalanced, and it is possible to converge the stream to give a spot on the screen of less than 0.5 mm. diameter.

The comparatively short life and dependence of focus on brilliance in soft tubes using gas focusing makes them unsuitable for most radar applications. Also, the inertia of the positive ions introduces a lag in the focusing action so that for rapidly varying deflection voltages the focus is impaired. Soft tubes, however, have the advantage that intensity of illuminations of the screen can be accomplished with a low accelerating potential. External power supplies are, therefore, simplified, and since the electrons are moving comparatively slowly, they can be deflected easily. Such advantages explain the use of soft tubes in some types of oscillograph, but even here they are being replaced by hard tubes using electrostatic or magnetostatic focusing.

DEFLECTION SYSTEMS

15. General

It is necessary that the electron beam should be deflected after it leaves the final anode. In its simplest form the deflection system is such that the beam of electrons can be deflected to and fro in a direction at right-angles to that of the beam.

There are two types of deflection systems, electric and magnetic; these systems are applicable to both soft and hard tubes.

16. Electric Deflection

An electron situated in a uniform electric field experiences a force in the direction of the field. Consequently a beam of electrons passing through a transverse electric field will be deflected. This deflection is usually obtained by applying a potential difference to a pair of parallel plates so situated within the tube that the beam passes between them shortly after it emerges from the focusing field; (Fig. 276). The beam experiences a force proportional to the field strength and therefore to the potential difference between the plates. It is bent towards the more positive of the two plates and the velocity component which the electrons acquire, at right angles to the axis of the tube, persists after they leave the deflector plates until they hit the screen. If the potential difference between the deflector plates is constant the beam is permanently deflected. Steady potential differences called Shift Voltages are used to adjust the initial position of the spot of light on the screen. If an alternating potential difference is applied to the plates, the spot is swept to and fro across the tube and, if the frequency is sufficiently great, persistence of vision will cause it to appear on the screen as a trace.

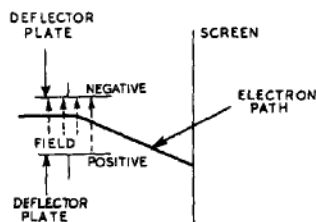

Fig. 276 - Deflection of electron by pair of parallel plates.

It is possible to obtain deflections in two perpendicular directions by mounting two mutually perpendicular sets of parallel plates in the neck of the glass envelope, (Fig. 277), one set of plates being mounted nearer the screen than the other. These two sets of plates are called the X and Y plates, to indicate the directions of the two deflections relative to the structure of the tube. To allow for the deflection of the beam, the plates are not usually parallel throughout their whole length but usually diverge towards the screen. The width of the second pair of plates (the pair nearer the

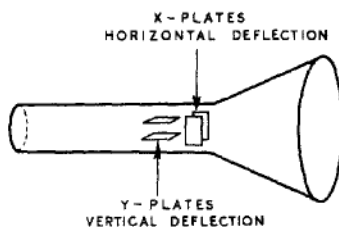

Fig. 277 - Deflector plate assembly.

screen) is larger than that of the first pair to allow for the deflection of the beam by the first pair. It is possible, by the application of suitably varying voltages to the two pairs of plates, to produce a trace at any desired inclination to the X and Y axes.

The deflection sensitivity of a CRT employing electric deflection is given by the deflection of the spot in millimetres for a potential difference of one volt between the two deflector plates. This deflection is found to be inversely proportional to the potential difference between the cathode and final anode, on the assumption that the mean potential of the deflector plates is the same as that of the final anode. Soft tubes are normally operated at much lower anode potentials than hard tubes, so their electric deflection sensitivity (about 0.5 mm/V.) is usually greater than that of hard tubes (about 0.2 mm/V.)

Derivation of Electric Deflection Sensitivity (Fig. 278)

Let:-

- l be the length of the deflector plates,
- t the distance between the plates,
- S the length of the tube from the centre point of the deflector plates to the screen,
- e the magnitude of the charge on an electron,
- m the mass of an electron,
- V_a the potential difference between the final anode and the cathode of the CRT,
- V_p the potential difference between the plates,
- u the velocity of an electron on entry.

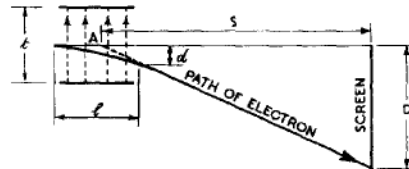

Fig. 278 - Electron undergoing electric deflection.

The field-strength between the plates = $\frac{V_p}{t}$

The force on an electron = $\frac{V_p \cdot e}{t}$

Since force = mass x acceleration then the acceleration of the electron towards the positive plate = $\frac{V_p \cdot e}{t \cdot m}$

The time the electron is moving between the plates = $\frac{l}{u}$

Since displacement = $\frac{1}{2}$ acceleration x (time)² then the transverse displacement at the end of the plates is given by $d = \frac{1}{2} \cdot \frac{V_p \cdot e}{t \cdot m} \cdot \frac{l^2}{u^2}$

But the kinetic energy of an entering electron = $\frac{1}{2} mu^2$ = loss of potential energy as it passes from cathode to final anode = $e \cdot V_a$, so that $mu^2 = 2e V_a$.

$$\text{Therefore } d = \frac{l^2}{4t} \cdot \frac{V_p}{V_a}$$

Since the deflecting force is at right angles to the axis of the tube (initial direction of motion of electron) the electron path is parabolic and the point A, the apparent origin of the deflected beam, is halfway along the plates.

Therefore the displacement on the screen is given by

$$D = \frac{ds}{\sqrt{2}}$$

$$= \frac{l^2}{4t} \cdot \frac{2s}{l} \cdot \frac{V_p}{V_a}$$

Then the displacement on the screen per unit of potential difference between deflector plates, i.e. the deflection sensitivity, is given by $\frac{D}{V_p} = \frac{l s}{2 \cdot t \cdot V_a}$

For a given tube and plate dimensions, the deflection sensitivity is inversely proportional to V_a (potential difference between the cathode and final anode). Since $V_a \cdot e = \frac{1}{2} mu^2$ the deflection sensitivity is inversely proportional to the square of the velocity (u) of the electron.

For a given value of V_a , the closer the plates, or the longer their length, or the longer the tube from the plates to the screen, the greater is the deflection sensitivity. The use of a long tube, however, introduces difficulties in producing a good focus. The focusing system has no control over the electron beam once it has left the system and, due to the mutual repulsion of the electrons, the more remote the screen the less sharp will be the focus. Hence a compromise is necessary between good focus and high deflection sensitivity.

17. Magnetic Deflection

It is often convenient to produce the deflection of the electron beam by a transverse magnetic field. This is produced by a pair of similar coils, one on each side of the neck of the glass envelope. These two coils are in series and are so wound that they produce a magnetic field in the same direction across the neck of the glass envelope. Alternative arrangements are shown in Fig. 279. The field is perpendicular to the direction of the electron beam so that the deflection is at right angles both to field and beam (See Sec. 13)

A steady current through the pair of coils produces a constant deflection of the spot; an alternating current sweeps the spot to

and form a trace. Since the deflection is a radial one, perpendicular to the direction of the field, the location of the spot on the screen depends on the position of the coils.

A second pair of coils at right-angles to the first pair deflects the spot in a direction perpendicular to that of the deflection due to the first pair of coils. (Fig. 280). By supplying each pair of coils with a suitably varying current a trace can be produced at any desired inclination to the X and Y axes.

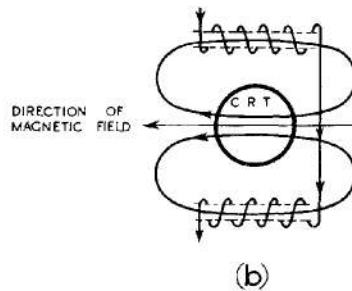
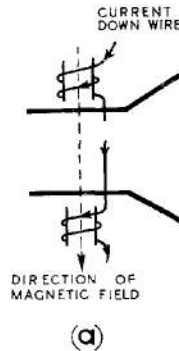

Fig. 279 - Alternative methods of producing magnetic deflection.

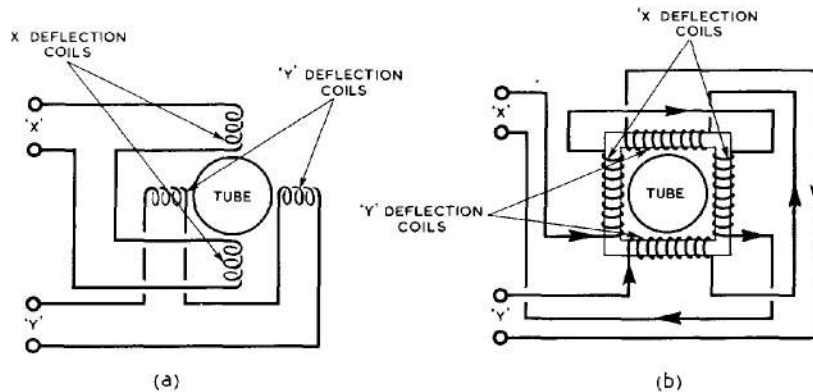

Fig. 280 - Coil assembly for producing magnetic deflection.

With magnetic deflection the deflection sensitivity is found to be inversely proportional to the square root of the potential difference between final anode and cathode. Thus the deflection sensitivity with magnetic deflection of soft tubes (low anode voltage) is greater than with hard tubes (high anode voltage) but the difference is not so marked as with electric deflection where the deflection sensitivity is inversely proportional to the potential difference

between cathode and final anode.

Derivation of Magnetic Deflection Sensitivity (Fig. 281)

If an electron moves into a uniform magnetic field so that its direction of motion is at right angles to the field, it will experience a force perpendicular both to the field and to the motion.

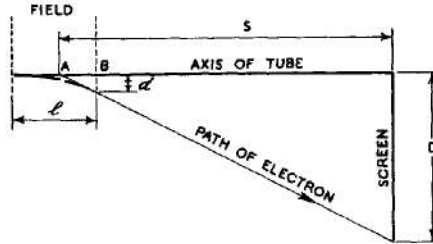

Fig. 281 - Electron undergoing magnetic deflection.

Let m be the electronic mass,

e be the electronic charge,

H be the magnetic field strength,

V_a be the potential difference between final anode and cathode of the CRT,

l be the extent of the magnetic field (assumed uniform),

s be the distance to the screen from A, the apparent origin on the axis of the deflected beam; (this is approximately the centre of the field),

u be the electron velocity.

Then the force on the electron is Heu ,

so that the acceleration is $\frac{Heu}{m}$.

If this force acts for a time t , this causes the electron to be deflected a distance $d = \frac{1}{2} \left(\frac{Heu}{m} \right) t^2$.

Since $t = \frac{l}{u}$, this gives $d = \frac{1}{2} \frac{Heu}{m} \frac{l^2}{u^2}$,

$$= \frac{He l^2}{2 mu}$$

The deflection D of the spot on the screen is then given by $D = \frac{s}{AB} d$.

If we take AB approximately equal to $\frac{l}{2}$, this becomes $D = \frac{s}{l/2} \frac{He l^2}{2mu}$

$$= \frac{l s He}{mu}$$

Writing $\frac{1}{2} mu^2 = eV_a$, we have

$$u = \sqrt{\frac{2e V_a}{m}}$$

so that $D = l_s H \sqrt{\frac{e}{2m V_a}}$.

Hence the deflection sensitivity, $\frac{D}{H}$ is given by

$$\frac{D}{H} = l_s \sqrt{\frac{e}{2m V_a}}$$

For given tube dimensions and arrangement of coils the deflection sensitivity is inversely proportional to the square root of V_a . Alternatively it is inversely proportional to the velocity of the electron.

For a given V_a , the longer the tube from the coil to the screen or the more extensive the field, the greater is the deflection sensitivity. The use of a long tube, however, leads to a deterioration of focus.

In practice magnetic deflection sensitivity is often measured in millimetres per milliamp of current through the coils instead of per unit of magnetic flux.

DISTORTIONS AND THEIR CORRECTION

18. Trapezium Distortion

Trapezium distortion can occur in all CRTs in which electric deflection is utilised, but it is more apparent with hard tubes since in these much higher voltages must be applied to the deflector plates to produce full scale deflection. This distortion arises because the potentials of the deflector plates nearer the screen, say, the X-plates may affect the deflection sensitivity of the other pair, the Y-plates.

If the movements of the spot fill the face of the tube as in television and in certain radar displays the effects of trapezium distortion are most noticeable. The rectangular picture (or Raster) is altered to a trapezium, shown dotted in Fig. 282, thereby giving the name to this type of distortion.

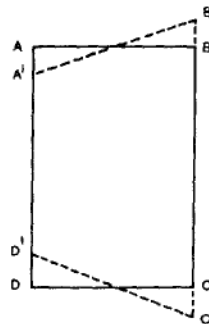

Fig. 282 - Trapezium distortion.

It has been thought that trapezium distortion is due to the interaction between the electric fields of the two pairs of plates. However, it can be shown that it can be produced if only one pair of plates is used, the deflection at right-angles being caused by magnetic means. If the electric deflection system is nearer the screen than the magnetic deflection system trapezium distortion can occur.

Consider the Y-deflection to be produced magnetically. Suppose a positive potential of, say, 500 V. is applied to the upper

X-plate (Fig. 283(a)), the lower plate being earthed, as are the final anode and glass envelope. The equipotential surfaces will be distributed in a manner similar to that illustrated. Now consider them cut by a plane mid-way between the X-plates and containing the beam, which has already been deflected magnetically in the Y-plane. This cross section is illustrated at (b). The field distribution acts as an electronic lens (see Sec. 12), the beam being deflected towards the normal to the equipotential surfaces on entering (accelerating field) and away from the normal on leaving (retarding field). Thus in the case illustrated the Y-deflection is decreased by the X-plate potential distribution. Similarly it may be shown that if one of the X-plates is negative with respect to the final anode the Y-deflection is increased.

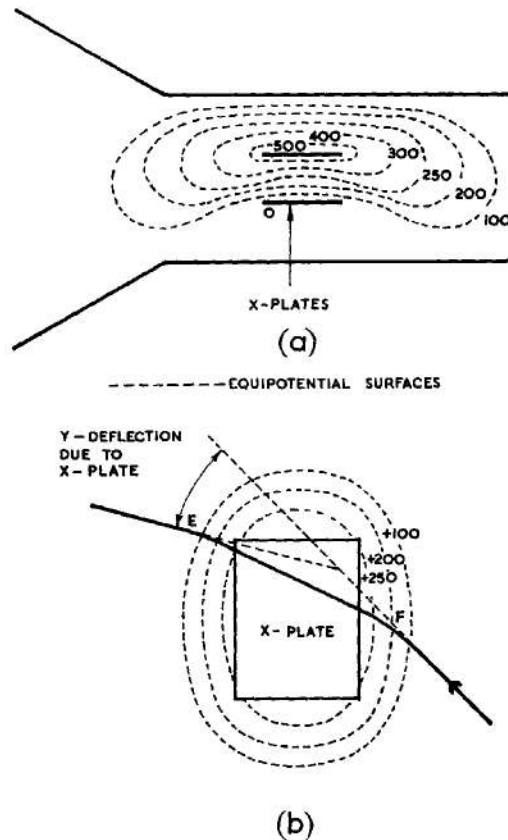

Fig. 283 - Cause of trapezium distortion.

If electric deflection is used for both X- and Y-displacements, the application of deflecting potentials to the Y-plates modifies the appearance of the field produced by the X-plates; but even when this action is taken into account, the lens field produced by the X-plates still alters the Y-deflection in a manner similar to that described above.

One method of reducing trapezium distortion is to use a balanced deflection voltage for the pair of plates, say X-plates, nearer the screen. If the deflecting potential applied to one plate at any instant is equal in magnitude and opposite in sign to that applied to the other, the potential of the space midway between the plates in the path of the beam is approximately constant and the Y-deflection is not altered.

Alternatively deflector plates corrected for trapezium distortion may be used (e.g. if the tube is used in a double-beam

oscilloscope). The pair of deflector plates nearer the final anode is so assembled that the plate separation is not constant; that is, the plates are not parallel. Hence the deflection sensitivity depends upon whether the beam traverses the region between these plates at a point where the plate separation is small or great. In the former case the sensitivity is greater than in the latter. So if the plate separation is correctly tapered, compensation for trapezium distortion can be achieved.

Another method is to shape the plates nearer the screen (X-plates) so that these plates produce a deflection which has a component in the Y direction so that the trapezium distortion effect is counteracted. This method is illustrated in Fig. 284(a), where the X-plates are shown to be curved. The arrows indicate the direction of deflection produced by the X-plates. A practical example of shaped X-plates is shown in Fig. 284(b); the equipotential lines (shown dotted in the diagram) are curved and the effects are similar to those obtained with curved X-plates.

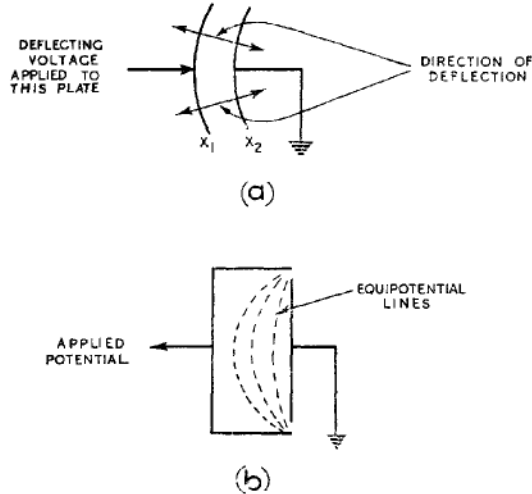
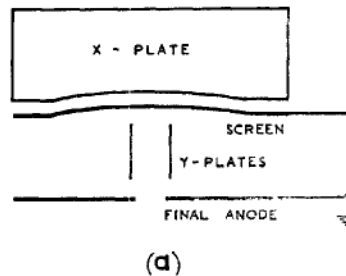

Fig. 284 - Shaped plates to eliminate trapezium distortion.

It should be noted that if this method for correcting trapezium distortion is employed it operates only if the deflecting voltages applied to the plates nearer the screen are unbalanced and also only if the correct plate is earthed (connected to the final anode).



A more satisfactory method for correction of trapezium distortion is shown in Fig. 285. By shaping the X-plates as shown the equipotential lines at F (Fig. 283(b)) can be made concave as seen from the final anode. Then if the potential distribution is such as to cause the beam to be deflected towards the normal at F

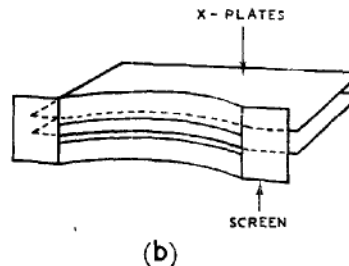

Fig. 285 - Alternative method for correcting for trapezium distortion.

it will be deflected away from the normal at E, so that the deflection introduced is outwards at F and inwards at E. A similar argument holds if the field at F is retarding instead of accelerating. The opposing deviations of the beam at F and E can now be balanced by correct shaping of the plates and trapezium distortion can be avoided.

The shaped and slotted screen, which is connected to the final anode and placed between the X- and Y-plates (Fig. 286) is necessary; otherwise the equipotential lines tend to bulge into the space between the Y-plates.

This correction method does not affect the symmetry of the X-plates and balanced deflection potentials may be applied or alternatively either X-plate can be earthed.

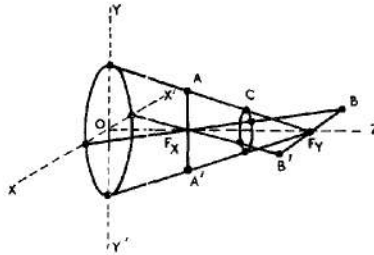

Fig. 286 - Astigmatism produced by optical lens.

With magnetic deflection, if the field due to a pair of deflector coils is not uniform across the neck of the CRT, the distance the spot moves when on one side of the screen will not be the same as when it is on the other. Such an arrangement will produce a distortion similar in appearance to trapezium distortion.

19. Deflection Defocusing

The speed of the electrons in the region of the deflection system depends upon the potential difference between the deflection system and the cathode. It is important that this should remain constant since a variation in speed would move the focus off the screen. If unbalanced voltages are applied to the deflector plates the mean potential of the deflection system does not remain constant and defocusing may occur. Thus if the focus is correctly adjusted at the centre of the screen it deteriorates as the distance from the centre increases. This phenomenon is called deflection defocusing and may be avoided by the use of balanced deflection voltages or by magnetic deflection.

20. Astigmatic Distortion

In order to understand the meaning of the word astigmatism consider first the focusing of an ordinary light beam by passage through a convergent lens. (Fig. 286). If the lens is symmetrical about the axis OZ the amount of convergence is equally great in all axial planes, and a sharp spot of light is produced in the focal plane. If the convergence is a maximum in the plane $XX'Z$ and a minimum in the plane $YY'Z$ then the beam will be converged to a line focus at two positions AA' and BB' , these lines being in mutually perpendicular directions. The best focus obtainable is at C where the beam is converged to a circular focus, but of finite size. This type of defect often occurs in the lens of the eye and gives rise to the defect of vision known as astigmatism.

In a cathode ray tube it sometimes happens that the electric lens is asymmetrical due to misalignment of the electrode system

in the tube. When this occurs it is found that manipulation of the focusing control produces a sharp line on the screen in one or other of two perpendicular directions, or a circle of finite size, but never a small sharply defined spot. This fault is said to be due to the presence of astigmatism in the tube.

Astigmatism can be corrected by having the mean potential of each pair of deflector plates separately adjustable at a value other than that of the final anode. This mean potential of a pair of plates should be independent of shift voltages and variable deflection voltages. Such an arrangement introduces deliberate distortion into the electric fields between the electrodes so as to counterbalance the distortion producing the astigmatism.

21. Bulb Charge and Deflector Plate Current

When the main electrons in the beam strike the screen they eject secondary electrons from it and it is these secondary electrons travelling to the anode which make the major contribution to the anode current. The potential of the screen becomes negative to that of the anode by an amount sufficient to ensure that equilibrium conditions are set up, i.e. the rate at which secondary electrons leave the screen to go to the anode is the same as the rate of arrival of the primary electrons at the screen. The potential difference developed is of the order of 100 volts.

With some tubes the screen picture disappears if the glass of the screen is touched. This minor defect is due to the induction of a large negative charge on the screen, sufficient to repel the beam electrons so that they never reach it. The picture will reappear after a short time, working its way back from the edges of the screen inwards, as the charge leaks away.

The electrons returning from the screen should pass to the final anode which is normally at earth potential. If, however, the steady potential of a deflector plate is positive with respect to earth, electrons are drawn to this plate. This effect may be likened to the flow of grid current in the input circuit of a valve amplifier (Chap. 9, Sec. 3). The non-linearity which is introduced in either case by the flow of current does not produce appreciable distortion unless the input resistance of the deflection system or valve circuit is sufficiently small as to be comparable with the output resistance of the source of voltage.

Errors due to deflector plate current distortion can therefore be reduced by feeding the deflector plates from a source of low output resistance, e.g. from a cathode follower. The electron current drawn by the deflector plates can be minimised by constructing the electrodes in such a manner that the deflector plates are shielded by the final anode, or by arranging that the maximum potential applied to any deflector plate does not rise appreciably above final anode potential (this latter method is not usually practicable).

22. Stray Fields Leading to Distortion

Alternating magnetic fields from components such as transformers and chokes act on the electron beam and may lead to an oscillatory motion of the spot so as to draw it out into a line or ellipse. The effect can be distinguished from normal defocusing because it is not removed by alteration of the focusing controls. In some cases the earth's magnetic field may introduce a deflection which varies in magnitude and direction as the position of the tube is changed relative to the earth's field. The usual way of overcoming the effect of stray magnetic fields is to surround the tube

with a mu-metal shield. If the shield is also earthed it protects the beam from any stray electric fields which may be set up by nearby apparatus.

23. COMPARISON OF FOCUSING AND DEFLECTION SYSTEMS

For small tubes with screens up to about 5 in. in diameter, it is usual to employ electrostatic focusing and electric deflection systems. This arrangement is convenient since it avoids the use of deflection equipment outside the tube. If electric deflection is used with larger tubes, involving high accelerating voltages, it is necessary to place the deflector plates of each pair close together in order to obtain reasonable deflection sensitivity. However, if the plates are too close together there is a danger that the beam of electrons will strike the edge of a plate before full deflection can occur so that the beam will be cut off from the screen. This effect can be minimised by increasing the plate separation towards the screen, but this arrangement has limitations and the method of deflection by magnetic fields is probably preferable.

When magnetic deflection is used it is important that the deflecting field, over the area of cross-section of the neck of the tube, be uniform in order to avoid errors of defocusing. One way of ensuring that the field is as uniform as possible is to make the area of cross-section as small as possible. If this is done it is often convenient to use magnetostatic rather than electrostatic focusing since the latter involves the insertion of a complex electrode system inside the neck of the tube. There is always the danger that the electrodes in an electrostatic focusing system may be misaligned. This fault will give rise to astigmatism which can usually be corrected, but only at the expense of fairly complex external circuits. A magnetostatic focusing system can be adjusted in position to avoid such astigmatism. However, it is not a simple matter to adjust a focus coil in position so as to be sure of obtaining the best possible focus attainable, and in spite of the possible disadvantages outlined above electrostatic focusing systems are often preferred.

24. POST-DEFLECTOR ACCELERATION

To avoid the difficulty, inherent in the normal hard tube, of poor deflection sensitivity, tubes are sometimes used in which a large part of the acceleration of the electrons takes place after they have been deflected. It is then possible to arrange that the beam is deflected when at low velocity so as to give a good deflection sensitivity, and yet for the beam to have a large velocity when it strikes the screen so that a bright trace is obtained. A tube of this type is shown in Fig. 287 and involves the use of an extra anode in the form of a narrow ring of aquadag coating on the glass envelope

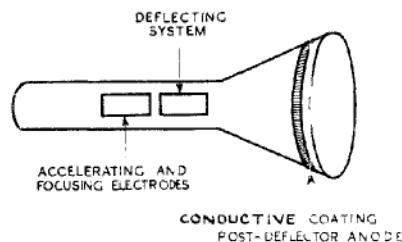

Fig. 287 - Extra electrode assembly for post-deflector acceleration.

just before the screen. This anode is usually maintained at about twice the potential of the last anode of the normal accelerating system. This method of working is called Post-Deflector Acceleration.

25. DOUBLE-BEAM TUBE

This is a tube of special construction in which the beam, after leaving the final accelerating anode, impinges on the edge of a splitting plate placed midway between the Y-plates. The splitting plate is connected to the final anode which is at earth potential. The beam is thus split into two sections (Fig. 288) each of which can be deflected almost independently in the Y-direction by voltages applied between Y_1 and earth and Y_2 and earth. As might be expected, the potentials applied to, say, the Y_1 plate affect to some extent the Y_2 trace and vice versa. A positive voltage at the Y_1 -plate produces an upward deflection of the spot whilst at the Y_2 -plate it produces a downward deflection. Both beams traverse the X-plates in the usual way, and are deflected simultaneously in the horizontal direction. This tube is of particular use in an oscillograph where it is desired to examine two potentials simultaneously.

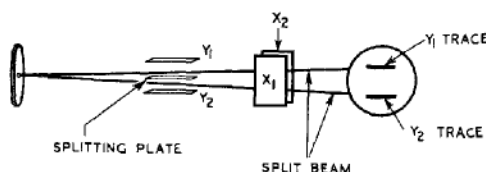

Fig. 288 - Electrode assembly to produce double (or split) beam.

It is possible by the use of external circuits to produce a double trace on an ordinary tube. Here the X-movement of the spot is made to occur successively first across, say, the lower half of the screen, and then across the upper. In this case corresponding vertical displacements on the two traces do not occur simultaneously.

POWER SUPPLIES AND SHIFT NETWORKS

26. General

Steady potentials are required for the various electrodes of a cathode ray tube. Thus, for a three-anode tube with electrostatic focusing, steady potentials are needed at the cathode, grid and the three anodes. A tube with magnetostatic focusing normally requires steady potentials for cathode, grid and one anode, and also a supply of direct current for the focus coil. Electric deflection

involves steady potentials for use as shift voltages so that the picture traced on the CRT screen may start from a convenient point. Magnetic deflection needs direct currents for producing shifts.

27. Power Supplies

The power supply for an electrostatically focused tube should be capable of supplying high voltages of the order of 5000 volts for a large tube, but need supply only a small current. The total load current taken by the CRT is usually less than $\frac{1}{2}$ mA. Half-wave rectification is therefore all that is necessary, and the smoothing circuit of the power unit can employ a resistor, rather than a choke. The high voltages required for the larger CRTs may be obtained by means of voltage-doubler circuits.

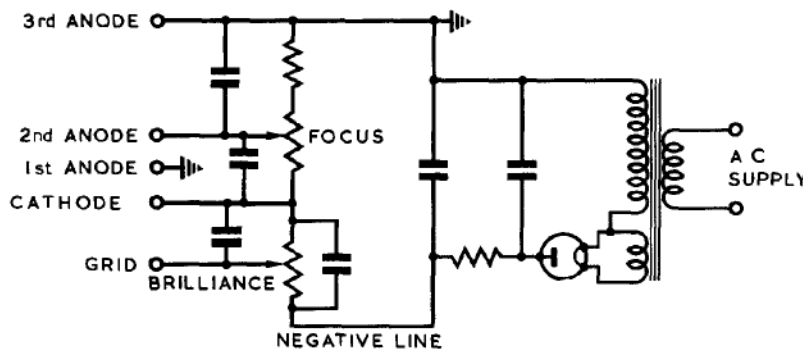

Fig. 289 - Supply circuit for three-anode CRT.

It is advisable to have condensers across all points of supply which are connected to the tube, otherwise a voltage ripple on the supply might be communicated to the electrodes so as to cause variations in brilliance or focus of the trace. A typical supply circuit, suitable for a three-anode electrostatically focused CRT (or for the anode, cathode and grid of a tube with magnetostatic focusing) is shown in Fig. 289.

As shown in Fig. 289 the third anode is at earth potential whilst all other electrodes shown are at negative potentials. This is because the deflector plates in a tube with electric deflection are connected to circuits in which it is convenient (but not essential) to have them at or about earth potential. In order to avoid strong electric fields between these plates and the final anode, this anode itself must be at earth potential.

Another reason for earthing the final anode is that the potential of the fluorescent screen is usually about 30 to 100 volts negative with respect to that of the final anode. If the cathode is earthed the screen is thereby maintained several hundreds or thousands of volts above earth so that strong electrostatic fields may exist between the screen and neighbouring conductors. This can

result in extraneous deflections of the spot if these conductors are moved. If the anode is earthed the cathode and its associated heating circuit must be well insulated from earth.

28. Shift Voltage for Electric Deflection Systems

The shift voltages are usually, but not always, applied to a pair of plates so that the mean potential of these two plates is the same as that of the final anode of the tube. This arrangement avoids trapezium and defocusing distortions, provided that any fluctuating voltages applied to the plates are also balanced. The shift voltages may be obtained either from the power supply which provides steady potentials to other electrodes of the tube (Fig. 290) or from a separate power supply. One deflector plate of a pair is always maintained as much positive, compared to the final anode potential, as the other is negative, so that the mean potential of the pair of plates is that of the final anode. Condensers C bypass to earth any ripple on the shift voltage supplies.

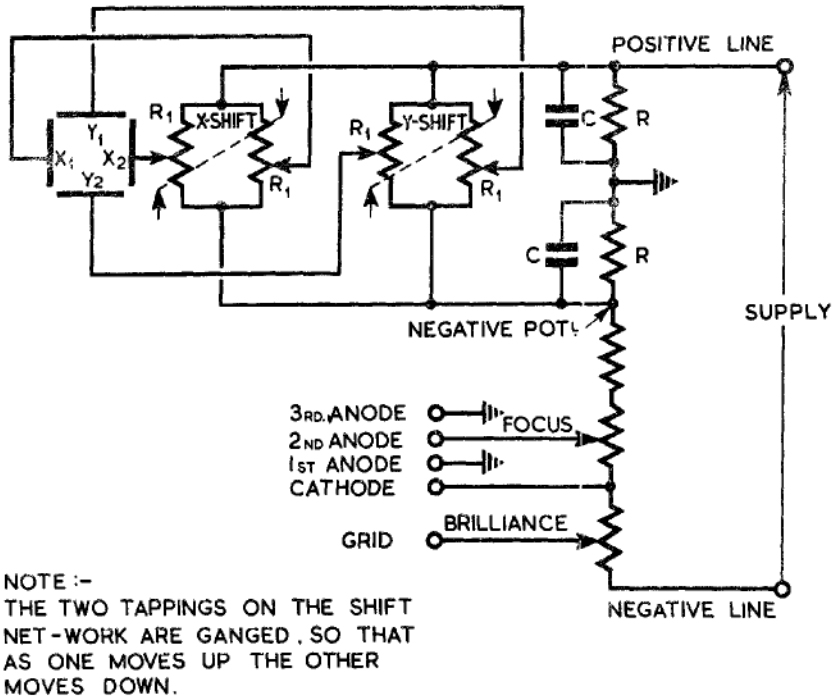

Fig. 290 - Supply for CRT showing production of shift voltages.

Each deflector plate must be connected, usually through a resistance of about two megohms (R and part of R1 in Fig. 290) to the final anode (earth potential); this connection fixes the mean level of the deflector plates and is analogous to the use of a grid leak for determining the bias level in a valve amplifier circuit.

It is common in radar applications, involving the use of large CRTs to adjust the mean potential of each pair of plates with respect to the anode so that astigmatic distortion may be eliminated. The mechanism which provides this adjustment is called the Stig Control. A method is shown in Fig. 291.

A separate similar arrangement provides shift voltages and astigmatic correction for the X-plates.

In the figure, R_2 and R_3 are similar variable resistors forming the Stig Control so ganged that as R_2 is decreased in value R_3 is increased by the same amount, and vice versa. Thus, the mean value of the potential on a pair of plates is raised or lowered above or below earth potential (final anode potential).

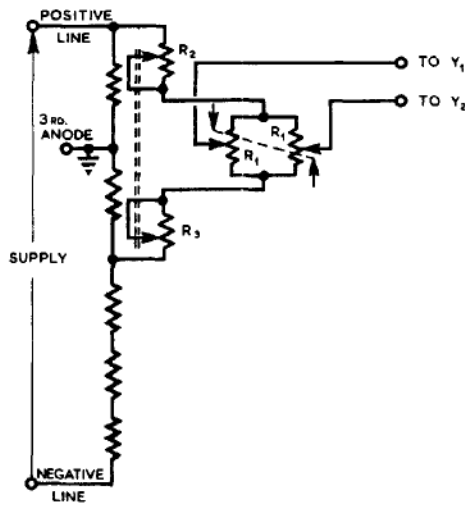

Fig. 291 - Supply network showing Y shift and Y stig. control.

A simple type of shift network which is sometimes used with small CRTs is shown in Fig. 292. Here no attempt is made to keep the mean potential of the deflector plates the same as that of the anode, nor is any attempt made to correct for astigmatism. It is also assumed that the power supply is being used for other sections of radar equipment, so that it is convenient to earth its negative line.

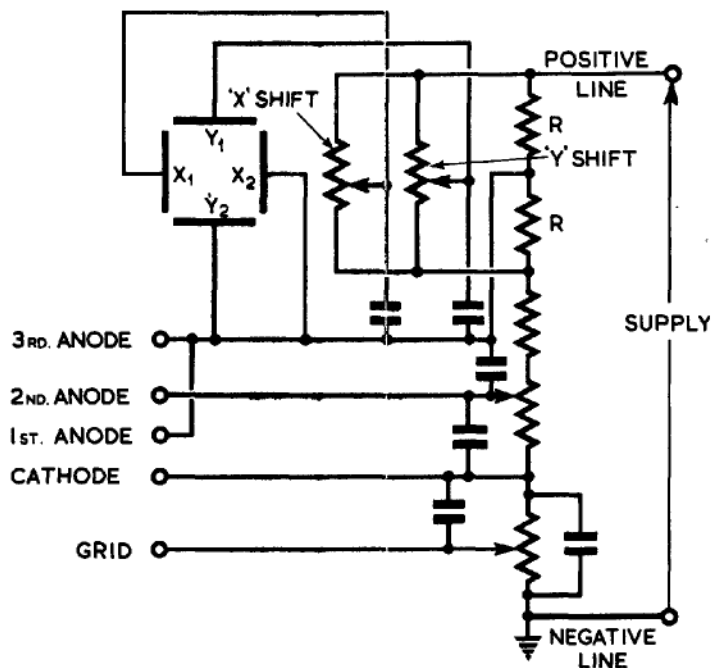

Fig. 292 - Shift network for CRT with negative supply line earthed.

29. Shift Current for Magnetic Deflection Systems

A direct current through the deflector coils is necessary to obtain shift when magnetic deflection is used on a CRT. In most applications it is not essential that the shift should be made to work both ways and a simple arrangement such as is shown in Fig. 293 is adequate.

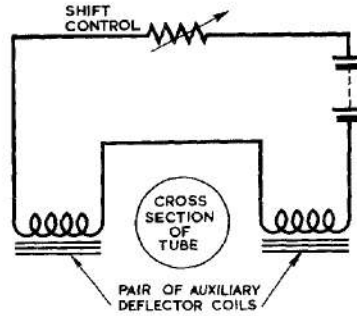

Fig. 293 - Shift control for magnetic deflection.

INPUT CIRCUITS

30. Input Circuits to Deflector Plates

The arrangements for applying input voltages to the deflector plates depends on the source of the input, and on whether shift voltages are also required. An invariable rule is that the mean potential of each pair of plates must be near that of the final anode. Fig. 294 shows a simple arrangement with no shift voltages; C isolates plate Y_1 from any steady voltage (which would produce shift) in the input supply, whilst resistor R (1 to 2 megohms) provides a path back to the final anode for electrons collected by Y_1 from the beam.

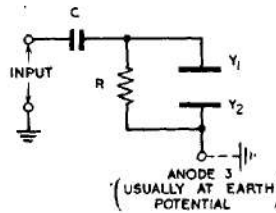

Fig. 294 - Input circuit to deflector plates.

Since in the absence of deflector plate current the resistance between a pair of deflector plates is of the order of 20 megohms, the effective load across which the input is developed is R (1 to 2 megohms).

The fact that the CRT has such a high input resistance is of importance since it means that its connection across a circuit does not usually disturb the conditions of that circuit appreciably. The inter-plate capacitance, of the order of 20 to 50 pF, is, however, shunted across the circuit supplying the plates and may cause a distinct modification of the input voltage.

If it is desired to apply both shift and work (input) voltages to one plate the circuit of Fig. 295 may be used. The resistor R is taken to the shift voltage tapping instead of directly to the anode. C_1 bypasses to anode, and so to earth, any ripple that there might be on the shift supply; the tapping on the shift slider is, therefore, at a constant potential. Thus, R is the effective load on the input source across which the work voltages are developed.

Fig. 296 shows the arrangement whereby a work and shift voltage can be applied to one deflector plate and an equal and opposite work and shift voltage can be applied to the other plate. Such an arrangement maintains the mean potential of the pair of plates at a value always equal to that of the anode, and so avoids trapezium and deflection defocusing of the trace. A similar circuit allows two distinct inputs to be applied simultaneously, when the resultant deflection will be at any instant proportional to the difference of the two input voltages.

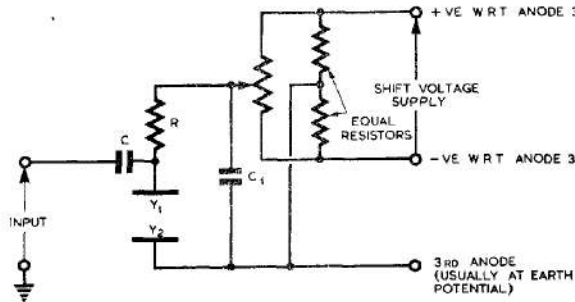

Fig. 295 - Input circuit when shift and work voltages are applied to same plate.

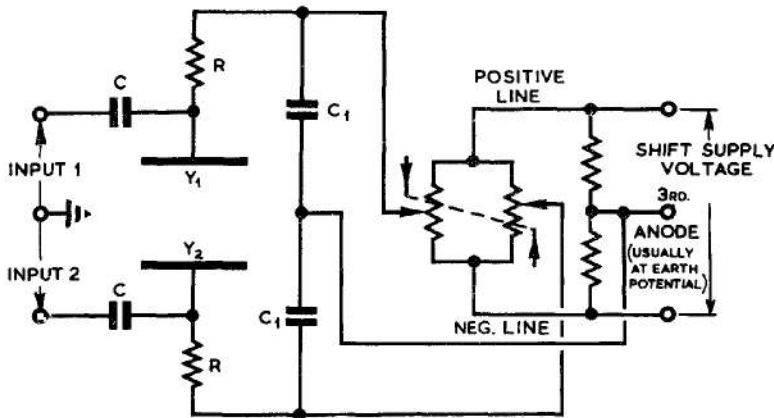

Fig. 296 - Input circuit for balanced input and deflection voltages.

31. Input Circuits to Grid and Cathode

It frequently happens that it is desired to black-out the spot of light on the screen of a CRT during some portion of its work cycle. For example; when a trace is being moved to and fro across the screen it may be necessary to eliminate the fly-back so as to prevent its obscuring the forward trace. Alternatively, it may be necessary to brighten the spot over some portion of the trace (intensity modulation). These effects can be secured by applying a pulse of voltage to the grid (or cathode). A rise of potential at the grid or a fall of potential at the cathode increases the brilliance.

Fig. 297 shows how the additional positive or negative pulses may be applied to the grid and cathode of the CRT. R_1 is the load across which the grid input voltage is developed, whilst

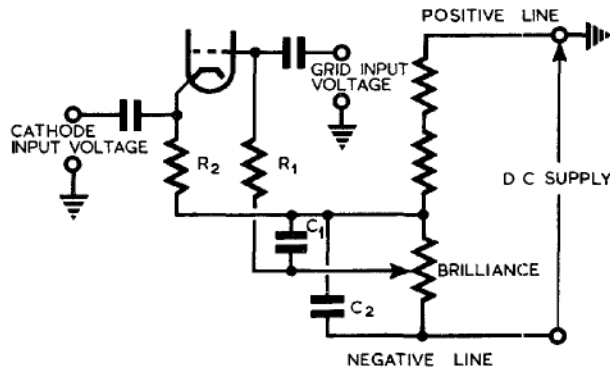

Fig. 297 - Combined grid and cathode input circuits.

R_2 is the lead across which a cathode input voltage would be applied. C_1 and C_2 bypass the ripple on the supply voltage and ensure that one end of each of the resistors R_1 and R_2 is at a steady potential. Fig. 298 shows the circuit arrangement if pulses are to be applied to the grid alone, while Fig. 299 shows the arrangement if pulses are to be applied to the cathode alone. These circuits are in common use in radar equipments. In each case the condenser C must be capable of withstanding a high voltage, since one plate is normally connected to a large negative potential (potential of grid or cathode) whilst the other plate (to which the pulses are applied) is usually at a small positive potential.

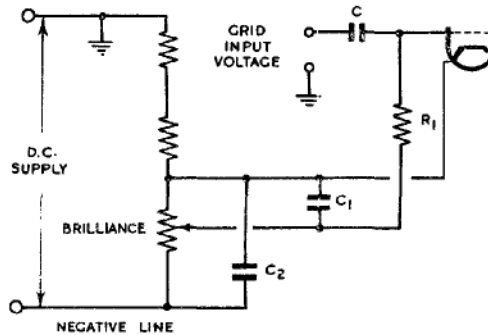

Fig. 298 - Grid input circuit.

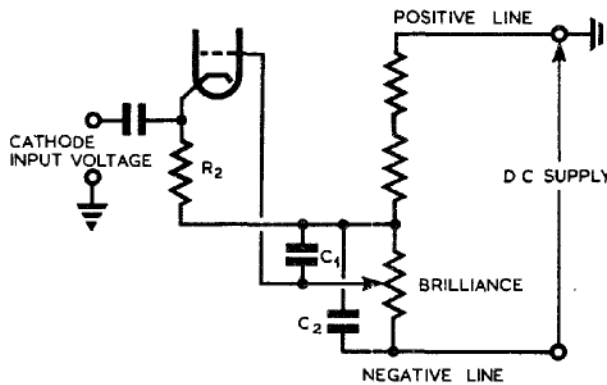

Fig. 299 - Cathode input circuit.

HARD VALVES32. Introduction

In the following sections are discussed some of the special problems which apply to the use of hard valves in circuits peculiar to radar, as distinct from conventional radio circuits. No attempt will be made to describe the more normal uses of valves, which are adequately dealt with in other works.

33. Power Valves for Radar Transmitters

In radar systems which transmit pulses of short duration, of the order of a microsecond, at intervals of about one millisecond, the problem of power conversion is somewhat different from that which arises in conventional radio transmission. The transmitting valve, whether a triode such as might be used at 50 Mc/s., or a centimetric oscillator, such as a magnetron, is required to emit high-voltage pulses which, if they were allowed to last for more than a few microseconds, would rapidly destroy the valve due to excessive anode dissipation and consequent overheating. Owing, however, to the relatively long quiescent interval between pulses, the valve is able to recover from its temporarily overworked condition. In this way power valves may be used without particularly elaborate cooling systems, at voltages far above their ordinary CW rating. Such a valve must have a very high emissivity, and therefore a large cathode, compared with that of a radio transmitting valve, to generate adequate peak currents. The anode, however, need not be unduly large, and air-cooling is usually employed. In some cases the anode takes the form of a brass block which is cooled by air pumped through cooling ducts. In others, fins in a current of cool air provide sufficiently rapid heat dissipation.

The precautions usual in high-frequency circuits must be taken in the construction of the valves. Electrode leads must be kept as short as possible and inter-electrode capacitances reduced to a minimum. Acorn and Door-Knob valves have been designed to meet these requirements, and may be employed as radar transmitting or receiving valves at frequencies up to about 600 Mc/s. Above this frequency special types of transmitting valves must be used in which the tuned circuits form an integral part of the valve itself; examples of these are given in Chap. 8 Sec. 17. The limitations of conventional valves at high frequencies are further discussed in Chap. 7 Secs. 24 and 25.

34. Suppressor-Grid Characteristics

In many radar control and generating circuits multi-electrode valves are employed under conditions not normally encountered in conventional radio practice. In particular the use of the suppressor grid of a pentode as a control electrode is common. A brief description is given below of some of the effects of varying the suppressor-grid potential.

Since the suppressor grid was originally introduced between screen grid and anode to eliminate the well-known kink in the $I_a - V_a$ characteristics of a tetrode it is to be expected that if the potential of the suppressor grid is raised substantially above that of the cathode the kink in these curves will reappear. This does, in fact, happen, and if the suppressor grid is not held at a low potential the valve acts like a tetrode. Over the region of "negative slope resistance" an increase in anode voltage causes a decrease in anode current and an increase in screen current.

If the suppressor grid is made negative with respect to cathode the anode and screen-grid currents are usually very much affected. A reduction in the suppressor-grid potential, making it more negative, increases the potential barrier between screen grid and anode, reduces the anode current and increases that of the screen. Normally the suppressor grid must be made very negative before the anode current is completely cut off. For most RF pentodes with potentials at the anode and screen grid of a few hundred volts the suppressor grid must be made from 50 - 100 volts negative to cathode before anode current is cut off. Some valves have been specially constructed with closely wound suppressor grid wires, so that cut-off of the anode current occurs for only a few volts of negative bias on the suppressor. These valves may be especially suitable for use as Gate Valves or in Transitron oscillators or relays.

In a Gate Valve signal voltages are usually applied to the control grid, whilst gating pulses are applied to the suppressor grid or some other electrode. Generally the suppressor grid is held at a negative potential, sufficient to cut off anode current. Positive-going pulses are applied, raising the suppressor-grid voltage sufficiently to allow anode current to flow (provided the control grid is above cut-off potential). Thus only those signals are effective which appear at the control grid during the intervals of the positive-going pulses at the suppressor.

In the Transitron circuits use is made of the effect of the suppressor grid on the screen current (See Chap.10, Sect.5).

Fig.300 shows characteristics of two valves CV1065 and CV1091, operating under the conditions shown in Fig. 301. In both cases the screen-grid voltage is seen to depend on that of the suppressor grid in a curious manner. Consider the curve marked ABCD in Fig. 300. From A to B the suppressor-grid voltage is below the level sufficient to cut off anode current, and there is little change in screen current as the suppressor voltage is varied over this region. At B anode current begins to flow, and for the region B to C an increase in suppressor potential increases I_a and decreases the screen current I_s , so that the screen voltage rises.

From C to D the screen current increases, as the suppressor voltage rises, probably due to secondary emission from the anode.

As indicated in the diagrams, this portion of the screen-voltage, suppressor-voltage characteristic is very pronounced for low values of anode potential only and corresponds to the kink which is introduced in the $I_a - V_a$ characteristic of the pentode, due to the positive suppressor-grid voltage. Some secondary emission also occurs from the suppressor, and if the voltage at this electrode is raised for a short interval sufficiently far above cathode potential secondary emission may follow at such a rate as to cause the suppressor grid to remain at a high potential, if the path connecting it to the cathode is not of very low resistance.

If screen and suppressor grids are connected by a condenser, as in transitron circuits, the region BC of the above curve corresponds to a region of regeneration. An increase in potential at the suppressor causes an increase in anode current and a decrease in screen current, so that the screen voltage rises. Due to the coupling condenser, the suppressor grid voltage rises still further, and the action is cumulative. Over the region CD, the action is degenerative.

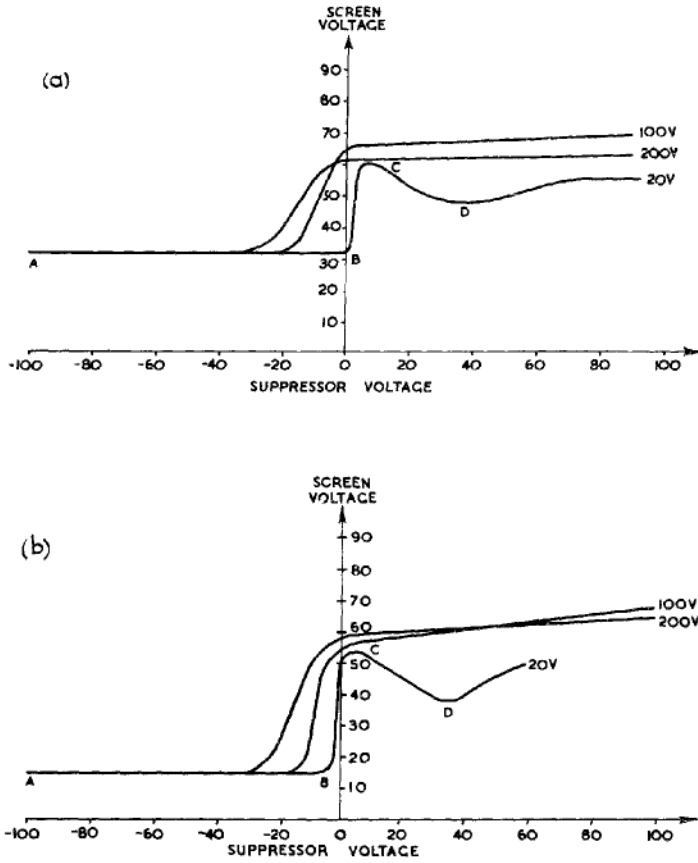

Fig. 300 - Characteristics for
(a) CV1065 (b) CV1091 for different
values of anode voltage.

Details
of circuits
which
employ this
type of
coupling
are
given in
Chap. 8
and 10.

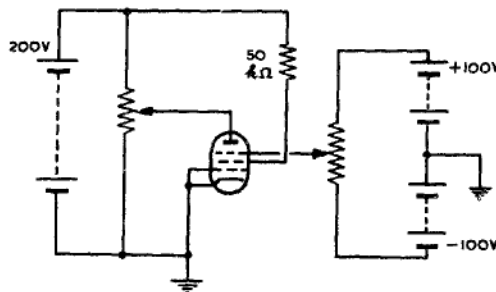

Fig. 301 - Circuit corresponding to
curves of fig. 300.

SOFT VALVES

35. Summary on the effect of gas in valves

If gas at a low pressure is present in a valve it has no appreciable effect on the characteristics so long as the electrons are moving in the valve so slowly that they cannot ionise it. If, however, the anode potential is gradually increased, and the electron velocity thereby increased also, a potential will be reached at which the gas is ionised so that some molecules are split into electrons and (relatively) heavy positive ions.

If the potential difference between anode and cathode is greater than a critical value, called the Ionisation Potential for the gas, the electrons can just acquire the requisite speed, during the intervals between collisions with gas molecules, to maintain the vapour on an ionised state.

As soon as ionisation occurs the space-charge distribution in the valve is profoundly modified. The electrons emitted by bombardment join the stream of primary electrons and travel rapidly towards the anode; the heavier, and therefore more slowly moving, positive ions travel towards the cathode where they neutralise the electron space-charge.

It will be recalled that in a hard diode valve, for small anode potentials, the presence of space charge is the only factor preventing the total emission current reaching the anode. As soon, therefore, as the positive ions neutralise the space-charge the full emission current reaches the anode, although the anode potential may be considerably below that required to produce saturation in the absence of ionisation. The effect is illustrated in the diode characteristics of Fig. 302 in which the curve a, b, c, d, represents the behaviour of a hard hot-cathode valve, and a, b, e, d, that of a similarly constructed valve containing gas at low pressure. For anode potentials less than V_s there is no ionisation and for both valves the current is space-charge limited. For potentials greater than V_s the gas in the soft valve ionises, the space charge is neutralised and the full emission current I_a flows.

Soft valves may have considerable variation in design, but may be classified under three general headings:-

- (i) Cold Cathode Diode Valves
- (ii) Hot Cathode Diode Valves
- (iii) Hot Cathode Triode Valves.

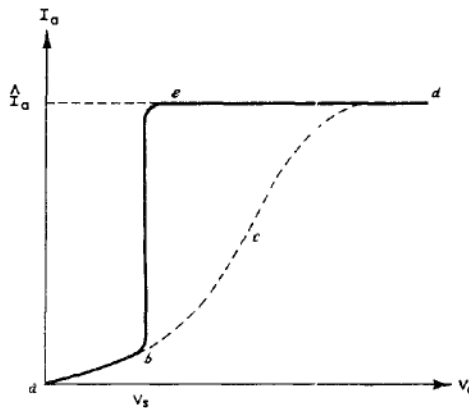

Fig. 302 - Effect of gas on diode characteristic.

Other types of soft valves such as Spark Gaps and Soft Rhumbatrons are of special application in radar systems.

36. Cold Cathode Gas Diode

In this type of valve inert gas is present at low pressure. In the normal state the molecules are electrically neutral and no current flows. As the potential difference between anode and cathode is increased a degree of polarisation of the gas molecules will be set up, and ultimately the Striking Voltage is reached at which ionisation is initiated. This process may be further complicated by extraneous irradiation, such as ultra-violet radiation, and as a result the striking voltage is not in general clearly defined.

The striking voltage, normally about 120 volts, is always greater than the ionisation potential, and corresponds to the "flash-over point" or breakdown of the gas dielectric. Once the valve has struck its subsequent behaviour is similar to that of a hot-cathode diode.

The gas will remain ionised until the current is reduced below a value called the Extinction Current. Provided the anode current is greater than this value the anode-cathode voltage remains constant at approximately the ionization potential of the gas. This is called the Extinction Voltage.

This valve has use as a HT stabilising device since, once it has struck, its anode-cathode voltage is stabilised at the value of the extinction voltage.

The tube may also be used as the discharge element in simple forms of time-base circuits, but its use in this application is limited by the relatively small separation, about 30 volts, between extinction and striking voltages, and also by the uncertainty in the value of the striking voltage noted above.

The Stabilovolt, which is discussed in Chap. 19 Sect. 10, is a development of the principle outlined above.

37. Hot Cathode Gas Diode

In general this type of valve contains mercury vapour at a pressure of about 10^{-5} mm. of mercury. A small amount of liquid mercury is present in the tube at room temperature and this is vaporised when the temperature is raised by the application of heater voltage, so that the requisite vapour pressure is produced. This valve is commonly employed for power rectification due to its large current-carrying capacity. Since in this case the onset of ionisation depends on the electron current emitted by the hot cathode the uncertainty in the value of the striking voltage is largely eliminated. The separation of striking and extinction voltages is extremely small. If an attempt is made to raise the voltage above its extinction value while the gas is ionised the cathode will be damaged by positive ion bombardment. For this reason a limiting resistor is normally included in series with the valve to ensure that the voltage across the valve does not exceed a safe value.

The performance of this valve depends very considerably on temperature since this affects the vapour pressure of the mercury and therefore the probability of collisions occurring between electrons and molecules so as to cause ionisation.

38. Hot Cathode Gas Triode

This type of valve is normally termed a Thyatron, although actually this word is a trade name for hot-cathode mercury triodes made by one manufacturer.

A grid is introduced to provide control over the striking voltage; this grid has no control over the extinction voltage. In the absence of ionisation the effect of the grid voltage on the anode current is similar to that for a hard triode valve. For a given grid voltage, negative to cathode, the anode voltage must be raised above a certain value, the cut-off value V_c , before anode current flows. This will not cause ionisation unless V_c is greater than the ionisation potential V_E . Hence, ionisation will not be initiated for a given grid voltage unless the anode voltage is raised above the greater of the two voltages, V_c and V_E . Fig. 303 shows the $I_a - V_a$ characteristic for a typical gas-filled triode at zero bias; i.e., with $V_g = 0$.

Alternatively if the anode voltage be at a value greater than V_E then there is a critical voltage for the grid below which ionisation will not be initiated. This grid control can be made exceedingly sensitive by a suitable design of the electrode assembly.

Once ionisation occurs, variation of the negative potential of the grid has little effect on the space current, since positive ions are attracted to, and surround, the grid so that the electrostatic effect of this electrode is neutralised. The grid therefore loses control until De-ionisation (Recombination) takes place, which can occur only as a result of lowering of the anode potential below the extinction value; in short, after ionisation occurs, the performance is identical with that of a hot cathode diode. The de-ionisation time (10 to 1,000 microseconds) depends on the electrode-potentials and, in general, may be shortened by the application of a negative potential to the anode; such a practice, however, may appreciably shorten the life of the valve, as positive ion bombardment ensues, with consequent spattering of anode material. For this reason the application of large negative anode voltages is usually avoided.

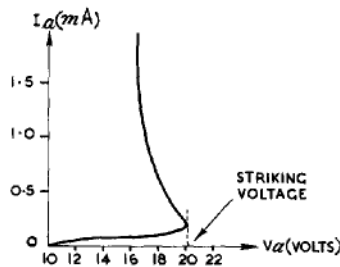

It will thus be seen that by making the grid voltage sufficiently negative a wide difference between striking and extinction voltage can easily be achieved.

Fig. 303 - Characteristic of typical hot-cathode triode with Argon gas filling, at zero bias.

As mentioned previously, the lower is the anode potential the higher the grid potential needs to be in order that ionisation may occur. The Striking Characteristic of a thyratron is shown in Fig. 304. It is seen that over a large portion of the characteristic the ratio of the increase of anode voltage needed to initiate ionisation to the corresponding change of grid voltage is almost constant. This ratio is known as the Control Ratio and is of the order of 20 to 100.

The grid loses control of the valve current once the arc has started, but its potential is important since this electrode may draw appreciable current. If the grid is at a positive potential it collects electrons and the value of this grid current rises rapidly with grid potential. If, however, the grid is at a negative potential it collects positive ions, and this reverse grid current tends to be small and nearly constant with change of grid potential (Fig. 305). Since large grid-current flow is possible for relatively low values of grid voltage it is advisable to include a limiting resistor in series with the grid so that the grid is maintained at approximately zero potential.

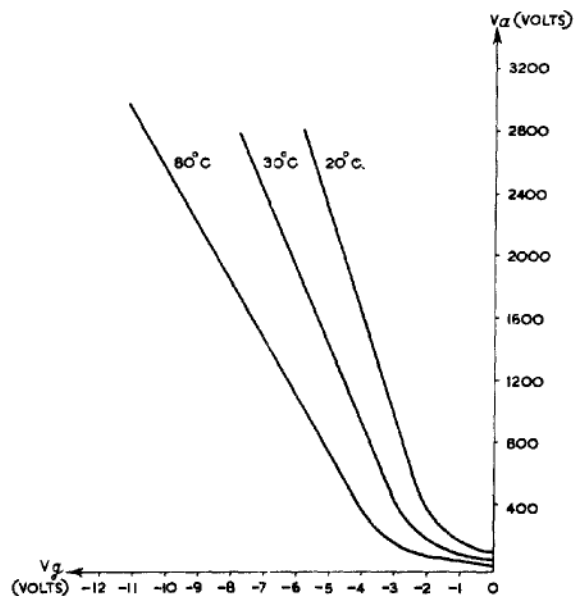

Fig. 304 - Striking characteristics of a typical mercury-filled triode for different temperatures.

Gas triodes are very easily damaged if they are allowed to pass very large currents. If the valve current is allowed to reach the value of the emission current, it means that there is no electronic space charge left at the cathode, and therefore no protection of the cathode surface from positive ion bombardment. This valve current may be limited by inserting a resistor in series with the valve.

The gas used in such triodes is either mercury vapour or one of the inert gases such as neon, argon, helium or hydrogen, or some mixture of these. In the mercury vapour valve, liquid mercury is normally present with the vapour, so that changes in temperature alter the amount of vapour present and hence the operating characteristics of the valve (Fig. 304). In valves filled with neon or one of the other gases the quantity of gas remains constant and the ionisation is therefore hardly affected by changes of temperature, within wide limits. In such valves, however, there is an absorption of gas by the electrodes which causes a change in the gas pressure, and it is this factor, in the main, which determines the working life of hydrogen filled valves.

Because of its adaptability, being usable over a wide range of striking voltages, the hot-cathode triode is employed in many types

of circuits where relatively large currents are required. For very high powers, however, the size of the valve which is necessary and the comparatively elaborate construction have resulted in such valves being superseded by spark gap or ignitrons. One of the chief disadvantages of large thyratrons is the delay involved in heating the valve to the correct temperature so that the mercury vapour pressure is at the operating value. This usually involves the use of a thermostat which incorporates a cooling, as well as a heating device, since overheating may cause erratic operation.

39. Spark Gaps

It is sometimes necessary to arrange a circuit so that a switch is closed when the potential across its terminals reaches a certain high value. This process is conveniently carried out by putting a spark gap between the terminals. As in the case of the cold cathode diode, when the potential reaches the value of the striking voltage the gap conducts, and while it is conducting its resistance is very small. When the potential is removed the spark is extinguished after a period of de-ionisation and a high potential can again be built up before the gap once more conducts. This principle is used in the obsolescent spark telegraphy.

Spark gaps are used in radar for switching (a) in high-power modulators which employ a pulse-forming network and (b) in common T/R systems (where the same aerial is used for both transmission and reception).

In modulating circuits it is usually required that the spark should occur at precisely regular intervals. It is therefore more satisfactory not to control the operation by allowing the voltage across the main electrodes to reach its relatively variable striking voltage, but to initiate the ionisation by the use of a control electrode, whose function is similar to that of the grid of a thyatron. The spark between the main electrodes is struck by the application of pulses of high voltage, but not necessarily of high power, between a third electrode and one of the two main electrodes. Spark gaps which operate on this principle are known as Triggered Spark Gaps, and the third electrode is termed the Trigger Electrode. The triggering pulses, since they need not be of high power, can be readily developed by circuits using normal hard valves.

Alternatively, the distance between the main electrodes can be varied in a cyclical manner so that they approach each other sufficiently closely for the spark to strike at the required instants. Rotary Spark Gaps operate on this principle.

The chief advantages of spark gaps compared with hot cathode valves of comparable dimensions are their robustness and high power-handling capacity. The principal disadvantage of spark gaps is their inflexibility, since for a gap of given dimensions the striking voltage cannot be adjusted. In such a case the design of the modulator is largely determined by the characteristics of the spark gap used.

40. The Triggered Spark Gap

This type of spark gap consists essentially of three electrodes; in its commonest form, the two main electrodes take the form of hemispherical caps and the trigger electrode is a wire the end of which protrudes through an aperture in one of the main electrodes. A common construction is illustrated in Fig. 306. Here the main electrode A is connected to a metal cylinder B surrounding the trigger electrode T and separated from it by glass insulation G.

In normal use the spacing between A and C should be such that a spark does not strike between these electrodes, even when the maximum potential difference between them is reached, unless ionisation is initiated by the application of a triggering voltage between A and T. The possibility that sparking may occur between A and C before it is required is reduced by shaping A and C in such a manner that high field concentrations are avoided at the surface of these electrodes. A spark between A and C is extinguished when the voltage developed between these two electrodes falls to a low level, the value of which is determined by the ionisation potential of the gas in the gap.

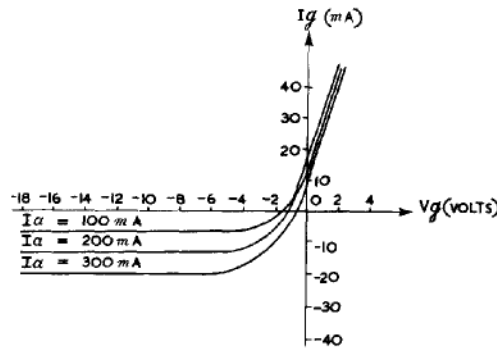

Fig. 305 - Grid current characteristics of a typical thyatron.

The manner in which the triggering voltage has effect in initiating the striking of the spark between A and C is not always clear, but two distinct modes of operation are possible, depending to some extent on the design of the spark gap and to a larger extent on the relative polarities of the applied potentials. It is usual for the electrode A to be earthed, since this permits the circuit producing the trigger pulse to operate near earth potential. The two possible modes of operation are :-

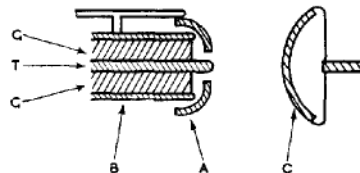

Fig. 306 - Electrode assembly of triggered spark gap (not to scale).

- (i) The triggering voltage applied between A and T causes a breakdown of the small gap between these electrodes and the light emitted by the resultant discharge causes ionisation of the molecules in the main gap AC (possibly there is also some drift of ions into the main gap) and so initiates the main spark. In general this form of discharge is more likely to occur if the potential applied to the trigger electrode is of the same polarity as that of electrode C.
- (ii) If the potential applied to the triggering electrode is of opposite polarity to that of the electrode C, the potential difference between these electrodes is the sum of the magnitudes of their potentials and since in addition there is a high concentration of field and possibly a corona discharge at the point of T, a spark

is likely to strike between T and C. As soon as this occurs a large current flows between T and C causing the potential of T to reach much the same value as that of C, the actual potential acquired by T depending on the relative impedances of the input circuit to T and the output circuit from C. The potential difference between T and A is then normally large enough to break down the gap between these two electrodes. The discharge path between A and C is then completed. It is assumed here that the magnitude of the initial triggering voltage is not large enough to give rise to a discharge between T and A.

The mode of operation (ii) has the advantage that the triggering voltage necessary to initiate the main spark can be smaller in value than that required in case (i). The position of the insulator G, separating T and A has some bearing on the value of the voltage required to trigger spark gaps operated by the mechanism (i). If the insulator is fairly near the front of the electrode A it considerably reduces the necessary triggering voltage, probably due to tracking of the discharge along its surface. Again, for this type of operation, in order to produce efficient irradiation of the main gap by the triggering discharge it is desirable that this takes place between the trigger electrode and the front edge of A. Consequently, the front edge of A should be made sharp.

The action of triggering a three electrode spark gap normally results in jitter, i.e., a random fluctuation in time interval, between the application of a triggering pulse and the instant at which spark discharge occurs. This jitter often may result from random variations in conditions of ionisation in the gap, resulting in a change of the value of impressed voltage necessary to cause the gap to strike. Therefore, since a trigger voltage must take a finite time to build up, jitter will result. Jitter due to this cause may thus be reduced if the triggering voltage can be arranged to build up to the critical value very rapidly, and this can most easily be achieved by providing a triggering voltage much larger than the minimum critical value needed to fire the gap. On the other hand it is clearly desirable from the stand-point of the design of the trigger-producing circuit that the trigger voltage to be produced should be no greater than necessary. In practice, a certain amount of residual ionisation remains between successive ardings and it is necessary to have a higher triggering voltage to break-down the main gap at first than subsequently. If the triggering voltage is made just large enough to trigger off the first spark in the main gap, it is sufficiently above the minimum voltage necessary for triggering subsequent sparks to ensure that only a small amount of jitter occurs.

Since there is asymmetry of the electrodes of the spark gap there is reason to expect that the amount of jitter depends on which of the two main electrodes is used as the anode. Experience shows that in most radar equipments the more reliable operation of the spark gap, from the point of view of accurate timing, occurs if the electrodes A and C serve respectively as anode and cathode of the main discharge.

There is a tendency for the main gap to break down, at voltages lower than expected from the separation of the main electrodes, before the trigger voltage is applied. This effect is probably due to excess of ionisation remaining from a previous spark, and its incidence limits the recurrence frequency. The possibility of this premature sparking is much less if the value or duration of the spark current is reduced, and if it is possible to remove the residual

products of the previous spark by, say, blowing air into the gap. This of course precludes the possibility of enclosing the spark-gap structure. De-ionisation time is also affected by the type of gas in which the spark is produced.

Triggered spark gaps operate very well in air at atmospheric pressure provided they are not enclosed. If they are enclosed, their life may be fairly short. This is probably due to the production of nitrogen peroxide by the discharge. The presence of this gas in the gap increases its sparking potential and makes it inoperative at its previous potential ratings.

Although it is generally not necessary for a spark gap to be enclosed in an airtight envelope if it is always to be used on the ground, for airborne use such an envelope (usually glass) is desirable, due to the variation of pressure with height.

It appears necessary, in order that the de-ionisation time be sufficiently rapid, for the gas in which the spark is struck to contain a certain amount of oxygen, which has the property of promoting rapid de-ionisation. Various mixtures of gases are suitable, two of which are: one, a mixture containing 90% nitrogen and 10% oxygen at atmospheric pressure, and the other a mixture of 97% argon and 3% oxygen at three atmospheres pressure.

The life of an enclosed gap depends largely on the rate at which the oxygen in the gap is used up either by oxidation of the electrodes or by combination with the other gases present in the case of the air-filled gap. Also the electrodes are liable to wear both by oxidation and by sputtering in the spark. In order to reduce the wear they are usually made of molybdenum or tungsten.

41. The Rotary Spark Gap

In this form of spark gap the electrodes are generally fixed, and a metallic arm is rotated between them at a uniform speed by means of an electric motor. The axis of rotation of the moving arm cuts the line joining the electrodes mid-way between them, so that in one position the two ends of this arm just clear the respective electrodes simultaneously (Fig. 307). When the rotating arm reaches some such position as that shown in the figure then a spark

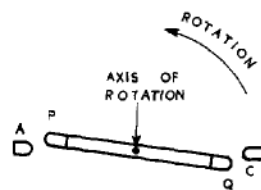

Fig. 307 - Electrode assembly of rotary spark gap.

strikes between A and P and between C and Q, forming a conducting path from A to C; i.e., the switch whose terminals are A and C is closed. The spark is extinguished when the voltage driving current through the switch falls to a low value, and not, in general, because the movement of the metallic arm has caused an increase in the spacings AP and CQ. In normal operation the required duration of the spark is of the order of 1 microsecond, in which time the metallic arm does not move appreciably.

The recurrence frequency of the spark is twice the frequency of rotation if a single arm is used. However, this frequency is increased if there is more than one arm. Thus, with a rotating spark gap of the form shown in Fig. 308 the recurrence frequency of the

spark is four times the frequency of rotation of the arms, so that if the motor driving the rotating electrode has a rating of 6000 r.p.m., the spark recurrence frequency is 400 per second. Recurrence rates as high as 2500 per second have been obtained.

If there is more than one pair of fixed electrodes arranged round the circumference of a circle, and more than one arm, it is possible to provide a number of spark-gap switches whose times of closing are synchronised. An arrangement such as this is required for the Marx circuit, (Chap. 14 Sec. 38).

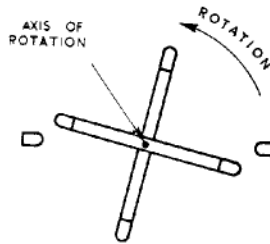

Fig. 308 - Double arm rotary spark gap.

The closeness with which two electrodes have to approach before a spark strikes, if there is a potential difference between them, is rather erratic, and varies slightly in this form of a spark gap for successive strikings of the spark. Consequently, there is a slight variation in the time interval between successive sparks. This jitter is smaller the larger is the radius from the axis of rotation to the point at which the spark is struck, since then the circumference covered by the moving arm between successive strikings of the spark is large compared with the variations in the sparking distance. Furthermore, if the repetition rate of the spark is increased by increasing the number of arms mounted on the same shaft, the length of the moving electrode must be proportionately increased if the relative amount of jitter is not to increase.

Owing to the difficulty of reducing jitter beyond a certain point with reasonable dimensions between the fixed electrodes, the applications in which a rotary spark gap can be used are rather more restricted than those in which a triggered spark gap can operate. For example, since the time of discharge of the spark is liable to some variation as the rotating arms approach the fixed electrodes, it cannot readily be co-ordinated with an independent source of timing. In fact when a rotary spark gap is used in radar equipment the timing of the spark itself must be used as the basis of synchronisation of the whole system if accurate measurement of time-intervals is required. However, the random nature of the timing of a rotary spark gap in a radar equipment does decrease the chance of periodic external interfering signals being "locked" to the transmitted pulse and so giving the appearance of an Eche (re-radiated signal).

When the spark is struck the current flowing between the electrodes is usually very heavy (50 amperes or more), and consequently the electrodes of the spark gap tend to wear. To minimise this it is usual for the ends of the electrodes to be made of molybdenum. The life of a rotary spark gap is determined almost entirely by the wear of the molybdenum electrodes. This wear is governed chiefly by the value and total duration of the current so that the life of the device is roughly inversely proportional to the peak current, duration and repetition rate of the sparks.

The factor which ultimately limits the maximum recurrence frequency at which a spark gap can operate is the time taken for the

gases to de-ionise. However, in a rotary spark gap the sparks are unlikely to be maintained except during the short interval when the rotating arm is close to the stationary electrodes. Besides, the spark normally takes place in air and is not enclosed, so that the motion of the moving arm creates a draught which tends to clear ions away from the fixed electrodes after a discharge has ceased in readiness for the next spark. For these reasons the spark gap can be operated at a high spark recurrence frequency (e.g. 2,500 per second).

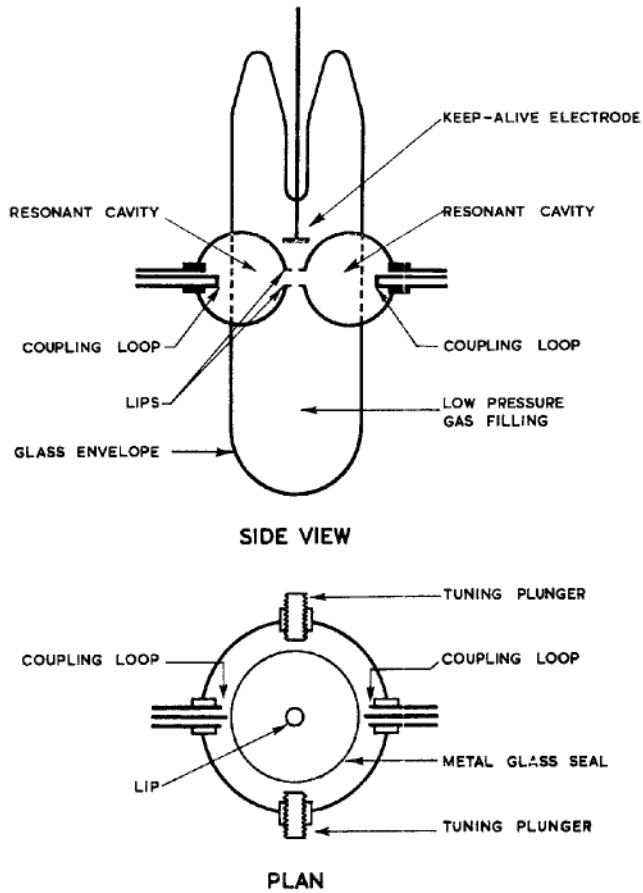

Fig. 309 - T/R Switch

42. The T/R Switch

In many radar equipments one aerial system is used for both transmission and reception of signals. This arrangement involves the use of a switch which is so arranged that during transmission of RF pulses the transmitted power is prevented from reaching the receiver, whereas during reception the received power is allowed to pass freely to the receiver. If the transmitted power were permitted to reach the receiver, designed to deal with extremely low level signals, (not greater than $1/10$ watt), it would in general damage the receiver, or at least render it inoperative for the reception of signals.

Transmitted peak powers are normally considerably greater than $1/10$ watt (they may be 50 kW. or more) so that the switch between the transmitter and receiver must operate so as to prevent the major portion of the transmitted peak power from reaching the receiver. Furthermore, the switch must be capable of passing received signals, which are in general of considerably less power level than $1/10$ watt, and should be able to do so within a fraction of a microsecond after the transmitter has ceased to operate.

The construction of a typical T/R switch is shown in Fig. 309. It consists essentially of a rhumbatron, (cavity resonator, Chap. 5 Sec. 25) the lips of which are enclosed in a glass envelope containing gas at low pressure. The normal filling of the envelope is water vapour at a pressure of 6 mm. of mercury. Coupling of RF power in and out of the resonator may be made by means of small loops, which are fed from coaxial lines, or by wave-guide feed, while the tuning of the resonator may be accomplished by means of screw plungers.

If the switch is inserted in a coaxial line fed by a RF voltage generator, the following behaviour is observed. For low RF powers, less than $1/10$ watt, if the resonator is tuned to the appropriate frequency and the coupling loops correctly adjusted the switch acts almost as a one-to-one transformer, and the transmission is nearly perfect; (Fig. 310). In practice there is a small loss of power known as reception or low-level loss of the order of 0.5 db. in passing through the switch. If the input voltage is increased, the RF voltage developed across the lips of the resonator becomes large

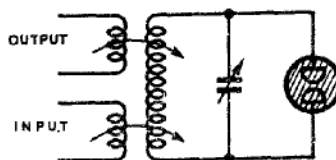

Fig. 310 - Analogue of T/R switch circuit

enough ultimately to initiate glow discharge. Once ionisation has taken place this voltage remains approximately constant at a low value, being analogous to the extinction voltage of simple gas valves. The power transmitted through the device is then a function of the running voltage, and since this voltage is effectively constant, the power transmitted through the switch is small and practically independent of the input voltage. The glow discharge can be considered as placing a low shunting resistance directly across the cavity. (Fig. 310).

The protection afforded to the receiver by the switch during the period of operation of the transmitter of a radar equipment is determined by the running voltage of the glow discharge and the break-down time of the gap. The running voltage is closely related to the pressure of the water vapour used in filling the switch, whilst the breakdown time, besides being dependent on conditions of operation (see below), is also related to the effective Q (normally about 300), of the resonator. The Q of the resonator determines the rate of rise of voltage across the lips of the resonator. The break down time should be as short as possible since, until a glow discharge is formed, transmission through the switch is unimpaired. In general the protection improves as the effective Q is increased or as the water vapour pressure is lowered from 15 to 2 mm. of mercury; (see Fig. 311).

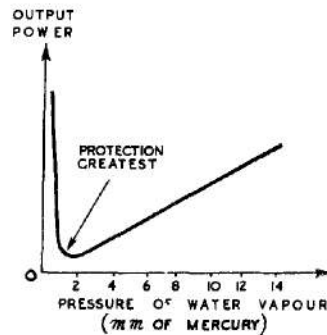

Fig. 311 - Effect on T/R switch of variation of gas pressure.

The recovery time of the switch is also found to be dependent on the pressure of the water vapour filling and on the effective Q of the resonator. In general, the recovery time becomes worse as the effective Q is increased or as the water vapour pressure is reduced from 15 to 2 mm. of mercury.

As the effective Q is increased the resonator tuning becomes more critical.

A water vapour filling is found to give a short recovery time (Fig. 312). Other gases which are suitable from this point of view are found to be unstable when subjected to RF discharge; i.e., there is a change in performance of the switch with time. When water vapour is used it may be necessary to provide heating for the switch to prevent the temperature of the water vapour from falling to too low a value (below 0°C).

The normal gas filling for a switch having a resonator with an effective Q of 300 and used in connection, say, with power of frequency about 3000 Mc/s., is water vapour at a pressure of 6 mm. of mercury. This arrangement is regarded as a reasonable compromise between protection, recovery time and criticalness of tuning adjustment. It has already been stated that the protection offered by the switch depends on the break-down time of its gap. Provided ions are already present between the lips of the switch this break-down time is very small and the protection is good.

The T/R switch, as considered so far, functions well for repetition frequencies from about 500 per second upwards, but does not protect the receiver at the time when the transmitter is first switched on. In other words, once operation has started ions persist in the space between the lips of the resonator during the intervals between transmitter pulses, provided these intervals are not longer than about 2000 microsecs; but at the start of operation there are few if any ions present.

In order to provide the necessary ions at the start of operation, it is usual to run a steady current discharge between an auxiliary electrode (Starter or Keep-Alive Electrode) and the wall of the resonator. The current of this priming discharge is normally about 1 to 2 mA. and operates at a running voltage of about 500 volts between the auxiliary electrode and the resonator. This priming discharge must of course be struck before the transmitter is switched on. There is no disadvantage if the priming discharge is left operating continuously while the radar equipment is in use, since the presence of ions in the gap does not have any appreciable effect on the transmission of received signals (of power less than 1/10 watt) through the switch.

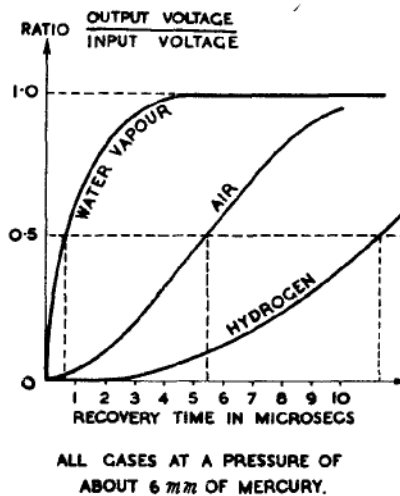

Fig. 312 - Comparison of recovering time for various gases.

SPECIAL RESISTORS

43. General

The resistors used in most electrical circuits are made of conducting materials which conform more or less faithfully to Ohm's law. In some instances, particularly at high frequencies, the self-inductance and self-capacitance of a resistor are not negligible, and must be allowed for as indicated in the equivalent circuit of Fig.313.

There are, however, other substances for which the departure from simple proportion between voltage and current (DC) is very marked. Such substances may be particularly useful for special applications. The use of copper-oxide or "cat's whisker and crystal" rectifiers is well known and needs no description here. In both cases the surface junction of metal with non-metal introduces the non-linearity which makes the combination useful in rectifying or frequency-changing circuits. Electrons leave the metal more readily than the non-metal, so that the forward and reverse resistances have widely different values.

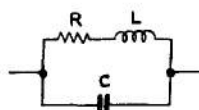

Fig. 313 - Equivalent circuit of a practical ohmic resistor at very high frequencies.

Recently various homogeneous materials have been developed which show marked non-linearity in their voltage-current characteristics without the discontinuity associated with the former combinations. The resistance decreases with an increase in current due to the unusual behaviour of the conduction electrons in the atomic structure. In addition, the negative temperature coefficients commonly associated with quasi-conductors may have a marked effect on the resistance-current characteristic, since an increase in current raises the temperature and so reduces the resistance.

In the case of Thermistors, described in Sect.45, this leads to an actual fall in voltage as the current rises, so that beyond a certain point the material exhibits the property of negative resistance.

44. Metrosil

This is the trade name of a quasi-conducting material originally developed as a lightning arrester and now widely used as a protective device in power supply circuits. The V-I static characteristic for Metrosil is shown in Fig. 314. The curve follows a power law $V \propto I^\beta$, so that the R-I curve also follows a power law. The particular value of β for a given Metrosil depends on the constitution of the material used. By suitable manufacturing methods β can be given any value between 0.2 and 0.4.

The constant of proportionality is given by the equation :-

$$V = R_1 I^\beta$$

and a Metrosil element can be made to give any required value of R_1 . This

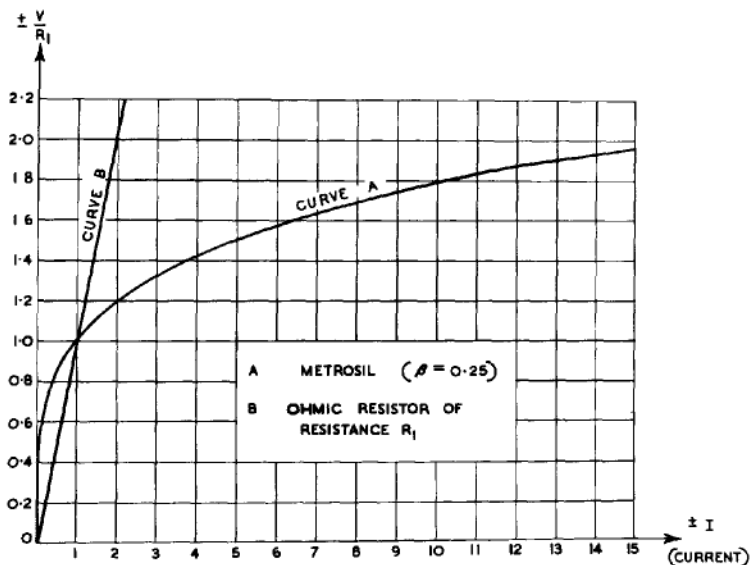

Fig. 314 - V-I characteristics, (a) **Metrosil:**
 ($\beta = 0.25$) (b) ohmic resistor of resistance R_1 .

depends, as in any other resistor, on the shape and size of the element. If R is the resistance of the element for a voltage V and a current I , then since $V = RI$ it follows that

$$R = R_1 I^{(\beta-1)},$$

and by substitution, we obtain

$$R = \frac{R_1^{1/\beta}}{V \left(\frac{1}{\beta} - 1 \right)}.$$

R_1 is the resistance presented by the **Metrosil** element to a current of one amp.

Fig. 315 represents the resistance-voltage characteristic for a one-ohm **Metrosil** element with $\beta = 0.25$. For any other value of R_1 (but the same β) the coordinates of Fig. 315 should be multiplied by R_1 . Thus, a 100 ohm **Metrosil** element would have a resistance of 100 ohms for an applied potential difference of 100 V., but only 12.5 ohms if the applied voltage were increased to 200V.

The response of **Metrosil** to alternating voltages is instantaneous so that the static characteristics are usable for AC as well as for DC. If a sinusoidal voltage is applied to **Metrosil** the resulting current is very much distorted, and the harmonic content must be taken into consideration when calculating the RMS value of the current. The RMS value of the current (I_{RMS}) is obtained by multiplying by a factor k_I the current

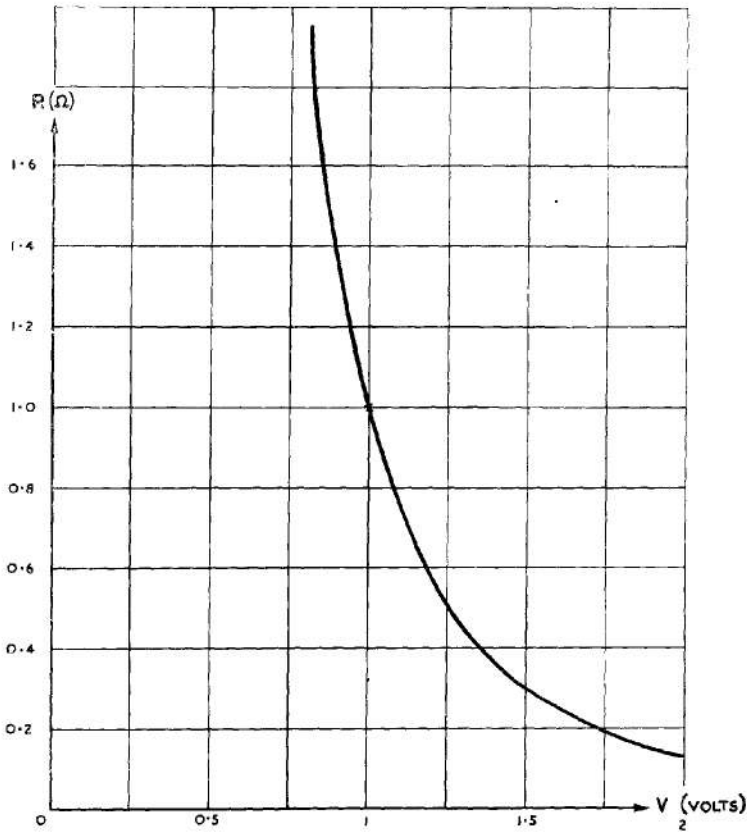

Fig. 315 - Resistance voltage characteristic for a one-ohm Metrosil element with $\beta = 0.25$.

which would flow in response to a constant voltage equal to the RMS value of the applied voltage. The variation of k_I with β is shown in Fig. 316.

The power dissipated for a sinusoidal applied voltage is given by

$$P = k_P V_{RMS} I_{RMS}$$

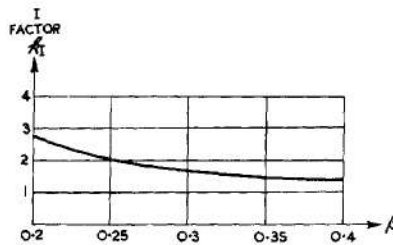

Fig. 316 - Variation of k_I with β .

where k_p depends solely on β and varies as shown in Fig. 317. (k_p is the Power Factor for Metrosil, if this term is used in its general sense).

A Metrosil element usually takes the form of a ceramic compound moulded into a disc or ring. Dampness can be excluded by impregnation or by immersion in oil. Heat has little effect, the compound being stable and mechanically strong up to red heat. The power rating depends to a large extent on the mounting. With free air circulation it is generally taken to be 1 watt/square in. of surface.

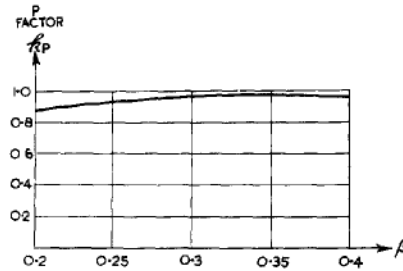

Fig. 317 - Variation of k_p with β .

When short duration overloads are to be withstood, the energy can be calculated from the approximate equation. (Energy in watt-secs) = $712 \times$ (Weight in k_g) \times (Admissible temperature rise in $^{\circ}C$).

It is found that with a rise of temperature from T_0 to T_1 $^{\circ}C$. R_1 changes approximately according to the equation,

$$(R_1)_{T_1} = (R_1)_{T_0} [1 - 0.0018 (T_1 - T_0)].$$

Various applications of Metrosil are as follows :-

When used as a voltage limiter :-

- (i) Lightning arrester.
- (ii) Safety device to suppress transient surges in inductive circuits.
- (iii) Field discharge resistors.
- (iv) Protection of contactor coils.

When used as a variable resistor :-

- (v) Overload protection.
- (vi) Voltage regulation.
- (vii) Production of harmonics.
- (viii) Pulse shaping.
- (ix) Bridged - contact switching.

45. Thermistors

Thermistors, or thermally sensitive resistors, are devices made of materials which have a high negative temperature coefficient of resistance. The resistance elements are made from a mixture of certain metallic oxides which are all semi-conductors, one of the most frequently used being uranium dioxide, which has a sensitivity of 5×10^4 ohm-cm. at 0°C , decreasing to 2.8×10^3 ohm-cm. at 100°C . Fig. 318 shows the relevant electrical properties of two commonly used thermistor materials, uranium dioxide and nickel manganese oxide, with the corresponding curve for platinum added for comparison.

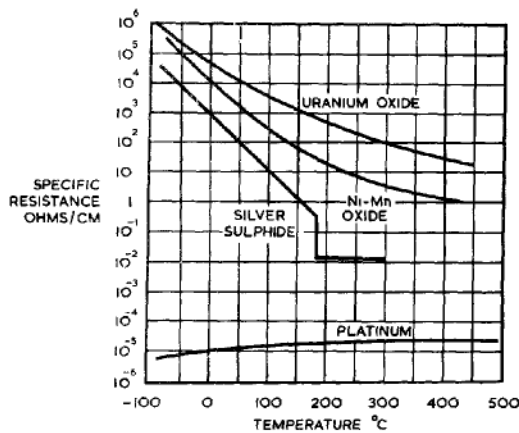

Fig. 318 - Resistance temperature characteristics of thermistor materials, with curve of platinum for comparison.

During manufacture the material is fired at a high temperature and is, therefore, not affected by subsequent heating to about 500°C .

The resistance material may be formed, from heated compressed powders, into small bead type elements, tubes, rods, discs or washers of various sizes to cover a wide range of resistances and power handling capacities. The heating of the element may be achieved by passing current through the resistance material itself (directly heated type), or by an independent heater insulated electrically from the element (indirectly heated type) or by placing the element in a heated enclosure and permitting the resistance to be governed mainly by the ambient temperature.

Some typical thermistors are illustrated in Fig. 319.

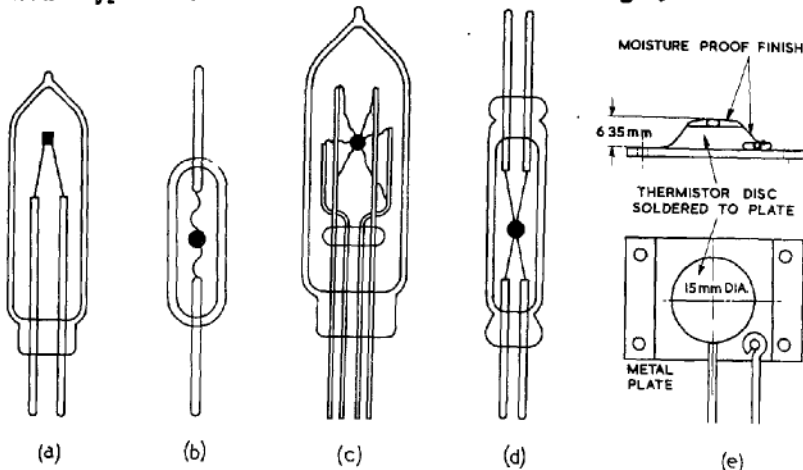
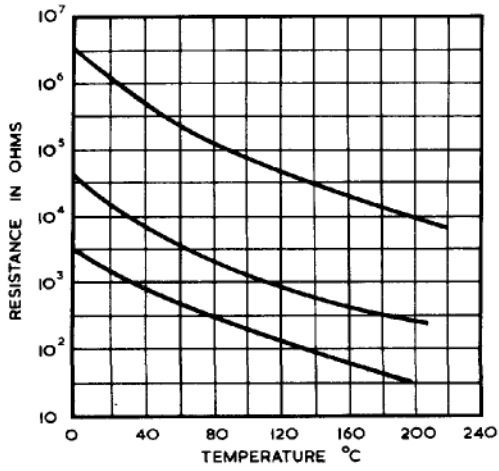

Fig. 319 - (a) (b) Directly-heated thermistors
 (c) (d) Indirectly heated thermistors
 (e) Disc thermistor

Physical Properties of Thermistors

There are three main types of characteristic curves used to specify thermistor performance: the resistance/temperature curves, the resistance/power curves, and voltage/current curves. Examples of these are shown in Fig. 320.



(a) Resistance/Temperature characteristic of three thermistors.

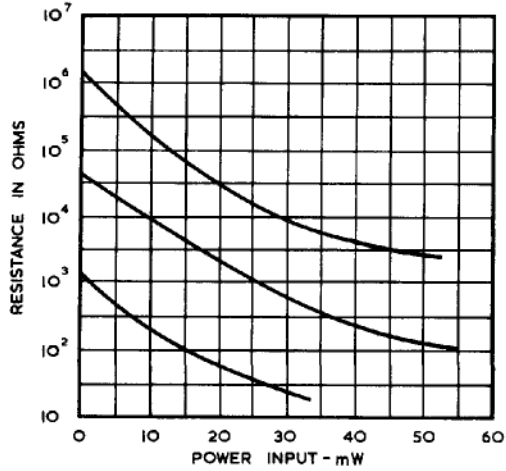

(b) Resistance/Power Input characteristic

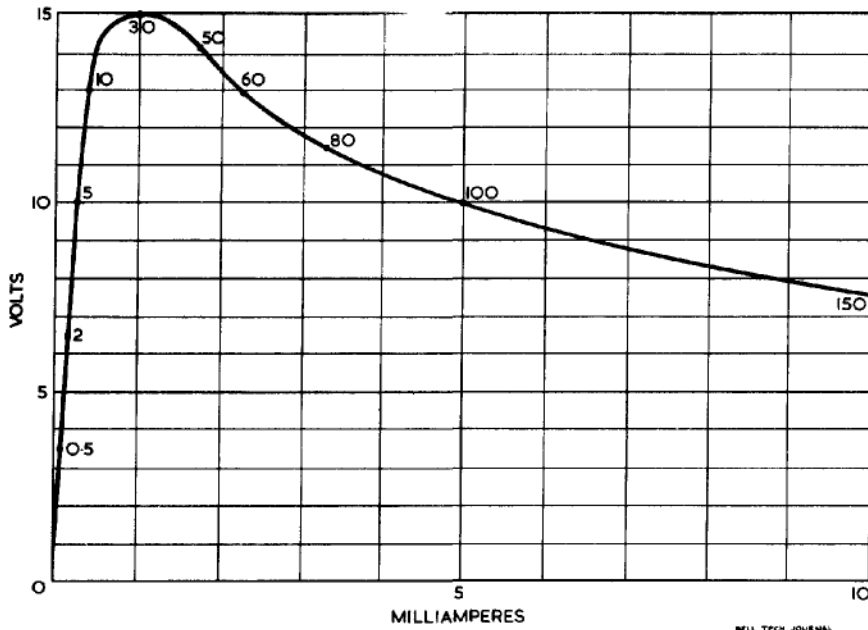

(c) Static Voltage/Current characteristic for typical thermistor (The numbers on the curve denote rise in temperature (C) above ambient)

Fig. 320 - Thermistor Characteristics

It will be noted from Fig. 320 (c) that as the current through the thermistor is increased, the potential difference rises rapidly and soon attains a maximum value. Thereafter there is a rapid drop in the potential with further increase in current. Subsequently the potential decreases very slowly and may under suitable conditions remain constant over a fairly wide range of current. The negative slope resistance property permits a wide range of applications.

In Fig. 320 (c) each time the current is changed, sufficient time is allowed for the potential to attain a new steady value. Owing to its thermal capacity the change of resistance lags behind sudden changes in applied heating power. The thermal time constant of average thermistors lies between 0.5 and 4 seconds.

Application of Thermistors

(a) Their resistance temperature characteristics make thermistors very suitable for

(i) Temperature Measurement where the large value of temperature coefficient of resistance, 5 to 10 times that of platinum, permits a higher order of sensitivity to be attained in conventional bridge or other resistance thermometry systems. The maximum operating temperature is limited to 500°C.

(ii) Temperature Control Systems

(iii) Compensators to correct for changes of resistance in electrical elements, having positive temperature coefficients of resistance, caused by ambient temperature variations.

(b) The voltage - current characteristics make thermistors very suitable for

(i) Low Power Measurement In this application the thermistor is designed to act as a power absorbing terminating resistance in the transmission line, which may be of the open wire, coaxial or wave-guide type and to form one arm of a Wheatstone Bridge circuit. The application of the power to be measured decreases the thermistor resistance and the bridge is disturbed from the initially adjusted state of balance. From the bridge meter reading or the resistance adjustment required to restore the balance the incident power may be calculated. Methods of mounting have been designed to minimise the reflection of energy from the termination and assure accurate measurement of the power over broad bands in the frequency spectrum.

The particular advantages of thermistors for this purpose are that they can be made small in size, have a small electrical capacity, can be severely overloaded without change in calibration, and can easily be calibrated with D.C. or low frequency power.

Powers from 1 microwatt to several hundred milliwatts may be measured by this technique; the lower limit is set by the sensitivity of the Galvanometer and the complexity of precautions taken, powers above 1 milliwatt being measurable with comparative simplicity. The uncertainty in measurement by present thermistor techniques of powers of approximately 1 milliwatt is less than $\frac{1}{2}$ db at 200 Mc/s, about 1 db at 3000 Mc/s and about 3 db at 10,000 Mc/s.

When power measuring test sets are intended for use with wide ambient temperature variations, temperature compensation of the thermistor is essential. This may be accomplished by the introduction of two other thermistors into the bridge circuit or by the combination of two or more thermistors with different temperature characteristics.

- (ii) Oscillator Automatic Amplitude Control.
- (iii) Amplifier Automatic Gain Control.
- (iv) Regulators, Limiters, Surge suppressors, etc.

Dynamic characteristics.

If a thermistor is biased at a point on the negative slope portion of the steady-state voltage-current characteristic, and if a small alternating voltage is then superimposed on the direct voltage, a small alternating current will flow. If the thermistor has a small time constant, τ , and if the applied frequency is low enough, the alternating voltage-current characteristic will follow the steady state curve and v/i will be negative. As the frequency increases, $1/f$ becomes smaller compared with τ and an increasing phase lag between current and applied voltage develops. This is illustrated in Fig. 321. A portion of the static curve (a) holds for direct currents. As the frequency rises the graph assumes the form (b). When the phase delay reaches 90° at a frequency f_c , say, the impedance is a pure reactance.

(c) Further increases in frequency are accompanied by a disappearance of the negative resistance property (d) and ultimately the thermistor behaves like an ordinary ohmic resistor (e) when the current and voltage are in phase.

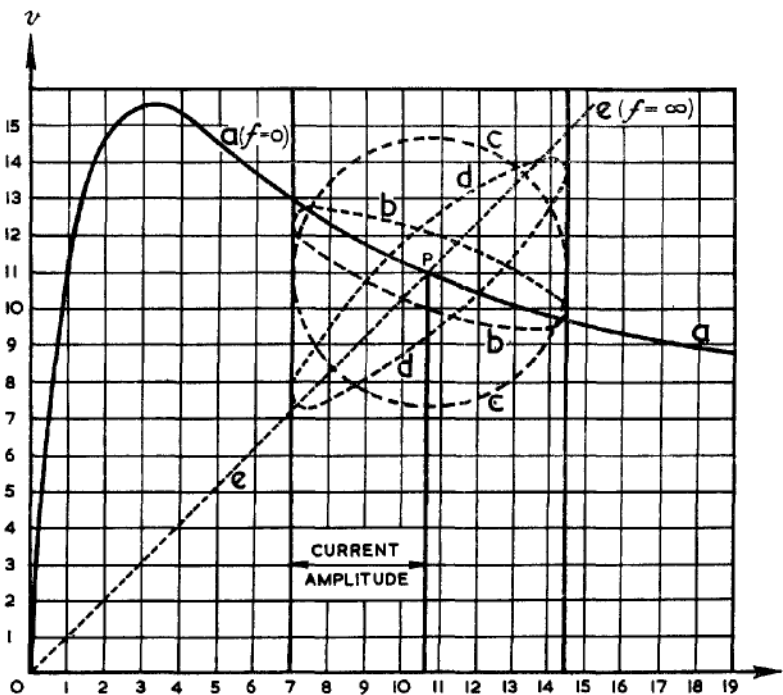

Fig. 321 - Static characteristic (full) and dynamic characteristic (dotted) of thermistor for different frequencies.

The critical frequency is given approximately by $f_c = 1/2\tau$. Thus the inherent thermal capacity of the thermistor limits the frequency range over which the negative incremental resistance properties may be utilised in oscillators, modulators, amplifiers, etc. Thermistors have been designed capable of oscillating at frequencies up to about 5 Kc/s but they cannot yet be manufactured with sufficient reproducibility and constancy to be useful outside the laboratory.

This Page Intentionally Blank

This file was downloaded
from the RTFM Library.
Link: www.scottbouch.com/rtfm

Please see site for usage terms,
and more aircraft documents.

