

## Chapter 22

## PRESSURE JERKIN Mk. 4

## LIST OF CONTENTS

	Para.		Para.
<i>Introduction</i> ....	1	◀ <i>Removal and charging of inflation mechanism—</i> ....	26
<b>Description</b> ....	3	<i>Testing of stole</i> ....	28
<i>Oxygen supply</i> ....	6	<i>Oral inflation valve renewal</i> ....	30
<i>Stole</i> ....	9	<i>CO<sub>2</sub> cylinder life</i> ....	31
<i>CO<sub>2</sub> cylinder</i> ....	10	<i>Other limitations</i> ....	32
<i>Oral inflation valve</i> ....	12	<b>Assembling</b>	
<i>Lifting beackets and life line</i> ....	14	<i>Inserting the stole</i> ....	34
<i>S.A.R.A.H. equipment</i> ....	16	<i>Fitting the CO<sub>2</sub> cylinder and operating head</i> ....	35
<i>Heliograph and emergency code</i> ....	19	<i>Stowing the S.A.R.A.H. equipment</i> ....	36
<i>Whistle</i> ....	20	<i>Stowing the lamp and sea-activated battery</i> ....	37
<i>Lamp and sea-activated battery</i> ....	21	<i>Fitting the life line and toggle</i> ....	39
<i>Personal survival pack attachment</i> ....	23	<i>Stowing the whistle</i> ....	40
<b>Servicing</b> ....	24	<i>Stowing the heliograph and emergency code</i> ....	41
<i>After immersion in salt water</i> ....	25		

## LIST OF ILLUSTRATIONS

	Fig.		Fig.
<i>Pressure jerkin Mk. 4</i> ....	1	<i>Connecting the beacon to the battery switch pin: third stage</i> ....	8
<i>Jerkin details (1)</i> ....	2	<i>Connecting the beacon to the battery switch pin: fourth stage</i> ....	9
<i>Jerkin details (2)</i> ....	3	<i>Connecting the beacon to the battery switch pin: fifth stage</i> ....	10
<i>Oral inflation valve</i> ....	4	<i>Automatic extraction of battery switch pin as beacon is withdrawn</i> ....	11
<i>S.A.R.A.H. equipment</i> ....	5		
<i>Connecting the beacon to the battery switch pin: first stage</i> ....	6		
<i>Connecting the beacon to the battery switch pin: second stage</i> ....	7		

## LEADING PARTICULARS

<i>Pressure jerkin, Mk. 4, complete</i> ....	Approx. weight 6 lb. (2.7 kg.)
	Ref. No.
<i>Sizes 1 to 6</i> ....	22C/2245 to 2250
<i>Comprising:—</i>	
<i>Garment portion, Sizes 1 to 6</i> ....	22C/2251 to 2256
<i>Life line and toggle</i> ....	22C/1739
<i>Draw rod (S.A.R.A.H. pockets)</i> ....	22C/1862

RESTRICTED

## LEADING PARTICULARS—cont.

Stole	.....	.....	.....	.....	.....	Ref. No. 22C/1847
CO <sub>2</sub> cylinder, Mk. 4, 34 gr.	.....	.....	.....	.....	.....	6D/9432080
Operating head, Type M	.....	.....	.....	.....	.....	6D/1624
S.A.R.A.H. equipment	.....	.....	.....	.....	.....	10D/20094
Lamp, Type B	.....	.....	.....	.....	.....	5A/4216
Whistle and lanyard	.....	.....	.....	.....	.....	22C/1186
Ground/air emergency code	.....	.....	.....	.....	.....	27C/2366

### Introduction

1. At heights up to 40 000 ft. an adequate supply of oxygen to the tissues can be maintained by progressively increasing the amount added to the air being breathed until, at 33 000 ft., 100 per cent oxygen is being supplied through the oxygen mask. Above 40 000 ft. it is necessary to supply 100 per cent oxygen at pressures above ambient. This necessitates the provision of counter pressure on the outside of the body.

2. The jerkin must be worn in conjunction with an automatic pressure demand oxygen regulator. It may be worn with a partial pressure helmet or pressure oxygen mask and an anti-g suit. When an anti-g suit and air ventilated suit are being worn, the hoses emerge from the bottom of the right leg. In the event of damage to the jerkin, provision is made for automatic cut-out of the oxygen supply to the jerkin without interruption of the supply to the pressure helmet. Survival aids (see Leading Particulars), including flotation equipment, are incorporated in the jerkin assembly.

### DESCRIPTION

3. The Mk. 4 Pressure Jerkin (*fig. 1*) is a sleeveless garment, covering the wearer's trunk and upper thighs. It consists of an outer garment of terylene fitted with a nylon lining which covers the whole of the inside of the garment with the exception of the seat. An opening from throat to centre of the left thigh can be closed by an incorporated sliding fastener. An inflatable bladder, of 2-ply rubberised silk, is accommodated between the outer garment and the lining and secured in position by tabs located at the edges, the bottom of the lining and round the armholes. Access to the bladder is gained via an aperture in the lining on the left-hand side of the jerkin. This aperture can be closed by the sliding fastener (*fig. 2*).

4. A transverse opening across the back of

the outer garment, also fitted with a sliding fastener, provides access to a series of lacing cords. These cords, located at the back and at each side (*fig. 3*) enable the jerkin to be adjusted to the wearer's girth. When making adjustments, all ancillary equipment is to be stowed on the jerkin.

5. Shoulder pads, composed of rectangular rubber blocks contained in terylene fabric, are sewn to the outer garment to obtain a better fit for parachute shoulder harness.

### Oxygen supply

6. An aperture in the outer garment, just below the right-hand lobe of the stole cover, accommodates a screwed, flanged connector which is introduced, via a jerkin valve, into the aircraft oxygen system. A T-junction connector in the oxygen supply tube is routed through a retaining loop on the lower right-hand side of the outer garment to engage with the flanged connector.

### Note . . .

*The flanged connector is fitted with a flexible cap. This cap must be removed before the jerkin valve can be connected, but should be refitted at all times when the hose is disconnected.*

7. During flight at high altitudes, oxygen from the main aircraft supply passes through the demand regulator into the jerkin bladder and is breathed through the wearer's oxygen tube and mask. The regulator is designed to give correct pressure breathing characteristics without any control by the user.

8. In front of, and adjacent to, the flanged connector is a pair of matching flaps having eyelets at their edges so that they can be overlapped and laced together. In the laced condition, they form a tunnelled keeper for the wearer's oxygen mask hose.

RESTRICTED

**Stole**

9. The jerkin is fitted with an inflatable stole and a stole cover similar to those incorporated in life jackets. An opening in the back of the cover provides access for inserting the stole. This opening can be closed by an attached sliding fastener. The stole is secured in position inside the cover by press studs fitted to the bases of the lobes and the lobes of the cover are folded and closed by similar fasteners located at the edges. The stole is inflated with carbon dioxide (CO<sub>2</sub>) from an operating head attached to a supply cylinder. An integral inflation tube (with an incorporated oral inflation valve) enables the pressure within the stole to be "topped-up" by mouth.

**CO<sub>2</sub> cylinder**

10. Inflation mechanism for the stole comprises a 34 gramme supply cylinder fitted with a Type M operating head, and the connection from the head to a Schrader valve on the stole. This valve is mounted in a rubber housing which is integral with the stole. For detailed information on the cylinder and the charging head, reference should be made to A.P.1182C, Vol. 1.

11. The cylinder is stowed, with the operating head downwards, in a compartment immediately behind the left-hand lobe of the stole cover, and is retained in position by a sliding fastener.

**Oral inflation valve**

12. This nylon valve (*fig. 4*) is installed in the inlet end of an inflation tube protruding from the left-hand lobe of the stole. It consists of two hollow, cylindrical mouldings, one being a flanged mouthpiece and the other a flanged body into which the mouthpiece is fitted. Within the body, a coiled compression spring is accommodated between an internal shoulder on the body and an external shoulder on the sliding mouthpiece. At its inner end, the mouthpiece is secured, by a rivet, to a rubber sealing washer and a flanged retaining washer. In the "closed" condition of the valve, the compression spring retains the rubber sealing washer in contact with a shoulder formed by a counterbore in one end of the body. The mouthpiece incorporates two projecting tongues which, with the valve in the "closed" condition, abut an internal shoulder in the body and prevent

inadvertent depression of the mouthpiece with consequent loss of air pressure from the stole. Two grooves, diametrically opposite to each other in the body accept the tongues when the mouthpiece is rotated (for alignment) and depressed.

13. For stole inflation, the mouthpiece is rotated until the tongues are aligned with the grooves, and then depressed by mouth as inflation is commenced. Depression of the mouthpiece forces the tongues into the grooves, compresses the spring and pushes the sealing washer away from its seating. Air flows through the mouthpiece bore and out, via two holes positioned diametrically opposite to each other in the mouthpiece walls, to the annular chamber between mouthpiece and body and thence, through the passage-way between the displaced sealing washer and its seating, into the stole. On withdrawal of the valve from the mouth, the spring forces the mouthpiece outwards, and the sealing washer returns to its seating to "close" the valve and function as a non-return valve. The mouthpiece is then rotated to move the tongues out of alignment with the grooves and so lock the valve in the "closed" condition.

**Lifting beackets and life line**

14. Two beackets, comprised of looped nylon webbing straps, are stitched to the outer garment. Located, one on each side of the central opening, they can be fastened together, by a press stud, to provide a means of lifting the wearer from the water if necessary. These lifting beackets are normally covered by the furled stole cover, but become readily accessible following stole inflation. Rip stitches (No. 50 scarlet thread) retain the beackets to the stole cover.

15. A 250 lb. nylon cord life line is secured to the left-hand lifting beacket (*fig. 2*). One end of the cord is stitched to the beacket webbing and the opposite end is attached to a wooden toggle. The hanked line is retained in position on the webbing strap by three bands of P.V.C. tape which are wrapped tightly around the webbing and cord at three places.

**S.A.R.A.H. equipment**

16. S.A.R.A.H. equipment (*fig. 5*) consisting of battery, beacon and speech units,

is carried in pockets on the outer garment. The battery pocket is located on the right-hand side of the garment, the battery being stowed below the beacon and retained in position by straps and buckles. A cover flap for the pocket is secured by press stud

fasteners. Above the pocket, but under its cover flap, are two smaller flaps fitted with loops along their edges. These are fastened together by a nylon draw rod which is passed through the loops from front to rear. They provide a stowage for the beacon unit.



Fig. 1. Pressure jerkin Mk. 4

**RESTRICTED**

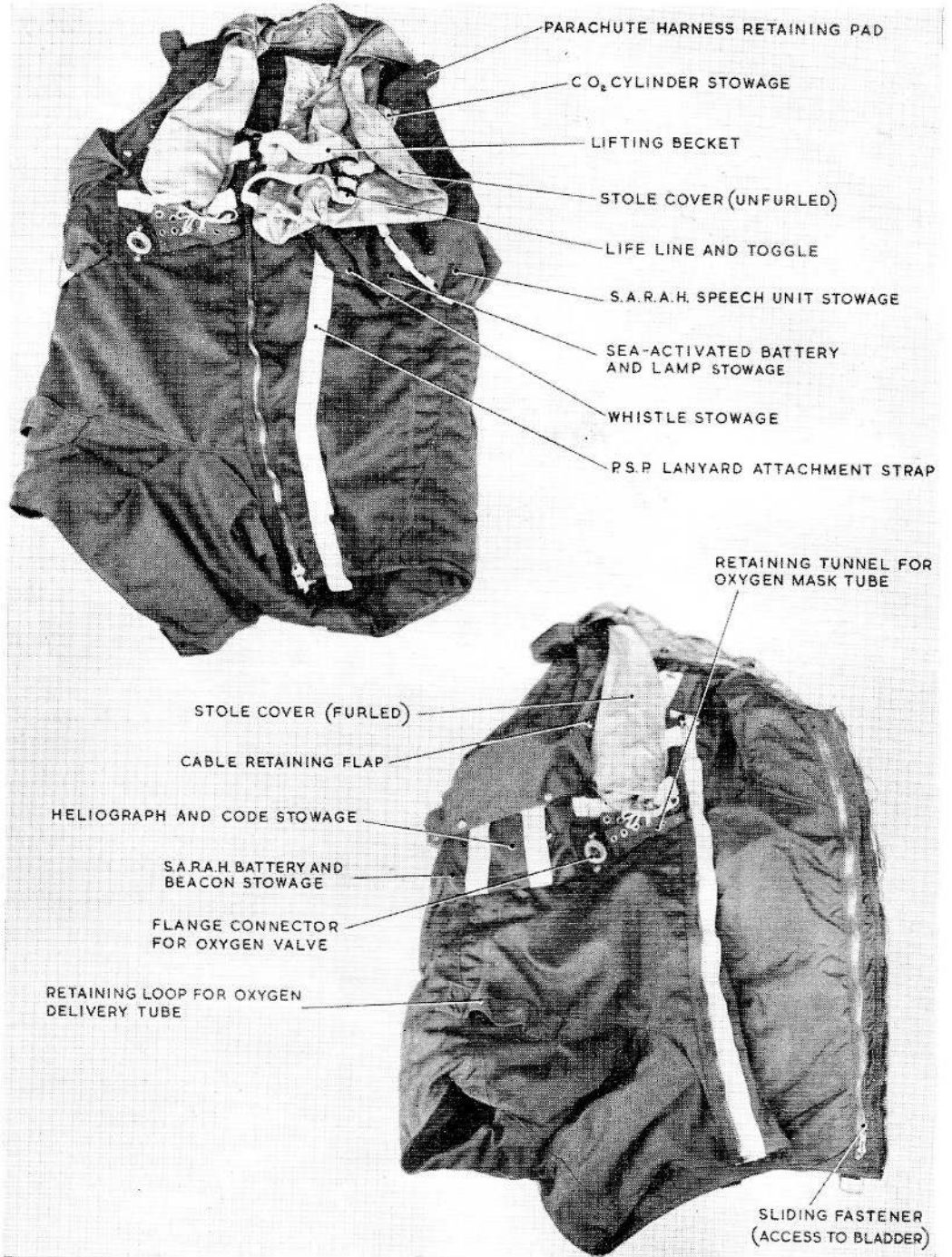

Fig. 2. Jerkin details (1)

RESTRICTED



Fig. 3. Jerkin details (2)

RESTRICTED

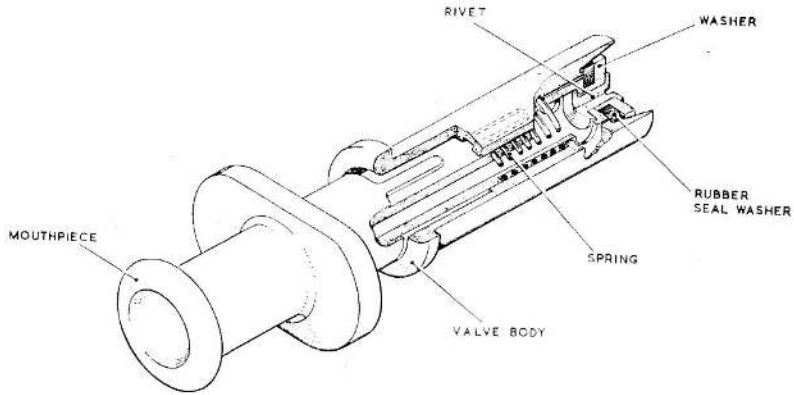

Fig. 4. Oral inflation valve

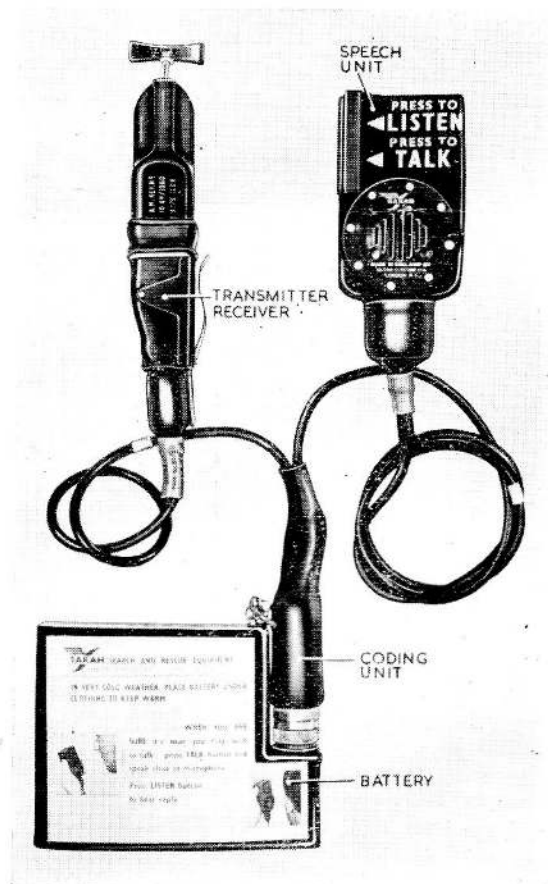

Fig. 5. S.A.R.A.H. equipment

RESTRICTED

17. The pocket for the speech unit, located on the left-hand side of the garment, is also fitted with loops and a nylon draw rod, the rod terminating in a ring handle which is fastened in position by a press stud. Similar fasteners secure a cable retaining flap over the top of the pocket. An interconnecting cable between speech unit and battery is routed around the underside of the stole cover.

18. A reinforced mounting on the right-hand lobe of the stole cover provides an anchorage for the beacon unit when the S.A.R.A.H. equipment is brought into operation.

#### **Heliograph and emergency code**

19. A small compartment on the outside of the S.A.R.A.H. battery pocket accommodates a heliograph and a ground/air emergency code card. The compartment is fastened to the pocket by a press stud.

#### **Whistle**

20. A whistle, together with its retaining lanyard, is housed in one of two compartments in a single pocket located in front of the speech unit pocket. The pocket is secured by a single flap incorporating two press studs. An eyelet on the top edge of the compartment is provided to enable the lanyard to be secured to the garment.

#### **Lamp and sea-activated battery**

21. These items are accommodated, together with a retaining lanyard, in the other compartment of the whistle pocket. Both the lanyard and a battery stud extractor cord are secured to an eyelet on the top edge of the compartment. For detailed information on the lamp and battery, reference should be made to A.P.4343, Vol. 1, Book 3.

22. A rubber button on the left-hand lobe of the stole cover forms an anchorage for the lamp when the lamp is used in an emergency.

#### **Personal survival pack attachment**

23. A single non-adjustable nylon webbing strap, sewn down the left-hand side of the outer garment, terminates in a small loop. This loop provides attachment for the quick release fitting of a personal survival pack lanyard.

### **SERVICING**

24. Servicing should be carried out in accordance with the instructions given, and

at the periods stipulated in Vol. 4. When all items have been found or made serviceable, they should be assembled in accordance with the instructions given in later paragraphs.

#### **After immersion in salt water**

25. The operating head, CO<sub>2</sub> cylinder, lamp and battery, whistle, heliograph, ground/air emergency code and S.A.R.A.H. units are to be removed from the jerkin. The lamp and battery and the S.A.R.A.H. units are to be returned to the electrical and the radio servicing bays respectively, with attached labels giving details of the immersion. The screwed flanged connector must be blanked-off to prevent ingress of water to the bladder. All remaining items, together with the jerkin, are to be thoroughly rinsed in successive changes of clean, cold water and allowed to dry naturally away from sunlight and all sources of artificial heat. After drying, the CO<sub>2</sub> cylinder is to be serviced and then returned to the appropriate Maintenance Unit clearly marked "This cylinder has been immersed in salt water." After having been immersed in salt water, the jerkin is to be used for wet drills only.

#### **◀ Removal and charging of inflation mechanism ▶**

26. If the cylinder is to be unscrewed from the operating head, whether for check weighing or for re-charging, the locking screw on the head should first be released. Failure to observe this precaution will result in damage to the threads on the cylinder. The method of charging the cylinder is in A.P.1182C, Vol. 1, Book 2, Sect. 3, Chap. 5. ▶

27. Care should be exercised when removing the cylinder connection to prevent damage to the stole Schrader valve. Both the operating head and the Schrader valve should be held firmly while the coupling nut is unscrewed (using two spanners). It is very easy to pull the Schrader valve out of its mounting.

#### **Testing of stole**

28. During periodic servicing, the jerkin stole should be inflated through the oral inflation valve to check for satisfactory inflation and valve operation.

29. For stole pressure testing, the following items of equipment are required:—

Manometer (reading up to 40 in. water pressure)

T-piece (¼ in. dia. bore)

Rubber tubing (¼ in. dia. bore)

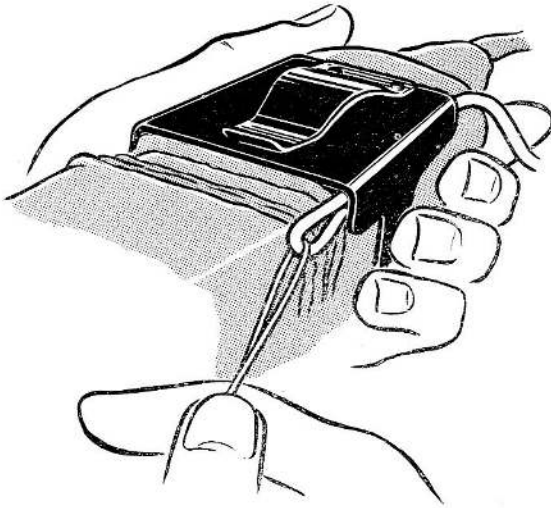

**Fig. 6. Connecting the beacon to the battery switch pin: first stage**

- (1) Remove the stole from the cover and take out the Schrader valve.
- (2) Connect the Schrader valve stem to a manometer.
- (3) Inflate the stole through the oral inflation valve to give a reading of 30 cm. (11.75 in.) water pressure.
- (4) Leave for 10 min. Pressure will not fall more than 2 cm. if the stole is serviceable.
- (5) Disconnect the stole from the manometer and refit the Schrader valve.
- (6) Inflate the stole and immerse, first the tip of the Schrader valve and then the oral inflation valve to check for leakage which will be revealed by the presence of bubbles. Renew any valve which leaks.
- (7) Test the oral inflation valve by turning the mouthpiece anti-clockwise to unlock it, depress the mouthpiece and then release it. It should return under the action of the spring. If it fails to return or is sluggish in action, it is to be renewed.

#### Oral inflation valve renewal

30. Air leakage through the valve cannot be rectified. The defective valve must be renewed. To renew a valve, proceed as follows:—

- (1) Carefully remove the stole inflation tube from the valve body by rolling the tube towards the stole. The end

of the tube should be eased off the valve body with the thumbs, then bent backwards towards the stole and rolled off. Alternatively, the tube may be pushed off, but no attempt must be made to pull the valve out of the tube.

(2) Having removed the old valve, roll the tubing back and clean the inner surface to remove any foreign matter.

(3) Wet the outer surface of the body of the new valve with clean water, insert the valve body and unroll the tube. Ensure that the valve is secured and will not come out easily due to the presence of excessive water.

**Note . . .**

*French chalk is not to be used to assist in valve insertion in inflation tube.*

(4) Test the stole as described in para. 28 and 29.

**Note . . .**

*When a new valve is fitted, ensure that the flat sides of the mouthpiece external flange are parallel with the flanged base of the inflation tube when the mouthpiece is in the "unlocked" position.*

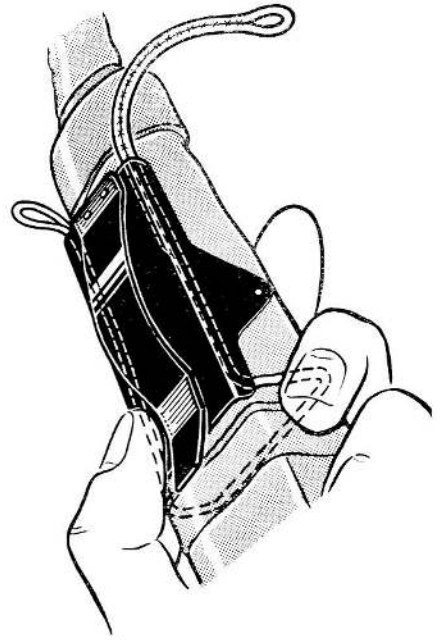

**Fig. 7. Connecting the beacon to the battery switch pin: second stages**

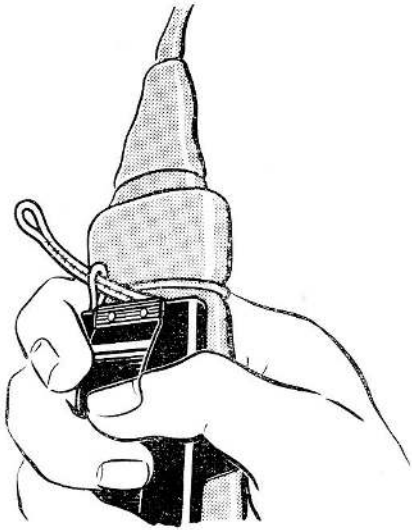

**Fig. 8. Connecting the beacon to the battery switch pin: third stage**

#### **CO<sub>2</sub> cylinder life**

31. Reference should be made to the appropriate chapter in A.P.1182C, Vol. 1 for detailed information on the limitations and tests approved for these cylinders.

#### **Other limitations**

32. Until further notice the following limitations are imposed:—

- (1) Stole. Three replacement oral inflation valves.
- (2) Oral inflation valve. Four immersions in salt water.
- (3) Jerkin. Sixteen immersions in salt water.

33. When these limitations are reached, the items are to be renewed.

### **ASSEMBLING**

#### **Inserting the stole**

34. Insert the stole through the opening in the stole cover, and slightly inflate it to ensure that it lies flat and is not twisted. Secure the bottom of each lobe with the press stud fasteners. Pass the Schrader valve and oral inflation tube through the respective apertures, deflate the stole, ensure that the oral inflation valve is in the "locked" condition and insert the tube into the keeper. Close the aperture in the stole cover.

#### **Fitting the CO<sub>2</sub> cylinder and operating head**

35. Assemble these units to the jerkin in the following manner:—

(1) If the cylinder is new, remove the plastic cap.

(2) Loosen the locking screw, screw the cylinder into the operating head hand tight and secure in with the locking screw.

(3) Release the tape attached to the retaining clip in the coupling nut of the operating head and remove the clip.

(4) Remove the coupling nut.

(5) Check to ensure that the lip and threads of Schrader block stem and the threads and internal seating of the coupling nut are clean and undamaged.

(6) Screw the coupling nut, finger tight on the Schrader block stem until the end of the stem meets the seating inside the nut and then, using two spanners, tighten the nut another quarter of a turn.

(7) Push the gas outlet boss on the operating head into the nut with a slight twisting movement.

(8) Check for correct assembly alignment by feeling to ensure that the flat surface of the Schrader block is in the same plane as the long axis of the gas cylinder and that the stole is not twisted.

(9) Insert the coupling nut retaining clip and wrap the tape round the nut once each side of the clip and tie the

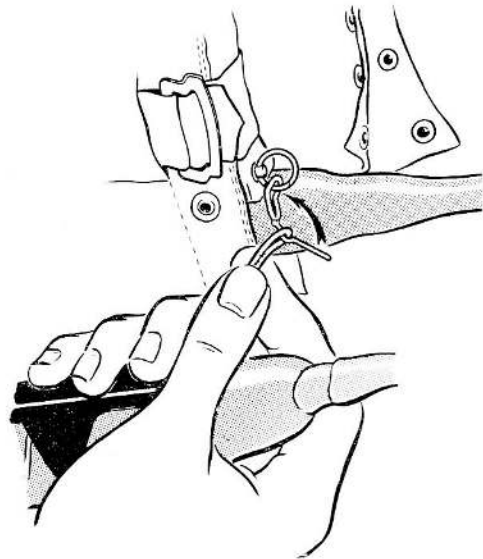

**Fig. 9. Connecting the beacon to the battery switch pin: fourth stage**

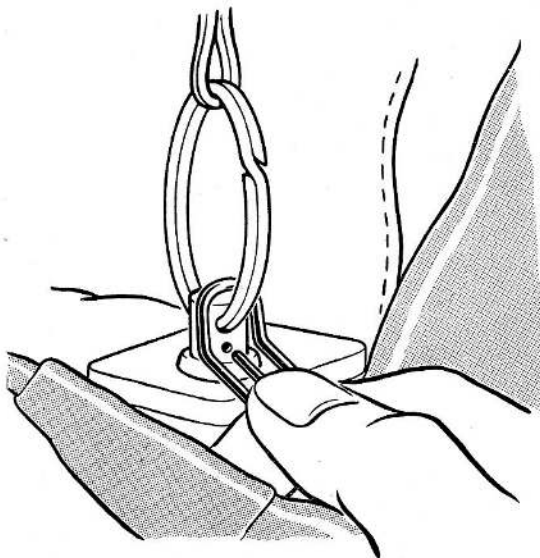

**Fig. 10. Connecting the beacon to the battery switch pin: fifth stage**

ends together tightly with a reef knot.

(10) Check the operating head to ensure that the sealing thread on the cap is intact.

(11) Place the cylinder in its stowage, wrap the tapes round the neck of the gas outlet union, tie them together tightly with a reef knot, and close the sliding fastener.

**Note . . .**

*It may not be possible to untie the tapes referred to in sub-para. (9) and (11) without damaging them. Damaged tapes are to be renewed.*

**Stowing the S.A.R.A.H. equipment**

36. Stow the S.A.R.A.H. units in the following manner:—

(1) Place the battery in its pocket, with the coding unit facing the front of the jerkin, and secure it in position with the straps and buckles.

(2) Holding the beacon as shown in fig. 6, loop a length of suitable wire or cord through the length of cord on the beacon, thread it between the clip and the beacon and then pull it through.

(3) Pass the cord round the beacon and again thread it under the clip, positioning it as shown in fig. 7.

(4) Pass the longer end through the loop at the other end (fig. 8).

(5) Place the loop at the end of the cord over the beacon switch release pin as shown in fig. 9 and position the pin, as shown by the arrow, so that it retains the loop of cord.

(6) Raise the switch plunger (fig. 10), by lifting the ring with a loop of cord, and insert the switch pin into the hole which becomes exposed when the plunger is lifted. Fig. 11 shows how the switch pin is extracted when the beacon is withdrawn.

(7) Place the beacon in its stowage over the battery pocket, draw the edges of the flaps together, and secure them by passing the draw rod through the loops, from front to rear, using alternate loops.

(8) Pull over the outer flap and secure it with the press stud fasteners.

(9) Stow the loop of cable, running

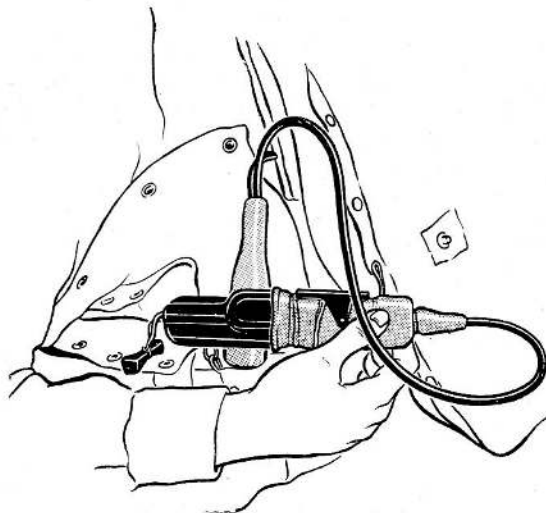

**Fig. 11. Automatic extraction of battery switch pin as beacon is withdrawn**

**RESTRICTED**

between the battery and the beacon, under the retaining flap adjacent to the armhole in the jerkin.

(10) Route the battery cable through the retaining flaps at the armhole and neck respectively,

(11) Stow the speech unit, together with surplus cable, in the pocket on the front left-hand side of the jerkin, and close the pocket by passing the draw rod upwards through the loops.

(12) Secure the finger ring on the draw rod with the press stud fastener located at the bottom of the pocket.

#### **Stowing the lamp and sea-activated battery**

37. Prior to inserting the battery in its pocket, ensure that there is a length of cord, approximately 3½ in. long, between the studs on the battery case and the corner eyelet at the top of the pocket. This length of cord is sufficient to permit the battery to be pulled out of the pocket before the studs are extracted to allow the water to enter. A second length of cord should be knotted, at one end, to the same corner eyelet, and the opposite end secured to the battery case (utilizing the existing hole in the case). This cord, acting as a retaining lanyard, should be 33 in. long. Both cords should be tied down with three half-hitches and have the ends sewn down with No. 40 thread.

38. The method of packing new lamps and batteries originally adopted resulted in the cable taking up a permanent set at the point where it emerges from the plug, especially when the equipment had a long shelf life before being issued. As a result, when the equipment was brought into use or the cable disturbed for examination, there has been a tendency for the insulation to split and open out at the point of set. This tendency has been aggravated by repeated tight wrappings during periodic servicing. At the intervals given in Vol. 4, special attention is to be given to the examination of the cable to ascertain whether splitting of the insulation has occurred. Lamps with exposed conductors are to be rejected, but those with marked

or kinked cable may be put back into service if there is no splitting of the insulation. When re-stowing lamps and batteries, the cable is to be led away from the plug in a bend of approximately 1 in. across, wrapped round four fingers and the coil so formed secured to the plug side of the battery with a rubber band. The lamp is to be located in a suitable position for stowage flat side up on top of the flex. When stowing the equipment ensure that the loop leading away from the plug is not flattened. ►

39. Stow the battery in the pocket; studded side forward, with the longer cord looped across the bottom of the case to prevent snagging on withdrawal.

#### **Fitting the life line and toggle**

40. Wrap the untoggled end of the line around the left-hand lifting becket and secure with knots. Stitch the knotted part of the line to the becket and then hank the line to an approximate length of 2½ in. Position the hanked line on the becket, near to the edge of the webbing reinforcement, and secure with three bands of ¼ in. wide P.V.C. tape (*Ref. No. 32B/769*) wrapped tightly round the hanks of cord and the webbing, as shown in fig. 2. Each band should be wrapped twice round and then stuck down, the locations of the bands being—one at the centre, adjacent to the toggle, and one at each side, at a position approximately ½ in. in from each end of the hanked cord.

#### **Stowing the whistle**

41. Pass the end of the whistle lanyard through the eyelet in the hem at the top of the pocket and secure with three half-hitches. Sew the loose end to the standing part of the cord with three stitches of No. 40 linen thread. Hank the lanyard and place it, beside the whistle, in the pocket.

#### **Stowing the heliograph and emergency code**

42. Insert the heliograph and the ground/air emergency code in the small compartment on the front of the S.A.R.A.H. battery pocket and engage the press stud fastener.

This file was downloaded  
from the RTFM Library:

Link: [www.scottbouch.com/rtfm](http://www.scottbouch.com/rtfm)

Please see site for usage terms,  
and more aircraft documents.

