

RESTRICTED

AIR PUBLICATION

A.P. 1182E

PARTIAL PRESSURE HELMET, TYPE E

*Vol. 1, Sect. 1, Chap. 23*

*A.L. 98, Jan. 63*

GENERAL AND TECHNICAL INFORMATION

BY COMMAND OF THE DEFENCE COUNCIL



Ministry of Defence

FOR USE IN THE  
ROYAL AIR FORCE

(Prepared by the Ministry of Aviation)

## Chapter 23

## PARTIAL PRESSURE HELMET, TYPE E

## LIST OF CONTENTS

	Para.		Para.
<i>Introduction</i> ... ..	1	<i>Balance valve</i> ... ..	32
<i>DESCRIPTION</i> ... ..	5	<i>Hinge mechanism</i> ... ..	33
<i>Shell casing</i> ... ..	6	<i>SERVICING</i> ... ..	36
<i>Pressure bladder details</i> ... ..	7	<i>Lining</i> ... ..	37
<i>Valve, compensated, breathing</i> ... ..	12	<i>Cleaning</i> ... ..	38
<i>Pressure visor</i> ... ..	16	<i>TESTING</i>	
<i>Pressure visor release mechanism</i> ... ..	17	<i>Visor arm torsion test</i> ... ..	40
<i>Hinge mechanism</i> ... ..	18	<i>Helmet pressure test</i> ... ..	41
<i>Anti-glare visor</i> ... ..	22	<i>REMOVAL AND ASSEMBLY</i> ... ..	42
<i>Sliding fastener assembly</i> ... ..	23	<i>Removing the compensated breathing valve</i> ... ..	43
<i>OPERATION</i>		<i>Installing the compensated breathing valve</i> ... ..	44
<i>Mouthdoor</i> ... ..	24	<i>Donning the helmet</i> ... ..	45
<i>Valve, compensated, breathing</i> ... ..	26	<i>Removing the helmet</i> ... ..	46
<i>Pressure visor release (manual)</i> ... ..	28		
<i>Pressure visor release (automatic)</i> ... ..	30		

## LIST OF ILLUSTRATIONS

	Fig.
<i>Partial pressure helmet, Type E</i> ... ..	1
<i>Pressure bladder details</i> ... ..	2
<i>Compensated breathing valve details</i> ... ..	3
<i>Pressure visor release mechanism</i> ... ..	4
<i>Hinge mechanism</i> ... ..	5
<i>Helmet pressure test rig</i> ... ..	6

RESTRICTED

## LEADING PARTICULARS

*Partial pressure helmet, Type E, sizes:—*

<i>Standard shell 14 in. — 15 in. Standard neck</i>	...	...	...	...	...	Ref. No. 22C/2093
<i>Standard shell with long neck</i>	...	...	...	...	...	Ref. No. 22C/2094
<i>Standard shell 15½ in. — 16 in. Standard neck</i>	...	...	...	...	...	Ref. No. 22C/2095
<i>Standard shell with long neck</i>	...	...	...	...	...	Ref. No. 22C/2096
<i>Standard shell 16½ in. neck and over. Standard neck</i>	...	...	...	...	...	Ref. No. 22C/2097
<i>Standard shell with long neck</i>	...	...	...	...	...	Ref. No. 22C/2098
<i>Wide shell 14 in. — 15 in. Standard neck</i>	...	...	...	...	...	Ref. No. 22C/2099
<i>Wide shell with long neck</i>	...	...	...	...	...	Ref. No. 22C/2100
<i>Wide shell 15½ in. — 16 in. Standard neck</i>	...	...	...	...	...	Ref. No. 22C/2101
<i>Wide shell with long neck</i>	...	...	...	...	...	Ref. No. 22C/2102
<i>Wide shell 16½ in. neck and over. Standard neck</i>	...	...	...	...	...	Ref. No. 22C/2103
<i>Wide shell with long neck</i>	...	...	...	...	...	Ref. No. 22C/2104
<i>Special size</i>	...	...	...	...	...	Ref. No. 22C/2105
<i>Working pressure</i>	...	...	...	...	...	1.5 to 2.0 lb/in. <sup>2</sup>
<i>Weight (approx.)</i>	...	...	...	...	...	5 lb. 14 oz.

*Kit, Type E partial pressure helmet consisting of:—*

<i>Case, transit</i>	...	...	...	...	...	Ref. No. 22C/2144
<i>Helmet</i>	...	...	...	...	...	As above
<i>Lining, head, wide, spares (3 off) or</i>	...	...	...	...	...	Ref. No. 22C/2139
<i>Lining, head, standard, spares (3 off)</i>	...	...	...	...	...	Ref. No. 22C/2201
<i>Cover, protection</i>	...	...	...	...	...	Ref. No. A/0111
<i>Cloth, de-misting</i>	...	...	...	...	...	Ref. No. C/0190
<i>Report, inspection and test</i>						

RESTRICTED

## Introduction

1. The partial pressure helmet (*fig. 1*) is designed to give short term pressure protection in the event of cabin pressure failure, and to provide an efficient oxygen mask and breathing system for normal high altitude flying. It is worn in conjunction with a pressure jerkin and an anti-g suit. In normal flight it provides all the usual services and protection, including reasonable crash protection.

2. In addition to the oxygen mask, the helmet assembly incorporates earphones, microphone, microphone selector switch, anti-glare visor and an automatically-operated pressure visor with a manual override. A manually-operated, spring-loaded door in the lower front section of the helmet governs access to the wearer's mouth. The oxygen mask allows unpressurised oxygen breathing in normal conditions with the pressure visor open. When pressurised, the balance between intake and exhaust is maintained by a compensated inspiratory-expiratory valve. The helmet is lined with a detachable lining of pure silk which greatly adds to its comfort and hygiene.

3. The helmet is pressurised by oxygen delivered, through a valve on the pressure jerkin, from the regulator in the aircraft oxygen system. It is designed for a working pressure of  $1\frac{1}{2}$  to 2 lb./in.<sup>2</sup> when worn with the clothing described in *para. 1*. It is normally tested at 1.25 lb./in.<sup>2</sup> before each flight, and should be proof-tested at 1.5 lb./in.<sup>2</sup> at the periods stipulated in the relevant servicing schedule.

4. When not in use, the helmet should be kept in its transit case. When packing and unpacking, care should be taken that the main oxygen connector hose is properly folded and not kinked. Details of the helmet kit, together with the various sizes of helmet available, are given in the Leading Particulars.

## DESCRIPTION

5. Principal items of the helmet assembly consist of a shell casing, pressure bladder and pressure visor.

### Shell casing

6. The shell casing is of Durestos, with additional laminates of terylene to give protection on impact. Apertures in the casing provide for forward viewing and the accommodation of accessory equipment, including 'handed' hinge assemblies which control the travel of the transparent pressure visor. A transverse groove around the rear end of the casing forms a housing for a spring and chain assembly which is anchored to, and pre-loads, a pivot arm secured to each hinge assembly. Slots, also in the rear part of the casing, form anchorages for six helmet adjustment straps. A spring-loaded, hinged door, together with its rubber mounting block, is fitted over a mouth opening in the lower front part of the casing. The door is retained in the closed position by a hand-operated swivel catch, and is safe from accidental release.

### Pressure bladder assembly

7. This component (*fig. 2*) is a rubber moulding incorporating two separate compartments. One compartment forms an oxygen mask and the other a head enclosing bladder. A seal for the pressure visor is an integral part of the pressure retaining bladder.

8. The oxygen mask compartment is sealed off from the pressure bladder by two membranes, positioned one across each cheek. The mask accommodates a compensated inlet-outlet valve and this provides for oxygen breathing under normal or pressure conditions. This valve is of special design for the dual purpose of inward and outward breathing. It is compensated for pressure breathing with a minimum back pressure loading. The mask incorporates a connector for the attachment of an emergency oxygen supply pipe.

RESTRICTED

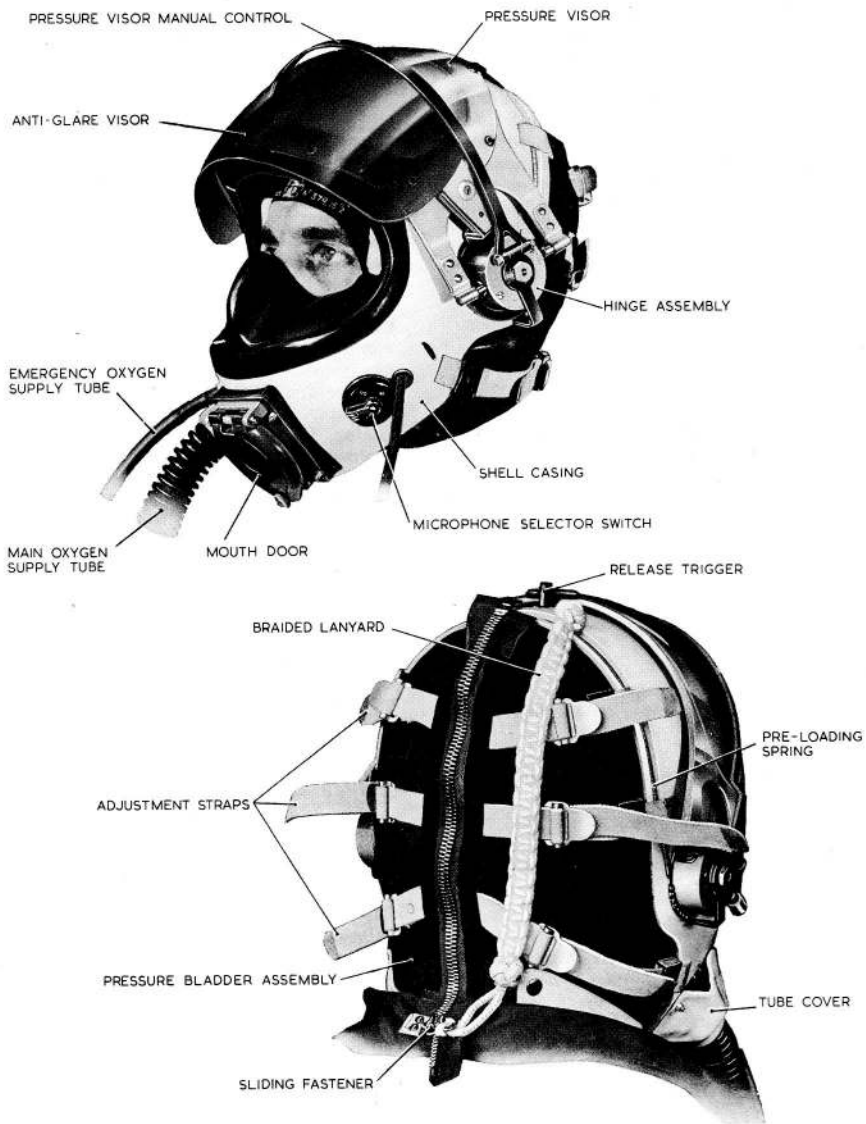

Fig. 1. Partial pressure helmet-Type E

**RESTRICTED**

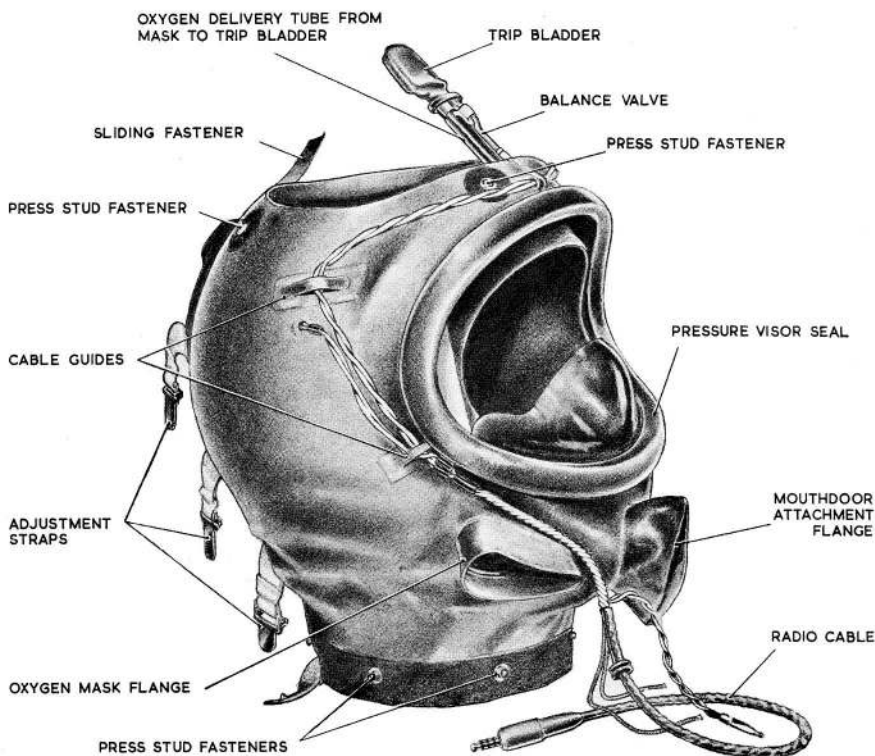

Fig. 2. Pressure bladder details

9. From the oxygen mask, a delivery tube is routed upwards to connect with the inlet end of a trip bladder. An outlet tube from the trip bladder is routed to one end of a centrally flanged balance valve. From the opposite end of the valve, a second tube is routed to the pressure bladder. A rubber sleeve encloses the valve and the end attachment of each tube, and is secured by No. 40 linen thread. On each side of the flange, the valve is drilled to allow the passage of oxygen to and from the pressure bladder during pressurisation and de-pressurisation of the helmet.

10. The trip bladder is housed within a release box assembly and, on pressurisation, actuates this mechanism to release the pressure visor from the 'open' position.

11. Earphones and a microphone are accommodated in moulded pockets in the pressure bladder. The earphones fit into recesses in polyurethane pads and are unnoticeable in wear. Moulded polyurethane pads, encasing the head (but not the face), impart a relatively high sound exclusion property to the helmet. Press stud fasteners secure the moulded pads to the pressure bladder.

RESTRICTED

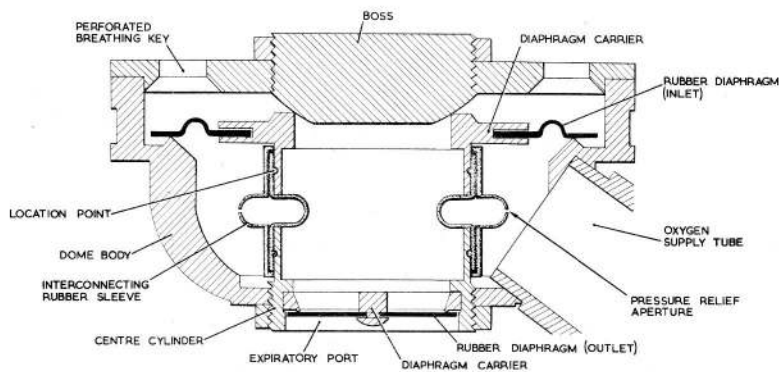

INSPIRATORY-EXPIRATORY VALVE

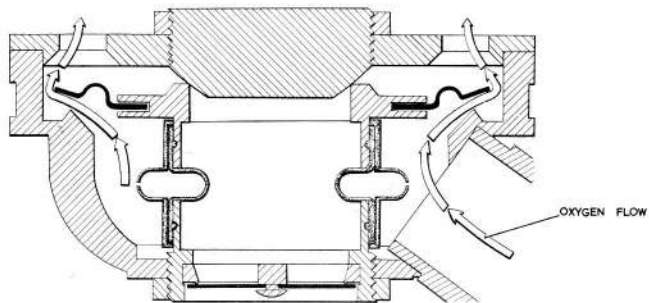

INSPIRATION

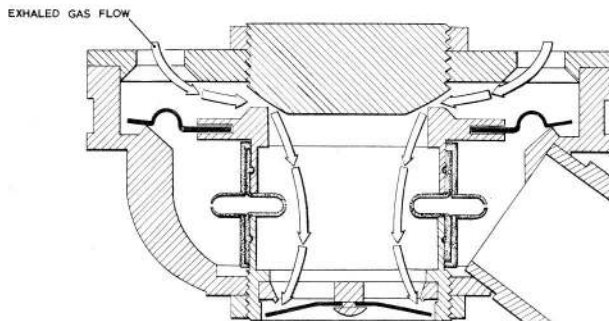

EXPIRATION

Fig. 3. Compensated breathing valve details

**RESTRICTED**

**Valve, compensated, breathing**

12. This dual purpose valve (*fig. 3*) is housed in the oxygen mask. It consists mainly of a centre cylinder, a bossed key, an outlet assembly and a dome-shaped body. The centre cylinder comprises two separate sections interconnected by rubber inner and outer sleeves. Each section has a flanged extremity which carries an annular rubber diaphragm, one diaphragm controlling oxygen flow into the mask, and the other controlling the flow of exhaled gas from the mask. In the inoperative state, both diaphragms seat against knife-edge annular projections formed around the inner surfaces of the cover shell and the outlet assembly respectively. The inlet diaphragm carrier seats against the curved inner shoulder of a boss screwed through the centre of a perforated key.

13. The key, forming one end of the valve assembly, has a series of drilled holes which permit the passage of oxygen to, and exhaled gas from, the oxygen mask. At the opposite end of the valve, an outlet assembly, mounted within the centre cylinder flange, has ports which serve as passage ways for the exhaled gas. The dome-headed centre piece of the outlet assembly is grooved to form a support for the outlet rubber diaphragm.

14. The two interconnecting rubber sleeves referred to in para. 12 enclose the inner ends of the centre cylinder sections, the inner sleeve being keyed into locating grooves in the outer surface of the sections. The sleeves are arranged to provide a central pocket to separate the two sections of the centre cylinder, and to allow the innermost section independent movement. A small hole in the outer sleeve acts as a pressure relief to prevent any pressure build up which could affect the satisfactory operation of the valve.

15. The dome-shaped body screws on to the outlet flange of the centre cylinder. A flanged, cylindrical extension protrudes from the body for attaching the oxygen delivery hose.

**Pressure visor**

16. The pressure visor consists of two perspex transparencies separated by a

glasscloth - perspex laminated mount which provides an air space to give protection against freezing of the inner transparency for a short period. Both ends of the visor terminate in twin arms which are bolted to cranks located, diametrically opposite to each other, on the two 'handed' hinges protruding from the shell casing. Each end of an external semi-circular bar is bolted to the pre-loaded pivot arms secured to each hinge referred to in para. 6. This bar provides manual opening and closing of the pressure visor by natural, instinctive movements. Generally the visor closes, seals and locks automatically, but a pull down on the visor bar functions any of these movements, should any unforeseen circumstances make manual functioning necessary.

**Pressure visor release mechanism**

17. The pressure visor is retained in the 'open' position by spring-loaded, ball-ended plungers which grip around the upper end of a centrally pivoted trigger forming part of a release box assembly (*fig. 4*). The upper end of the trigger protrudes above the top of the shell casing, and the lower end abuts a roller fixed to a hinged and spring-loaded trip plate. An adjustment screw governs the correct setting of the roller relative to the trigger. The trip bladder (*para. 9*) is housed in the compartment formed by the under-surface of the casing and the upper surface of the trip plate. An adjusting sleeve in the rear section of the box governs the setting of the trip plate spring. After automatic operation, the trigger returns to the upright position under the action of its own spring-loading.

**Hinge mechanism**

18. A pressure visor hinge (*fig. 5*) is fitted on each side of the shell casing. These hinges serve to position the pressure visor accurately over the visor opening in the shell casing and pressure bladder and to lock the visor against the visor seal during pressurisation. When the helmet is unpressurised, the hinges allow the visor to be swung upwards for retention by the trigger of the release box assembly.

RESTRICTED

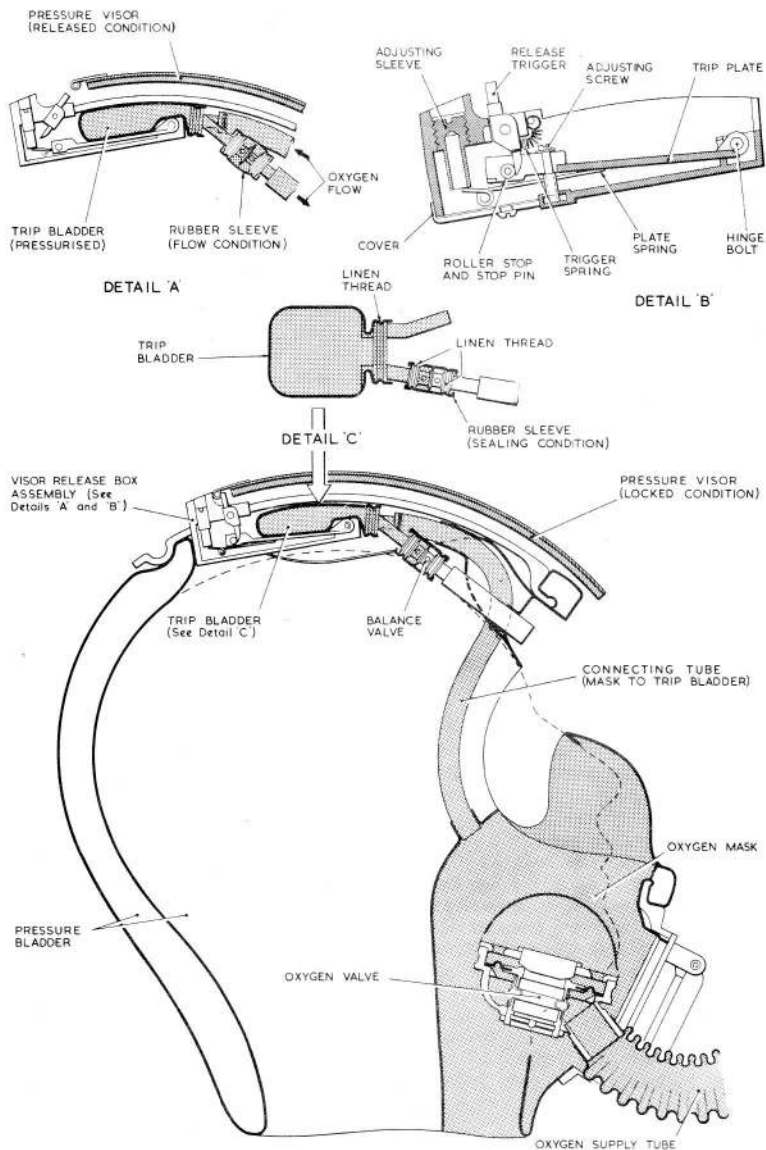

Fig. 4. Pressure visor release mechanism

RESTRICTED

19. Each hinge comprises a flanged, cylindrical body mounted on a base plate and enclosed by a sleeving cover which is secured by screws. The bore of the body accommodates a spring-loaded bevel gear and a pinion which are interconnected with a cross shaft and a centre spindle. A bearing plate is interposed between the body and the body cover and retained by two countersunk screws. The centre spindle protrudes through the centres of base plate, bearing plate and body cover, one end being secured to the base plate by a ring nut. At its opposite end, the spindle has an internally threaded boss section which protrudes through the bearing plate and body cover to accommodate the visor manual bar and hinge arm assembly. The boss threads accept a ring nut which is fitted over the end of the spindle to retain the bar and hinge arm assembly in position.

20. An internally located cam and two externally located cranks are pinned to the cross shaft. The cam retains an inter-locking ball in its housing in the body and base plate. Rotation of the cam will align a cut-away section of its periphery with the ball which can then rise and unlock the body from the base plate. Rotational movement of the body is limited by a stop screw which abuts either end of a curved channel cut in the body base. Rotational movement of the cam is limited by a stop pin which abuts either of two shoulders on the cam.

21. Each crank is threaded to provide attachment for the arms of the pressure visor.

#### Anti-glare visor

22. An anti-glare visor, consisting of a dark perspex transparency, is fitted to the shell by means of nylon brackets. Friction discs retain it in any desired position. It is located outside the pressure visor and is manually operated. It can be used irrespective of the pressure visor position.

#### Sliding fastener assembly

23. The helmet incorporates a lanyard-

operated sliding fastener assembly for use during fitting and removing operations. One end of the braided lanyard is anchored to the shell casing, and the opposite end is secured to a slide fastener which, in turn, is attached to the right-hand line of teeth. This line extends beyond the lower limit of the left-hand line of teeth, the extra run of teeth being brought into use when a speedy or emergency removal of the helmet is desired. A safety catch is fitted at the lower extremity of the left-hand line of teeth.

## OPERATION

### Mouthdoor

24. The mouthdoor can only be opened by a squeeze on both sides of the release catch mechanism simultaneously. This action opens claws to free the catch. The door then springs open.

#### Note ...

*The upper surface of the door is coloured red and, when open, is in the wearer's line of sight as a warning to close it after use.*

25. Closing the mouthdoor is done manually by lowering the door with the first finger and lifting the catch with the thumb. When the catch is in position the door is sealed.

### Valve, compensated, breathing

26. On inhalation oxygen is drawn into the valve from the supply tube. The inlet diaphragm is forced away from its seating, allowing the oxygen to flow past and through the holes in the perforated key. Pressure on the inlet diaphragm retains the inlet diaphragm carrier in contact with the shoulder on the base boss, thus preventing any escape of oxygen into the bore of the centre cylinder.

27. On exhalation, the gas flows out through the holes in the perforated key. This pressure forces the inlet diaphragm against its seat-

ing, so blanking-off the oxygen supply from the oxygen delivery tube, and acts on the inlet diaphragm carrier to move the carrier from its seating against the valve boss. The gap thus formed permits the exhaled gas to flow into, and through, the centre cylinder bore. At the outlet end of the centre cylinder, the gas forces the outlet diaphragm away from its seating and exhausts, through the expiratory port, from the valve.

#### Pressure visor release (manual)

28. Manual closing and opening of the visor is by natural, instinctive movements of the visor bar. For visor closing, the bar is pulled downwards, and for visor opening the bar is pushed upwards. A downward pull on the bar rotates the hinges which, in turn, actuate the pressure visor. Downward pressure on the visor forces the spring-loaded plungers on the visor to open around the trigger of the release box assembly and so release the visor. An upward push on the bar rotates the hinges in the opposite direction and the visor travels upwards until the plungers grip the trigger to retain the visor in the open position.

29. Downward travel of the visor is assisted by the spring-loading of the pivot arm attached to each hinge assembly.

#### Pressure visor release (automatic)

30. Automatic release occurs each time the oxygen supply regulator in the aircraft system supplies oxygen to the helmet at a pressure in excess of cabin pressure. A surge of this pressure in the oxygen mask is transmitted to the trip bladder, expansion of which actuates the mechanism which releases the visor to close and lock under its own spring-loading.

31. The release mechanism operates by the expansion of the trip bladder which depresses the trip plate until the incorporated roller stop ceases to contact the release trigger. Once freed, the trigger is pulled forwards by the visor plungers, the visor moving under the action of the spring-loaded pivot arm and hinge assemblies referred to in para. 6. On visor release, the trigger is returned to the upright position by its own

spring. Pressure required to actuate the release mechanism is 22–26 mm.Hg.

#### Balance valve

32. On pressurisation of the helmet, oxygen is routed from the trip bladder into the pressure bladder via the balance valve (para. 9). The increased pressure from the trip bladder forces the rubber sleeve away from the valve central flange, thus providing a passageway for oxygen flow from the outlet port on one side of the flange to the inlet port on the other side. On de-pressurisation, a reverse flow of the oxygen takes place until the pressure drop allows the sleeve to close around the valve flange.

#### Hinge mechanism

33. Travel of the pressure visor, either to the open or closed position, entails two separate movements by each hinge assembly. These are:—

(1) Rotation of the complete hinge to move the visor between the open and closed position.

(2) Movement of a crank mechanism which alters the radius of visor travel, i.e. :—

(a) On closing: reducing radius of operation and pulling the visor down on to its pressure seal.

(b) On opening: increasing radius of operation by throwing the visor forward to clear the pressure seal and shell casing.

#### Note ...

*These two movements are interlocked so that they can only occur in sequence. This is achieved by means of the ball interlock (para. 20).*

34. On raising the bar to lift the pressure visor to its open position, the bar travel rotates the centre spindle (to which it is pin-joined), and the rotation of the spindle (fig. 5) actuates the bevel gear and pinion which, in turn, rotates the cross shaft. The two cranks and the cam, which are pin-joined to the shaft, are also rotated. In rotating through an angle slightly in excess

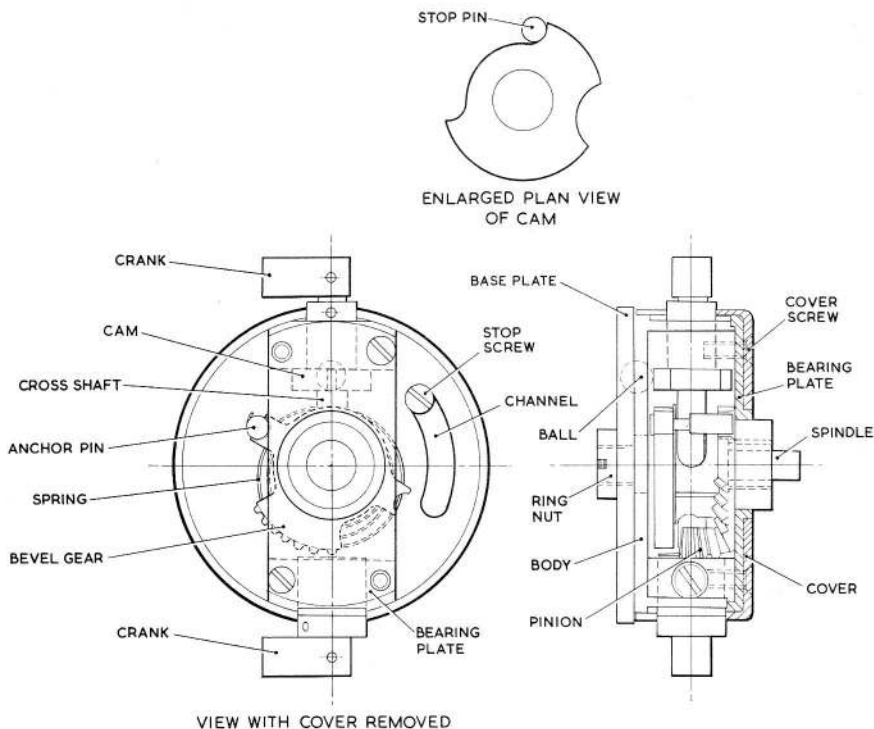

Fig. 5. Hinge mechanism

of 90 deg. the cranks move the pressure visor forward, away from the seal. When the cam is rotated to the end of its travel (abutting the stop pin) the cut-away section of the cam is aligned with the inter-locking ball and allows the ball to rise clear of the baseplate, thus disengaging the baseplate with the body. Further movement of the visor bar and centre spindle rotates the body over the baseplate. This action carries the visor upwards until its spring-loaded plungers lock behind the trigger of the release box assembly, the upward movement tightening both the bevel gear spring and the external spring attached to the hinge arm of the visor bar connection to the hinge. A stop screw limits

the body travel by abutting one end of the channel in the body, thus preventing over-riding.

35. On release of the pressure visor from its open position, whether manual or automatic, the bevel gear spring rotates the body until the stop screw hits the opposite end of the channel. At the same time, the ball is aligned with its baseplate housing and falls into it, releasing the cam and allowing further rotation of the cross shaft. The cranks are turned to pull the visor down on to the pressure seal. Further impetus for visor closing is provided by the external spring.

RESTRICTED

## SERVICING

36. Servicing should be completed in accordance with, and at the periods stipulated, in Vol. 4. The correct functioning of the helmet is vital, particularly in its use as an oxygen mask and for communication. Helmet servicing should be performed on a cloth-covered work bench.

### IMPORTANT

*No grease or oil (including hair oil) is to be allowed to enter the interior of the helmet, nor to contact the inside surface of the pressure visor or the vicinity of the oxygen tubes.*

### Lining

37. Each lining should be washed frequently in clean water to remove all traces of dirt and grease. Replacement linings are issued with each helmet and should always be readily available for use.

### Cleaning

38. In order to maintain a satisfactory standard of serviceability, the helmet should be sponged out with clean warm water, dried, and dusted inside with dusting powder regularly after use. Anti-misting of the pressure visor is attained chemically by an application of Lissapol N, the visor being removed from the helmet for this purpose. The pressure visor should not be scratched or otherwise damaged.

### Note ...

*Lissapol N should not come into contact with rubber components because of its injurious effect on rubber. It is also essential that all traces of Lissapol N are removed from the hands at cessation of the cleaning operation. Perspex or anti-dim polishes are not to be used for visor cleaning.*

39. No artificial heating is to be applied to assist in drying the interior of the helmet.

## TESTING

### IMPORTANT

*A pre-flight test of the helmet is to be made before every flight. It is dangerous to attempt this test*

*unless a pressure jerkin and anti-g suit are worn, connected and tested at the same time. Test schedules for the pressure jerkin and anti-g suit are detailed in Vol. 4. Nitrogen dilution tests should be made in accordance with local standing orders.*

### Visor arm torsion test

40. (1) Mount the helmet on the dummy head of the rig, clear lining creases as much as practicable, adjust helmet to obtain best possible fit and tighten straps.

(2) Attach a spring-balance to visor bar and apply load gently and evenly. Visor should drop when a load of from 5 to 7 lb. is applied.

(3) If, when visor drops, the load is not within the stated limits, remove sealant from screw heads in visor catch. Insert an Allen key into screw heads and tighten or loosen as necessary.

### Note ...

*Ensure that equal tension is applied to each screw and that the release pin is maintained in its central position in the visor catch.*

(4) When tension is correctly adjusted seal the screws with No. 6 Tensol cement.

### Helmet pressure test (fig. 6)

41. (1) Check contents of the cylinder on the test rig by opening the ON/OFF valve and referring to the contents gauge on the regulator.

(2) Connect the plug in the oxygen tube of the helmet to socket on oxygen tube of test rig, and nitrogen analyser connection on helmet to pressure gauge connection on test rig.

(3) Lightly pinch the nosepiece on the helmet and slowly open the valve on the regulator. The visor is to close when the back pressure has built up to 0.5 lb./in.<sup>2</sup> in the oxygen mask.

(4) Check that the visor locking arm is fully down.

**RESTRICTED**

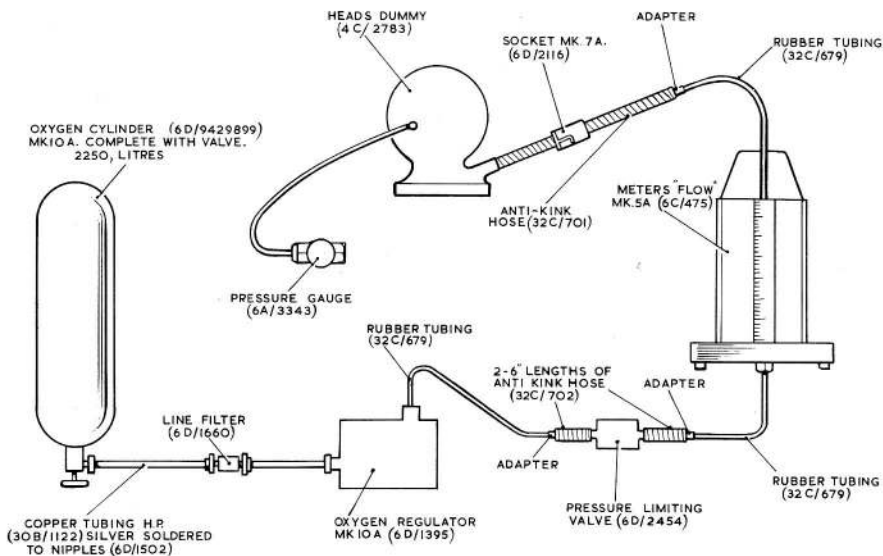

Fig. 6. Helmet pressure test rig

(5) Slowly open FLOW CONTROL valve until the pressure is 1.5 lb./in.<sup>2</sup>

(6) At this pressure, note the leak rate as registered by the rotameter on the test rig. The leak rate should not exceed 10 litres/min. If the leakage is between 5 and 10 litres/min., check the mouth door and visor for audible leaks. If an audible leak is detected from the mouth door, switch off the oxygen supply, check the rubber seal, renew as necessary and repeat the test. If there is no leak from the mouth door but an audible leak is detectable from the visor, ensure that the manual operating bar is fully down. If the leak persists but is within the range 5 to 10 litres/min., no further action need be taken as a loss of this magnitude is acceptable.

(7) If the leak rate is in excess of 10 litres/min. close the FLOW CONTROL valve and the ON/OFF valve. Allow all pressure to exhaust from the helmet, refit

the helmet to the dummy head and repeat the test. It is important to obtain the best possible fit by the helmet to the dummy head and to bear in mind that the helmet will probably seal better on its owner's head than on the dummy.

(8) If, on the second test, the leak rate is still unsatisfactory, then the helmet should be rejected and returned to the appropriate Maintenance Unit.

(9) If the test is satisfactory, remove the helmet from the dummy head, clean, de-mist and powder with dusting powder (Ref.No. 1A/01470).

#### REMOVAL AND ASSEMBLY

42. Removal and assembly operations for the majority of the component parts are straightforward. Linen thread and adhesive tape disturbed during removal of a component must be renewed when the component is refitted.

#### Removing the compensated breathing valve

43. Remove the valve in the following manner:-

- (1) Take out the three screws, retaining the oxygen tube cover to the shell casing, and slide the cover along the tube.
- (2) Sever and remove the linen thread from round the attachment flange of the pressure bladder and withdraw the valve.
- (3) Sever and remove the linen thread from round the outlet end of the oxygen delivery tube and withdraw the valve extension from inside the tube.

#### Installing the compensated breathing valve

44. Install the valve in the following manner:-

- (1) Insert the valve extension into the outlet end of the oxygen delivery hose, ensuring that the metal flange of the extension is correctly located in the first corrugation of the tube. Secure by binding with No. 18 linen thread (*waxed*).
- (2) Place the valve in the pressure bladder aperture and secure by binding with two turns of No. 18 linen thread (*waxed*).
- (3) Replace and secure the cover to the shell casing with three 6 B.A. screws and nuts.

#### Donning the helmet

45. (1) Ensure that both runs of the fastener are properly engaged in the slider and that the slider has freedom of movement.

(2) Hold the helmet in both hands by the neck. Insert the head, chin first, through the opening in the back of the helmet and pull on in an upwards and backwards direction. Settle the helmet comfortably on the head, making sure that the front edges of the silk lining are well behind the leading edges of the face seal, and that the under flexible edge of the oxygen mask is comfortable around the mouth and under the chin.

(3) Ensure that the earphones have not become displaced during the foregoing operation. If necessary, they can be made comfortable by inserting the hand between the ear and the bladder at each side to attain correct positioning.

(4) Close the sliding fastener, taking care that the slider is not pulled past the safety catch at the lower extremity of the shorter line of teeth. Tighten the adjusting straps just sufficiently to ensure that the oxygen mask is snug on the nose, under the chin and on the cheeks, and that the brow seal is tight on the forehead.

#### Removing the helmet

46. The helmet is removed in a few seconds by a smooth, natural action. A sharp pull upwards and forwards on the braided lanyard, which is fitted to the runner of the slide fastener, moves the slider past the safety catch at the lower extremity of the shorter line of teeth and the sliding fastener is disengaged. Continuation of the pull removes the helmet from the head.

47. After removal, the sliding fastener must be reset. Move the slider to the upper extremity of the longer line of teeth and engage it with the shorter line.

This file was downloaded  
from the RTFM Library.

Link: [www.scottbouch.com/rtfm](http://www.scottbouch.com/rtfm)

Please see site for usage terms,  
and more aircraft documents.

