

Chapter 1

JAVELIN F(AW) Mk. 1, 2, 4, 5, 6 AND T Mk. 3

LIST OF CONTENTS

	Para.		Para.
Composition of the assembly	1	Equipping the seat	12
Mk. 3J ejection seat	2	Strapping-in procedure	13
Mk. 3JT ejection seat	10	Emergencies	14
Connections to the aircraft	11	Leaving the aircraft after landing	15

LIST OF ILLUSTRATIONS

	Fig.		Fig.
The seat equipped (1)	1	Arrangement of drogue withdrawal and link lines	5
The seat equipped (2)	2	Arrangement of leg restraint cords	6
Arrangement of oxygen supply on seat Pre-Mod. 925	3	The seat occupied (1)	7
Arrangement of oxygen supply on seat Post Mod. 925	4	The seat occupied (2)	8

LIST OF APPENDICES

	App.
Flying clothing	1

COMPOSITION OF THE ASSEMBLY

1. The aircrew equipment assembly for each seat consists of the following items:--
Pre-Mod. E.S.925 (Mk. 1, 2, 4, 5 and 6 aircraft)
and Pre-Mod. E.S.2023 (T Mk. 3 aircraft)

Ejection seat	Mk. 3J or 3JT, as applicable
Safety harness	Type ZF
Parachute assembly	Back type Mk. 9
Personal survival pack	Type Q
Cushion	15A/729
Emergency oxygen set	Mk. 4A
Flying clothing	Refer to Appendix 1

Post Mod. E.S.925 and 2023

Ejection seat	Mk. 3J or 3JT, as applicable
Safety harness	Type ZF
Parachute assembly	Back type Mk. 9, incorporating Mod. Para. M 151
Personal survival pack	Type R
Cushion	27C/2428.
Emergency oxygen set	Mk. 7C, c/w upper oxygen tube assembly 6D/2124
Flying clothing	Refer to Appendix 1

RESTRICTED

Mk. 3J ejection seat

2. The seat is ejected from the aircraft by a cartridge operated gun and slides in a guide rail attached to the airframe structure. It incorporates a Type ZF safety harness, two firing handles, headrest cushion, leg restraint cords, parachute pack container and a seat pan which houses the personal survival pack. An emergency supply of oxygen is either carried in the seat pan (pre-Mod. E.S.925) or mounted on the seat beam (post Mod. E.S.925).

3. To prevent injury to the legs during ejection, the leg restraint cords are designed to ensure that the legs are drawn back to the seat pan and restrained there; this arrangement prevents the legs being blown apart by air blast.

4. The main firing handle projects from the front of the drogue container and has an integral face screen. The alternative firing handle is positioned inside the front wall of the seat pan and is intended for use only when circumstances, such as high G forces, prevent the use of the main handle.

5. Both firing handles are interconnected with the hood jettison mechanism for the particular cockpit. When either handle is pulled, the hood is jettisoned immediately and the seat is ejected one second later. A separate control handle is provided to allow the hood to be jettisoned without resorting to ejection.

6. Seat height is adjusted by a lever at the starboard side of the seat pan; a knob in the end of the lever must be depressed before the seat can be moved up or down. A safety harness 'go-forward' lever is mounted on the starboard panel of the seat pan; the lever is raised to disengage the harness lock and allow the occupant to bend forward in the cockpit without disconnecting the safety harness.

7. Fully automatic facilities are provided to separate the occupant from the seat after ejection and to release the parachute canopy from its pack after separation. A manual override control (a D-ring) is located on the parachute harness waistbelt to disconnect the automatic withdrawal device from the seat if the need arises to (a) make a manual bale-out from the aircraft or (b) make a manual separation from the seat after ejection.

8. As the seat is ejected, all connections to the aircraft are broken and the emergency oxygen supply is turned on automatically.

9. Information concerning the ejection seat will be found in A.P.4288, Vol. 1. The parachute assembly, safety harness and personal survival pack are described in A.P.1182A, Vol. 1 (2nd Edn.), A.P.1182B, Vol. 1 and 6 and A.P.1182C, Vol. 1, respectively.

Mk. 3JT ejection seat

10. This is basically a Mk. 3J seat modified to improve the forward view of the instructor who occupies the rear seat in T Mk. 3 aircraft. The barostatic release unit is located lower down the beam and a Type 3 drogue gun has been substituted for the Type 2; details of the seat are contained in A.P.4288, Vol. 1. The information in para. 2 of this chapter also applies, but Mod. E.S.2023 not 925 is the modification which decides the combination of the assembly.

Connections to the aircraft

11. With the seat installed in the aircraft, the following items are connected to the airframe:—

(1) Port side of seat:—

- (a) Static rod from the drogue gun.
- (b) Mic/Tel lead.
- (c) Anti-G suit air supply hose.

(2) Starboard side of seat:—

- (a) Static rod from barostatic time-release unit.
- (b) Static line from emergency oxygen cylinder operating head.
- (c) Main oxygen supply hose.

(3) Front of seat:—

- (a) Leg restraint cords.

(4) Top of seat:—

- (a) Hood jettison and time-delay unit operating cables.

EQUIPPING THE SEAT

12. The following procedure is to be adopted;

RESTRICTED

116

refer to fig. 1, 2, 3, 4 and 5, as applicable, noting that Mod. E.S.2023 is to be read into the illustration title in addition to Mod. 925:-

- (1) Ensure that the seat has been made safe for servicing in accordance with current instructions.

Pre-Mod. E.S.925 and 2023 seats

- (2) Arrange the safety harness shoulder straps over the back of the parachute pack container and ensure that the lap straps and leg restraint cords are clear of the seat pan.
- (3) Place the Type Q personal survival pack in the seat with the lowering line satchel to the rear and the end of the line emerging over the port side of the seat pan. Ensure that the lowering line passes OVER the anti-G air supply hose and that the pack is located well back in the seat pan.
- (4) Check that the lower edge of the apron is clipped to the lower extension of the parachute pack container.
- (5) Tension the apron against the clips and place the parachute pack in the container; ensure that the lower edge of the pack is located behind the corner plates of the container. Before pressing the pack fully home, connect the two components of the withdrawal line coupling.
- (6) After locating the parachute pack in the container, fit the pack restraining straps into the clips at each side of the container.
- (7) Arrange the parachute harness so that the cushion containing the emergency oxygen cylinder rests between the front of the personal survival pack and the front wall of the seat pan; the operating head of the cylinder is to point in the direction of the starboard side of the seat and the cushion must not obstruct the alternative firing handle.

- (8) Pass the emergency oxygen supply tube through both tunnels and the personal survival pack D-ring at the right-hand side of the parachute harness; pass the operating cable and housing through the D-ring only.
- (9) Connect the personal survival pack side quick-release couplings to the parachute harness and tuck away the ends of the straps down the sides of the seat pan.
- (10) Fit the parachute harness sticker straps into the spring clips on the sides of the seat pan.
- (11) Pass the emergency oxygen cylinder operating cable OVER the safety harness automatic release cable and connect the knurled and screwed union on the cable to the corresponding union on the anchor section of the static line. Engage the end fitting of the cable housing, with the anchor socket and connect the anchor hook to the static line/manual operating cable.
- (12) Stow the harness on the clips provided in the cockpit.
- (13) Locate the leg loop of the parachute harness between the starboard side of the alternative firing handle and the seat cushion.
- (14) Remove the safety pins from the ejection gun, hood jettison sear and time delay trip lever; fit the appropriate pin through the main firing handle safety strap.

Post Mod. E.S.925 and 2023 seats

- (15) After sub-para. (1), fit the emergency oxygen cylinder into the clamping brackets on the seat beam; ensure that the supply tube faces forward.
- (16) Proceed as in sub-para. (2) to (6), but note that the Type R pack is used instead of the Type Q and that the

RESTRICTED

lowering line is against the port side wall of the seat pan.

- (17) Proceed as in sub-para. (9) to (14) and connect the upper oxygen tube assembly to the emergency oxygen supply tube.

STRAPPING-IN PROCEDURE

13. The following procedure is to be adopted, reference being made to fig. 6, 7 and 8 as necessary; it is assumed that leg restraint garters have been fitted prior to leaving the dressing room:—

- (1) Check that the safety pins are fitted through the safety straps of the main and alternative firing handles.
- (2) Remove and retain the safety pin from the emergency oxygen cylinder operating head.
- (3) Sit in the seat and adjust the height; ideally the head rests in the centre of the headrest cushion.
- (4) Connect the personal survival pack lowering line to the life jacket; ensure that the line does not pass through the parachute harness straps.
- (5) Connect the anti-G air supply hose to the suit; ensure that the hose passes OVER the personal survival pack lowering line.
- (6) Fasten and tighten the parachute harness. Ensure that the position of the quick-release fitting is as high as possible (over the solar plexus), that the shoulder straps pass UNDER the life jacket stole and that the leg loop does not pass through the alternative firing handle. Fit the safety pin clip behind the quick-release fitting disc knob.
- (7) Fasten, but do not tighten, the safety harness lap straps.
- (8) Pass the starboard leg restraint cord through the left leg garter D-ring and under the port safety harness lap strap. Pass the port shoulder strap lug through the loop at the end of the leg restraint cord and insert the lug in the quick-release fitting.
- (9) Pass the port leg restraint cord through the right leg garter D-ring and under the starboard safety harness lap strap. Pass the starboard shoulder strap lug through the loop at the end of the leg restraint cord and insert the lug in the quick-release fitting.
- (10) Tighten the safety harness lap straps and ensure that the quick-release fitting is well down in the lap (below the parachute harness fitting.)
- (11) Adjust and tighten the safety harness shoulder straps. Do not overtighten these straps; they are intended to restrain forward movement of the shoulders, not to compress the body down into the seat.
- (12) Adjust the leg restraint cords in the snubbing units until the desired freedom of leg movement is obtained; the remaining slack in the cords is to be between the snubbing units and the cockpit floor.
- (13) Put on the flying and protective helmets, fasten the chin straps and connect the Mic/Tel lead.
- (14) Connect the oxygen mask to the main oxygen supply hose and adjust the hose in its retaining clip on the starboard lap strap of the safety harness to allow full head movement.
- (15) Pass the emergency oxygen supply tube, or upper tube assembly, as appropriate, under the safety harness starboard shoulder strap and connect it to the oxygen mask tube assembly.
- (16) Connect the oxygen mask tube assembly locating chain to its D-ring anchorage on the life jacket.
- (17) Remove the safety pin from the alternative firing handle safety strap and hand it to the ground crew member. The ground crew member removes the safety

pin from the main firing handle safety strap and from the hood jettison handle and stows all three pins in their appropriate stowages.

Note . . .

In the absence of a ground crew member, the pins are to be removed and placed in their stowages by the seat occupant before strapping in.

EMERGENCIES

14. Instructions for dealing with emergencies are contained in A.P.4491A and D, B, C, E, F - P.N. as appropriate to the mark of aircraft.

LEAVING THE AIRCRAFT AFTER LANDING

15. The following procedure is to be adopted:-

- (1) The ground crew member removes the safety pins from their stowages, hands the pin for the alternative firing handle to the seat occupant and fits the pins to the main firing handle and hood jettison handle. The seat occupant fits the alternative firing handle safety pin.

Note . . .

In the absence of a ground crew member, the seat occupant is to fit all three safety pins before leaving the aircraft.

- (2) Disconnect the main and emergency oxygen supply from the oxygen mask tube assembly.
- (3) Disconnect the Mic/Tel lead.
- (4) Release the safety harness and free the leg restraint cords.
- (5) Remove the safety pin clip from the parachute harness quick-release fitting, release the harness and return the fitting to the locked position.
- (6) Disconnect the anti-G air supply hose and fit the blanking plug into the hose.
- (7) Disconnect the personal survival pack lowering line from the life jacket, arrange the line to drape over the side of the seat pan.
- (8) Vacate the seat.

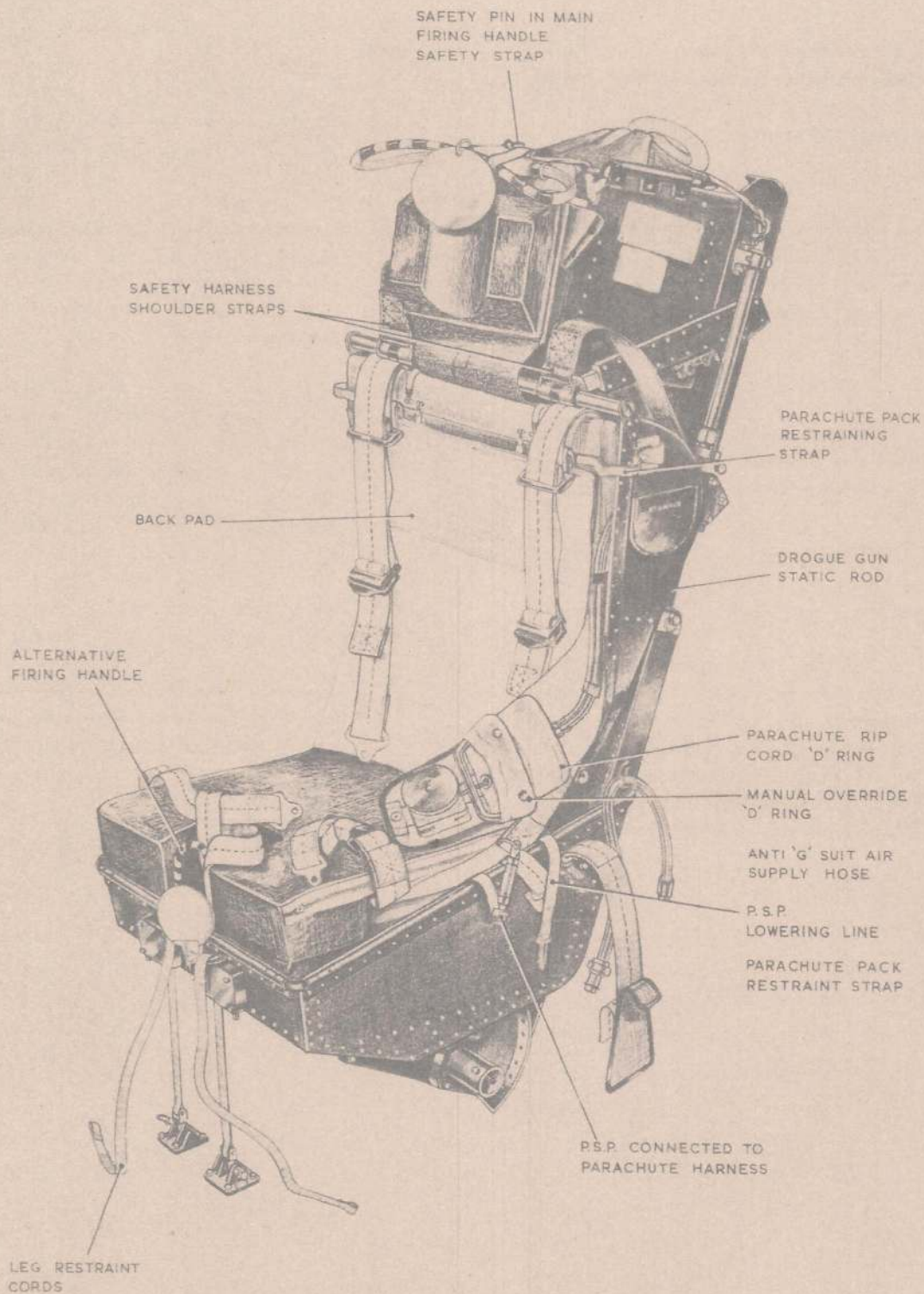

Type ZF Harness shown

Fig. 1. The seat equipped (1)

RESTRICTED

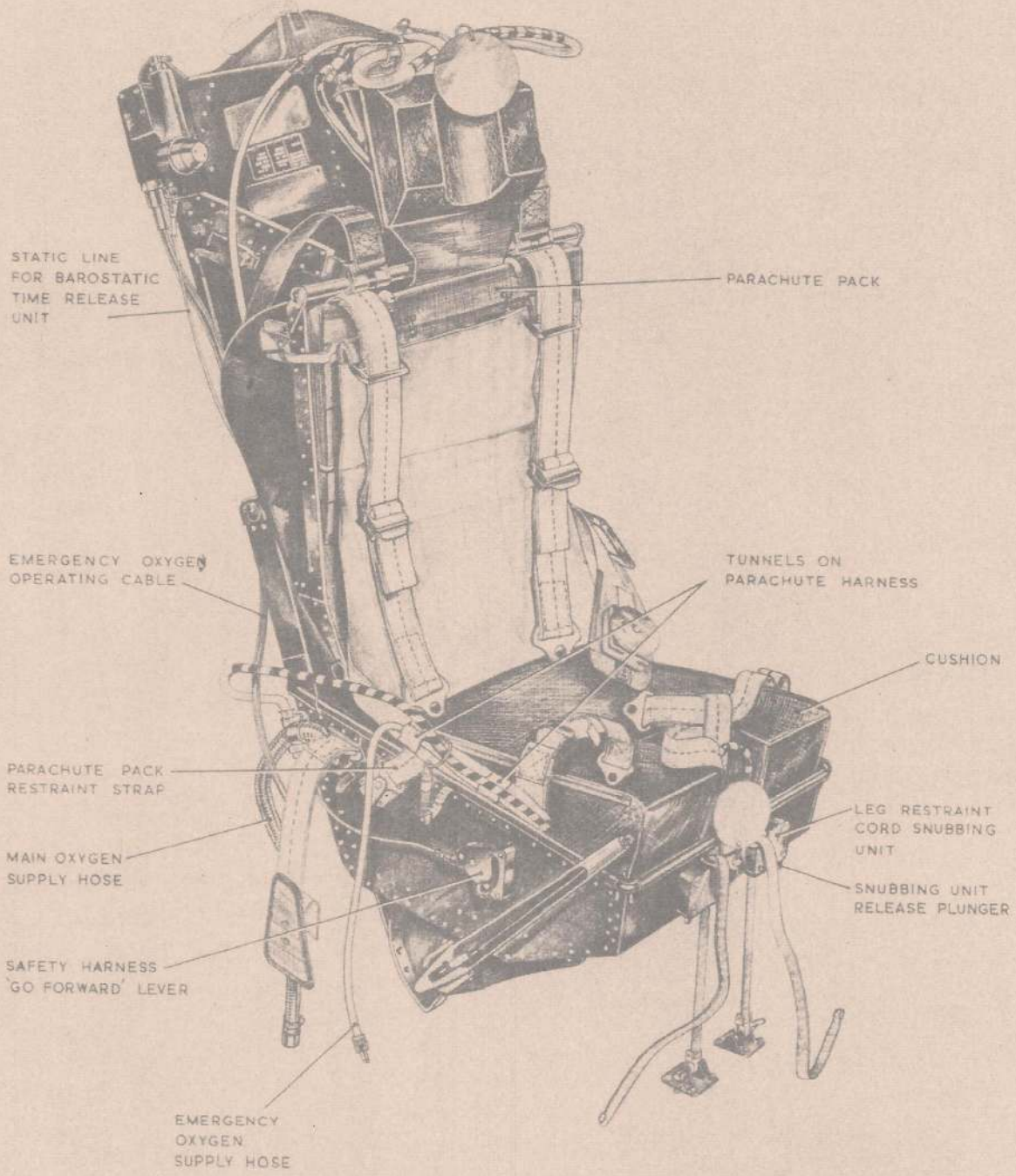

Type 2F Harness shown

Fig. 2. The seat equipped (2)

RESTRICTED

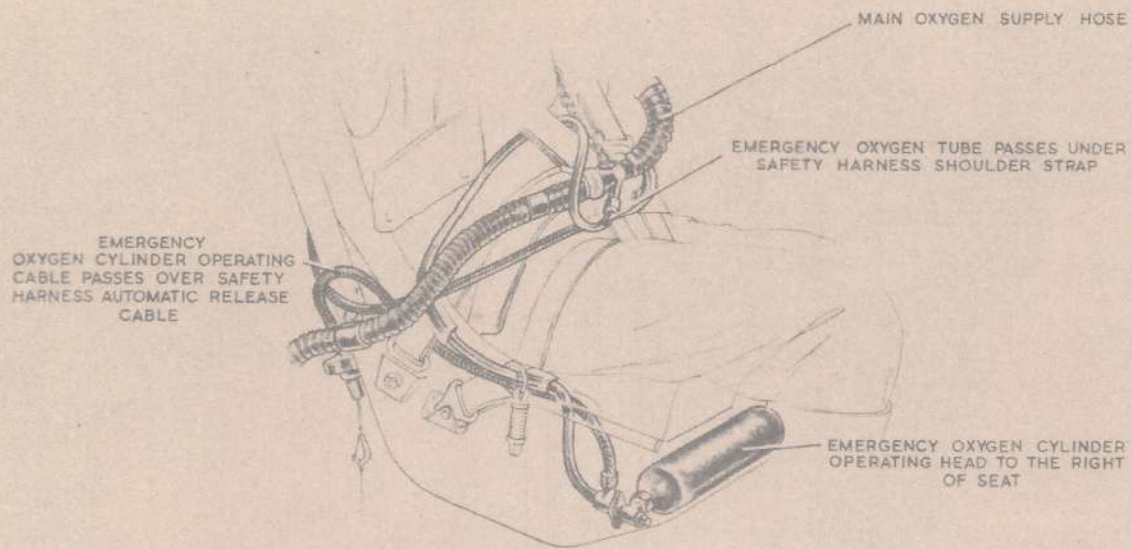

Fig. 3. Arrangement of oxygen supply on seat Pre-Mod. 925

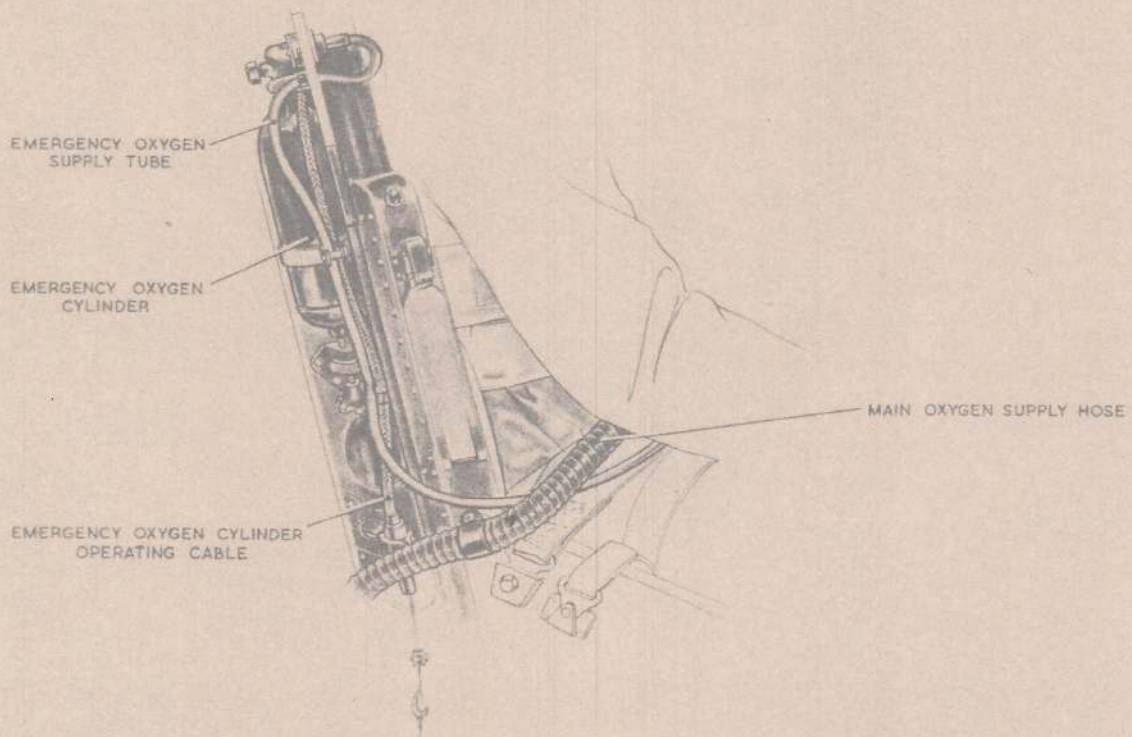
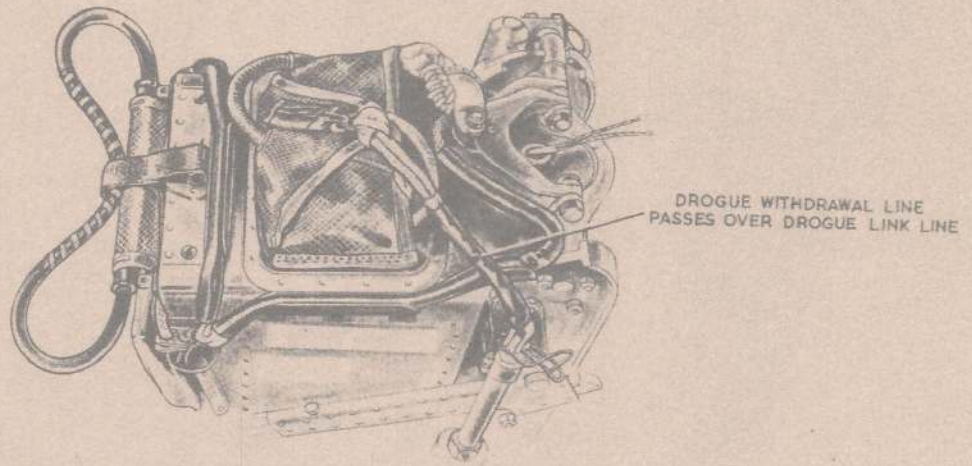

Fig. 4. Arrangement of oxygen supply on seat Post Mod. 925

RESTRICTED

172



DROGUE WITHDRAWAL LINE
PASSES OVER DROGUE LINK LINE

Fig. 5. Arrangement of drogue withdrawal and link lines

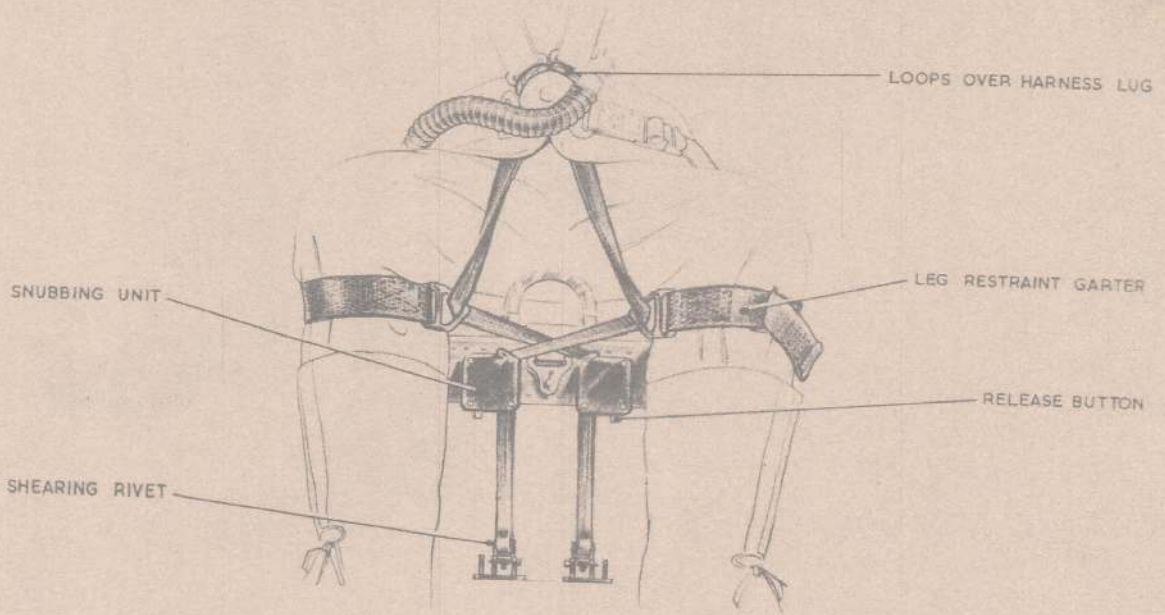

LOOPS OVER HARNESS LUG

SNUBBING UNIT

LEG RESTRAINT GARTER

RELEASE BUTTON

SHEARING RIVET

Fig. 6. Arrangement of leg restraint cards

RESTRICTED

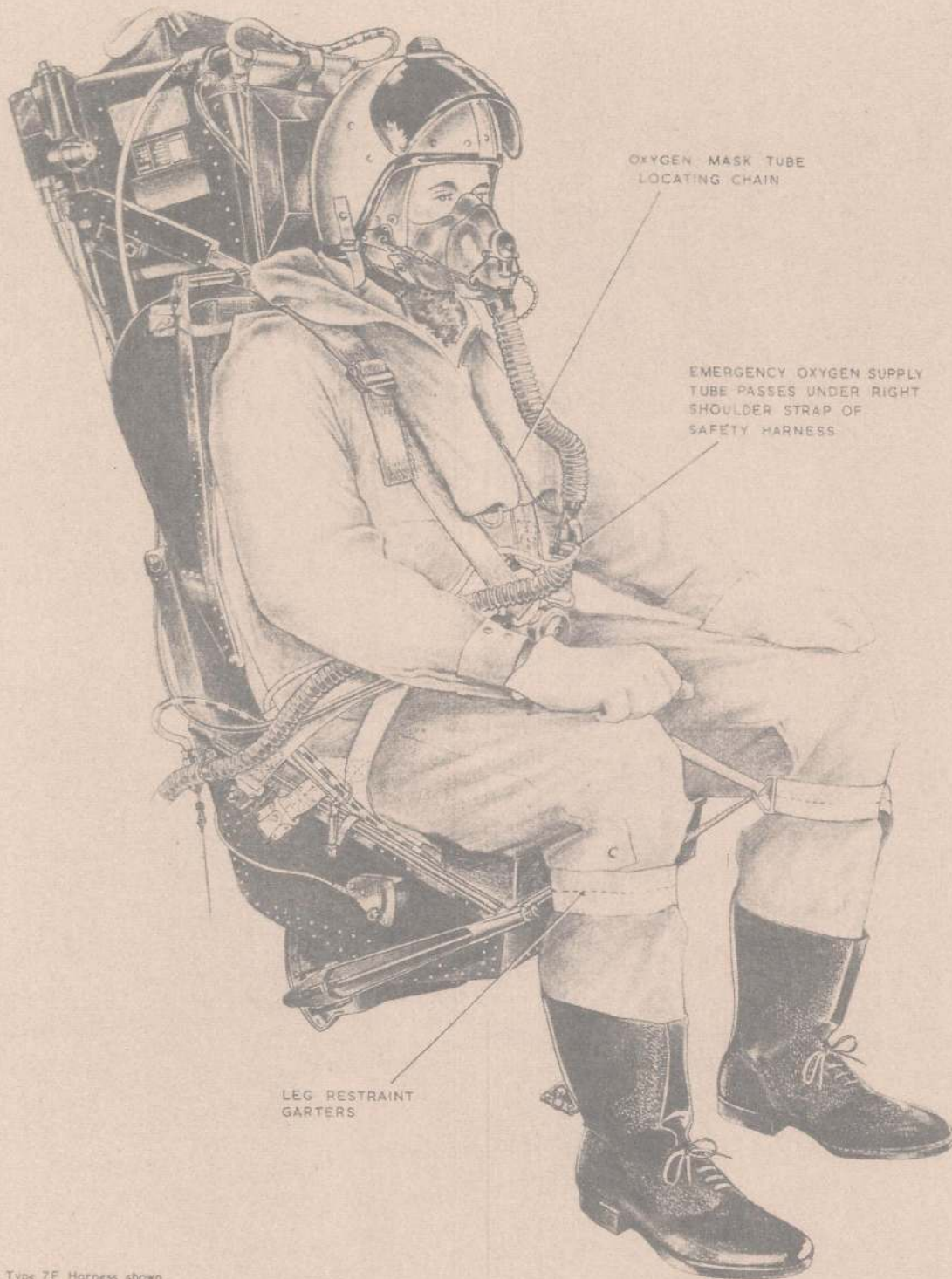

Type ZF Harness shown

Fig. 7. The seat occupied (1)

RESTRICTED

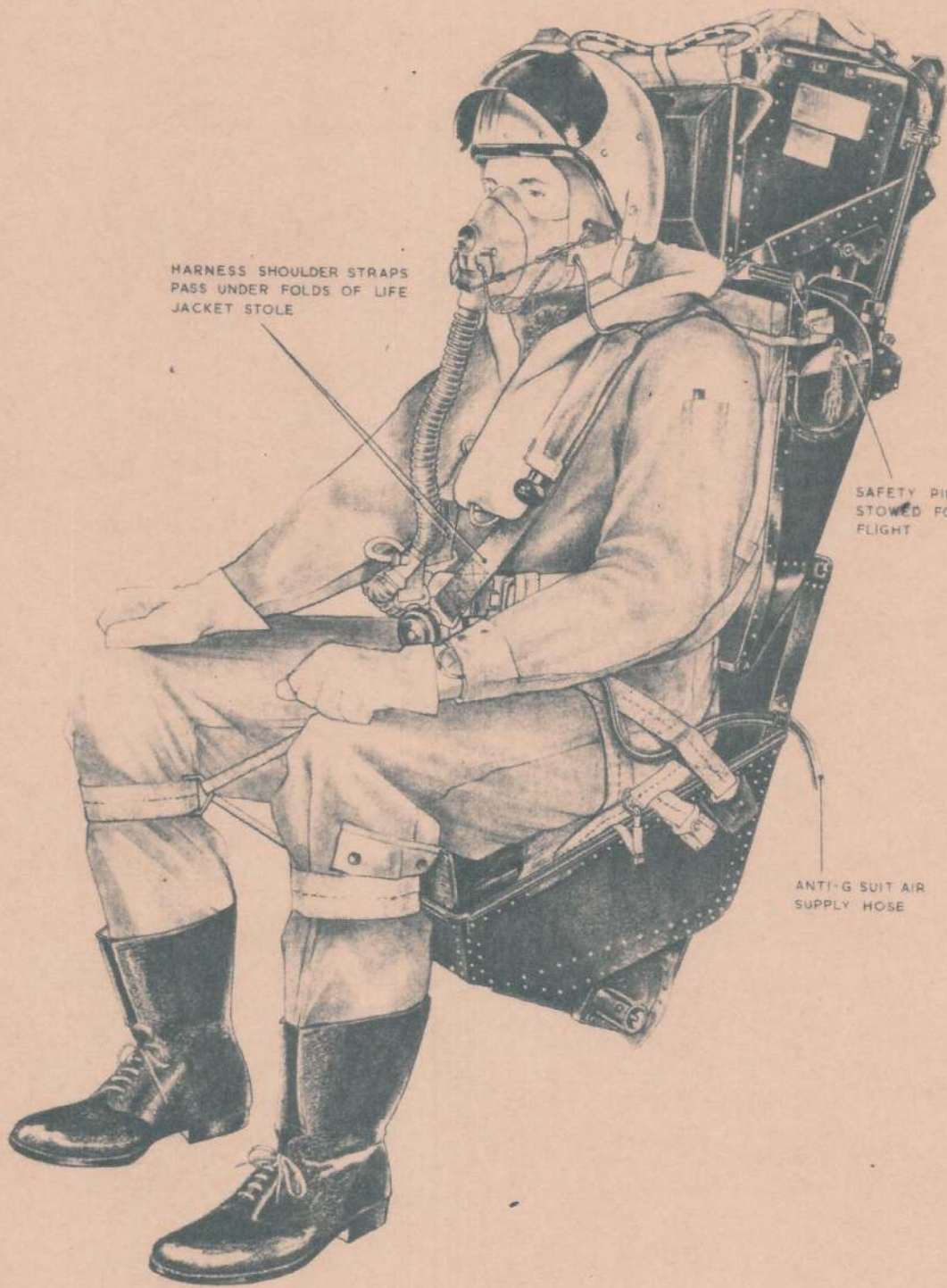

Type ZF Harness shown

Fig. 8. The seat occupied (2)

RESTRICTED



This file was downloaded
from the RTFM Library.

Link: www.scottbouch.com/rtfm

Please see site for usage terms,
and more aircraft documents.