

APPENDIX 2

NAVIGATOR'S STATION
(Type 4QS Mk. 2 seat)

LIST OF CONTENTS

	<i>Para.</i>		<i>Para.</i>
<i>Introduction</i>	1	<i>Guillotine</i>	17
<i>Description</i>		<i>Personal survival pack, Type R</i>	18
<i>Composition of the assembly</i>	3	<i>Emergency oxygen</i>	20
<i>Firing handles</i>	5	<i>Sequence of events during ejection</i>	23
<i>Personal equipment connector</i>	7	<i>Equipping the seat</i>	
<i>Leg restraint system</i>	10	<i>Connections to the aircraft</i>	24
<i>Seat raising gear</i>	11	<i>Equipping the seat</i>	25
<i>Combined harness</i>	12	<i>Strapping-in procedure</i>	26
<i>Negative-G restraint strap</i>	14	<i>Emergencies</i>	27
<i>Automatic equipment</i>	15	<i>Leaving the aircraft after landing</i>	28
<i>Manual separation</i>	16		

LIST OF ILLUSTRATIONS

	<i>Fig.</i>		<i>Fig.</i>
<i>Demand emergency oxygen system</i>	1	<i>The seat equipped (port)</i>	7
<i>Attachment of parachute restraining straps to paddle spreaders</i>	2	<i>The seat equipped (starboard)</i>	8
<i>Insertion of top harness lock</i>	3	<i>Arrangement of leg restraint cords and harness straps</i>	9
<i>Arrangement on port side of drogue container</i>	4	<i>The seat occupied (port)</i>	10
<i>Fitting negative-G strap</i>	5	<i>The seat occupied (starboard)</i>	11
<i>Negative-G strap fitted</i>	6		

Introduction

1. An ejection seat Type 4 QS Mk. 2 is being introduced by aircraft modifications to the navigator's station in the Canberra PR. Mk. 9. When aircraft have been modified, information in this appendix dealing with the aircrew equipment assembly is to be employed.

2. The principal item of the A.E.A. is the ejection seat, to which the other equipment may be regarded as ancillary. This appendix gives a general description of the complete assembly, the method of equipping the seat before use, the strapping-in procedure and how to leave the seat after landing.

DESCRIPTION

Composition of the assembly

3. The navigator's aircrew equipment assembly consists of the following items :-

Ejection seat	Type 4QS Mk. 2
Parachute assembly (incorporating combined harness)	Back Type Mk. 45
Personal survival pack	Type R

RESTRICTED

Emergency oxygen set Cylinder, demand emergency oxygen/operating head assembly Mk. 3
(Ref. No. 6D/2752)

Regulator, demand emergency oxygen Mk. 1
(Ref. No. 6D/2285)

Flying clothing Refer to Appendix 1

4. The Type 4QS Mk. 2 seat is ejected from the aircraft by a cartridge-operated gun and during ejection slides on a guide rail attached to the airframe structure.

Firing handles

5. The seat is fitted with two firing handles. One, which has an integral face screen, projects from the front of the drogue container, and is referred to as the face screen firing handle. The other, referred to as the seat pan firing handle, is located at the front of the seat pan and is intended for use when the occupant is unable to reach the face screen firing handle, e.g. when subjected to high G forces.

6. There is no connection to a canopy jettison mechanism on the seat and the use of either of the firing handles operates the ejection seat immediately without any delay. Ejection is through a frangible hatch in the roof of the nose compartment. The frangible hatch is attached at the rear by reaction hinges which come apart when the hatch has been opened to a predetermined angle. It is held closed by shoot bolts at the sides, operated by a lever close to the forward starboard corner of the hatch. The front edge of the hatch is fitted with slotted links (through which retaining pins pass) so that when the side bolts are freed, the hatch may open slightly to an angle at which the hinges remain secure. The retaining pins may be withdrawn by a second handle, to jettison or free the hatch entirely. The opening features of the hatch are useful for servicing purposes and may sometimes be found helpful in assisting the navigator to strap-in; but owing to uncertainties about the hatch behaviour in the air or in a crash landing, it is not recommended that the hatch be jettisoned in flight. Emergency escape must be by ejecting through the hatch IN THE FULLY CLOSED POSITION ONLY.

Personal equipment connector

7. The personal equipment connector (referred to as the P.E.C.) is fitted to the starboard side

panel of the seat pan. It enables the main oxygen, emergency oxygen, air-ventilated suit, and Mic/tel leads to be connected or disconnected in one action. It is also linked to the leg restraint cords (para. 10) so that the legs are released when the P.E.C. is disconnected. The connector comprises three components :-

- (1) *Aircraft component.* Connected to the cockpit structure by a telescopic static rod, and to the personal supply systems in the aircraft.
- (2) *Seat component.* Bolted to the seat pan, and connected to the emergency oxygen (para. 20). This component has an operating linkage from the main barostatic time-release unit and another linkage to the leg restraint cords.
- (3) *Personal component.* Attached to the flying clothing.

8. As the seat ascends the guide rail during ejection, the aircraft component of the P.E.C. is detached from the seat component when the static rod becomes fully extended, thus severing and sealing off the connections between the seat and the aircraft. At the same time, the emergency oxygen supply is turned on automatically. Later, when the harness is released from the seat, the personal component is also automatically detached from the seat component.

9. A full description of the P.E.C. will be found in Sect. 1, Chap. 5. The type of P.E.C. fitted is the 'full pressure-suit' variant. This has three gas passages vertically through the three components; as in the 'Fighter' type, the foremost passage is not used at present, the central passage is for the air ventilated suit supply and the rear passage for oxygen (the anti-g suit is connected into the oxygen line between the P.E.C. and the jerkin).

Leg restraint system

10. Leg restraint cords are provided to ensure that the legs are drawn back and held close to the seat pan during and after ejection. The cords pass through snubbing units below the front of the seat pan and are then attached to the aircraft floor with shear rivets. The snubbing units allow the cords to pass freely downwards through the unit, but prevent the cords passing upwards except when released by the spring-loaded toggle at the front of each unit. An intercon-

RESTRICTED

nection between the taper plug assemblies on the front of the seat pan and the P.E.C. release the leg restraint cords as the personal component of the P.E.C. is disconnected.

Seat raising gear

11. The seat raising gear is operated by an electric actuator controlled from a switch on the starboard side of the seat pan. Instructions limiting the number of actuations which may be performed within a specified time (owing to the danger of overheating) are stated on a warning plate on the seat. This does not restrict normal use but is to be kept in mind if repeated seat movement is involved during testing.

Combined harness

12. Provision is made on the seat for attachment of the combined harness of the parachute assembly. The harness is attached at three points in the back of the seat; one centrally just below the parachute support bracket, known as the top harness lock and one on each side at the bottom just above the floor level of the seat pan known as the bottom harness locks. These three anchorages are released automatically during the normal ejection sequence by the operation of a barostatic time-release unit; the personal component of the P.E.C., the leg restraint cords, and the parachute restraining straps, are also released simultaneously.

13. The upper anchorage of the harness embodies the 'go-forward' spring roller mechanism which permits the occupant to lean forward when required. This mechanism is controlled by a three-position spring-loaded lever at the front of the port side of the seat pan. If the lever is pushed fully forward and then released to the centre position, the occupant can lean forwards and back at will. Movement of the lever to the rear position brings the snubbing unit in the top harness lock into action, preventing further movement forward and automatically locking in the rearward position as the occupant leans back. In the event of a crash landing or an ejection occurring whilst the lever is in the centre position, an automatic inertia device brings the snubber into action to prevent the occupant being thrown forward.

Negative-G restraint strap

14. A strap to restrain the occupant when subjected to negative-G forces, is fitted. The strap passes through brackets in the floor of the seat pan; the rear ends are attached to the bottom harness lock lugs and the forward ends attached to the harness lap strap lugs which are retained in the quick-release fitting. Means are provided for tensioning the strap during the strapping-in procedure.

Automatic equipment

15. Fully automatic facilities are provided to withdraw the parachute canopy and separate the occupant from the seat after ejection. The automatic equipment includes a drogue gun and drogues and a barostatic time-release unit. The drogue gun is operated by a static rod which initiates a time delay of $\frac{1}{2}$ sec. and then fires out a heavy bullet to open the drogue container and extract the drogues, which develop and stabilise the seat. The barostatic time-release unit is also initiated by another static rod. If the altitude is lower than 10,000 ft. and the deceleration of the seat is below a value corresponding to a safe parachute opening speed, the time-delay mechanism operates after $1\frac{1}{4}$ sec. After this delay the barostat plunger is pressed down by a strong spring and (a) releases the drogues from the container so that they transfer the pull to the apex of the parachute (to which they are attached), (b) release the rear anchorage of the face screen and the parachute pack restraining straps, (c) release the harness from the seat, (d) operates the P.E.C. and (e) release the leg restraint cords; the reader is, however, referred to para. 23 (7).

Manual separation

16. In the event of failure of the automatic facilities, a manual separation handle is fitted on the port side of the seat, which when operated, releases the occupant from the seat, simultaneously releasing the P.E.C. personal component, the leg restraint cords and the parachute restraining straps. In the event of failure to eject, the same procedure inside the cockpit may enable a manual bale-out to be made in favourable circumstances. The manual separation handle is provided with a thumb-operated trigger which must be depressed before the handle can be operated.

RESTRICTED

Guillotine

17. As the occupant separates from the seat after operation of the manual separation handle, a static line attached to the rear of the parachute pack withdraws the sear from the guillotine gun attached to the port side of the drogue container. This causes the guillotine to fire and sever the parachute withdrawal line, thus separating the seat structure from the parachute. The parachute is then deployed by pulling the D handle of the parachute rip cord attached to the waistband of the harness.

Personal survival pack, Type R

18. The personal survival pack is housed in the seat pan and serves as a cushion. It is attached to the lower harness straps by two quick-release couplings at the sides and to the life jacket or jerkin by the lowering line stowed in the port side flap on the pack. The harness attachments are connected when the safety equipment is installed in the seat and the lowering line by the occupant when strapping-in. The lowering line, being attached to the clothing, enables the pack side attachments to be released from the harness during a parachute descent so that the pack falls and hangs 15 ft. below the body. On alighting this enables the harness to be discarded immediately without loss of the pack.

19. A thin cushion is provided with the Type R pack to cover the underleg straps of the harness both in normal use and during parachute development; it is attached to the harness by press studs.

Emergency oxygen

20. The emergency oxygen system (fig. 1) is a 'demand' type consisting of an emergency oxygen cylinder and operating head assembly mounted on the rear of the seat pan, connected to a demand regulator mounted on the starboard side of the seat pan. From the demand regulator, the oxygen is fed to the rear end of the seat component of the P.E.C. The supply from the cylinder to the regulator is turned on automatically during ejection by a spring loaded trigger attached to a cross beam mounted on the rear face of the ejection gun, which engages the operating lever on the operating head of the oxygen cylinder during ejection. Also attached to the operating lever is a cable, which is carried in a conduit routed down the back and under the seat, and terminated in a yellow and black striped knob situated on the

starboard side of the forward face of the seat pan. This knob enables the emergency oxygen cylinder to be turned on during normal flight in the event of a failure of the main oxygen supply in the aircraft. A gauge fitted to the top of the cylinder enables the state of charge to be checked and the cylinder can be re-charged in situ through a re-charging valve on the operating head.

21. The demand type of emergency oxygen set is capable of meeting both pressure jerkin inflation and breathing requirements of the seat occupant in the event of failure of the main supply or when abandoning the aircraft. Detail information on the emergency oxygen cylinder and operating head assembly, and the demand emergency oxygen regulator, is contained in A.P.1275G, Vol. 1, Sect. 3, Chapters 10 and 11 respectively.

22. Information concerning the Type 4QS Mk. 2 ejection seat will be found in A.P.4288D, Vol. 1; the parachute assembly is dealt with in A.P.1182A, Vol. 1, and the personal survival pack in A.P.1182C, Vol. 1. Information concerning flying clothing will be found in App. 1 to this chapter, together with information on dressing and testing.

Sequence of events during ejection

23. When the firing handle is pulled, the seat ejects through the frangible hatch without any delay, and as the seat ascends the guide rail, the following sequence occurs :-

- (1) The leg restraint cords tighten until the rivets shear in the dead-eyes securing the cords to the floor.
- (2) The time-delay mechanism for the drogue gun is actuated, the gun being fired after $\frac{1}{2}$ second.
- (3) The time-delay mechanism for the barostatic time-release unit is tripped. The delay is variable, depending upon aircraft height and speed at the time of ejection.
- (4) The aircraft component of the personal equipment connector is separated from the seat component, disconnecting the oxygen and A.V.S. hoses and the Mic/Tel lead between the aircraft and the seat.

RESTRICTED

- (5) The emergency oxygen supply is turned on.
- (6) After $\frac{1}{2}$ second the drogue gun fires and the two drogues stabilize the seat. If the ejection occurs at high altitude the seat will eventually fall nearly vertical with the occupant restrained by his combined harness from falling forwards. At low altitudes there may not be time for the seat to attain the near vertical position. During this phase the occupant will be breathing emergency oxygen from the demand emergency oxygen set carried on the seat.
- (7) After an appropriate delay the occupant is released from the seat and his parachute canopy opens automatically. At the same time the personal component of the P.E.C. is released from the seat component, detaching the personal services from the seat and enabling ambient air to be inhaled. At moderate aircraft speeds and heights, the delay is $1\frac{1}{4}$ seconds after ejection. At high altitude the $1\frac{1}{4}$ second delay does not start until the seat has descended below 10,000 ft. At high speeds, at 10,000 ft. or below, delay does not start until the seat has decelerated to a safe speed for the parachute canopy to deploy.

EQUIPPING THE SEAT

Connections to the aircraft

24. When the seat is installed in the aircraft and is properly equipped, the following items are connected to the aircraft:—

- (1) *Port side of seat:—*
 - (a) Static rod to drogue gun.
- (2) *Starboard side of seat:—*
 - (a) Static rod to barostatic time-release unit.
 - (b) The aircraft component of the P.E.C. is locked to the underside of the seat component. (The aircraft component has a static rod to the aircraft structure and an oxygen supply hose, an A.V.S. supply hose and a Mic/Tel

lead from the appropriate systems; normally, these will already be connected).

(3) *Underneath the seat:—*

- (a) Leg restraint cords.

Equipping the seat

25. The following procedure is to be used when installing the equipment in the seat; refer to fig. 1 to 6 for detail as necessary:—

- (1) Ensure that the seat has been made safe for servicing in accordance with current instructions.
- (2) The demand emergency oxygen set (fig. 1) must be fitted before the seat and the ejection gun assembly are installed in the aircraft. Detailed instructions for fitting the demand emergency oxygen set are contained in A.P.4288D, Vol. 1.
- (3) Open the paddle spreaders situated in front of the top harness lock, and pass the 'O' rings of the two parachute restraining straps over the paddle spreaders (one over each spreader). Ensure that each 'O' ring is pushed well back towards the pivot end of its paddle spreader, and close the paddle spreaders inwards toward each other as far as they will go (fig. 2).
- (4) Place the parachute pack in the parachute container, guiding the static line for the guillotine through its aperture in the back plate; push the pack well into the container so that it is supported on the support bracket beneath the arch of the pack. Ensure that the harness straps are not twisted.
- (5) Ensure that the manual separation handle is in the locked position, i.e. fully down and with the thumb trigger engaged.
- (6) Push the harness 'go forward' lever fully forward, release it to its centre position, and pull out the webbing strap from under the parachute support bracket; hold it against the spring tension.

RESTRICTED

- (7) Pass the webbing strap downwards through the 'D' shackle attached to the harness shoulder straps and insert the lug fitted to the end of the webbing strap between the inner extremities of the paddle spreaders and into the harness lock in the back of the seat (*fig. 3*). Push the lug in until it locks into position; it may be necessary to partially depress the harness release lever, situated beneath the barostatic time release unit, to facilitate the insertion of the lug. Check that it has locked correctly by pulling on the webbing strap, then allow the strap to wind back.
- (8) Connect the two halves of the parachute withdrawal line/link line coupling. Open the yellow gate on the top of the guillotine and route the parachute withdrawal line through the aperture on the guillotine. Close the yellow gate and ensure that it correctly retains the parachute withdrawal line (*fig. 4*).
- (9) Draw the free ends of the parachute restraining straps forwards through the arch of the parachute pack, over the pack and towards the rear of the seat on either side of the drogue container.
- (10) Pass the port restraining strap over the parachute withdrawal line and insert its end through the buckle on the short strap on the port side of the drogue container from the outside inwards. Ensure that the drogue link line which is connected to the parachute withdrawal line is routed OUTSIDE the short strap as shown in *fig. 4*.
- (11) Insert the end of the starboard restraining strap through the buckle on the short strap on the starboard side of the drogue container from the outside inwards.
- (12) Position the wedge pad on the top of the parachute pack between the pack and the drogue container. Pass the ends of the parachute restraining straps through the buckles on each side of the wedge pad so that the ends emerge on the outside of the buckles.
- (13) Work the straps back and forth in the self-locking buckles on the wedge pad until the parachute pack and wedge pad are strapped tightly to the seat. Neatly stow the free ends between the drogue container and the strap (*fig. 4*).
- (14) Check that the drogue withdrawal line has been routed OVER the link line (*fig. 4*).
- (15) Attach the guillotine static line to the sear of the guillotine gun (*fig. 4*).
- (16) Fit the negative-g restraining strap as follows:— (*fig. 5 and 6*).
 - (a) Thread the white straps through the front bracket on the floor of the seat pan from front to rear. The white straps are marked PORT and STARBOARD; it is essential that they are so positioned to ensure correct installation.
 - (b) Pass the straps rearwards, and thread each strap through its respective rear bracket on the floor of the seat pan.
 - (c) Engage the looped end of each strap over its respective bottom lock harness lug and insert the lugs into their respective bottom locks. It may be necessary to partially depress the harness release lever beneath the barostatic time release unit to facilitate insertion of the lugs. Check that they have locked correctly by pulling on the lugs (*fig. 5*).
 - (d) Pull the negative-g strap forward through the anchor bracket to take up the slack and drape the Y-piece over the top of the seat pan firing handle.
- (17) Clear the seat pan. Place the survival pack in position, lowering line to port. Ensure that the transverse seat strap of the harness crosses OVER THE TOP of the pack at the back.
- (18) Connect the quick-release couplings on each side of the survival pack, to the combined harness.

RESTRICTED

- (19) Insert the harness sticker strap lugs into the clips on the inside of the seat pan; ensure that the sticker straps pass outside the personal survival pack quick-release couplings.
- (20) Arrange the harness and auxiliary cushion on the personal survival pack, pass the leg loops of the harness through the slot in the centre of the cushion, and secure the cushion to the seat strap of the harness with the press fasteners provided. Ensure that no straps are twisted; extend the lap and shoulder straps to their full extent (*fig. 7 and 8*).
- (21) Remove and retain the safety pin from the emergency oxygen cylinder operating head.
- (22) After equipping the seat restore it to the 'safe for parking' condition in accordance with current instructions.

STRAPPING-IN PROCEDURE

26. The strapping-in procedure is as follows, refer to *fig. 9 to 11* for detail as necessary:—

- (1) Ensure that the seat has been made safe for parking and that harness straps have been fully extended.
- (2) Remove the dust cover from the seat component of the P.E.C. and fit it into the stowage.
- (3) Sit in the seat.
- (4) Press the front end of the personal component (attached to clothing) of the P.E.C. into the front end of the seat component in an inclined attitude, and press down with a hinging motion until it clips into place. Test by inserting one or two fingers under the handle and attempting to lift it.
- (5) Thread the leg restraint cords through the quick-release couplings on the garters as follows. Thread the cord from the starboard snubbing unit under the seat pan, through the garter coupling of the left leg and then plug the end-fitting of the cord into the starboard taper socket on the front of the seat pan (*fig. 9*).

Note . . .

- (1) *If there is insufficient length of cord, pull forwards on the ring in the front of the snubbing unit and withdraw more cord.*
- (2) *Unless the personal component of the P.E.C. is mating correctly with the seat component, the plug will not lock in its socket.*
- (6) Similarly thread the port cord through the right garter and back to the port taper socket, thus crossing the cords. It does not matter which loop is in front, but do not interlace them.
- (7) Pull back any excess cord through the snubbing units leaving enough slack to enable the occupant to operate the rudder fully.
- (8) Adjust the height of the seat until a satisfactory position for flying is obtained, ideally with the head positioned centrally against the headrest cushion. Stretch the arms upwards towards the firing handle to ensure there is no restriction to firing handle access by the clothing.
- (9) Connect the survival pack lowering line on the left side to the quick-release coupling on the life jacket or pressure jerkin. The line should lie across the left thigh (*fig. 10*).
- (10) Bring the harness waistbelt across the body. Adjust the quick-release fitting so that it lies centrally with the waistbelt close to the body. Turn the quick-release fitting to the locked position.
- (11) Bring the negative-g strap up between the legs ensuring that it is to the REAR of the seat pan firing handle and NOT PASSED THROUGH IT, and also that the strap is not twisted (*fig. 9*).

- (12) Thread the lugs of the lap straps through their respective loops in the blue 'Y' piece of the negative-g strap and connect the lugs into the quick-release fitting on the waistbelt (the hoses to the P.E.C. pass under the right lap strap). The back pad should be drawn up by a ground crew member and the lumbar cushion adjusted to suit. Sit well back in the seat; any slack in the hoses to the P.E.C. should lie below the right lap strap to allow body movement without straining the hoses.

Note . . .

When connecting the first lug to the quick-release fitting, turn the disc knob anti-clockwise until the yellow line coincides with the dots on the body and insert the lug. The remaining lugs can be fitted without further manipulation of the disc knob.

- (13) Tighten each lap strap by pulling on the running end with one hand and pushing the standing end towards the buckle with the other hand to relieve the tension.
- (14) Tighten the negative-g strap by pulling DOWNWARDS on the running end of the strap and then smooth down the Velcro fastening.
- (15) Move the body about inside the harness, and then re-tighten the lap straps and the negative-g strap, repeating this process until the straps are really tight. It is most important that the lap straps and the negative-g strap are tight, as they provide the principal restraint under all stress conditions (fig. 9).
- (16) Bring the leg loops up between the legs and thread the left loop through the metal D-ring on the left lap strap. Repeat on the right side. If twisted correctly the leg loops will lie flat on the inside of the thighs (fig. 9).
- (17) Remove the ends of the shoulder straps from the stowed position. Arrange them under the life jacket or jerkin stole, thread the end fittings through the leg

loops and connect them to the quick-release fitting. The harness leg loops should engage on the metal lugs and not on the webbing above them, so that they will disengage freely on operating the quick-release fitting. To facilitate this engagement it is essential that the shoulder straps be extended fully (fig. 9).

- (18) To tighten the shoulder strap first take-up the slack on the blue inner (underneath) straps and then take up the slack in the brown outer (top) straps. When tightening these straps, pull on the running end with one hand to relieve the tension on the buckles. Ensure that there is no undue slack, but do not overtighten the shoulder straps as this causes the back to arch, which is a bad attitude for ejection.
- (19) This tightening will ruck that part of the lift-webs lying between the inner and outer straps. Obtain the assistance of a member of the ground crew to pull back the lift webs through the metal runners on the shoulders and then stow the excess length neatly (by lengthening the loops in the lift webs) behind the back.
- (20) Put on the flying and protective helmets (if this has not already been done) and fasten the chin straps. Fit the oxygen mask.

Note . . .

If the chin straps are not fastened, the helmets may be wrenched off during ejection. At high altitudes, this would mean the loss of vital oxygen supply.

- (21) Connect the Mic/Tel lead and oxygen mask tube. In the low altitude role (pressure jerkin not being worn) connect the mask tube spring clip to the D-ring on the life jacket stole.
- (22) Reach upwards and check that the face screen firing handle is within reach; DO NOT PULL.
- (23) Conduct pre-flight oxygen checks (see Pilot's Notes).

- (24) With assistance from a ground crew member, ensure that the various safety pins are removed and stowed.

EMERGENCIES

27. For drill and procedure to be taken in emergencies refer to Pilot's Notes, A.P.4326J - P.N.

LEAVING THE AIRCRAFT AFTER LANDING

28. When leaving the aircraft after landing, the following procedure should be used:-

- (1) Remove the safety pins from their stowages and fit them to the face screen firing handle, the seat pan firing handle and the guillotine sear. Obtain assistance from a member of the

ground crew to insert the safety pins in the face screen firing handle and the guillotine sear.

- (2) Disconnect the personal component of the P.E.C. by pulling upwards on the handle (this will also free the leg restraint cords).
- (3) Operate the harness quick-release fitting, free the straps and return the quick-release fitting to the locked position.
- (4) Disconnect the survival pack lowering line from the life jacket or pressure jerkin.
- (5) Leave the seat.
- (6) Fit the dust cover to the P.E.C.

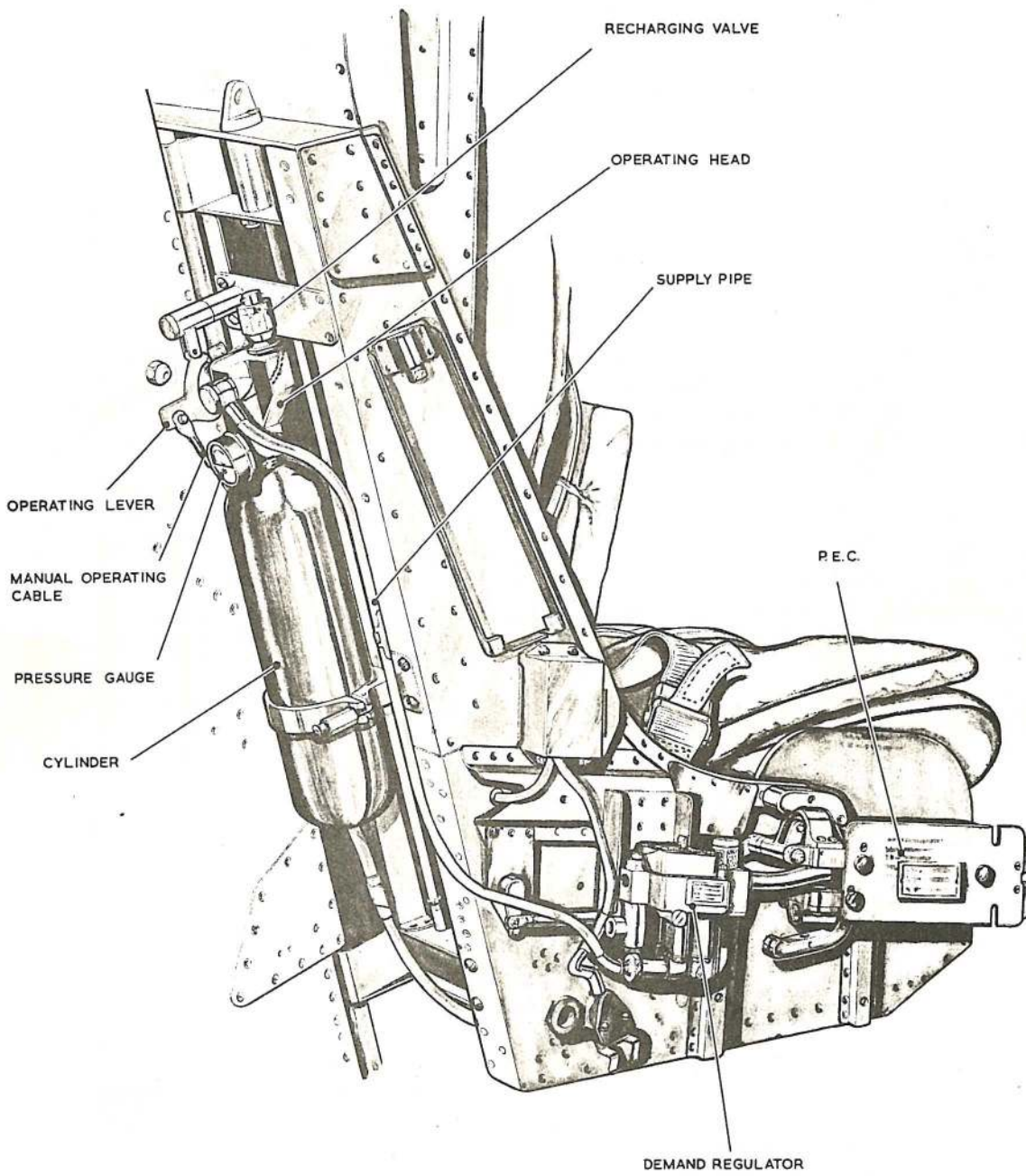

Fig. 1. Demand emergency oxygen system

RESTRICTED

10

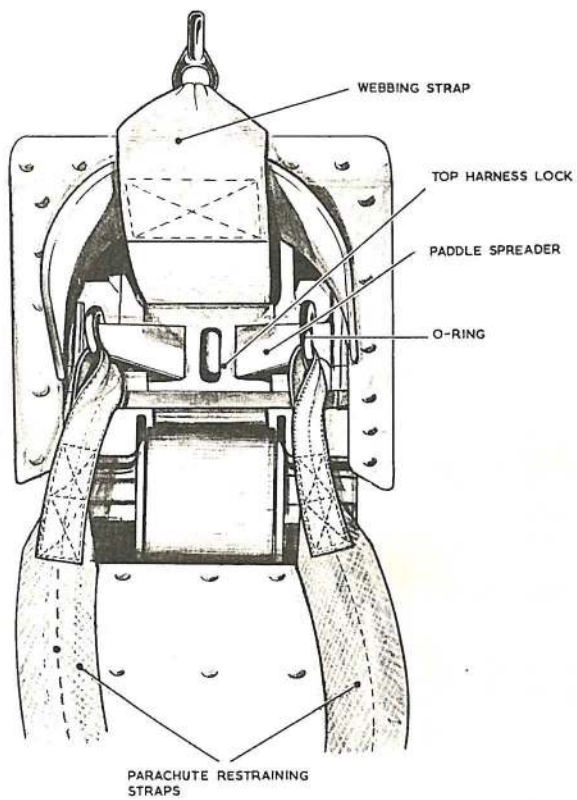

Fig. 2. Attachment of parachute restraining straps to paddle spreaders

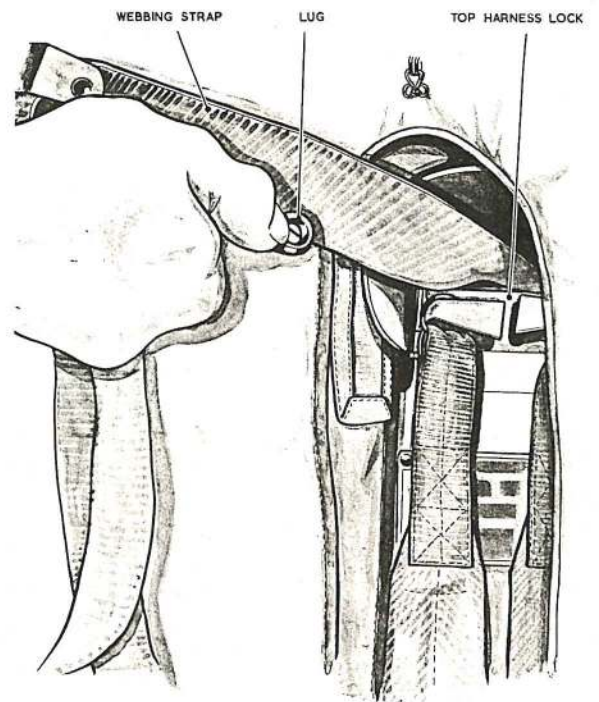

Fig. 3. Insertion of top harness lock

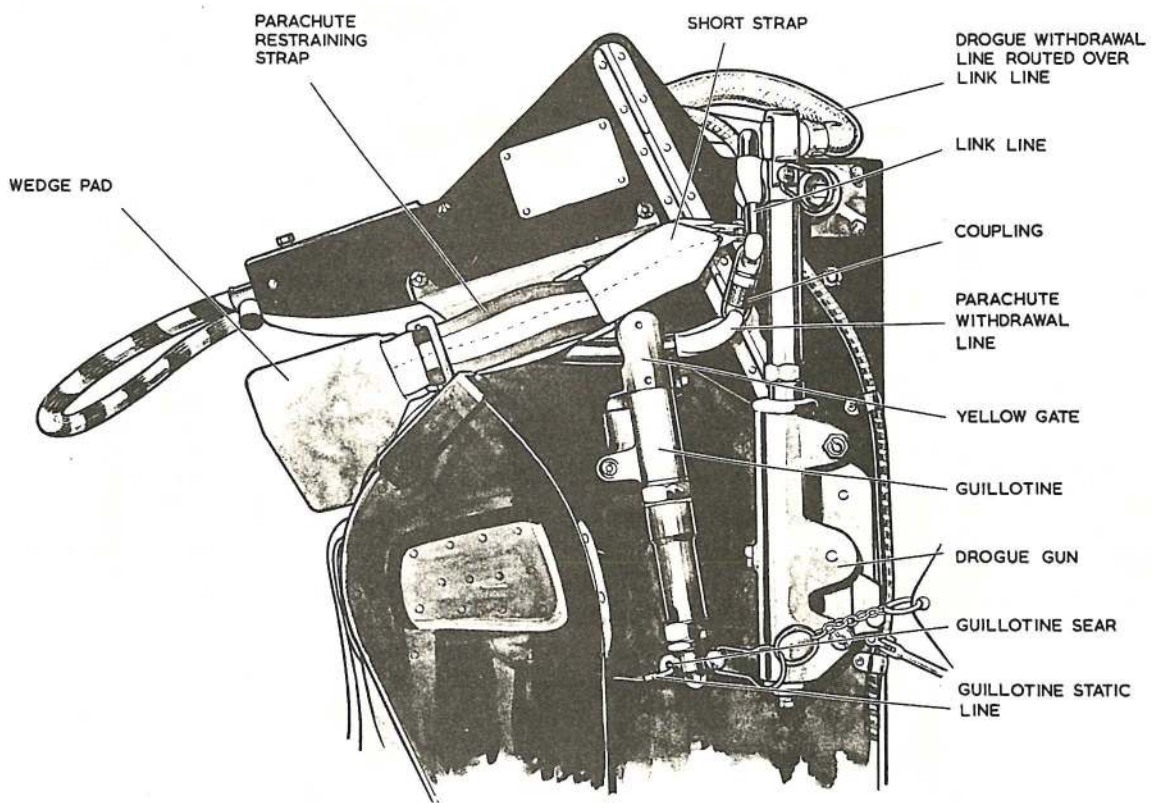

Fig. 4. Arrangement on port side of drogue container

RESTRICTED

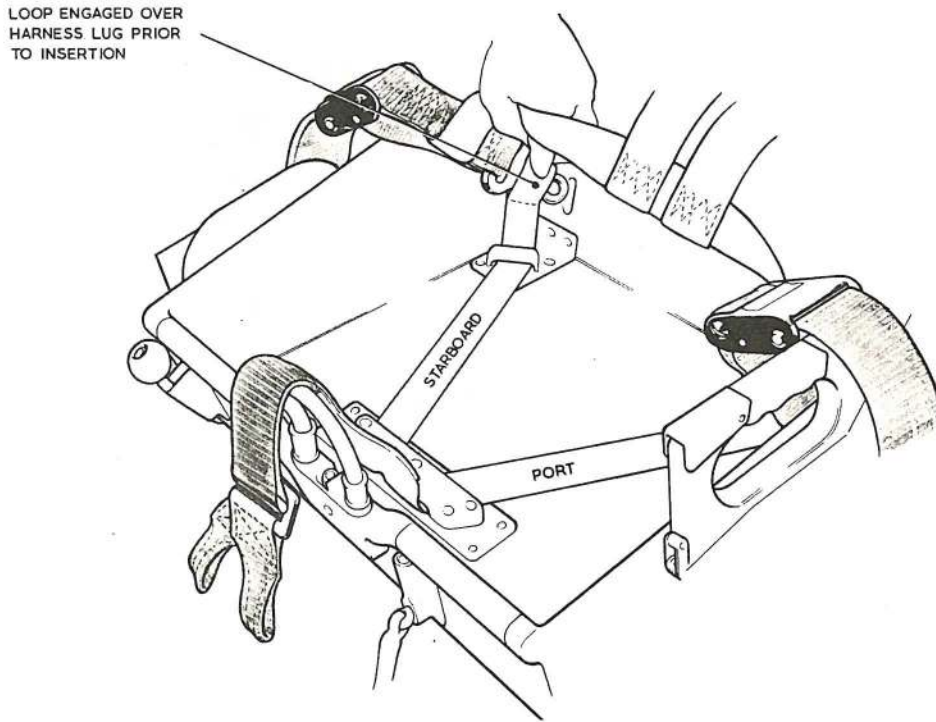

Fig. 5. Fitting negative-G strap

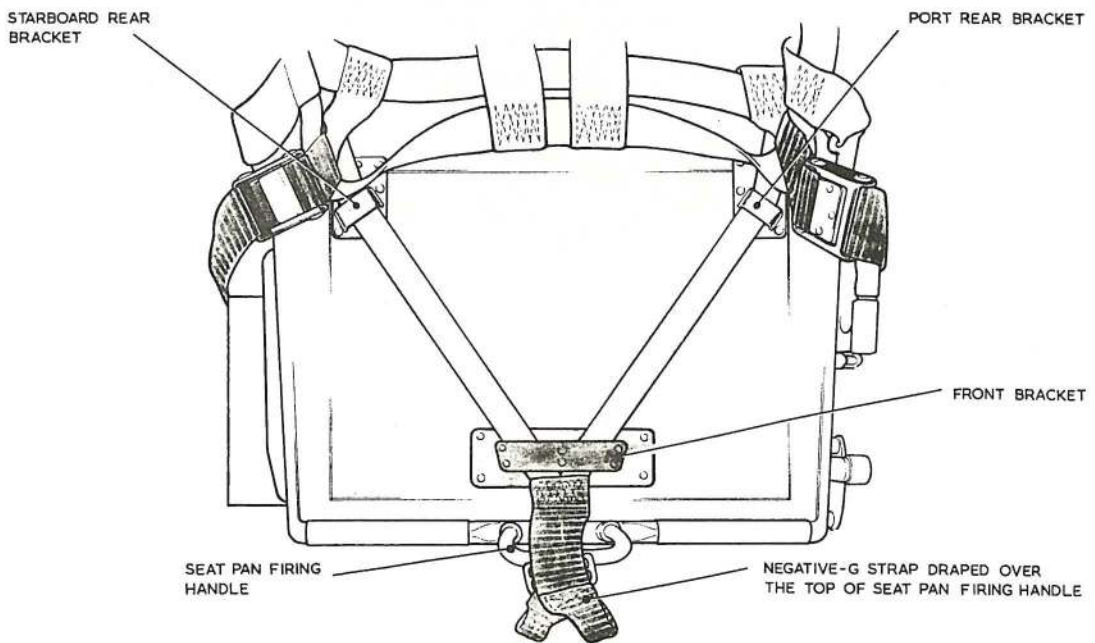

Fig. 6. Negative-G strap fitted

RESTRICTED

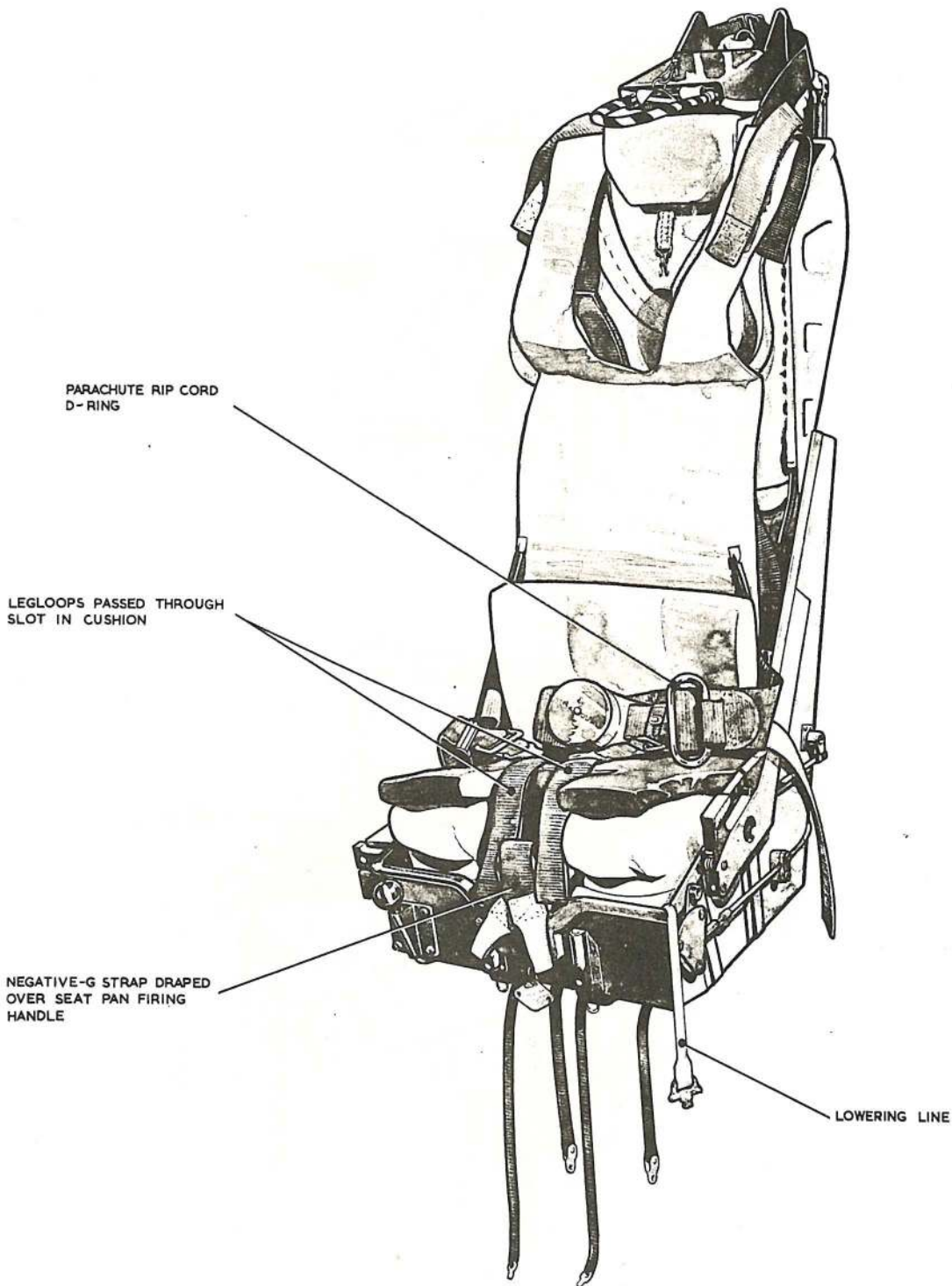

Fig. 7. The seat equipped (port)

RESTRICTED

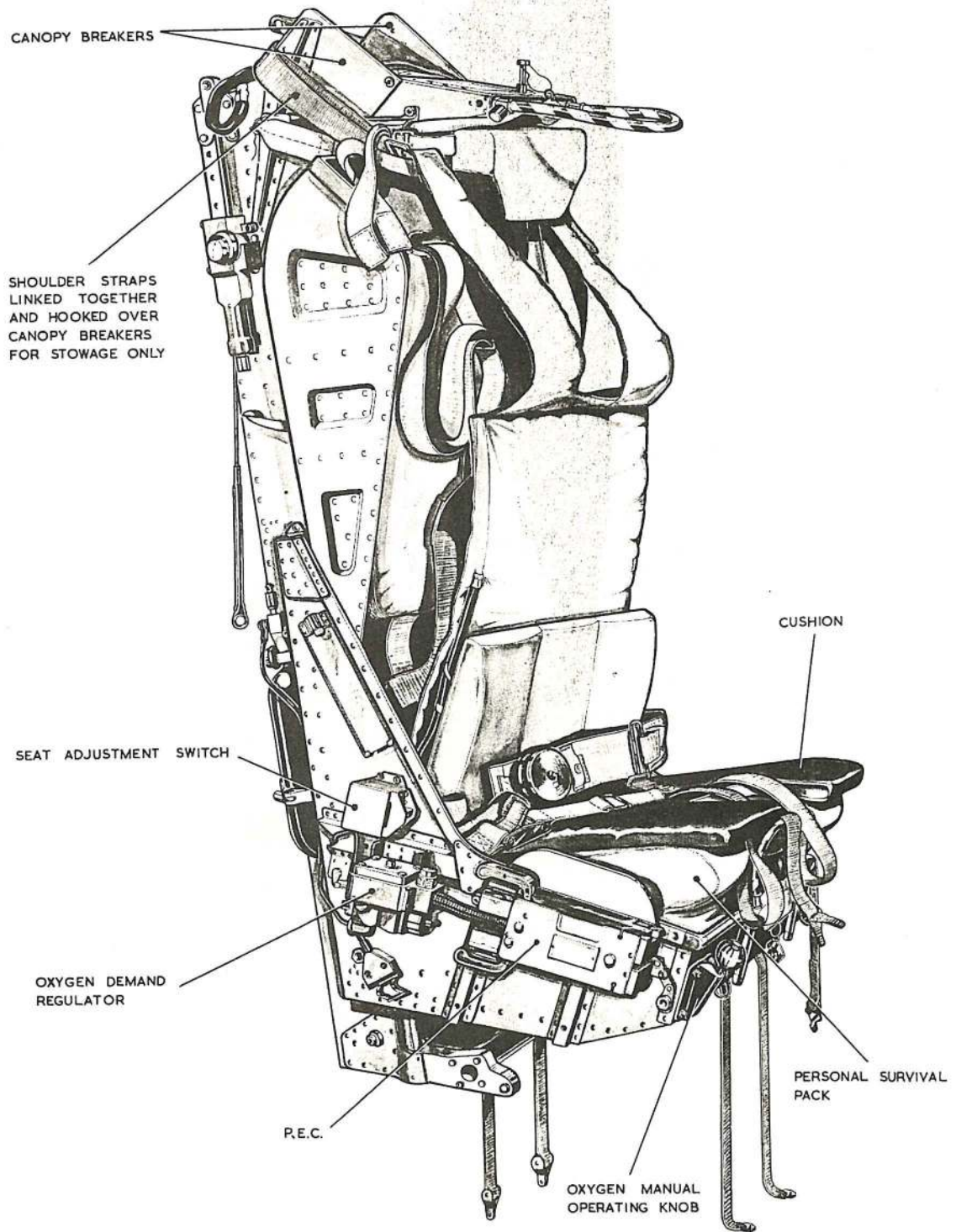

Fig. 8. The seat equipped (starboard)

RESTRICTED

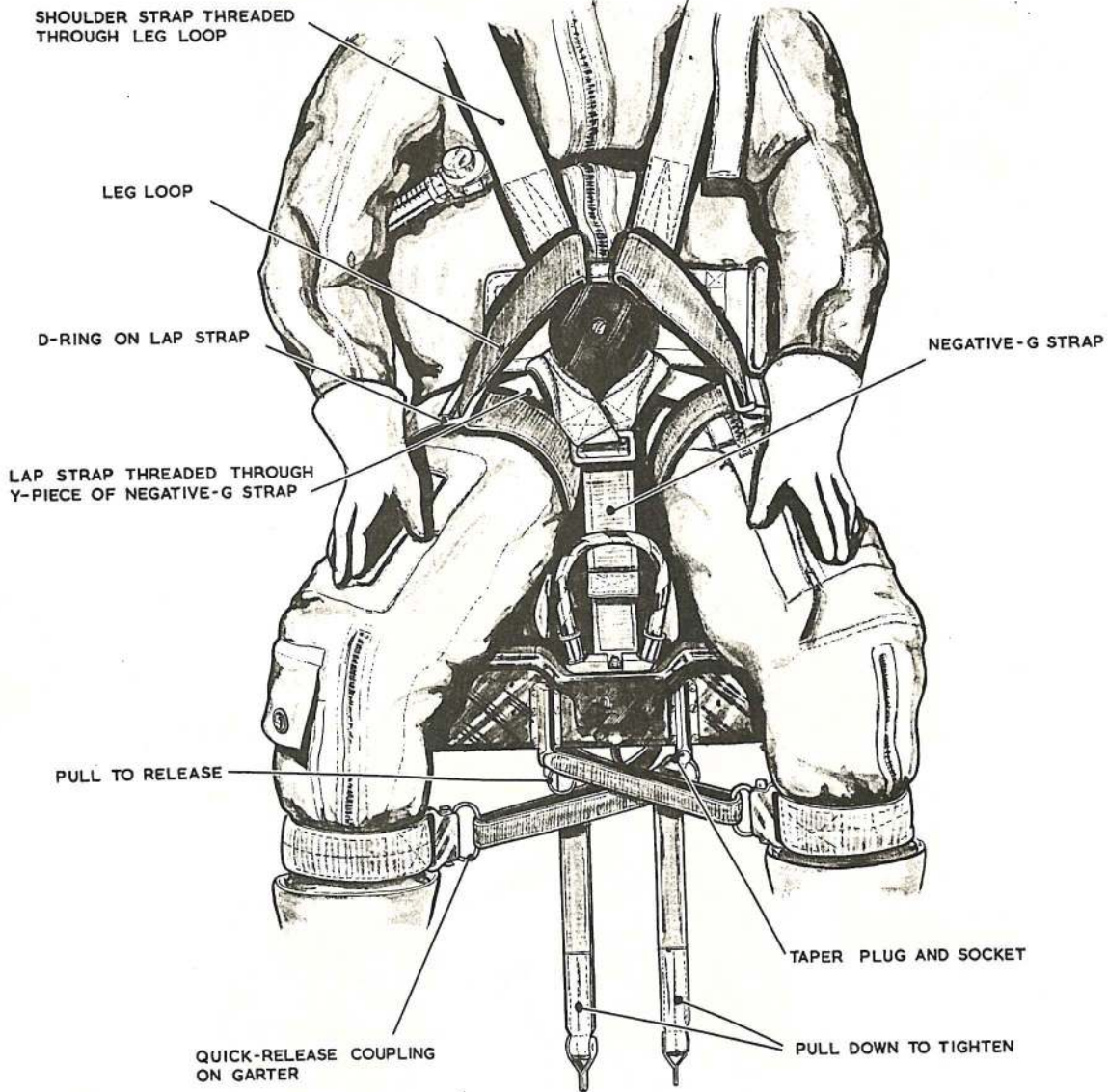

Fig. 9. Arrangement of leg restraint cords and harness straps

RESTRICTED

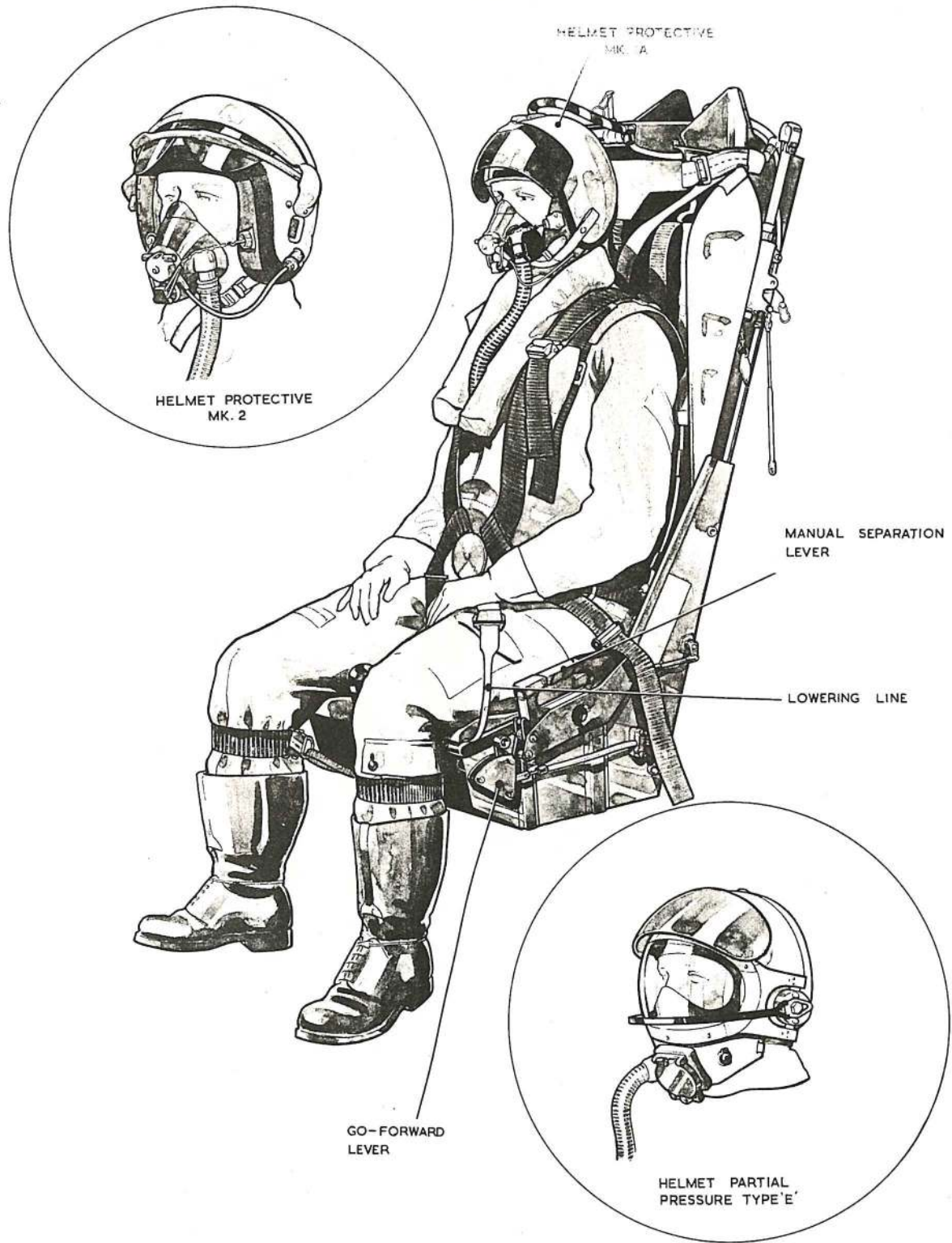

Fig. 10. The seat occupied (port)

RESTRICTED

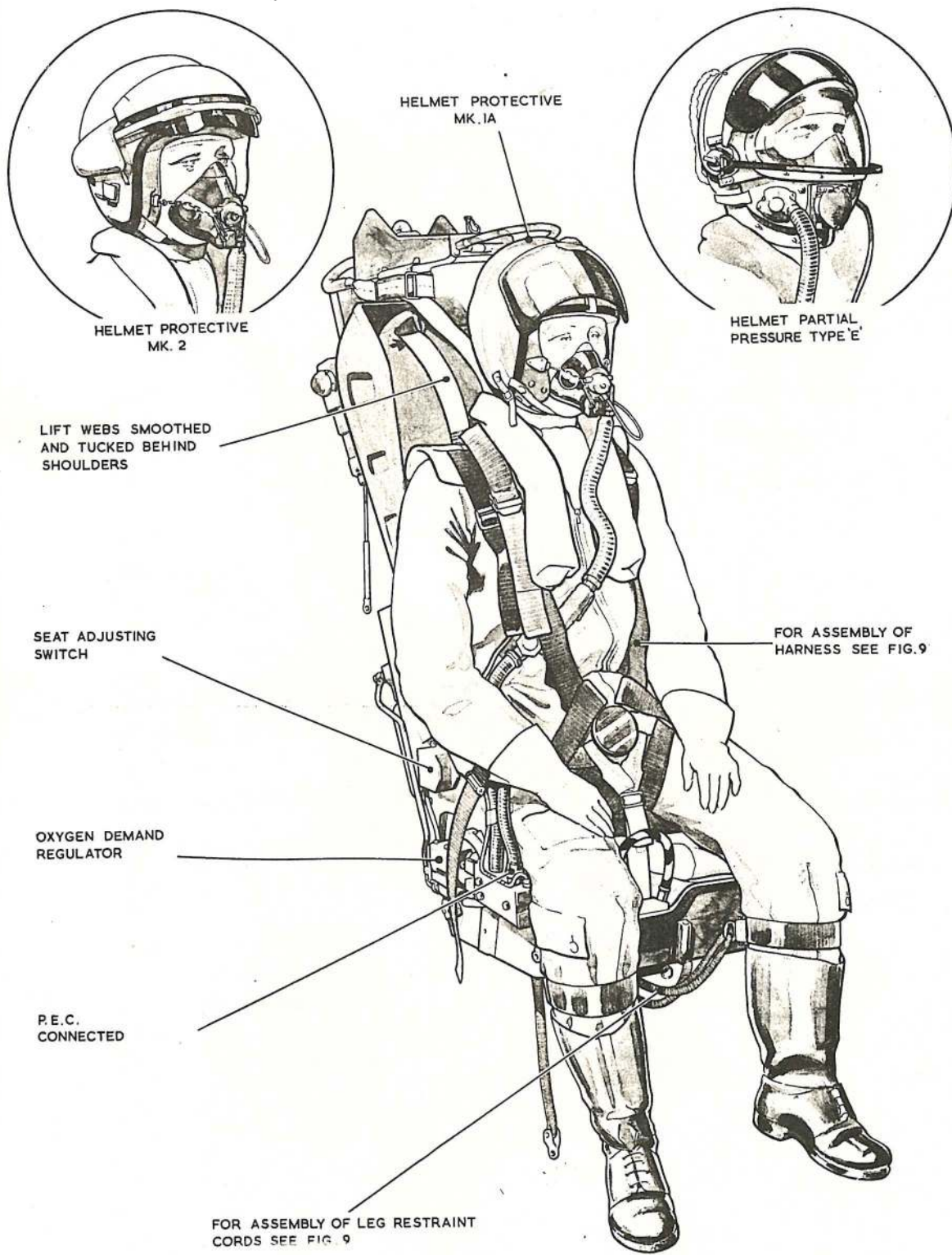

Fig. 11. The seat occupied (starboard)

RESTRICTED

This file was downloaded
from the RTFM Library.
Link: www.scottbouch.com/rtfm

Please see site for usage terms,
and more aircraft documents.

