

Chapter 5

LIGHTNING T Mk. 5

LIST OF CONTENTS

	Para.		Para.
Introduction	1	Equipping the seat	15
Composition of the assembly ..	2	Strapping-in procedure	17
The Type 4 BSB ejection seat and associated equipment ..	3	Emergencies	18
Connections to the aircraft	14	Leaving the aircraft after landing ..	19

LIST OF ILLUSTRATIONS

	Fig.		Fig.
Seat mounted oxygen group assembly	1	Arrangement of leg restraint cords and harness: upward pull negative-G restraining strap fitted	7
Arrangement on port side of drogue container	2	Arrangement of harness: downward pull negative-G restraining strap is fitted	8
Installation of negative-G strap: prior to Mod. E.S.2690 ..	3	The seat occupied (port)	9
Installation of negative-G strap: post Mod. E.S.2690 ..	4	The seat occupied (starboard) ..	10
The seat equipped (port)	5		
The seat equipped (starboard)	6		

LIST OF APPENDICES

	App.
Flying clothing	1
(to be issued later)	
Type 4 BSB Mk.2 ejection seat ..	2

Introduction

1 This chapter is primarily concerned with the installation of equipment in or on the seats, strapping-in procedure, and the drill to be used when leaving the aircraft after landing. A brief description of the various components of the A.E.A. is included, full details will be found in the publications referred to in the appropriate paragraphs. Details of flying clothing and dressing procedures will be issued as an appendix to this chapter at a later date.

COMPOSITION OF THE ASSEMBLY

2. Two aircrew equipment assemblies are fitted to this aircraft, each of which consists of

the following items:—

Ejection seat	Type 4 BSB fitted with seat mounted oxygen group assembly
Parachute assembly	Back Type Mk. 28
Personal survival pack	Type V (c/w cushion)
Flying clothing assembly	To be issued later

The type 4 BSB ejection seat and associated equipment

3. The Type 4 BSB seat is ejected from the aircraft by a cartridge-operated gun and may be used for low level ejection provided that the air

speed is over 90 knots and the aircraft flight path is straight and level. During ejection the seat slides in two guide rails attached to the cylinder barrel of the ejection gun; the barrel is also fitted with brackets which enable the gun to be bolted to the airframe structure.

4. The back type Mk. 28 parachute assembly incorporates a combined safety/parachute harness, the pack is housed in a container which forms an integral part of the seat and the harness is attached to the seat by lugs at three quick-release points, one under the support bracket for the parachute pack and two at the back of the seat pan. These lugs may be separated from the seat by the action of a barostatic time-release unit or by a manual separation lever on the port side of the seat pan to the rear. Forward on the port side of the seat pan is a "go-forward" lever which, when the knob is pushed forward, releases the snub lever and allows the occupant to lean forward in the cockpit without separating the parachute assembly from its attachment points, forward movement of the occupant is only possible when the lever is held forward against the spring. When the lever is released, the occupant may maintain the forward position of the body but, on returning to the upright position, the spring will take up the slack and the snub lever will lock the system against renewed forward movement.

5. Housed in the seat pan is the Type V personal survival pack (P.S.P.) which, with the cushion, forms a comfortable seat for the occupant. The pack is attached to the combined harness by side quick-release connectors and its lowering line is connected to the flying clothing during strapping-in. A negative-G restraining strap is fitted to restrain the seat occupant against negative-G forces. The rear of the strap is attached to the two bottom harness lugs locked in the back of the seat pan, and the front of the strap is attached to the lugs of the harness lap straps which engage in the harness quick-release fitting. Prior to modification E.S.2690 the negative-G strap is routed over the top of the personal survival pack, through a bracket on the inside of the front face of the seat pan behind the seat pan firing handle, and upwards to the lap straps. When modification E.S.2690 is embodied, the strap is routed underneath the personal survival pack, through brackets in the floor of the seat pan (one at the front and two at the rear), and thence upwards to the lap straps. The strap introduced by modification E.S.2690 is also fitted with an improved buckle

to facilitate adjustment. The procedures for installing both types of strap when equipping the seat, are described in para. 15.

6. A seat mounted oxygen group assembly is bolted to the starboard side and back of the seat pan. The assembly contains:-

- (1) A quick-release plug, to which is connected the main oxygen supply from the aircraft.
- (2) A remote control demand regulator (Type 120) to control the main oxygen flow
- (3) An emergency oxygen cylinder and release mechanism.
- (4) A stand by demand regulator to control the emergency oxygen flow
- (5) A low pressure warning switch in circuit with the aircraft warning system which gives warning if the main oxygen supply falls below a predetermined pressure.
- (6) A ground test valve used for conducting ground tests on the face mask and pressure jerkin.
- (7) The personal equipment connector.

7. The components of the assembly are mounted on a detachable tray which consists of a side panel and a rear panel riveted together at right angles to each other; the complete assembly with all the components is then bolted to the seat structure. The emergency oxygen supply is turned on automatically during ejection, but provision is also made for manual operation in the event of failure of the main oxygen supply during normal flight. Full details of the seat mounted oxygen group assembly and its components are contained in A.P 1275G, Vol. 1.

8. The personal equipment connector (P E.C.), bolted to the side plate of the seat mounted oxygen group assembly, enables the seat occupant to connect or disconnect in one action the main and emergency oxygen, the air ventilated suit, the anti-G suit and the Mic/Tel services. During ejection, it automatically disconnects the air ventilated suit, the anti-G suit and the Mic/Tel services between the seat and the aircraft. The main oxygen supply between the seat and the aircraft is disconnected during ejection, at the quick-release plug mounted on the seat mounted oxygen group assembly. When separation of seat

and occupant occurs after ejection, the P.E.C. enables the occupant to be automatically disconnected from all the services on the seat. The following is a brief description of the three main components of the P.E.C., a full description is contained in Sect. 1, Chap. 5.

- (1) *The aircraft component.* Connected to the cockpit floor by a static line, and to aircraft services for A.V.S., anti-G and Mic/Tel systems.
- (2) *The seat component.* Bolted to the side plate of the seat mounted oxygen group assembly, which is in turn bolted to the starboard side of the seat pan, it is connected to the main oxygen supply through the remote control demand regulator and to the emergency oxygen cylinder through the standby regulator.
- (3) *The personal component.* Attached to the flying clothing and connected to the oxygen mask, pressure jerkin, air ventilated suit, anti-G suit and Mic/Tel lead.

9. Two firing handles are fitted to the seat. The face screen handle, which has an integral face screen, projects from the front of the drogue container; the seat pan handle is partly recessed into the top front edge of the seat pan and is intended for use only when the occupant is unable to reach the face screen handle, e.g., when subjected to high 'G' forces. Both handles are connected to the hood jettison mechanism and when either handle is pulled the hood is jettisoned immediately, the seat being ejected after a delay of one second. A restrictor is fitted to the time-delay firing unit of the ejection gun to prevent operation of the gun until the hood has been jettisoned. A separate hood jettison handle is also provided in the aircraft to enable the hood to be jettisoned without ejection taking place.

10. Leg restraint cords, fitted through snubbing units under the seat pan and terminating in taper plugs engaged in spring loaded sockets on the front of the seat pan, ensure that the occupant's legs are drawn back to the seat pan and restrained there during and after ejection, thereby reducing the risk of injury. An interconnection between the spring loaded sockets and the P.E.C., releases the leg restraint cords as the personal

component of the P.E.C. is released. This interconnection also ensures that the leg restraint cords cannot be connected until the personal component of the P.E.C. is correctly engaged with and locked to the seat component. If the personal component of the P.E.C. becomes disconnected in flight, the leg restraint cords will be released and their taper plugs must be re-inserted in the sockets after the personal component is replaced.

11. Seat height adjustment is achieved by an electrically operated actuator, the switch for the actuator being situated on the starboard console immediately inboard of the coder unit controls. The switch is spring loaded to the central (OFF) position. A forward movement of the switch lowers the seat and a rearward movement raises it.

12. Fully automatic facilities are provided to withdraw the parachute canopy from its pack and separate the occupant from the seat after ejection. Manual override controls, the first D-handle on the combined harness waistbelt and the manual separation lever on the side of the seat pan, enable the occupant to disconnect the parachute automatic withdrawal device and the combined harness from the seat if the need arises to (a) make a manual bale-out or (b) make a manual separation from the seat after ejection. The parachute is then deployed by operating the second D-handle on the waistbelt.

Note

If manual operation is employed the parachute automatic withdrawal device MUST be rendered inoperative by pulling the first D-handle.

13. A complete description of the Mk. 4 BSB seat and personal equipment connector will be found in A.P.4288D, Vol. 1; information concerning the parachute assembly and Type V personal survival pack is contained in A.P.1182A, Vol. 1 (2nd Edtn), and A.P.1182C, Vol. 1, Book 2 respectively

Connections to the aircraft

14. When the seat is installed in the aircraft and is properly equipped, the following items are connected to the aircraft:—

- (1) *Port side of seat:—*
 - (a) Static rod from drogue gun.

- (2) *Starboard side of seat:-*
- (a) Static rod from barostatic time-release unit.
 - (b) Static line from aircraft component of P.E.C.
 - (c) Main oxygen supply hose.
 - (d) Air ventilated suit air supply hose.
 - (e) Anti-G suit air supply hose.
 - (f) Mic/Tel lead.
 - (g) Electrical lead to seat actuator.
- (3) *Underside of seat:-*
- (a) Leg restraint cords.
- (4) *Top of seat:-*
- (a) Hood jettison unit operating cable.
 - (b) Static line from hood to restrictor.

EQUIPPING THE SEAT

15. Before equipping the seat ensure that it has been made safe for servicing in accordance with current instructions.

16. The following procedure is to be adopted when installing the equipment in the seat; refer to fig. 1 to 6 for details as necessary

- (1) The seat mounted oxygen group assembly (*fig. 1*) must be fitted before the seat and ejection gun assembly are installed in the aircraft. Detailed instructions for fitting the oxygen group assembly are contained in A.P.4288D, Vol. 1.
- (2) Remove and retain the safety pin from the emergency oxygen cylinder operating head.
- (3) Ensure that the leg restraint cords are clear of the seat and that the seat pan is clean.
- (4) Place the parachute pack on its support bracket temporarily and ensure that the pack restraining straps and headrest cushion are immediately available.
- (5) Ensure that the harness straps are not twisted. Operate the harness "go-forward" lever, pull out the strap under the support bracket and pass it downwards through the D-shackle.
- (6) Lift the parachute pack forward (this may be done before pulling out the

centre strap if more convenient), pass each pack restraining strap O-ring over the centre strap lug and insert the lug into the attachment point below the bracket. Pull sharply on the harness to ensure that the lug is locked securely

- (7) Pass the pack restraining straps through the arch of the pack, replace the pack on its support bracket and ensure that the restraining straps are not twisted.
- (8) Position the headrest cushion centrally on top of the parachute pack and ensure that it is not inverted.
- (9) Pass the port pack restraining strap over the drogue link line, through the buckle on the short strap at the port side of the drogue container and then forward through the buckle on the port side of the headrest cushion.

Note .

When passing the parachute restraining strap through the buckle on the short strap at the side of the drogue container, ensure that it passes through from outside inwards.

- (10) Pass the starboard pack restraining strap through the buckle on the short strap at the starboard side of the drogue container (refer to the note following sub-para. (9)) then forward through the buckle on the starboard side of the headrest cushion.
- (11) Tighten the pack restraining straps, ensuring that the headrest cushion remains central on top of the parachute pack.
- (12) Connect the two halves of the drogue link line coupling, ensuring that the line passes under the port pack restraining strap and UNDER THE DROGUE WITHDRAWAL LINE.
- (13) Prior to embodiment of Modification E.S.2690, fit the negative-G restraining strap as follows -
 - (a) With the blue Y-section removed, pass the buckle end of the white Y-section through the anchor bracket inside the front of the seat pan from bottom to top. Attach the straight part of the blue Y-section to the

- buckle so that the free end is facing forward with the Y-part uppermost.
- (b) Place the personal survival pack in the seat pan and route the white Y-section of the strap over the top of the personal survival pack to the rear bottom harness locks on the seat. Engage the looped ends of the strap over their appropriate bottom lock harness lugs and insert the lugs in the locks. Pull sharply on the harness to ensure that the lugs are securely locked and ensure that the straps lie flat across the pack.
 - (c) Pull upwards on the blue Y-section to settle the survival pack in the pan, and drape the front of the strap OVER THE TOP of the alternative firing handle.
- (14) When Modification E.S.2690 is embodied, fit the negative-G restraining strap as follows.—
- (a) Thread the white straps through the front bracket on the floor of the seat pan from front to rear, ensuring that the yellow tab on the buckle is facing forward. The white straps are marked 'PORT' and 'STARBOARD' and it is essential that they are so positioned to ensure correct installation.
 - (b) Pass the straps rearwards and thread each strap through its respective rear bracket in the floor of the seat pan.
 - (c) Engage the looped end of each strap over its respective bottom lock harness lug and insert the lugs into their respective bottom locks. It may be necessary to partially depress the harness release lever beneath the barostatic time-release unit to facilitate insertion of the lugs. Check that they have locked correctly by pulling on the lugs.
 - (d) Drape the blue Y-section of the strap OVER THE TOP of the seat pan firing handle.
 - (e) Lift the harness clear of the seat pan and insert the personal survival pack into the pan.
- (15) Fit the cushion to the seat strap of the harness as follows:—
- (a) Pass the strap under the cushion and locate it in position with the two press-studded beackets.
 - (b) Pass the leather covered straps of the cushion through the webbing loops on either side of the P.S.P from rear to front. Pass the leg straps of the combined harness up through the slot in the cushion and secure the cushion to the pack with the lift-the-dot fasteners at the front.
- (16) Connect the side quick-release couplings of the P.S.P to their harness components.
- (17) Insert the harness sticker straps into the spring clips on the inside of the seat pan and ensure that they pass outside the P.S.P side quick-release couplings.
- (18) Place the harness straps in the stowage clips situated immediately below the windscreen arch under the cockpit coaming.
- (19) After the seat has been equipped, ensure that the safety pins remain in their 'safe for servicing' positions and report to the N.C.O. i/c servicing.

STRAPPING-IN PROCEDURE

17 The procedure for strapping-in is as follows, refer to fig. 7 to 10 for detail as necessary.—

- (1) Ensure that the seat is made safe for parking in accordance with current instructions.
- (2) Before entering the seat, ensure that the harness is securely attached to its anchorages by pulling on the straps, individually, at each attachment point.
- (3) Sit in the seat and adjust its height to approximately the middle position, this enables the seat pan firing handle safety pin to be removed at a later stage without fouling the control column.
- (4) Remove the dust cover from the seat

component of the P.E.C. and fit it into its stowage on the right-hand side of the seat pan.

- (5) Fit the personal component of the P.E.C. to the seat component and apply pressure under the handle (without touching the release catch) to check that it is securely locked to the seat component.
- (6) Connect the P.S.P lowering line to its corresponding fitting on the pressure jerkin or life-jacket, as appropriate, and ensure that it passes outside the left leg.
- (7) Pass the left-hand leg restraint cord through the right leg garter D-ring and plug it into the socket above the left-hand snubbing unit. Pass the right-hand leg restraint cord through the left leg garter D-ring and plug it into the socket above the right-hand snubbing unit. Pull sharply on each cord to ensure that it is securely locked in its socket (remember that unless the personal component of the P E.C. is securely fitted to the seat component the leg restraint cords cannot be secured in their sockets). It is not important which cord is secured first so long as the cords are not interlaced.
- (8) Adjust the leg restraint cords in the snubbing unit to obtain the required range of leg movement.

Note .

If the cords are too short, pull the ring of each snubbing unit and ease the cords forward; slack can be taken up by pulling the cords backwards through the snubbing units.

- (9) Adjust the parachute back pad and the height of the lumbar cushion. Position the harness waist-belt against the body. Draw up the blue Y-section of the negative-G restraining strap and pass the appropriate looped end over its respective lap strap. Ensure that the adjustment buckle and free end of the strap face forward and that the Y-section lies flat against the inside of the thighs. Insert the lugs of the lap straps into the quick-release fitting, ensuring that the right-hand

lap strap passes outside the hoses from the personal component of the P E.C.

Note . .

When an inertia-proof quick-release fitting is incorporated, turn the disc knob in an anti-clockwise direction until the yellow line passes the dots on the body; retain the knob in this position and insert the first lug. Repeat the operation when inserting the three remaining lugs.

- (10) Tighten the lap straps.

Note . . .

The lap straps must be as tight as possible. To tighten these straps fully, it is necessary to relieve the tension in the 'standing end' of each strap (the ends carrying the buckles) otherwise the buckles become stiff. Pull on the 'running end' with one hand and push the webbing of the 'standing end' towards the buckle with the other; it may be necessary to do this several times before the straps are really tight and while it is being done the occupant should push himself well back into the seat.

- (11) Tighten the negative-G restraining strap as follows.—

- (a) *Prior to Modification E.S.2690* Pull UPWARDS on the free end of the strap until the strap is as tight as possible and tuck the free end back under the elastic band.

- (b) *When Modification E.S.2690 is embodied.* Pull DOWNWARDS on the free end of the blue strap until the strap is as tight as possible and ensure that the free end is then tucked down BEHIND the alternative firing handle. The strap introduced by Modification E.S.2690 is fitted with a buckle equipped with a snubber, which is released by pulling downwards on the yellow tab attached to the snubber lever to loosen the strap.

- (12) Pass the left leg loop upwards over the inside of the thigh and through the D-ring on the left strap (from the inside of the ring towards the outside of the

leg). Bring the end of the leg loop over towards the quick-release fitting, pass the lug of the left shoulder strap through the leg loop (from the top downwards) and insert the lug into its appropriate slot in quick-release fitting; snug the loop down over the lug. Repeat these operations for the right leg loop and shoulder strap.

- (13) Remove the safety pin from the seat pan firing handle and place it in its stowage on the console.
- (14) Adjust the sitting height to the desired position (ideally the head is to be located centrally against the headrest cushion).
- (15) Ensure that the shoulder straps pass under the folds of the life-jacket or pressure jerkin stole; tighten the inner (BLUE) straps and then the outer (KHAKI) straps.

Note . . .

It is undesirable to tighten these straps excessively since this action may arch the back and produce an unsuitable position for ejection. The inner straps are not to press down on the shoulders appreciably in ordinary conditions; equally there is to be no slack, so that in inverted flight these straps can take some of the weight off the lap straps as the body tends to stretch. The outer straps are to be similarly adjusted to prevent forward movement of the shoulders.

- (16) Connect the oxygen supply hose from the personal component of the P E.C. to the oxygen mask or partial pressure helmet. Securely fasten the chin straps and connect the Mic/Tel lead.
- (17) Remove the safety pin from the face screen firing handle and place it in the stowage on the console (this is normally done by a member of the ground crew;

if one is not available, the pilot is to remove and stow the pin prior to strapping-in).

EMERGENCIES

18. Instructions for dealing with emergencies are contained in A.P.4700E-P.N, to which reference is to be made, as necessary

LEAVING THE AIRCRAFT AFTER LANDING

19. The following sequence should be used when leaving the aircraft after landing:-

- (1) Remove the safety pins from their stowage on the console; fit the short pin through the seat pan firing handle and hand the others to the ground crew member who will then fit the long pin through the face screen firing handle lock.

Note . . .

If a ground crew member is not available, the pilot is to fit the face screen firing handle safety pin before leaving the cockpit.

- (2) Operate the harness quick-release fitting, free the harness straps (including the negative-G strap) and return the fitting to the locked position. Stow the straps in the clips provided in the cockpit.
- (3) Disconnect the personal component of the P E.C. from the seat component; remove the dust cover from its stowage and fit it to the seat component.
- (4) Free the leg restraint cords from the garters.
- (5) Disconnect the P S.P lowering line from the life-jacket or pressure jerkin, as appropriate.
- (6) Disconnect the Mic/Tel lead.
- (7) Vacate the aircraft.

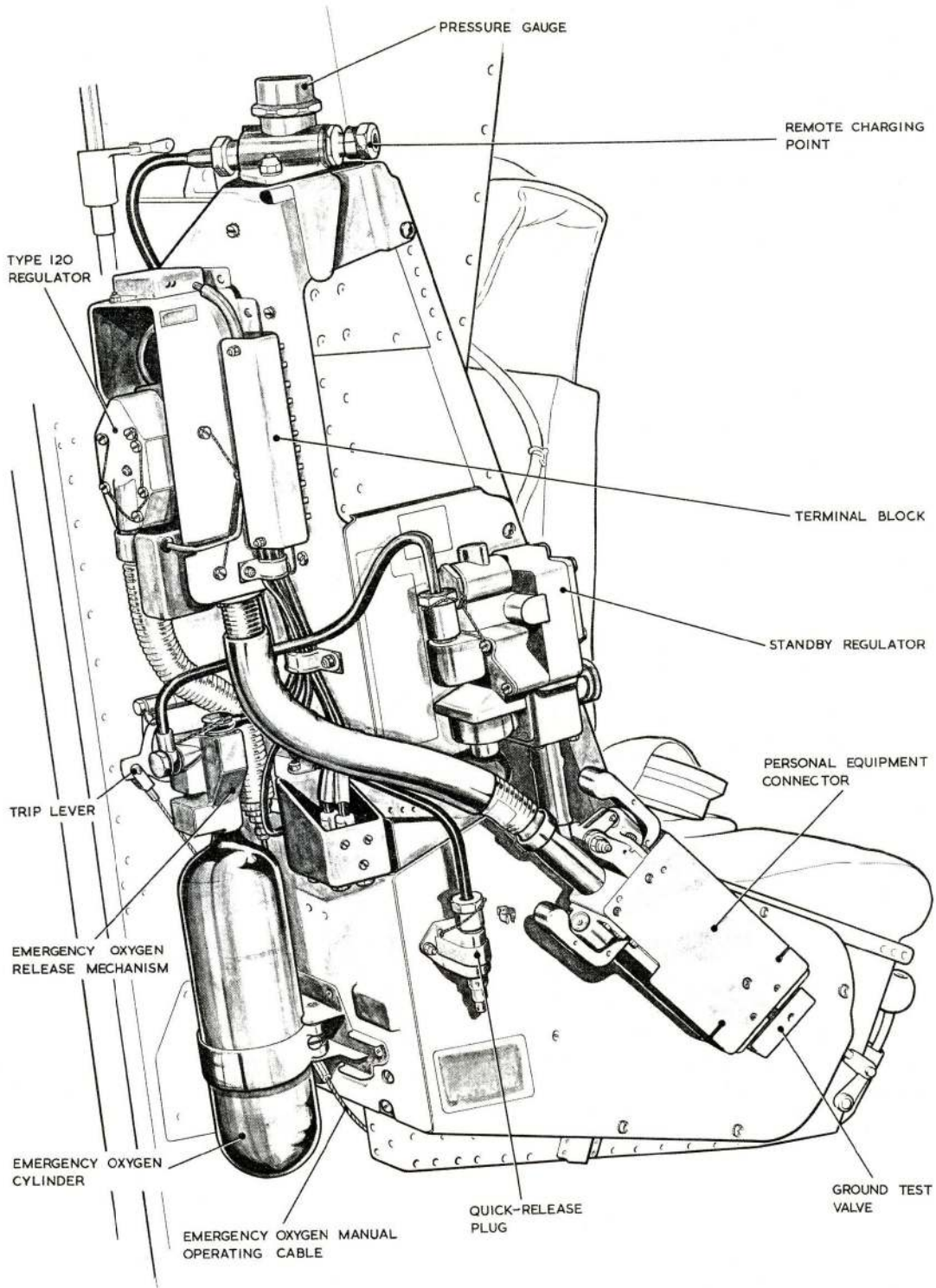

Fig. 1 Seat mounted oxygen group assembly

RESTRICTED

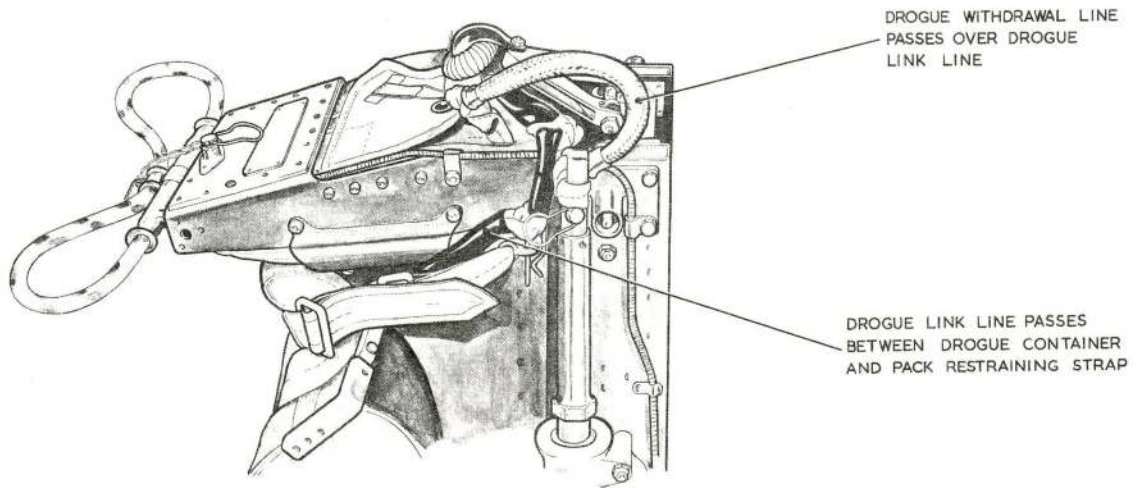

Fig. 2. Arrangement on port side of drogue container

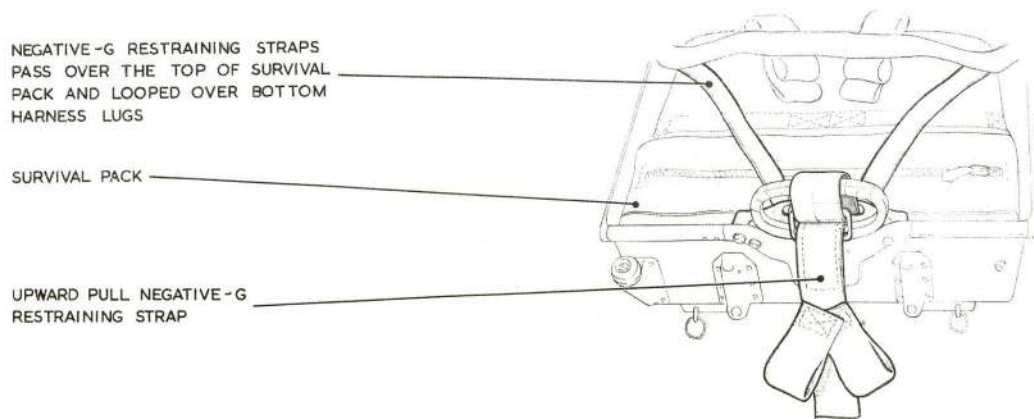

Fig. 3. Installation of negative-G strap: prior to Mod. E.S.2690

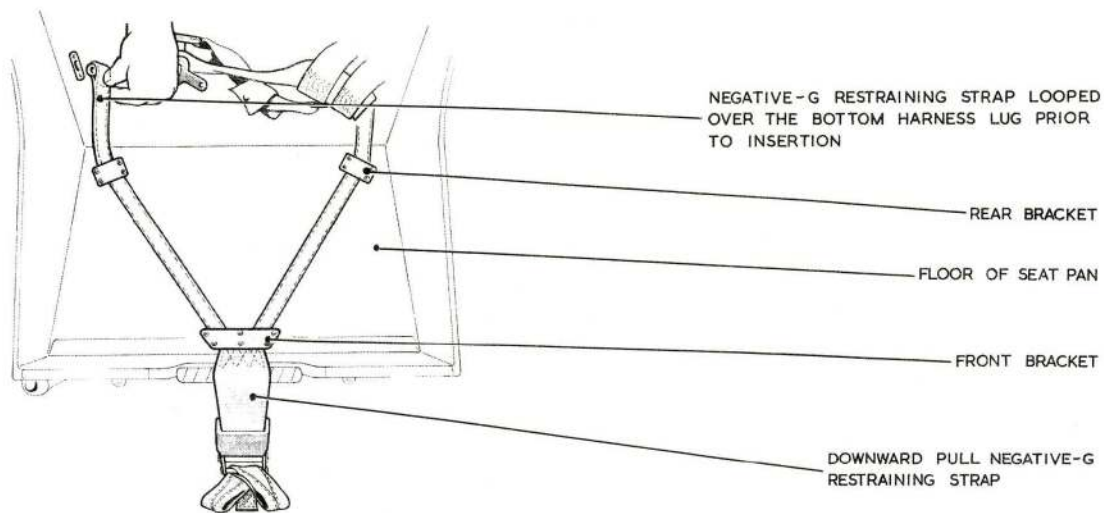

Fig. 4. Installation of negative-G strap: post Mod. E.S.2690

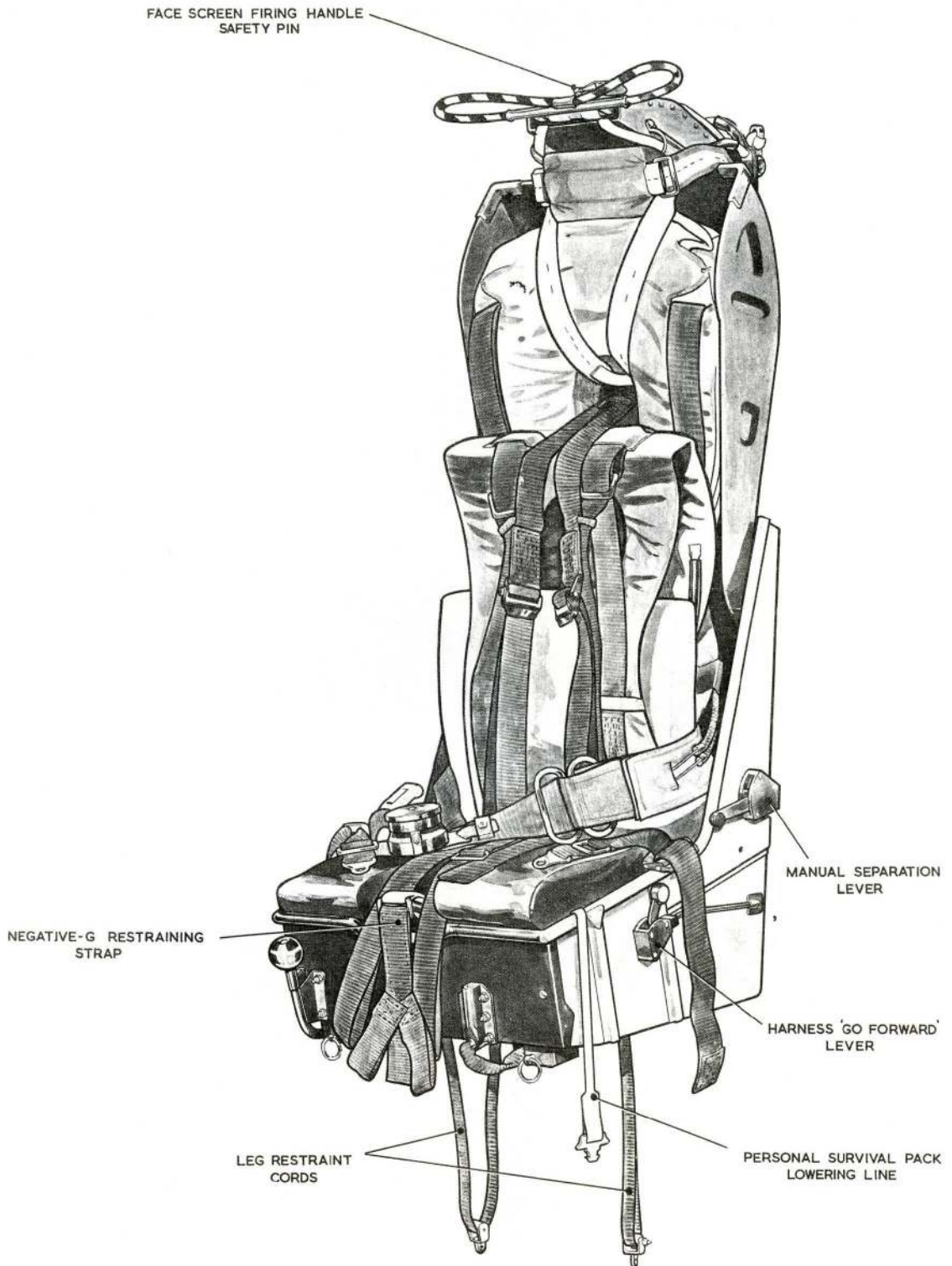

Fig. 5. The seat equipped (port)

RESTRICTED

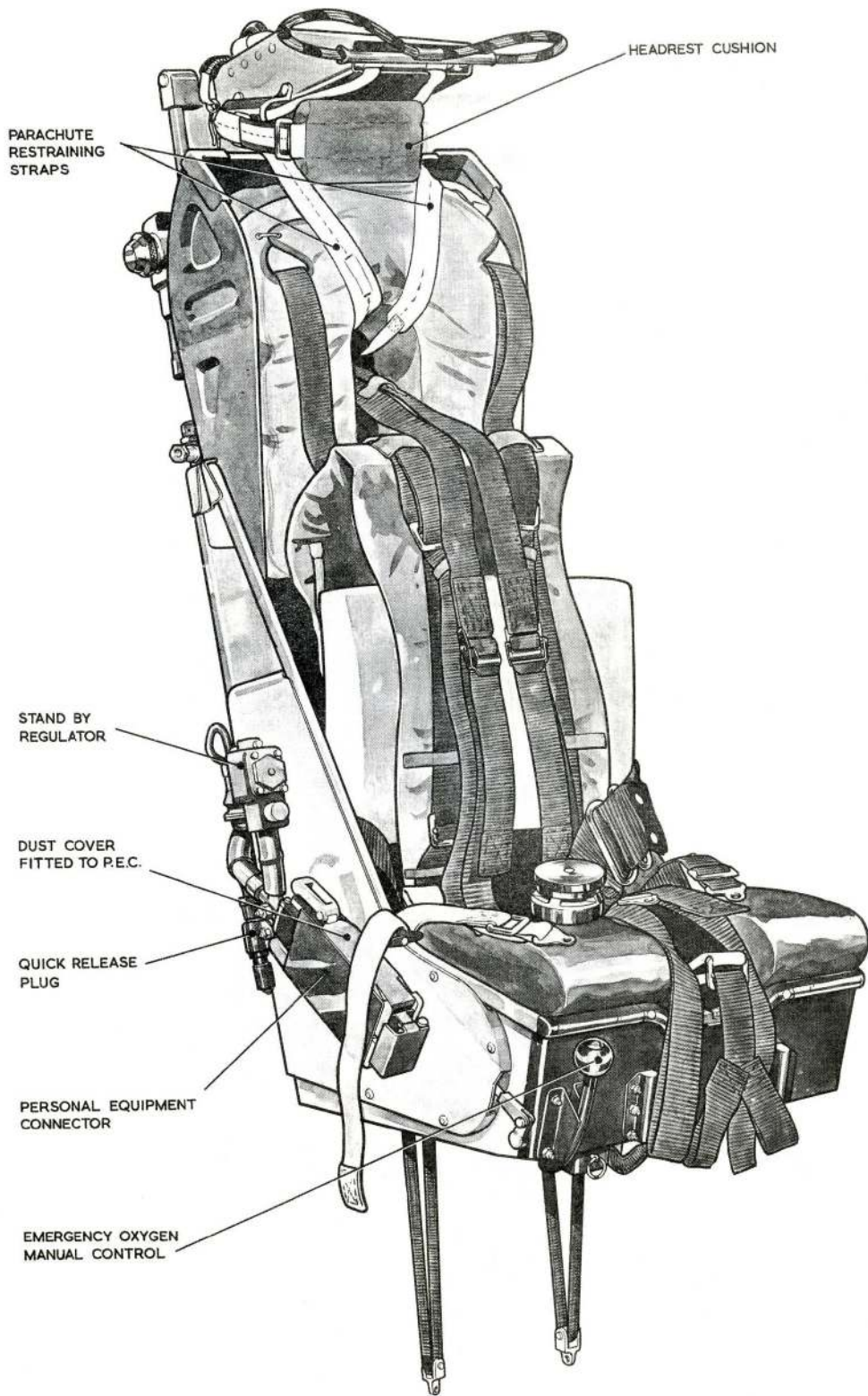

Fig. 6. The seat equipped (starboard)

RESTRICTED

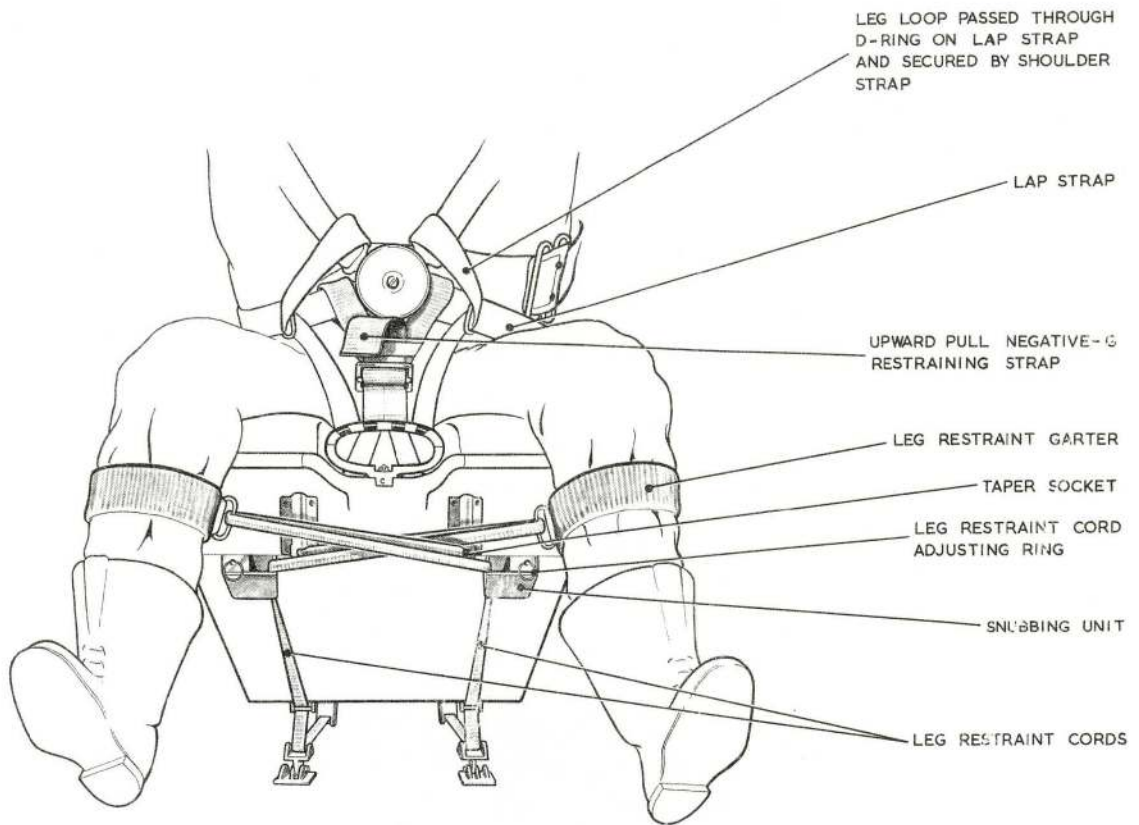

Fig. 7 Arrangement of leg restraint cords and harness : upward pull negative-G restraining strap fitted

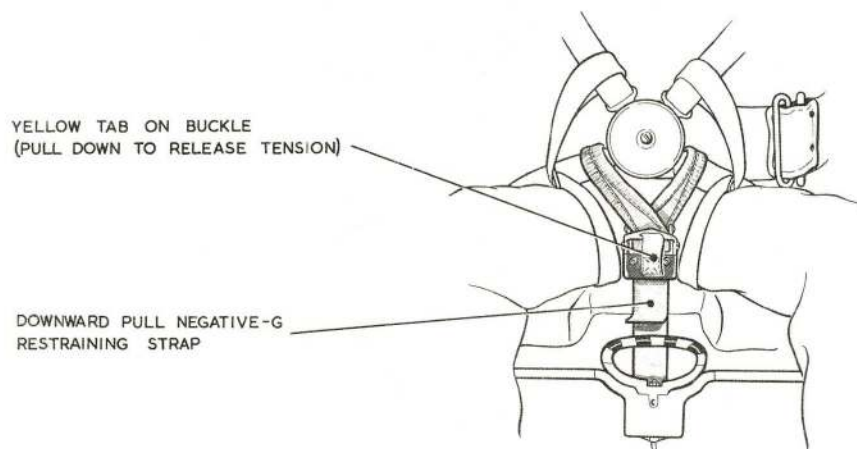

Fig. 8. Arrangement of harness: downward pull negative-G restraining strap is fitted

RESTRICTED

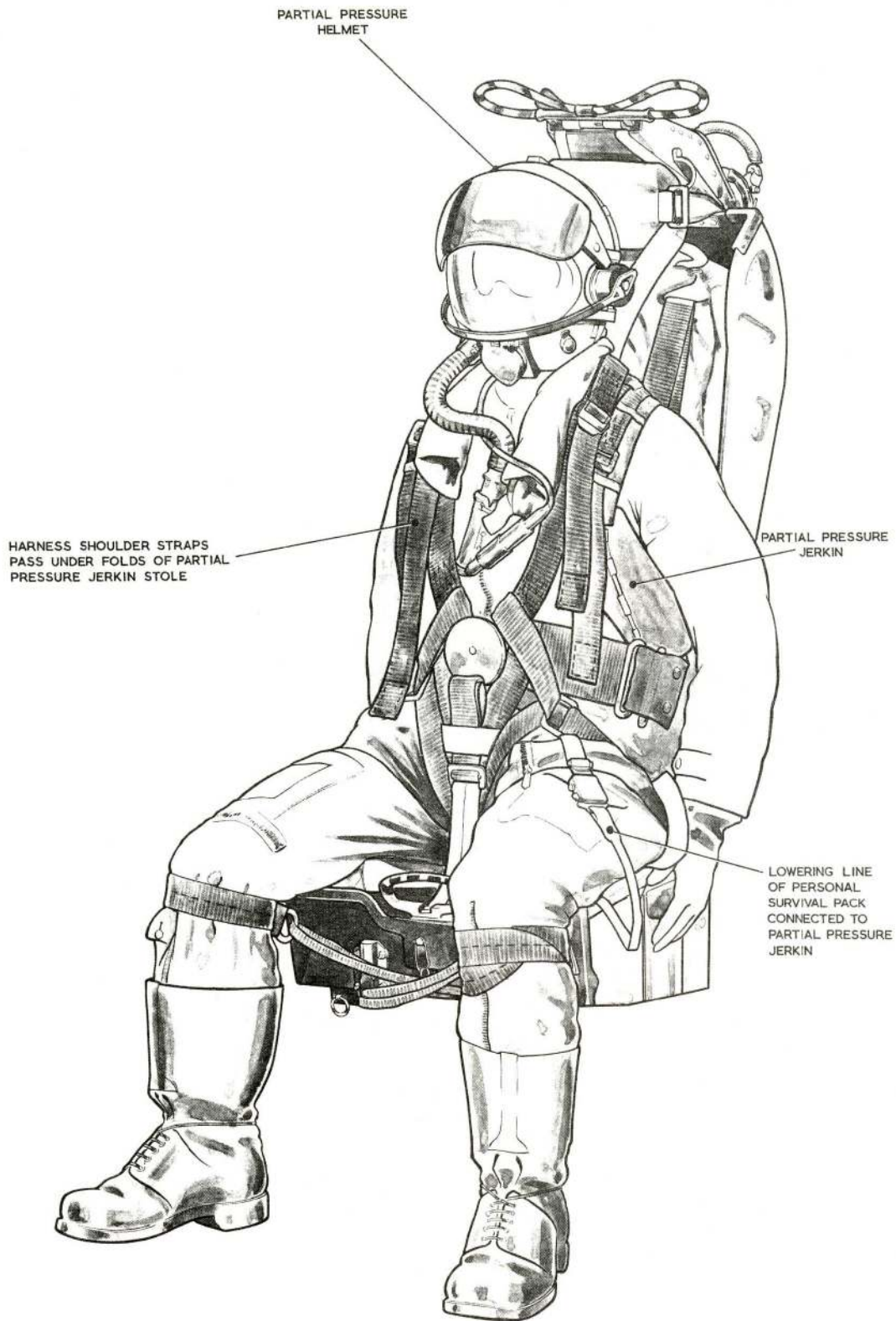

Fig. 9 The seat occupied (port)

RESTRICTED

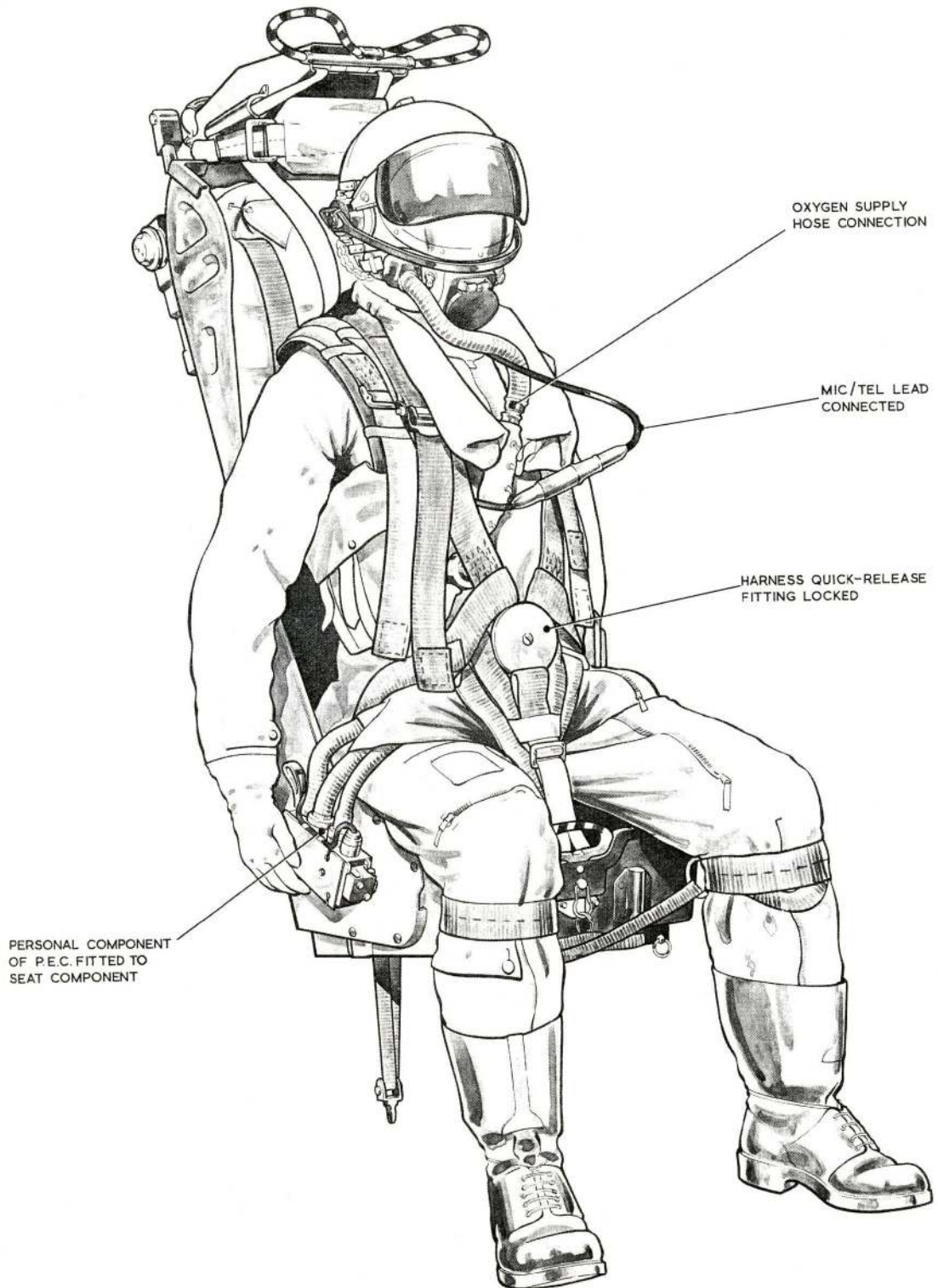
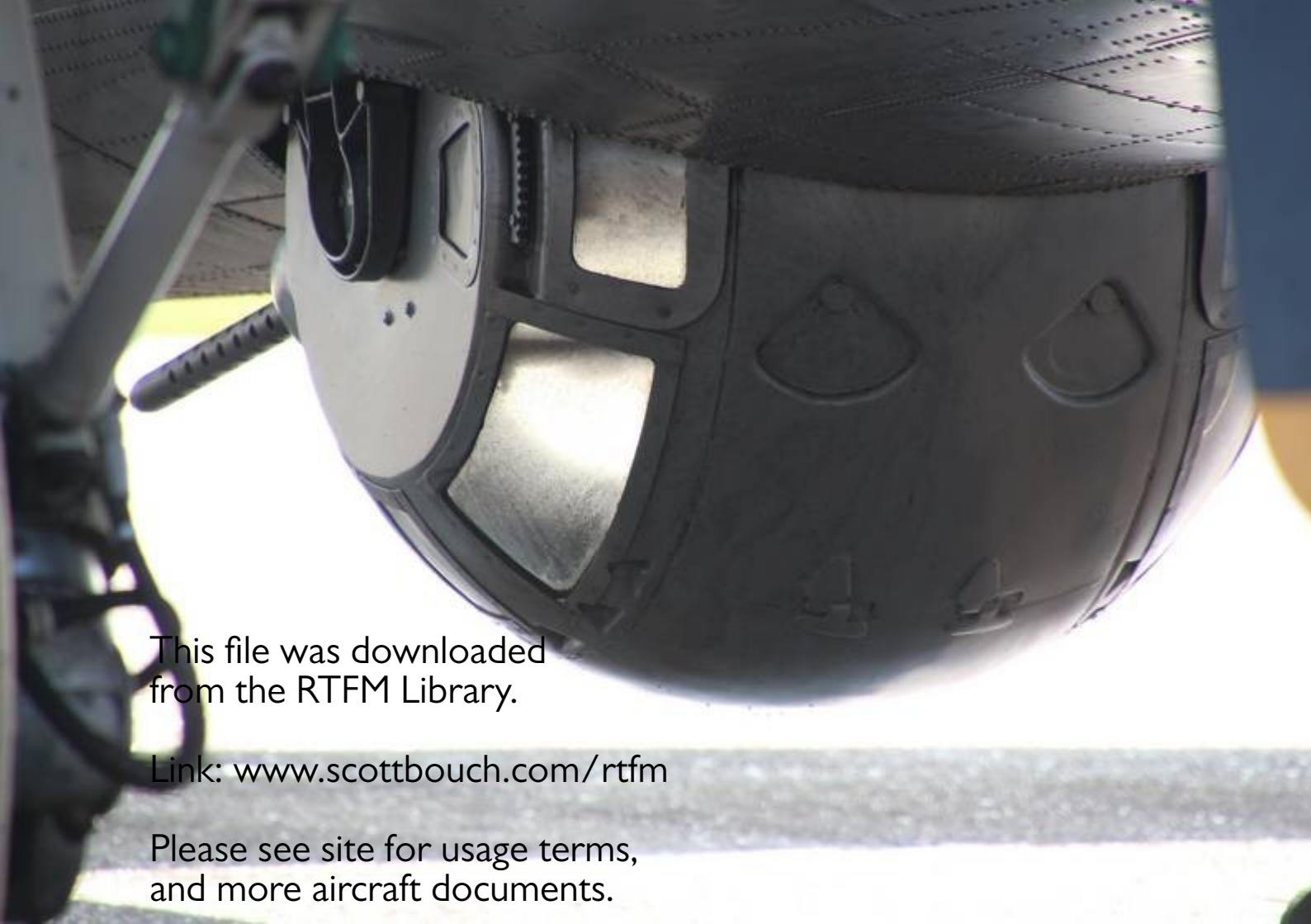

Fig. 10. The seat occupied (starboard)

RESTRICTED



This file was downloaded
from the RTFM Library.

Link: www.scottbouch.com/rtfm

Please see site for usage terms,
and more aircraft documents.