

Chapter 3

RECONNAISSANCE VIEWFINDER FOR CANBERRA PR9

LIST OF CONTENTS

| | <i>Para.</i> | | <i>Para.</i> |
|------------------------------|--------------|--|--------------|
| <i>Introduction</i> | 1 | Installation | 26 |
| Optical system | 8 | Operating instructions | 27 |
| Description | | Servicing | 28 |
| <i>Viewfinder</i> | 12 | ◀ Packaging | |
| <i>Sighting head</i> | 22 | <i>Description</i> | 37 |
| Circuit | 25 | <i>Special packaging instructions</i> | 44 ▶ |

LIST OF ILLUSTRATIONS

| | <i>Fig.</i> | | <i>Fig.</i> |
|---|-------------|--|-------------|
| <i>Diagrammatic optical system</i> | 1 | <i>Exploded view of inside packing case</i> | 5 |
| <i>General arrangement of reconnaissance viewfinder</i> | 2 | <i>Inner packing case with reconnaissance viewfinder</i> | |
| <i>Control box</i> | 3 | <i>in position</i> | 6 ▶ |
| ◀ <i>Photographic view of reconnaissance viewfinder</i> | 4 | <i>Circuit diagram</i> | 7 |

Introduction

1. The reconnaissance viewfinder (Ref. No. 6B/3124) described in this chapter and illustrated in fig. 2 to 4, was specially designed for use in the pressurized cabin of the Canberra PR9 aircraft. It provides an external field of view, and is primarily intended for photographic reconnaissance operations, the operator being enabled to view an area in the flight path, prior to photographing.

2. The instrument consists broadly of a tube assembly (the viewfinder sight) extending upwards and provided, at its lower end, with a sighting head fixed to and standing proud of the aircraft's skin. At the operator's station is an eyepiece assembly as well as a control lever which enables the operator to carry out the desired scanning operations.

3. The instrument includes an optical system having a magnification of 1.2X and a field of view of 40°. It has a scan of 76° forward to include the horizon, and a scan of 64° aft to include the underside of the aircraft.

4. The viewfinder assembly provides an image which is erect both vertically and horizontally, and which remains so throughout the scanned field of view.

5. Maximum light transmission is ensured by the blooming of all optical surfaces.

6. The two exit windows of the sighting head are coated with a transparent conducting medium so that when switched on to the aircraft's a.c. supply, the conducting medium heats the windows sufficiently to prevent the formation of ice and mist.

7. A silica gel type desiccator and a blower motor are incorporated to afford added protection against misting.

OPTICAL SYSTEM

8. The optical system is shown diagrammatically in fig. 1. The external field of view is reflected through the three-component object lens (6) by the rotatable double isosceles scanning prism (7). The object lens forms an inverted image of the index field and this is erected by the two-component erector lenses (4 and 5) and re-imaged just forward of the three-component eyepiece lens (1) after reflection from the mirror (3).

9. The graticule (2, fig. 1) in the present model is engraved with two parallel drift lines 3° apart and with cross lines spaced at 5°, 10°, 15° and 20° each side of the centre line. ◀ A new improved graticule is being introduced (by Mod. Inst. B/205) which includes additional markings for increasing the accuracy of aim in the release of photoflashes. ▶

10. The graticule (2, fig. 1) caters for up to 20° of drift, port or starboard, the movement being controlled by the drift setting knob (22, fig. 3).

11. The prism (7, fig. 1) is connected to the control lever (20, fig. 2) so that the prism may be manually controlled over the scanning range of 140° (i.e., 76° forwards and 64° aft).

DESCRIPTION

Viewfinder

12. The viewfinder illustrated in fig. 2 is fixed to the aircraft by the two lugs (13), and by the connection of the outer end of the lower tube assembly (19) to the sighting head.

RESTRICTED

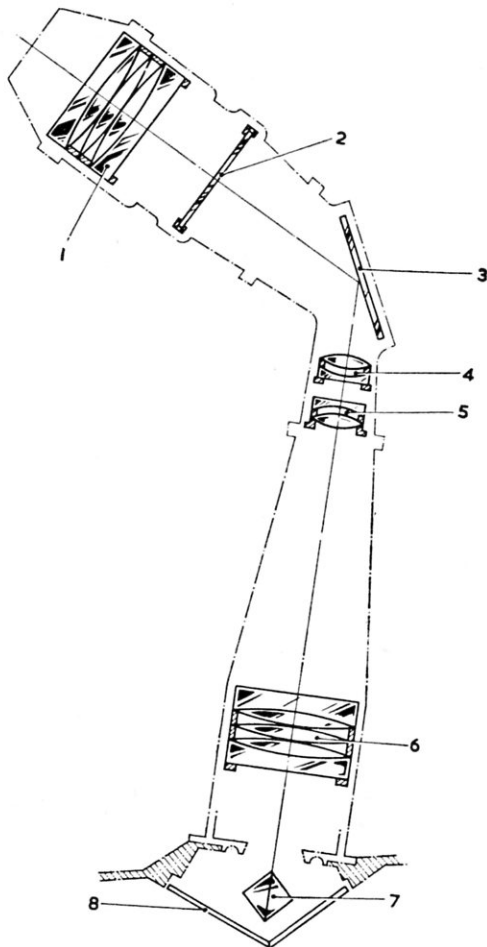

- 1 3-COMPONENT EYEPIECE LENS
- 2 DRIFT GRATICULE
- 3 MIRROR
- 4 2-COMPONENT ERECTOR LENS
- 5 2-COMPONENT OBJECT LENS
- 6 3-COMPONENT OBJECT LENS
- 7 DOUBLE ISOSCELES SCANNING PRISM
- 8 TWO HEATED WINDOWS

Fig. 1. Diagrammatic optical system

13. The viewfinder sight is made up of a series of light alloy castings, and houses the optical system.

14. The lower tube assembly (19, fig. 2) supports the rotatable prism assembly. To rotate the double isosceles prism (7) through its scanning range of 140°, a Teleflex cable (15) and 2:1 reduction gearing, connect up with the scanning control lever (20) which is located on the right-hand side of the mirror box (14), and points in the direction of the line of sight. A metal protective cover (16, fig. 4) houses both the Teleflex cable and the electrical connections from the sighting head.

15. Two spring-loaded roller blinds (18, fig. 2) mounted on the prism casting and extending to two apexes of the prism, exclude any extraneous light from the upward-facing surfaces of the prism at any angle of scan. As the prism is turned by actuation of the control lever, the positions of the two opposite apexes to which one end of each blind is fixed, change; this results in one blind unrolling while the other rolls up.

16. The spring-catch lever (21, fig. 3) locks the control lever (20) in one or other of the following two fixed positions:—(1) When the line of sight is normal to the aircraft flight datum and (2) when the line of sight is 40° forward from the normal to the aircraft flight datum.

17. Secured to the mirror box (14, fig. 2) is the viewing lens housing (10) attached to which is the rubber eyepiece guard (9). ◀ The assembly 9a to 9d has been added by Mod. Inst. B/206 to provide an improved means of eye location. The rigid metal hood (9b) is held to the guard (9) by the fastener (9a), and the single density shade (9c) and the rubber eyeguard (9d) are both arranged so as to hinge out of the line of sight when not required. ▶

18. Mounted on the viewing lens housing is the control box (fig. 3) whose panel carries the under-mentioned controls:—

(1) Switch (S1) — marked LAMPS — for controlling the illumination of the drift scale and the graticule. This 3-way switch permits the drift scale lamp LP1 and the two graticule lamps LP2-3 (fig. 4) to be BRIGHT, OFF or DIM.

(2) Switch (S2) — marked HEATER — for switching the two window heaters ON or OFF. A half-hood on the switch is provided to prevent the toggle switch from being accidentally knocked to OFF, since it is important that the the window heating should remain ON during flight.

(3) Control (RV1) — marked SCALE DIM — for controlling the intensity of illumination of the drift scale.

(4) Control (RV2) — marked GRATICULE DIM — for controlling the intensity of illumination of the graticule.

(5) Knob (22) — marked DRIFT — for setting the indication of drift. The amount of drift is indicated on the scale (23) on the left of the control box, against a fixed datum.

19. The 6-pole, Mk. 4 miniature plug (PL1, fig. 2) located on the underside of the control box (12) receives the electrical supplies from the sighting head.

20. The silica gel type desiccator (25, fig. 4) is clipped onto the viewfinder and affords added protection against misting.

21. De-misting is improved by the use of a blower motor (M1, fig. 4) — introduced by a pre-production Mod.— which is fixed to the side of the lower tube assembly and which forces air through the silica gel desiccator.

Sighting head

22. The sighting head (fig. 2) which is pressure-tested to 20 lb/in² consists of a casting (17) incorporating two glass windows (8) set in a synthetic rubber gasket and arranged in a shallow V formation.

23. The two exit windows (8) of the sighting head are coated on their inner surfaces with a film of electrically-conductive material, coupled up to the 115V, a.c. aircraft's supply. When the supply is

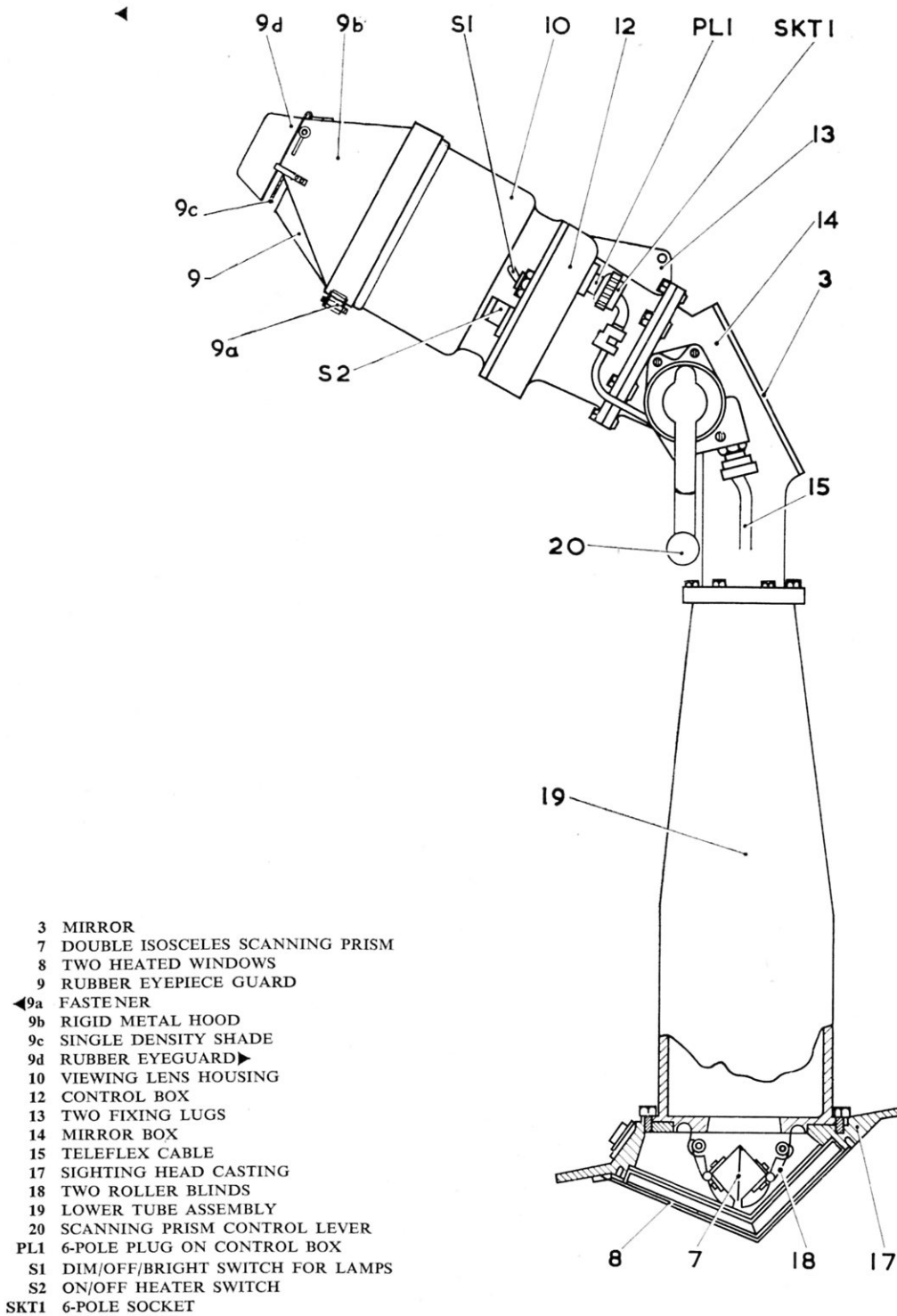
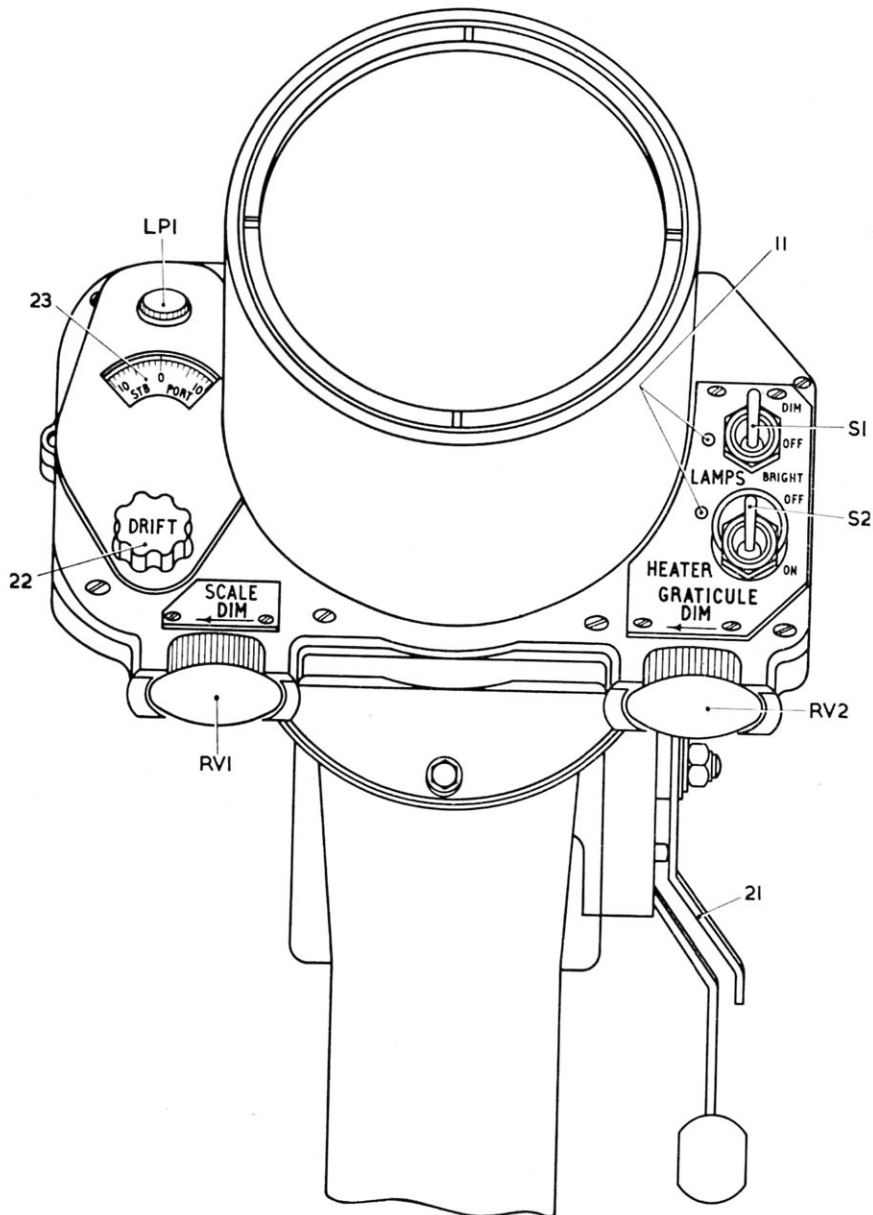

Fig. 2. General arrangement of reconnaissance viewfinder

RESTRICTED



- 11 GRATICULE LAMP INDICATORS
- 21 SPRING-CATCH LOCKING LEVER
- 22 DRIFT SCALE KNOB
- 23 DRIFT SCALE
- LPI DRIFT SCALE LAMP

- RV1 DRIFT SCALE DIMMER CONTROL
- RV2 GRATICULE DIMMER CONTROL
- S1 DIM/OFF/BRIGHT SWITCH FOR LAMPS
- S2 ON/OFF HEATER SWITCH

Fig. 3. Control box

switched on by means of the switch (S2), the conducting medium heats the windows sufficiently to prevent the formation of ice and mist. This heating is controlled by a bi-metallic strip type, thermostat (S3, fig. 4) in the sighting head, set to maintain an ambient temperature of $48^{\circ} \pm 3^{\circ}\text{C}$.

Note . . .

The control switch should be put ON at take-off and left ON during the flight.

24. At the rear of the sighting head above the skin line of the aircraft, are located a Mk. 4 miniature plug (PL3, fig. 4) and a Mk. 4 miniature socket (SKT2). The plug receives the input of the

28V d.c. for graticule and scale lighting, and the input of the 115V a.c. 400 c/s for the heaters and the motor; the socket is connected through a cable to the control box (12, fig. 2) forming part of the viewfinder sight.

CIRCUIT

25. The circuit for the reconnaissance viewfinder is given in fig. 7. The aircraft's a.c. and d.c. supplies are connected to the 4-pole plug (PL3) which feeds a.c. to the heaters and to the 3-phase blower motor (M1). Plug (PL3) also feeds the aircraft's d.c. supply to the drift scale lamp (LP1) and to the two graticule lamps (LP2 and LP3), their intensities of

RESTRICTED

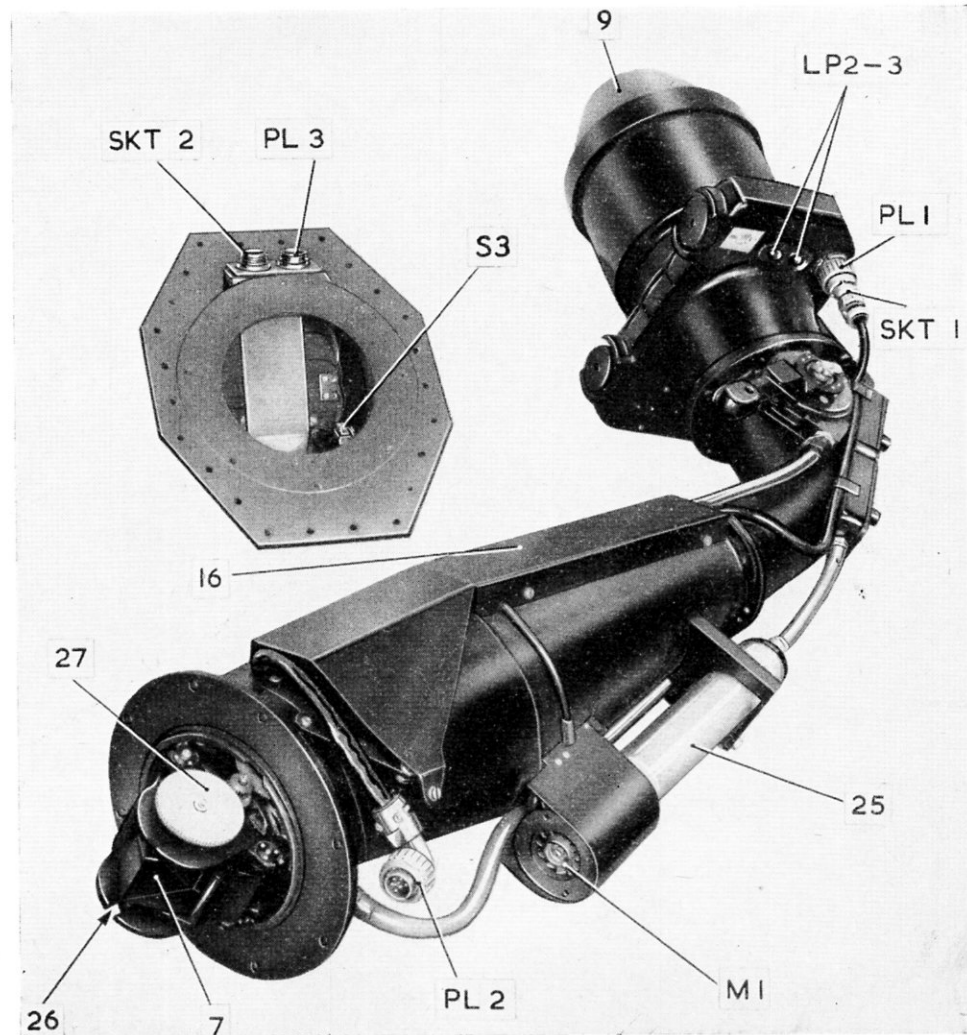

- | | | | |
|-------|--|------|--|
| 7 | DOUBLE-ISOSCELES SCANNING PRISM | M1 | BLOWER MOTOR |
| 9 | RUBBER EYEPiece GUARD | PL1 | 6-POLE PLUG ON CONTROL BOX |
| 16 | METAL PROTECTIVE COVER | PL2 | 6-POLE FREE PLUG TO SKT2 |
| 25 | SILICA GEL DESICCATOR | PL3 | 4-POLE SOCKET RECEIVING 28V d.c. AND 115V a.c. |
| 26 | PRISM RETURN SPRING | S3 | THERMOSTAT |
| 27 | GEARING BETWEEN PRISM AND TELEFLEX CABLE | SKT1 | 6-POLE SOCKET |
| LP2-3 | TWO GRATICULE LAMPS | SKT2 | 6-POLE SOCKET TO PL2 |

Fig. 4. Photographic view of reconnaissance viewfinder

illumination being varied by the resistors (R1, RV1 and RV2).

INSTALLATION

26. The prism assembly is provided with a temporary metal protective cover which is removed when the lower tube assembly (19, fig. 2) is secured to the sighting head. To avoid damage, care must be taken to see that the bolt holes of the sighting head and of the lower tube assembly coincide as the latter is brought into position.

OPERATING INSTRUCTIONS

27. The following operating instructions should be carried out:—

(1) The window heaters must be switched ON, before flight commences, by means of the switch (S2, fig. 3) marked HEATER;

(2) The drift scale and graticule lamps should, if necessary, be switched on by the 3-way switch (S1), either to BRIGHT or DIM, and adjusted to the required intensity of illumination by the knobs (RV1 and RV2);

(3) The drift angle should be set by turning the drift scale knob (22); and

(4) The required line of sight of the prism should be obtained by means of the scanning control lever (20, fig. 2).

RESTRICTED

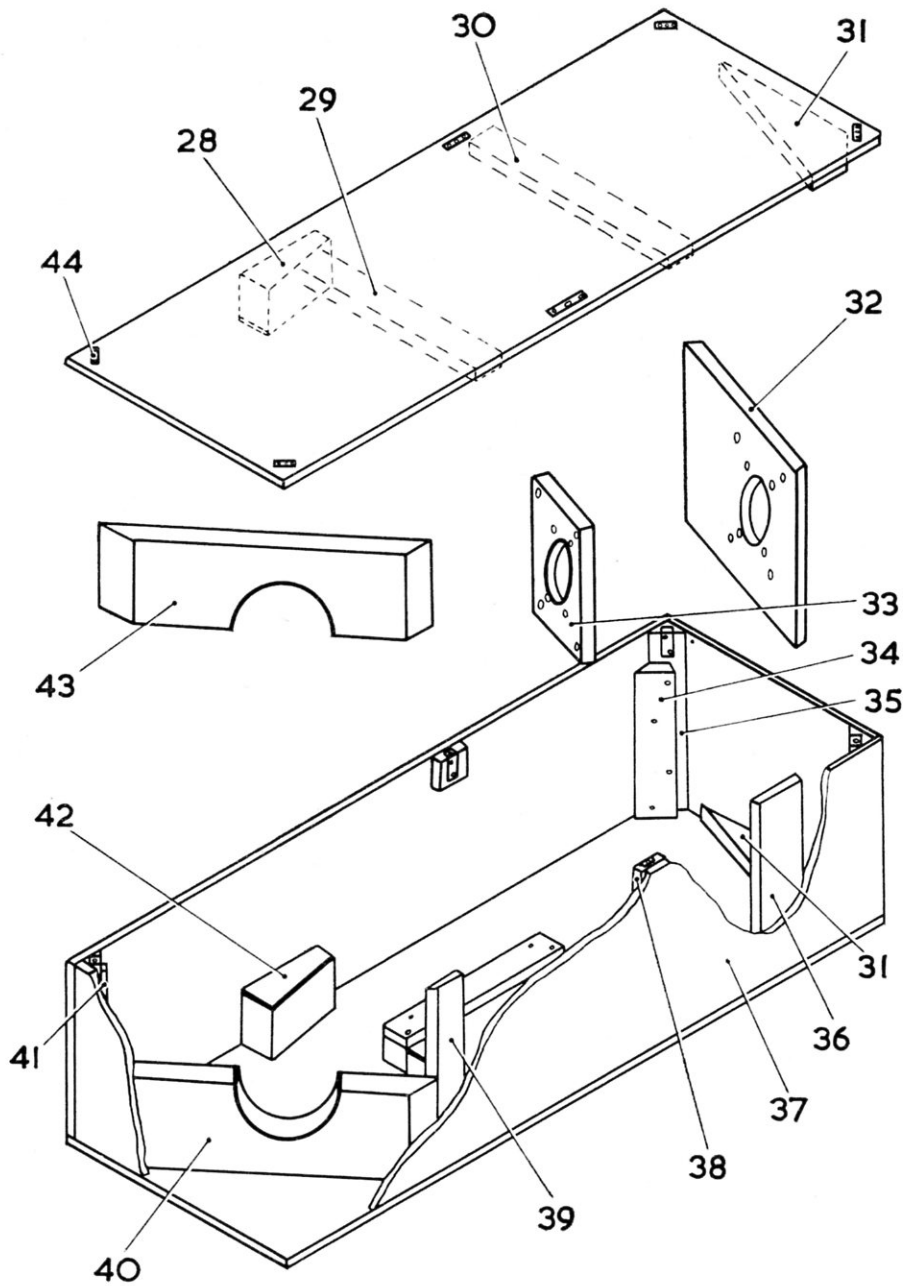

- 28 SOFTWOOD SUPPORT BLOCK AND $\frac{1}{8}$ in. FELT
- 29 } SOFTWOOD BATTENS
- 30 } SOFTWOOD BATTENS
- 31 SOFTWOOD SUPPORT BLOCK
- 32 } PLYWOOD SUPPORT BLOCKS
- 33 } PLYWOOD SUPPORT BLOCKS
- 34 SOFTWOOD SUPPORT BLOCKS
- 35 SOFTWOOD CORNERS
- 36 PLYWOOD SUPPORT BLOCK

- 37 PLYWOOD CASE
- 38 SOFTWOOD SUPPORT BLOCK
- 39 PLYWOOD SUPPORT BLOCKS
- 40 SOFTWOOD SUPPORT BLOCK AND $\frac{1}{8}$ in. FELT
- 41 PLYWOOD SUPPORT BLOCK
- 42 } SOFTWOOD SUPPORT BLOCKS AND $\frac{1}{8}$ in. FELT
- 43 } SOFTWOOD SUPPORT BLOCKS AND $\frac{1}{8}$ in. FELT
- 44 CAPTIVE SCREW FITTINGS

Fig. 5. Exploded view of inside packing case

RESTRICTED

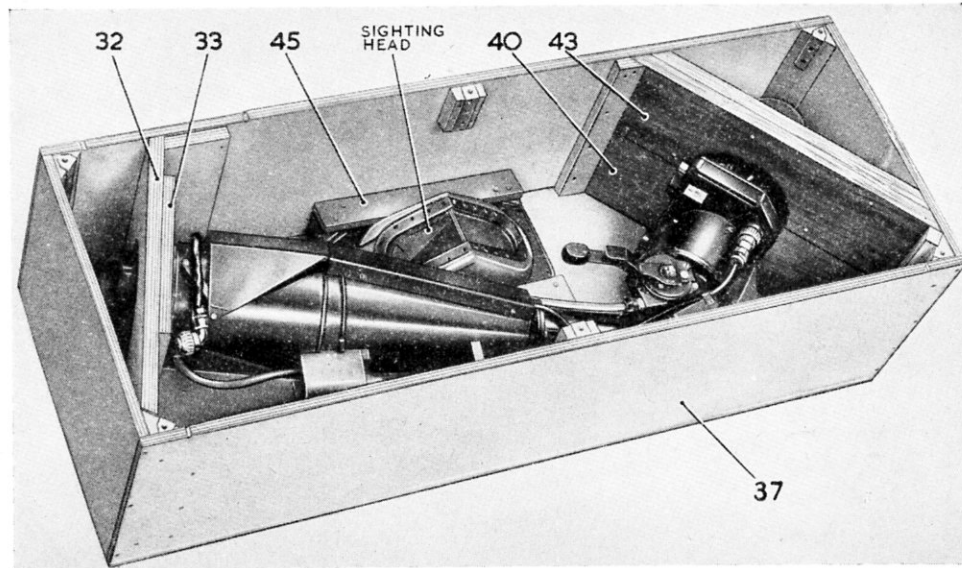

32 } PLYWOOD SUPPORT BLOCKS
33 }
37 PLYWOOD CASE

40 } SOFTWOOD SUPPORT BLOCKS AND $\frac{1}{8}$ in. FELT
43 }
45 TWO PLYWOOD SECURING BLOCKS FOR SIGHTING HEAD

Fig. 6. Inner packing case with reconnaissance viewfinder in position

SERVICING

28. The equipment being desiccated, no attempt should be made to dismantle it for cleaning purposes.

29. The serviceability of the instrument may be confirmed as follows.

30. Check visually for signs of damage, security of mounting, etc., and ensure that all mechanical and electrical components are functioning correctly.

31. Should one of the graticule lamps fail to operate, it will be noticed by the absence of light from its indicator (11, fig. 3), and the lamp may be removed for inspection. The drift graticule lamp holders (LP2-3, fig. 4) are located on the underside of the panel of the control box, and the drift scale lamp (LP1, fig. 3) will be found above the drift scale (23).

32. The scanning control lever and the spring-catch locking lever should be operated to ensure freedom of movement.

33. The window heaters should be switched on and it should be checked, by feel, that both are working.

34. Check that the sighting head windows and the eyepiece lens in the eyepiece tube, are unbroken and free from grease, dirt and other foreign matter. It is recommended that these optical items should be cleaned with pure spirit using a grease-free anti-static polishing cloth (Ref. No. 14B/3599).

35. Check the silica gel in the desiccator for discoloration and, if necessary, renew.

36. Unserviceable items are to be dealt with in accordance with current Service instructions.

◀ PACKAGING

Description

37. Packaging of the reconnaissance viewfinder consists broadly in packing the instrument in an inner case which is floated between pads of rubberized hair cemented by Bostik to the inside faces of an outer container.

38. The inner and outer cases are provided with lids, are of plywood and have internal dimensions of $44\frac{1}{4}$ in. \times $15\frac{1}{2}$ in. \times $11\frac{1}{2}$ in. and $51\frac{3}{4}$ in. \times $22\frac{1}{2}$ in. \times $18\frac{1}{2}$ in. respectively.

39. Fig. 5 represents an exploded view of the inner packing case and fig. 6 shows the instrument in its stowed position. The outer case is not shown in the illustrations.

40. The inner case (fig. 5) is in the form of a box with a lid secured by six sets of captive screw fittings, and the inside contains various wooden members used for supporting and retaining the instrument.

41. The sighting head is held by the two plywood securing blocks (45, fig. 6) and the ends of the viewfinder sight are retained, one by the plywood support blocks (32 and 33) and the other, by the softwood support blocks (40 and 43).

42. The plywood outer case includes a lid with eight sets of captive screw fittings, three at each side and one at each end. The top, base, two sides and two ends of the case have cemented to their inside

RESTRICTED

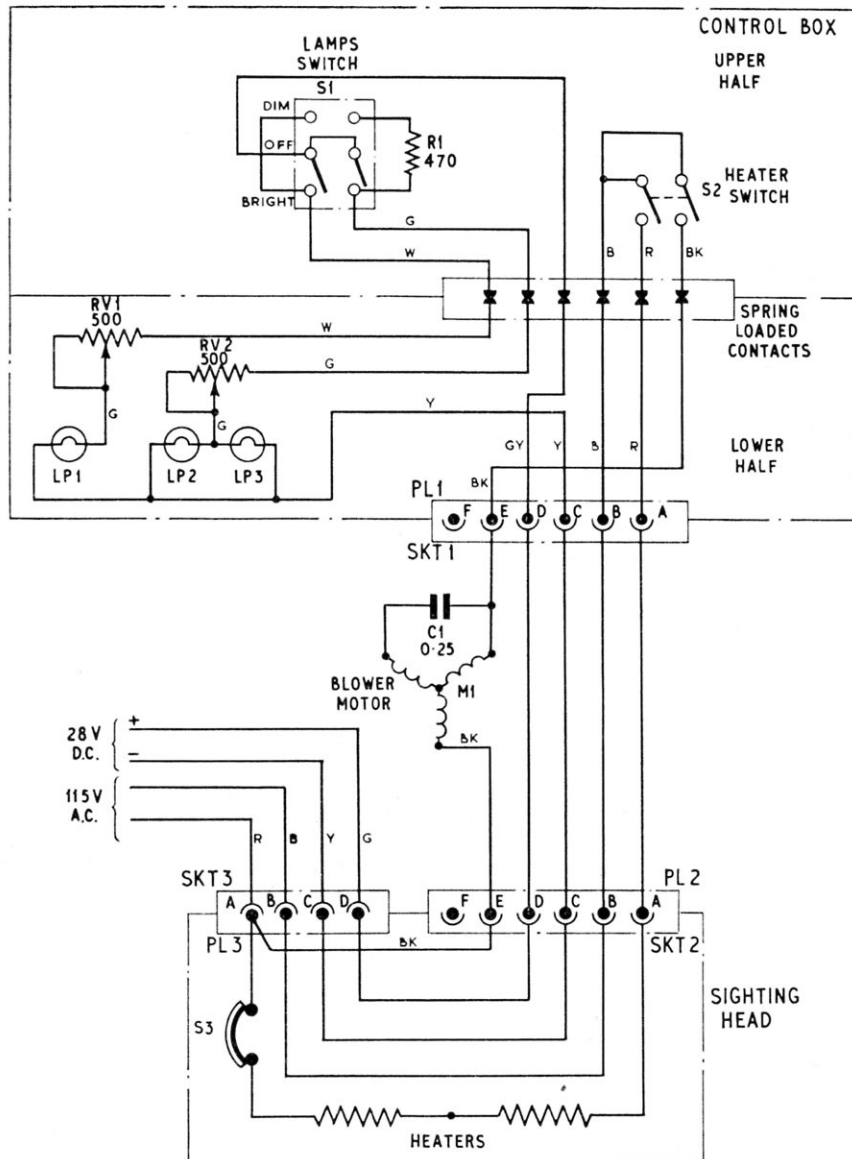

Fig. 7. Circuit diagram

faces, pads of 3 in. thick rubberized hair between which the inside case is floated. The two end pads each have a $\frac{1}{4}$ in. thick plywood pressure plate affixed by Bostik to their inside walls.

43. The actual packing of the instrument, the wrapping and the inclusion of a desiccant, are dealt with in the instructions in the following para. 44 to 53.

Special packaging instructions

44. Secure the plywood support block (33, fig. 5) to the flange on the instrument with the four $1\frac{1}{2}$ in. long screws, nuts and washers provided.

45. Wrap the free plug PL2 (fig. 4) and its cable in four thicknesses of polyvinyl chloride film (B.S.1763) and secure with tape, waterproof, transparent (C.S.2501).

46. Wrap the instrument in paper, wrapping, waxed, DEF.1242.

47. Place the wrapped instrument together with 3 lb of desiccant, wrapped in polyvinyl chloride film (B.S.1763), into a polythene envelope 50 in. \times 20 in. \times 0.020 in. thick (C.S.2596). Extract all excess air before sealing to DEF.1234, Part 2, Sect. 4.

48. Secure the instrument to the plywood support block (32) by puncturing the polythene envelope, through the outer holes of the plywood support block (33) and, using the four $2\frac{1}{2}$ in. long screws, the nuts, the steel washers and the red fibre washers provided, screw on the block (32).

49. Wrap the sighting head in paper, wrapping, waxed, DEF.1242.

RESTRICTED

50. Place the wrapped component together with 12 oz of desiccant, wrapped in polyvinyl chloride film (B.S.1763), into a polythene envelope 18 in. × 15 in. × 0.020 in. thick (C.S.2596). Extract all excess air before sealing to DEF.1234, Part 2, Sect. 4.

51. Locate the sealed sighting head into the inner container.

52. Locate the instrument into the inner container and place the softwood support block (43) in position. Close the lid and secure with the captive fittings.

53. Float the inner container into the outer container and secure the lid with the captive fittings, three either side and one at each end. ►

RESTRICTED

This file was downloaded
from the RTFM Library.

Link: www.scottbouch.com/rtfm

Please see site for usage terms,
and more aircraft documents.

