

THE FOUR-STROKE CYCLE, TIMING AND COOLING

Introduction

1. As most readers will have some interest in and elementary knowledge of the internal combustion engines of cars or motorcycles, this chapter is intended to provide a stepping stone to the more detailed and technical descriptions of aero-engines given in the official handbooks. As such, it does not attempt to explore, for example, all the different types of carburettor, or the subject of engine materials, but rather to give the pilot a grasp of the working principles (and problems) of the more important sections of an aero-engine.

2. For further reading, apart from the handbooks already mentioned, attention is particularly drawn to the chapter on "Engine Handling".

The Four-Stroke Cycle

3. The internal combustion piston engine con-

sists basically of a cylinder (Fig. 1) which is closed at one end, a piston which slides up and down inside the cylinder, and a connecting rod and crank by which reciprocating movement of the piston is converted to rotary movement of the crankshaft. In the closed end of the cylinder, known as the cylinder head, are inlet and exhaust valves and a sparking plug.

4. The sequence of operations by which the engine converts heat energy into mechanical energy is known as the four-stroke cycle. A mixture of petrol and air is introduced into the cylinder during the induction stroke, and compressed during the compression stroke. At this point the fuel is ignited, the heat generated causing a rapid increase in pressure which drives the piston down on its power stroke. Finally, the waste products of combustion are ejected during the exhaust stroke.

- 1. CYLINDER
- 2. CYLINDER HEAD
- 3. PISTON
- 4. PISTON RINGS
- 5. CONNECTING ROD
- 6. GUDGEON PIN
- 7. SMALL-END BEARING
- 8. BIG-END BEARING
- 9. CRANKPIN
- 10. CRANK
- 11. CRANKSHAFT
- 12. MAIN BEARING
- 13. EXHAUST VALVE
- 14. CAM
- 15. TAPPET
- 16. PUSH ROD
- 17. VALVE ROCKER
- 18. VALVE SPRING
- 19. SPRING CAP
- 20. INLET VALVE
- 21. VALVE GUIDE
- 22. SPARKING PLUG
- 23. MAGNETO
- 24. CRANKCASE

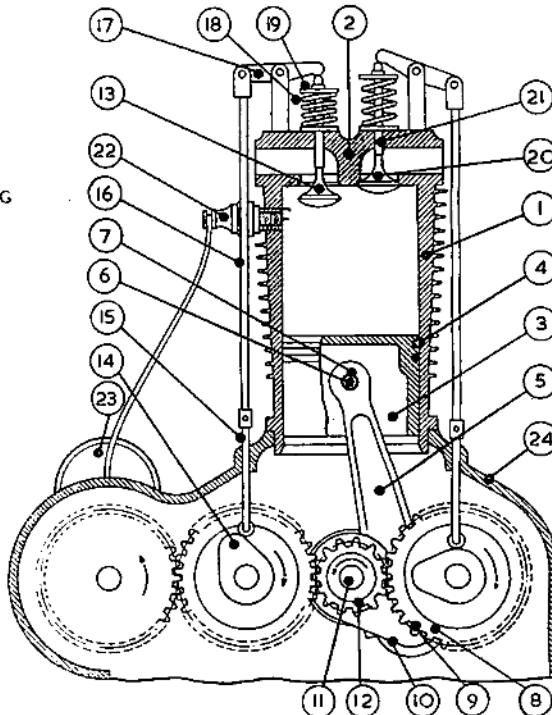

Fig. 1. A Four-Stroke Internal Combustion Engine.

RESTRICTED

A.P. 129, VOL. 1, PART 1, SECT. 2, CHAP. 1

5. **Induction Stroke.** On the induction stroke, throughout which the inlet valve is open, the piston (Fig. 2) descends in the cylinder and thereby lowers the pressure, so that the mixture of petrol and vapour and air is forced in by the pressure outside. Because of its inertia the flow of gas tends to lag, an effect which is aggravated by the resistance of the induction passages through which the gas has to travel before reaching the cylinder. As the power output of the engine depends on the weight of gas which can get in during the short period ($\frac{1}{1000}$ second or less at normal speeds) of the induction stroke, these passages must be free from sharp bends or constrictions, intentional reduction of power being obtained by means of a variable obstruction known as the throttle. However well the induction system is designed it is not possible to fill the cylinder quite up to the same pressure as exists outside, and the ratio of the weight of gas in the cylinder at the end of the induction stroke to that which would be there if there were no resistance or inertia is called the volumetric efficiency of the engine.

6. **Compression Stroke.** As the piston (Fig. 2) moves upwards, the inlet valve closes and the gas is compressed. By squeezing the gas into a

smaller space the pressure it exerts when burnt is proportionately increased. The ratio of its volume at bottom dead centre (B.D.C.), *i.e.* when the piston is at its lowest point of travel in the cylinder, to that at top dead centre (T.D.C.) is known as the compression ratio, which in aero-engines is usually in the region of 6 to 1. It should be noted that the compression ratio is a ratio of volumes and is not a measure of the increase of pressure in the cylinder; as the gas is compressed it becomes heated adiabatically—in the same way that a bicycle pump warms up in action—as well as by conduction from its hot surroundings, and the pressure consequently rises to a higher value than that to be expected from the reduction in volume alone.

7. **Power Stroke.** Just before the piston reaches T.D.C. on the compression stroke the gas is ignited by a spark (Fig. 2). As the flame spreads through the combustion chamber the intense heat raises the pressure rapidly to a peak value which is reached when the piston is about 10° past T.D.C. The gas continues to burn and its pressure falls as the piston is forced down until, towards the end of the power stroke, combustion is complete and the pressure on the piston is comparatively small.

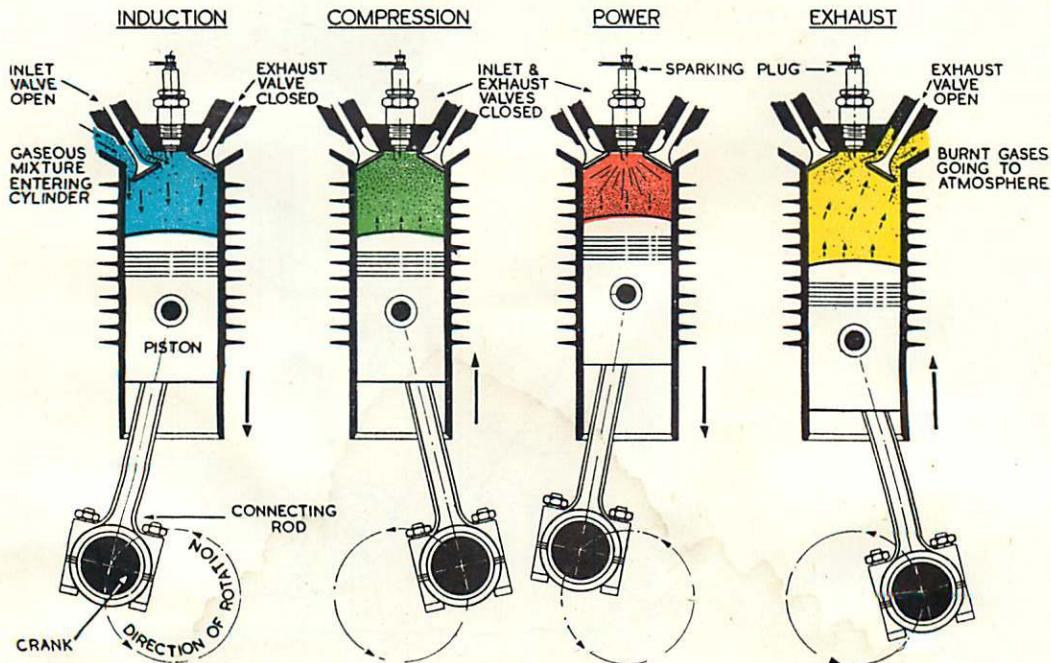

Fig. 2. The Four-Stroke Cycle.

RESTRICTED

(A.L. 2, Jan. '55)

RESTRICTED

THE FOUR-STROKE CYCLE, TIMING AND COOLING

8. **Exhaust Stroke.** With the exhaust valve open, the piston ascends, forcing out the spent gases (Fig. 2). Here again it is important that the flow should be as free as possible, for not only would an obstruction cause a back pressure to be exerted on the piston, but it would also result in an undesirable amount of burnt gas remaining in the cylinder and so contaminating the fresh charge. At the end of the exhaust stroke the exhaust valve closes, the inlet valve opens, and the cycle begins again.

9. One of the most noticeable differences between car and aero-engines is that, with the exception of those fitted to light aircraft, the latter possess more cylinders. This is because it is impracticable, for various reasons, to obtain much more than 100 B.H.P. per cylinder; consequently a high output would not be developed by a scaled-up version of a low-power engine.

10. Even in engines of modest power it is often better to use a number of small cylinders in preference to fewer and larger, for not only does smoother operation result, but also, in many cases, a smaller frontal area can be obtained.

Timing

11. There is a limit to the speed at which the valves can be made to open and close, beyond which excessive stresses will be imposed on the valve operating gear. Moreover, while the valve is nearly closed not much gas can get through and, in order not to waste any part of the induction and exhaust strokes, the valves begin to open earlier, and finally close later, than might at first be expected (Fig. 3). The closing point of the inlet valve is further delayed because the inertia of the incoming gas causes the flow to continue until well after B.D.C. This lag in

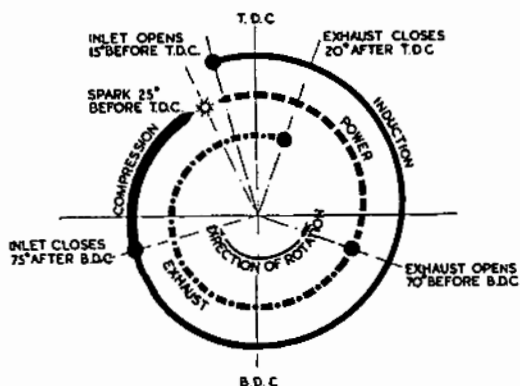

Fig. 3. Typical Timing Diagram.

closing enables a bigger charge to enter, and thus increases the volumetric efficiency. The opening of the exhaust valve is considerably advanced because any pressure remaining in the cylinder after B.D.C. opposes the upward movement of the piston, and the valve must be opened in time for the pressure to drop to nearly atmospheric at B.D.C. At the end of the exhaust stroke the inertia of the burnt gas helps to evacuate the combustion chamber more completely where the closing of the exhaust valve is delayed. If the inlet valve is opened early, so that there is a certain amount of valve overlap, the reduced pressure due to the rapid exit of the exhaust gases encourages the fresh charge to enter.

12. The factors affecting valve timing increase with the rotational speed of the engine; consequently, in high-speed engines, valve lead, lag, and overlap are considerable.

13. As engine speed is increased it is necessary for the spark to be further advanced (*i.e.* to be made to occur at a greater crank angle before T.D.C.) so that the maximum combustion pressure will still occur early in the power stroke. However, rich mixtures, such as are necessary when an engine is developing its full power, burn faster than normal or weak mixtures, and consequently it is usual for the spark to be slightly retarded at full throttle.

Cooling

14. If an engine were perfectly efficient all the heat produced in it would be turned into useful work, and the problem of cooling would not arise. This is impossible, however, and in practice less than 30 per cent. of the heat generated during combustion is converted into mechanical energy; about 40 per cent. passes out with the exhaust gases, while the remainder finds its way into the engine and, if no steps were taken to get rid of it, would cause mechanical deterioration and burning of the oil.

15. Not only must the average temperature be kept down but local hot spots must also be avoided so that distortion due to differential expansion is minimized. It is comparatively easy to deal with cylinders, which are in direct contact with the cooling medium, but components such as pistons, valves, and sparking plugs, can only be directly cooled and special attention has to be paid to them to avoid local overheating. Pistons dissipate their heat by conduction to the cylinder walls and are, consequently, made of a

highly conductive metal. Inlet valves are cooled by the incoming mixture, but the exhaust valves are exposed to the spent gases and usually operate at red heat. To keep the temperature down, the stems of exhaust valves are made hollow (see Fig. 4) and partly filled with sodium; at normal working temperatures the sodium melts and, as it is thrown from one end of the stem to the other, carries heat quickly away from the valve head.

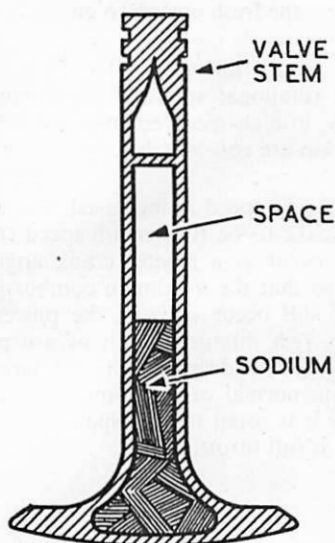

Fig. 4. Sodium-Cooled Exhaust Valve.

16. There are two methods of cooling the cylinders, air cooling and liquid cooling, the difference being that in one case heat is transferred directly to the air through which the engine moves, whereas in the other a liquid coolant circulates continuously between the cylinders and a radiator. Each system has its merits, and each tends, though not exclusively, to a distinctive arrangement of the cylinders.

17. **Air Cooling.** To increase the heat dissipation air-cooled cylinders are encircled by deep fins, and baffles are sometimes fitted to guide the airflow more evenly around the cylinders. The radial engine (Fig. 5), in which the cylinders are evenly spaced around the crankcase, is particularly suited to this method of cooling as each cylinder is directly in the path of the propeller slipstream. Such engines have an odd number of cylinders, so that an even firing sequence is possible, with one crank and a master connecting rod to which the other connecting rods are attached. If a more powerful radial engine is required than can be obtained by increasing the number of cylinders around the one crank, two engines are, in effect, joined. In this type—the double-banked radial engine—the two cranks are set 180° apart. Although air-cooled engines are simpler than liquid-cooled ones and are free from the extra weight of coolant, radiators, pumps, and associated piping, the comparatively large frontal area of the radial type is a disadvantage which has been only partially overcome by compact design and efficient cowling. For moderate and low power outputs, however, where the amount of heat to be dissipated is not excessive, the lower frontal area of an in-line cylinder arrangement can be obtained. In these cases baffling, as previously mentioned, is desirable.

RESTRICTED

THE FOUR-STROKE CYCLE, TIMING AND COOLING

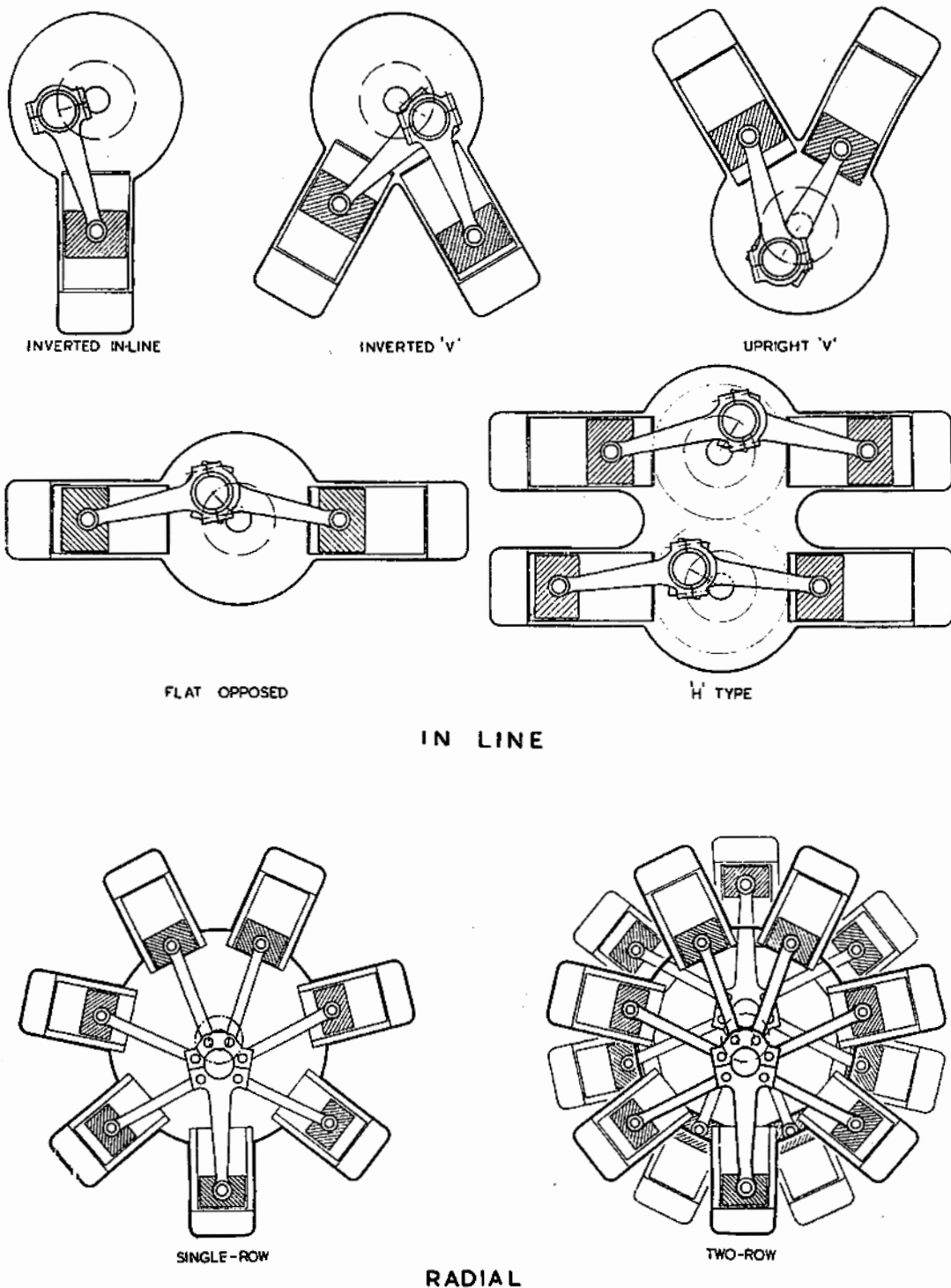

Fig. 5. Typical Cylinder Arrangements.

RESTRICTED

A.P. 129, VOL. 1, PART 1, SECT. 2, CHAP. 1

18. **Liquid Cooling.** In liquid-cooled engines (Fig. 6) the coolant—usually a mixture of water and ethylene glycol—is circulated by a pump through jackets surrounding the cylinders, and then through the radiator. By careful design of the coolant passages, the flow can be controlled so as to ensure more even cooling than is possible in air-cooled engines, thus making it possible for more power to be obtained for a given cylinder size. Ethylene glycol, either pure or diluted, has a lower freezing and a higher boiling point than water, which it has now replaced as a coolant. With it, not only is cold weather operation simpli-

fied, but also higher and therefore more efficient engine temperatures are possible and, consequently, smaller radiators can be used.

19. The cylinders of liquid-cooled engines are invariably arranged in line along the crankshaft, in one or more banks, this disposition facilitating the flow of coolant and presenting a small frontal area. Furthermore, the neat streamlined housing possible with this arrangement enables the drag to be reduced to a low value, even taking into account the drag of the radiator, which in the ducted type is very small.

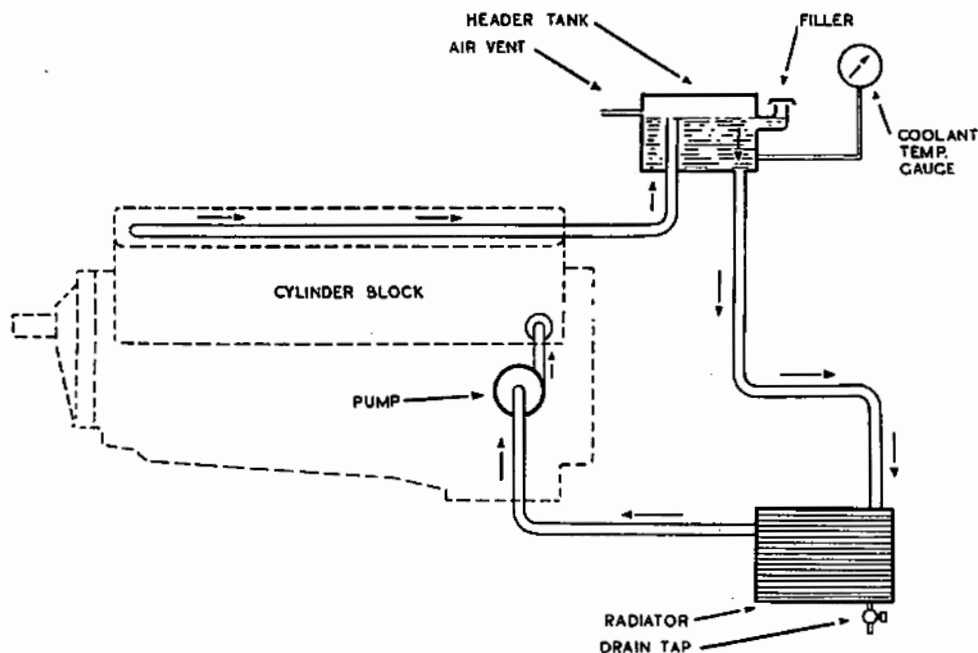

Fig. 6. Liquid Cooling System.

This file was downloaded
from the RTFM Library.

Link: www.scottbouch.com/rtfm

Please see site for usage terms,
and more aircraft documents.

