

RESTRICTED

PART 2: SECTION 2

CHAPTER 4

MACHMETERS

Purpose

1. The purpose of the machmeter is to provide the pilot with a continuous indication of the ratio of the true airspeed of an aircraft to the true speed of sound at the same height.

2. Knowledge of this ratio, or mach number as it is called, is of paramount importance to the pilot, since various factors relating to aircraft performance are expressed in terms of mach numbers. There is therefore a requirement for an instrument to provide the pilot with an immediate indication of the aircraft T.A.S./local sonic speed relationship.

Implementation

3. The machmeter indicates aircraft speed as a mach number. It is virtually a mechanical brain which calculates and presents a continuous indication of the answer to the equation :

Mach Number = T.A.S./Local Sonic Speed.

4. As T.A.S. and local sonic speed are functions of pitot pressure and density, and static pressure and density, respectively, and since density is a factor of both, the equation can also be expressed thus :

$$\text{Mach Number} = \frac{P - S}{S}$$

Where P = Pitot Pressure
and S = Static Pressure.

5. To implement its purpose the machmeter has two main elements, one responsive to airspeed and the other to altitude, similar to the mechanisms of the A.S.I. and pressure altimeter respectively. These elements are mechanically interlinked to a pointer so that the pointer indicates, as a decimal value, the relationship between aircraft T.A.S. at any height and sonic speed at the same altitude. The operating principle is illustrated in Fig. 1, where it can be seen that the indicating pointer is actuated by a main arm which is itself governed by the movements of both the altitude and airspeed capsules.

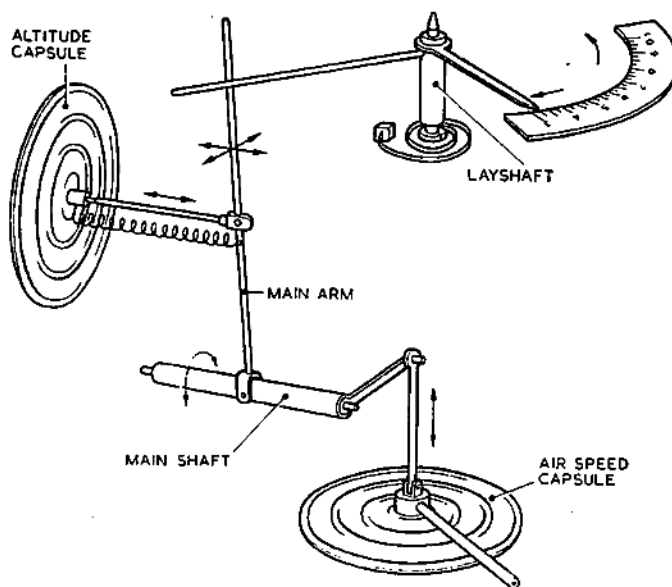

Fig. 1. Principle of the Machmeter.

RESTRICTED

RESTRICTED

A.P. 129, VOL. 1, PART 2, SECT. 2, CHAP. 4

Description

6. The graduated scale on the Mk. 1A and Mk. 1A* covers the range Mach 0.5 to Mach 1 and, reading clockwise, starts with Mach 0.5 at "seven o'clock" (Fig. 2) and ends with Mach 1.0 at "five o'clock". The zero position of the pointer is at "six o'clock".



Fig. 2. Mk. 1A* Machmeter.

7. The dial of the Mk. 1B (Fig. 3) has a different presentation since the critical portion of the Mk. 1A* scale has proved difficult to read in most aircraft owing to the cockpit coaming

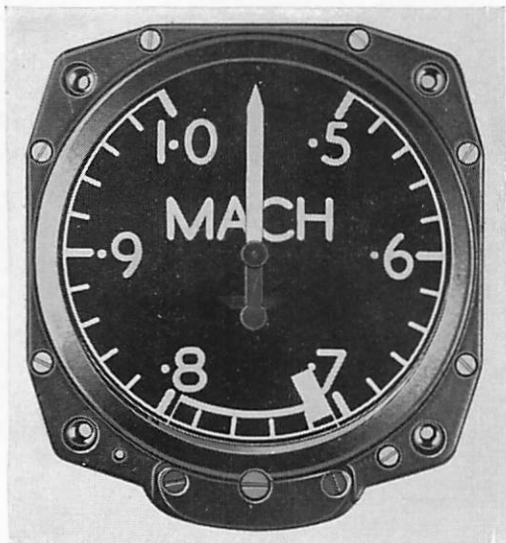

Fig. 3. Mk. 1B Machmeter.

obstructing the pilot's line of sight. The Mk. 1B presentation, reading clockwise, starts with Mach 0.5 at "one o'clock" and has the Mach 1.0 graduation at "eleven o'clock". The zero position of the Mk. 1B pointer is at "twelve o'clock".

8. The graduated scale of the Mk. 2 covers the same range as the Mk. 1B and the presentation is similar.

9. The Mk. 3A model (Fig. 4) operates over the range Mach 0.7 to Mach 1.3 and, reading clockwise, it starts with Mach 0.7 at "one o'clock" and ends with Mach 1.3 at "eleven o'clock".

10. Constructional details are available in A.P. 1275B, Instrument Manual (Navigation Instruments).

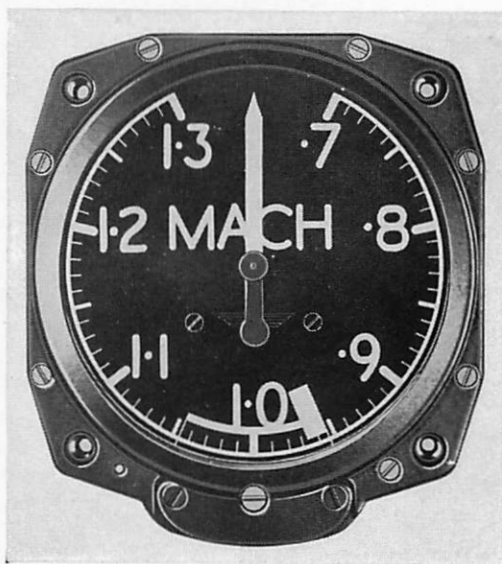

Fig. 4. Mk. 3A Machmeter.

Errors

11. **Pressure Error.** Since it operates from the same pitot and static sources as the A.S.I., the machmeter is subject to pressure error, *i.e.* the error due to the false static pressure in the immediate vicinity of the aircraft during flight. The relationship between true and indicated mach numbers is not the same as that between true and indicated airspeeds, however, since the I.A.S./T.A.S. relationship is largely influenced by the effect of altitude, a factor for which the machmeter corrects automatically. Moreover, pressure error over the operating range of this instrument is small ;

RESTRICTED

therefore the difference between indicated and true mach numbers is small. (Note: Part 1, Section 1, Chapter 2, "Speed Measurement", deals with this matter in greater detail.)

12. **Instrument Error.** The machmeter is subject to instrument error, the extent of which varies from one instrument to another, and may vary from time to time in individual instruments according to age and general condition. Maximum instrument error tolerances are specified for the different marks of machmeter. These are :—

(a) *Mk. 1A, Mk. 1A*, and Mk. 1B.* Plus or minus Mach 0.01 over the range Mach 0.6 to 0.85, and plus or minus Mach 0.02 over the rest of the range.

(b) *Mk. 2.* Plus or minus Mach 0.01 over the range Mach 0.5 to 0.7, and plus or minus Mach 0.005 over the remainder of the range.

(c) *Mk. 3A.* Plus or minus Mach 0.01 over the whole operating range of the instrument.

Limitations

13. All the Mk. 1 series instruments and the Mk. 2 are suitable for use in the range Mach 0.5 to 1.0 in the height range 0 to 50,000 feet.

14. The Mk. 3A is suitable for use throughout the range Mach 0.7 to 1.3 from sea level to 60,000 feet.

Pilot's Serviceability Checks

15. **On the Ground.** Beyond noting that the pointer has not struck at a position other than "six o'clock" or "twelve o'clock", according to the mark of instrument, the pilot can do nothing to check the serviceability of the machmeter before flight.

16. **In the Air.** At low level, the machmeter may be checked by comparison with the airspeed indicator reading. An indicated reading of 0.5 corresponds approximately to an R.A.S. of 330 knots.

This file was downloaded
from the RTFM Library.

Link: www.scottbouch.com/rtfm

Please see site for usage terms,
and more aircraft documents.

