

MINISTRY OF SUPPLY
CENTRAL
LIBRARY

Chapter I

REPAIR OF DUNLOP WHEELS

(This chapter supersedes that issued with A.L. No. 16)

1. This chapter contains information to guide personnel in the repair of certain wheels that have been rendered unserviceable through wear or damage.

2. Each wheel repair is given the code letters "RP" followed by the repair number. The repairable wheels are tabulated in the List of Wheels and Relevant Repair Schemes and the "RP" and relevant Volume 1 appendix numbers are given in the adjoining columns. Details of special tools and repair parts which are fundamentally similar are given in Tables that follow the List of Wheels and Relevant Repair Schemes.

3. The repairs generally are confined to wheels in which the housings for the bearings have become enlarged with the result that the outer tracks of the bearings creep. When this condition arises a repair scheme, if practicable,

is compiled to give instructions for enlarging the bearing housings and fitting steel liners. After being fitted the liners are machined to the dimensions of the original housings to accommodate new bearings. It should be noted that where no tolerances are given for certain dimensions shown on the repair drawings, the following limits will apply: ± 0.005 in. for dimensions shown in decimal figures, ± 0.015 in. for dimensions shown in fractional figures.

4. Appendix 1 to the chapter contains recommendations on the setting-up and machining of wheels in lathes. Appendix 2 deals with brake drum clearances, permissible distortion limits and grinding; it also enumerates the conditions under which the brake drums listed in Tables 2 and 3 may be considered as repairable.

LIST OF WHEELS AND RELEVANT REPAIR SCHEMES

Wheel Part No.	Issue No.	Vol.1 Ref. Sect. 1, Chap. 1 Appendix	Repair scheme RP No.	Wheel Part No.	Issue No.	Vol.1 Ref. Sect. 1, Chap. 1 Appendix	Repair scheme RP No.
AH.8218		1	1	AH.9420		37	
AH.8375		2	28,85	AH.9422		38	41
AH.8391		3	85	AH.9006		39	44
AH.8208		4	7,85	AH.9073		40	45
AH.8438		5		AH.9504	1,3, 4 &Sub.	41	2,3,9
AH.8519		6	28,45	AH.8379		42	38
AH.8406		7	85	AH.9596		43	45
AH.8310		8		AH.9548		44	60
AH.8405		9	57	AH.50787		44	60
AH.8435	1-6,7 & Sub.	10	2,3,9	AH.9471		45	
AH.8137	1-14,15 & Sub.	11	2,3,9	AH.9379		46	
AH.8736	1-6,7 &Sub.	12	2,3,9	AH.9406		47	
AH.8792		13		AH.9808		48	
AH.8563		14		AH.8176		49	85
AH.8725		15	13,45	AH.9139		50	26,45
AH.8891		16		AH.9505		51	45
AH.8385		17		AH.9838		52	5
AH.9092		18		AH.9839		53	5
AH.8980		19		AH.50207		54	42,156, 134
AH.8064		20		AH.9669		55	40
AH.10245		21		AH.9729		56	100
AH.10025		22		AH.9415		57	12,45
AH.8053		23		AH.9485		58	14,423
AH.10019		24		AH.9372	3 & Sub.	59	2,3,9
AH.10158		25		AH.9811		60	100,195
AH.2238		26		AH.8444		61	
AH.2016		27		AH.9489		62	44
AH.10020		28	55	AH.9638		63	171
AH.851		29	27	AH.9614		64	195
AH.8943		30	70	AH.9779		65	100,106
AH.8049		31		AH.50159		66	195
AH.9389		32		AH.50273		67	45
AH.9480		33	11	AH.9898		68	168
AH.8152		34	37	AH.50285		69	195
AH.9191		35		AH.50032		70	168
AH.9343		36	14,100,423				

(continued overleaf)

Note . . .

Details of tools and repair parts which are fundamentally similar are given in Tables following this List.

LIST OF WHEELS AND RELEVANT REPAIR SCHEMES (Cont'd)

Wheel Part No.	Issue No.	Vol. I Ref. Sect. 1, Chap. 1 Appendix	Repair scheme RP No.	Wheel Part No.	Issue No.	Vol. I Ref. Sect. 1, Chap. 1 Appendix	Repair scheme RP No.
AH.50021		71	168	AH.50663		89	
AH.9843		72	195	AH.50637		90	168
AH.50439		73	195, 423	AH.50906		91	
AH.50434		74		AH.50521		92	168
AH.50122		75	168, 195, 182, 167	AH.50949		93	168
AH.50116		76	168, 195, 480	AH.50556		94	168
AH.9361		77	195	AH.50417		95	
AH.50268		78	168, 195	AH.50907		96	168
AH.50528		79	168	AH.50207		54	204
AH.50611		80	168, 195, 184	AH.50701		88	204
AH.50660		81	195	AH.51154			204
AH.50579		82	168	AHO.5048		34, 35	209
AH.50702		83		AH.50787			345
AH.50578		84		AH.50207, 50701			418
AH.50435		85		AH.9729			464
AH.9982		86	168, 188, 187	AH.51337		107	423
AH.50787		87	60	AH.50945		112	526
AH.50701		88		AH.51631		113	480
				AH.9729		56	541
				AH.51328		108	480
				AH.51748		120	595, 480
				AH.52157		120	480

RESTRICTED

TABLE I
 Details of liners for wheel-bearing housings
 (dimensions in inches)

Part No.	Material Spec.	A (dia.)	B (dia.)	C	D (dia.)	E	R.1 (rad.)	R.2 (rad.)	Treatment
RP.1/5A	S2, S11 or equiv.	$\frac{3.654}{3.655}$	$\frac{3.450}{3.452}$	$\frac{0.810}{0.820}$	$\frac{3.120}{3.130}$	$\frac{0.120}{0.130}$	$\frac{0.055}{0.065}$	$\frac{0.095}{0.105}$	Cadmium plate
RP.1/5B	S2, S11 or equiv.	$\frac{3.259}{3.260}$	$\frac{3.050}{3.052}$	$\frac{0.850}{0.860}$	$\frac{2.620}{2.630}$	$\frac{0.120}{0.130}$	$\frac{0.055}{0.065}$	$\frac{0.095}{0.105}$	Cadmium plate
RP.2/5	S2, S11 or equiv.	$\frac{5.909}{5.911}$	$\frac{5.650}{5.652}$	$\frac{1.520}{1.530}$	$\frac{5.370}{5.380}$	$\frac{0.182}{0.192}$	$\frac{0.055}{0.065}$	$\frac{0.120}{0.130}$	Cadmium plate
RP.7/6A	S2, S11 or equiv.	$\frac{3.864}{3.865}$	$\frac{3.656}{3.658}$	$\frac{0.775}{0.785}$	$\frac{3.432}{3.442}$	$\frac{0.151}{0.161}$	$\frac{0.055}{0.065}$	$\frac{0.095}{0.105}$	Cadmium plate
RP.7/6B	S2, S11 or equiv.	$\frac{3.864}{3.865}$	$\frac{3.656}{3.658}$	$\frac{0.995}{1.005}$	$\frac{3.307}{3.317}$	$\frac{0.151}{0.161}$	$\frac{0.055}{0.065}$	$\frac{0.095}{0.105}$	Cadmium plate
RP.11/7A	S2, S11 or equiv.	$\frac{4.240}{4.241}$	$\frac{4.057}{4.067}$	$\frac{0.952}{0.962}$	$\frac{3.745}{3.755}$	$\frac{0.120}{0.130}$	$\frac{0.045}{0.055}$	$\frac{0.095}{0.105}$	Cadmium plate
RP.11/7B	S2, S11 or equiv.	$\frac{4.905}{4.906}$	$\frac{4.700}{4.710}$	$\frac{1.097}{1.107}$	$\frac{4.370}{4.380}$	$\frac{0.120}{0.130}$	$\frac{0.045}{0.055}$	$\frac{0.095}{0.105}$	Cadmium plate
RP.12/6B	S94, S95 or S96	$\frac{2.946}{2.945}$	$\frac{2.752}{2.742}$	$\frac{1.235}{1.225}$	$\frac{2.442}{2.432}$	$\frac{0.130}{0.120}$	$\frac{0.065}{0.035}$	$\frac{0.105}{0.095}$	Cadmium plate
RP.12/6A	S94, S95 or S96	$\frac{4.050}{4.049}$	$\frac{3.855}{3.845}$	$\frac{0.852}{0.847}$	$\frac{3.505}{3.495}$	$\frac{0.130}{0.120}$	$\frac{0.065}{0.035}$	$\frac{0.105}{0.095}$	Cadmium plate
RP.13/6	S2, S11 or equiv.	$\frac{3.652}{3.653}$	$\frac{3.448}{3.450}$	$\frac{1.056}{1.066}$	$\frac{3.000}{3.005}$	$\frac{0.120}{0.130}$	$\frac{0.055}{0.065}$	$\frac{0.095}{0.105}$	Cadmium plate
RP.14/6	S2, S11 or equiv.	$\frac{5.936}{5.937}$	$\frac{5.656}{5.658}$	$\frac{1.635}{1.645}$	$\frac{5.370}{5.380}$	$\frac{0.120}{0.130}$	$\frac{0.055}{0.065}$	$\frac{0.095}{0.105}$	Cadmium plate
RP.26/7A	S2, S11 or equiv.	$\frac{3.655}{3.654}$	$\frac{3.455}{3.445}$	$\frac{0.965}{0.955}$	$\frac{3.005}{3.000}$	$\frac{0.161}{0.151}$	$\frac{0.075}{0.045}$	$\frac{0.115}{0.085}$	Cadmium plate
RP.26/7B	S2, S11 or equiv.	$\frac{3.260}{3.259}$	$\frac{3.065}{3.055}$	$\frac{0.917}{0.915}$	$\frac{2.630}{2.625}$	$\frac{0.161}{0.151}$	$\frac{0.075}{0.045}$	$\frac{0.115}{0.085}$	Cadmium plate
RP.27/6	S2, S11 or equiv.	$\frac{2.622}{2.623}$	$\frac{2.495}{2.505}$	$\frac{0.644}{0.646}$	$\frac{2.146}{2.166}$	$\frac{0.100}{0.110}$	$\frac{0.045}{0.075}$	$\frac{0.085}{0.115}$	Cadmium plate

Cont. overleaf

TABLE I--continued

Part No.	Material Spec.	A (dia.)	B (dia.)	C	D (dia.)	E	R.1 (rad.)	R.2 (rad.)	Treatment
RP.28/6A	S2, S11 or equiv.	$\frac{3.724}{3.725}$	$\frac{3.500}{3.510}$	$\frac{0.807}{0.817}$	$\frac{3.120}{3.130}$	$\frac{0.120}{0.130}$	$\frac{0.030}{0.060}$	$\frac{0.085}{0.115}$	Cadmium plate
RP.28/6B	S2, S11 or equiv.	$\frac{3.004}{3.005}$	$\frac{2.780}{2.790}$	$\frac{1.179}{1.189}$	$\frac{2.370}{2.380}$	$\frac{0.120}{0.130}$	$\frac{0.030}{0.060}$	$\frac{0.085}{0.115}$	Cadmium plate
RP.37/6	S.94, S.95 or S.96	$\frac{2.216}{2.215}$	$\frac{2.098}{2.088}$	$\frac{0.415}{0.410}$	$\frac{1.880}{1.870}$	$\frac{0.105}{0.095}$	$\frac{0.065}{0.035}$	$\frac{0.105}{0.095}$	Cadmium plate
RP.38/6A	S.94, S.95 or S.96	$\frac{3.871}{3.870}$	$\frac{3.710}{3.700}$	$\frac{0.687}{0.682}$	$\frac{3.442}{3.432}$	$\frac{0.130}{0.120}$	$\frac{0.075}{0.045}$	$\frac{0.105}{0.095}$	Cadmium plate
RP.38/6B	S.94, S.95 or S.96	$\frac{3.871}{3.870}$	$\frac{3.710}{3.700}$	$\frac{0.903}{0.901}$	$\frac{3.317}{3.307}$	$\frac{0.130}{0.120}$	$\frac{0.075}{0.045}$	$\frac{0.105}{0.095}$	Cadmium plate
RP.40/6A	S.94, S.95 or S.96	$\frac{4.272}{4.271}$	$\frac{4.072}{4.062}$	$\frac{1.040}{1.030}$	$\frac{3.817}{3.807}$	$\frac{0.166}{0.156}$	$\frac{0.075}{0.045}$	$\frac{0.115}{0.085}$	Cadmium plate
RP.40/6B	S.94, S.95 or S.96	$\frac{3.607}{3.606}$	$\frac{3.437}{3.427}$	$\frac{1.010}{1.000}$	$\frac{3.192}{3.182}$	$\frac{0.166}{0.156}$	$\frac{0.075}{0.045}$	$\frac{0.115}{0.085}$	Cadmium plate
RP.55/3	S.94, S.95 or S.96	$\frac{3.410}{3.409}$	$\frac{3.255}{3.245}$	$\frac{0.827}{0.797}$	$\frac{2.755}{2.745}$	$\frac{0.140}{0.110}$	$\frac{0.115}{0.085}$	$\frac{0.075}{0.045}$	Cadmium plate
RP.57/2	S.94, S.95 or S.96	$\frac{9.961}{9.960}$	$\frac{9.505}{9.495}$	$\frac{2.015}{1.985}$	$\frac{8.505}{8.495}$	$\frac{0.327}{0.297}$	$\frac{0.075}{0.045}$	$\frac{0.265}{0.235}$	Cadmium plate
RP.33/3	S.11	$\frac{6.537}{6.536}$ (6.538 max. after plating)	$\frac{6.155}{6.145}$	$\frac{1.805}{1.795}$	$\frac{5.692}{5.682}$	$\frac{0.400}{0.390}$	$\frac{0.090}{0.060}$	$\frac{0.187}{0.156}$	Cadmium plate
RP.171/1A	Dural L.64	$\frac{4.165}{4.164}$	$\frac{3.905}{3.895}$	$\frac{0.840}{0.838}$	$\frac{3.505}{3.495}$	$\frac{0.135}{0.125}$	$\frac{0.065}{0.055}$	$\frac{0.065}{0.055}$	

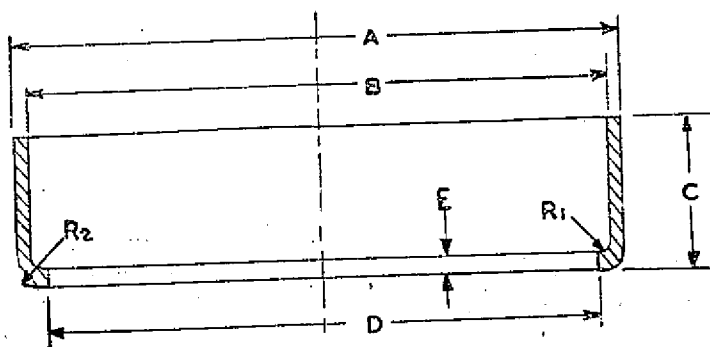

CADMIUM PLATE TO SPECIFICATION D.T.D.904

RESTRICTED

TABLE 2
Press tool details
 (dimensions in inches)

Part No.	Material Spec.	A (dia.)	B (dia.)	C	D	E	F	G (dia.)	H (deg.)	R.1 (rad.)	R.2 (rad.)	Heat treatment	Anti-corrosive treatment
RT.1	S.14 or EN.32	3.245 3.255	3.038 3.040	$\frac{7}{16}$	$\frac{13}{16}$	$1\frac{3}{4}$	$\frac{1}{8}$	$3\frac{7}{8}$	30	$\frac{1}{32}$ ± 0.010	$\frac{1}{16}$	Case harden	Cadmium plate
RT.2	S.14 or EN.32	3.635 3.645	3.438 3.440	$\frac{7}{16}$	$\frac{13}{16}$	$1\frac{3}{4}$	$\frac{1}{8}$	$4\frac{1}{8}$	30	$\frac{1}{32}$ ± 0.010	$\frac{1}{16}$	Case harden	Cadmium plate
RT.3	S.14 or EN.32	5.875 5.885	5.638 5.640	$\frac{5}{8}$	$1\frac{1}{2}$	$2\frac{1}{8}$	$\frac{1}{8}$	$6\frac{7}{16}$	30	$\frac{1}{32}$ ± 0.010	$\frac{1}{16}$	Case harden	Cadmium plate
RT.7	S.14 or EN.32	4.885 4.895	4.693 4.698	$\frac{7}{16}$	$\frac{13}{16}$	$1\frac{3}{4}$	$\frac{1}{8}$	$5\frac{1}{2}$	30	$\frac{1}{32}$ ± 0.010	$\frac{1}{16}$	Case harden	Cadmium plate
RT.8	S.14 or EN.32	4.220 4.230	4.050 4.055	$\frac{7}{16}$	$\frac{13}{16}$	$1\frac{3}{4}$	$\frac{1}{8}$	$4\frac{1}{2}$	30	$\frac{1}{32}$ ± 0.010	$\frac{1}{16}$	Case harden	Cadmium plate
RT.9	S.14 or EN.32	5.916 5.926	5.649 5.654	$\frac{7}{16}$	$\frac{13}{16}$	$1\frac{3}{4}$	$\frac{1}{8}$	$6\frac{1}{2}$	30	$\frac{1}{32}$ ± 0.010	$\frac{1}{16}$	Case harden	Cadmium plate
RT.10	S.14 or EN.32	2.925 2.935	2.735 2.740	$\frac{7}{16}$	$\frac{13}{16}$	$1\frac{3}{4}$	$\frac{1}{8}$	$3\frac{1}{2}$	30	$\frac{1}{32}$ ± 0.010	$\frac{1}{16}$	Case harden	Cadmium plate
RT.11	S.14 or EN.32	4.030 4.040	3.838 3.843	$\frac{7}{16}$	$\frac{13}{16}$	$1\frac{3}{4}$	$\frac{1}{8}$	$4\frac{1}{2}$	30	$\frac{1}{32}$ ± 0.010	$\frac{1}{16}$	Case harden	Cadmium plate
RT.14	S.14 or EN.32	3.844 3.854	3.649 3.654	$\frac{7}{16}$	$\frac{7}{8}$	$1\frac{3}{4}$	$\frac{1}{8}$	$4\frac{3}{16}$	30	$\frac{1}{32}$ ± 0.010	$\frac{1}{16}$	Case harden	Cadmium plate
RT.19	S.14 or EN.32	2.602 2.612	2.488 2.493	$\frac{7}{16}$	$\frac{3}{4}$	$1\frac{1}{2}$	$\frac{1}{8}$	$2\frac{7}{8}$	30	$\frac{1}{32}$ ± 0.010	$\frac{1}{16}$	Case harden	Cadmium plate
RT.20	S.14 or EN.32	3.705 3.715	3.493 3.498	$\frac{7}{16}$	$\frac{3}{4}$	$1\frac{1}{2}$	$\frac{1}{8}$	$4\frac{1}{8}$	30	$\frac{1}{32}$ ± 0.010	$\frac{1}{16}$	Case harden	Cadmium plate
RT.21	S.14 or EN.32	2.985 2.995	2.773 2.778	$\frac{5}{8}$	$\frac{1}{2}$	$1\frac{7}{16}$	$\frac{1}{8}$	$3\frac{1}{8}$	30	$\frac{1}{32}$ ± 0.010	$\frac{1}{16}$	Case harden	Cadmium plate

Cont. overleaf

NOTE.—Dimension B to apply after plating and face shown thus * to be perfectly square to periphery of B.

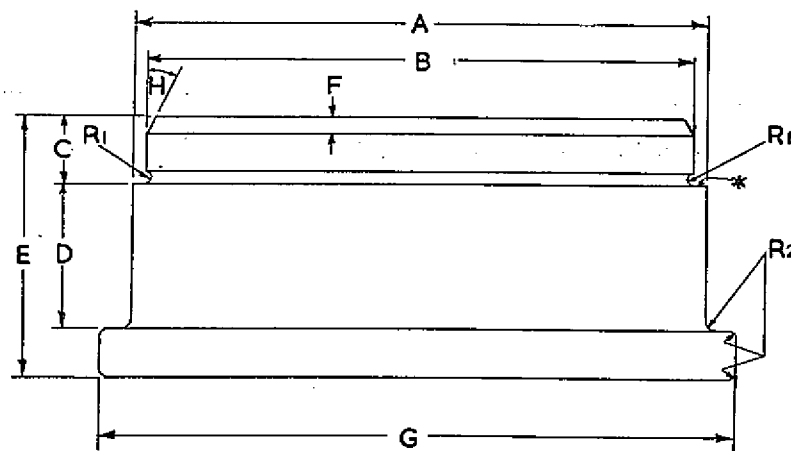

Note . . .
 General tolerance for fractional dimensions, $\pm \frac{1}{64}$ in. unless otherwise stated. Cadmium plate to Specification D.T.D.904.

RESTRICTED

(A.L.19, Mar. 54)

TABLE 2—continued

Part No.	Material Spec.	A (dia.)	B (dia.)	C	D	E	F	G (dia.)	H (deg.)	R.1 (rad.)	R.2 (rad.)	Heat treatment	Anti-corrosive treatment
RT.23	S.14 or EN.32	3-250 3-240	3-053 3-048	$\frac{7}{16}$	$\frac{11}{16}$	$1\frac{1}{2}$	$\frac{1}{8}$	$3\frac{11}{16}$	30	$\frac{1}{32}$ ± 0.010	$\frac{1}{16}$	Case harden	Cadmium plate
RT.27	S.14 or EN.32	2-205 2-195	2-086 2-081	$\frac{1}{2}$	$\frac{3}{4}$	$1\frac{3}{8}$	$\frac{3}{32}$	$2\frac{11}{32}$	30	$\frac{1}{32}$ ± 0.010	$\frac{1}{16}$	Case harden	Cadmium plate
RT.28	S.14 or EN.32	3-860 3-850	3-698 3-693	$\frac{7}{16}$	$\frac{3}{4}$	$1\frac{9}{16}$	$\frac{1}{8}$	$4\frac{3}{32}$	30	$\frac{1}{32}$ ± 0.010	$\frac{1}{16}$	Case harden	Cadmium plate
AO. 100772	S.14 or EN.32	4-260 4-250	4-060 4-055	$\frac{5}{8}$	$\frac{3}{4}$	$1\frac{3}{4}$	$\frac{1}{8}$	$4\frac{5}{8}$	30	$\frac{1}{32}$ ± 0.010	$\frac{1}{16}$	Case harden	Cadmium plate
AO. 100773	S.14 or EN.32	3-596 3-586	3-425 3-420	$\frac{5}{8}$	$\frac{3}{4}$	$1\frac{3}{4}$	$\frac{1}{8}$	4	30	$\frac{1}{32}$ ± 0.010	$\frac{1}{16}$	Case harden	Cadmium plate

NOTE.—Dimension B to apply after plating and face shown thus * to be perfectly square to periphery of B.

RESTRICTED

TABLE 3
Press tool details
 (Dimensions in inches)

Part No.	Material Spec.	A (dia.)	B (dia.)	C	D	E	F	G (dia.)	H (deg.)	R.1 (rad.)	R.2 (rad.)	J (chamfer)	K (dia.)	Heat treatment	Anti-corrosive treatment
AO.100785	EN32B	2.935	2.740	1/8	1/8	1 1/4	1/8	3 1/2	30	3/32	1/8	1/8 X 45 deg.	0.7503 0.7497	Case harden	Cadmium plate
		2.925	2.735	1/8	1/8	1 1/4	1/8	3 1/2	30	3/32	1/8	1/8 X 45 deg.	0.7503 0.7497	Case harden	Cadmium plate
AO.100786	EN32B	4.039	3.840	1/8	1/8	1 1/4	1/8	4 1/2	30	3/32	1/8	1/8 X 45 deg.	0.7503 0.7497	Case harden	Cadmium plate
		4.029	3.835	1/8	1/8	1 1/4	1/8	4 1/2	30	3/32	1/8	1/8 X 45 deg.	0.7503 0.7497	Case harden	Cadmium plate

Note . . .

Dimension B to apply after plating and face shown thus * to be square to periphery of B.

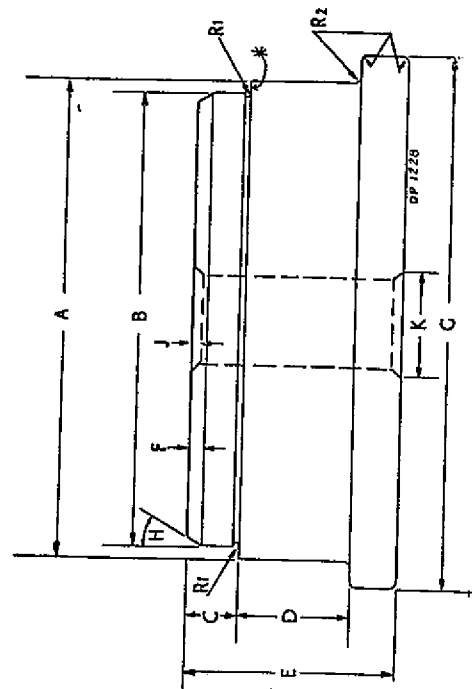

RESTRICTED

MINISTRY OF DEFENCE
CENTRAL
LIBRARY

TABLE 4
Shim details
(Dimensions in inches)

Part No.	Material Spec.	A (width)	B (length)	Thickness	C (int. dia.)	Treatment
RP.60/2	S3	$\frac{0.598}{0.588}$	$\frac{12.920}{12.910}$	30 S.W.G. (1st stage repair) 28 S.W.G. (2nd stage repair)	$\frac{4.122}{4.119}$	Cadmium plate to Spec. D.T.D.904
RP.60/5	S3	$\frac{0.630}{0.620}$	$\frac{10.960}{10.950}$	30 S.W.G. (1st stage repair) 28 S.W.G. (2nd stage repair)	$\frac{3.497}{3.494}$	Cadmium plate to Spec. D.T.D.904
RP.171/1B	S3	$\frac{0.550}{0.540}$	$\frac{8.918}{8.903}$	30 S.W.G.	—	Cadmium plate to Spec. D.T.D.904

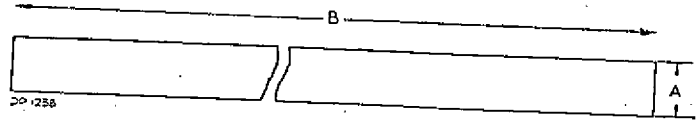

STRIP TO BE FORMED INTO A CIRCLE OF INTERNAL DIA. C IN.

F.S./6

B (AL75)

RESTRICTED

Appendix I . . . RECOMMENDATIONS ON THE SETTING-UP AND MACHINING OF WHEELS IN LATHES

Setting-up

1. Where wheels are being repaired in considerable numbers, some devices are required which will facilitate the speedy setting-up of the wheels in lathes.

2. A substantial time economy can be effected by the fitting of special soft iron jaws to a three-jaw concentric chuck. Soft iron jaws can be obtained to suit most makes of chuck. They take the form of an oblong block or pad of iron which is designed to bolt on to the chuck in place of the normal stepped jaw. Steps should

be machined in the pads to accommodate the various diameters of the wheels most frequently encountered. The special chuck illustrated in fig. 1 is an example of this setting-up device.

3. If the special jaws are disturbed for any reason (for example, if they are removed from the chuck whilst an ordinary job is being machined) it is advisable to skim out the steps again to ensure concentricity of the work. It is extremely difficult to replace the jaws on the chuck in exactly their original positions.

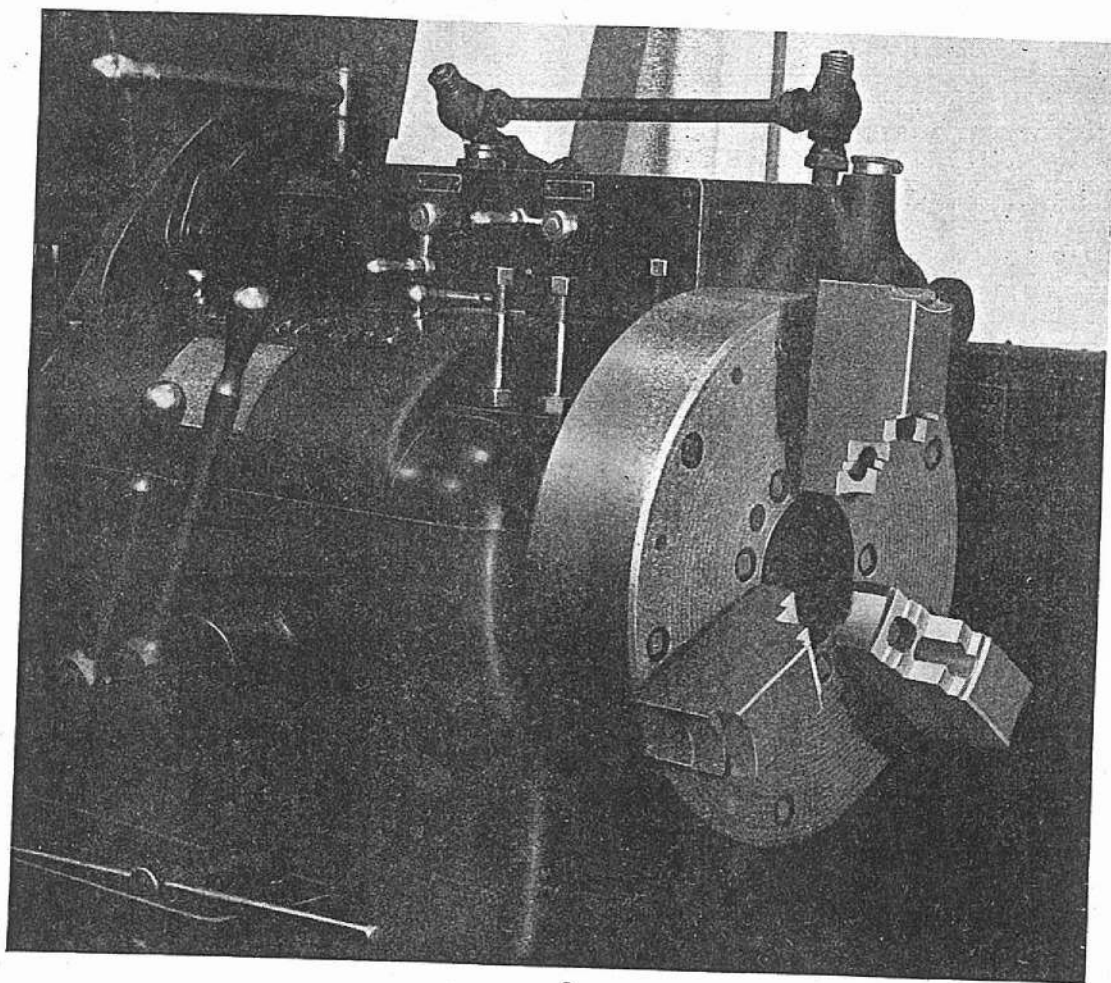

Fig. 1.—Typical soft iron jaws

~~RESTRICTED~~

4. To facilitate the planary alignment of a wheel in the chuck, it is recommended that a dial test indicator be attached to a suitable cranked piece, and held in the tool post of the lathe. The operator should "clock" on to the machined face of the wheel bearing housing to an accuracy of 0.001 in. (that is to say, as the wheel is turned in the lathe with the contact point of the dial test indicator touching the face of the bearing housing, the needle of the indicator must not oscillate to a reading of more than 0.001 in. at each revolution of the wheel).

Machining

5. Air Diagram No. 216—"Types of lathe tools" gives particulars of the cutting speeds and tool proportions for various metals.

6. It is emphasised here that when elektron magnesium alloy is being machined, deep cuts must be taken wherever possible. The tool must not be allowed to rub on the work, otherwise an ignition of the swarf may occur. The swarf should be collected at frequent intervals, to be disposed of in properly lidded steel bins.

Examine

1. The demar drums satisfactorily period and the period scheduled maximum

2. V new disto 13. 2 unit limit

3. reve rigs Tab the limit serv hav whi

R E S T R I C T E D

Appendix 2

BRAKE DRUM CLEARANCES, PERMISSIBLE DISTORTION LIMITS, AND GRINDING

(This Appendix supersedes that issued with A.L. No. 11)

Examination

1. The arduous conditions of aircraft braking demands that periodic examinations of brake drums and linings be made to ensure their satisfactory functioning. The servicing period may vary with the class of aircraft and the conditions of service, and where a period has been laid down in a servicing schedule this should always be regarded as a maximum.
2. When a brake unit is to be fitted with new linings the drum must be checked for distortion and classified as detailed in para. 13. New linings must not be fitted to a brake unit when a drum is distorted beyond the limits.
3. Permissible limits of distortion, as revealed by an inspection check on the test rigs illustrated in fig. 1 and 2, are given in Table 1 for drums of both the integral and the isolated steel types. All drums within the limits stated will be found to give satisfactory service. Improvements in brake drum design have led to the bi-metal construction in which distortion due to heat is reduced.

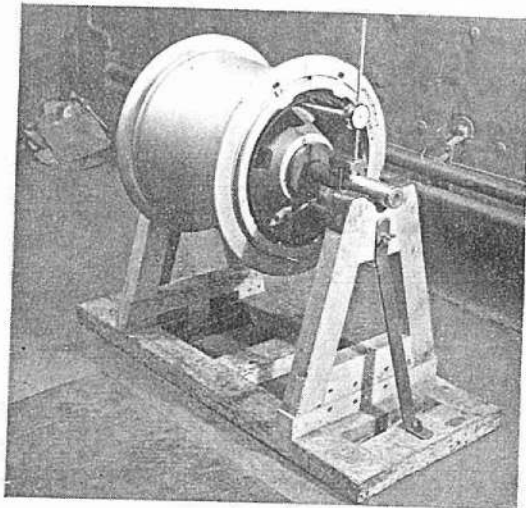

Fig. 1. Wheel rotated on dummy shaft, measuring equipment stationary

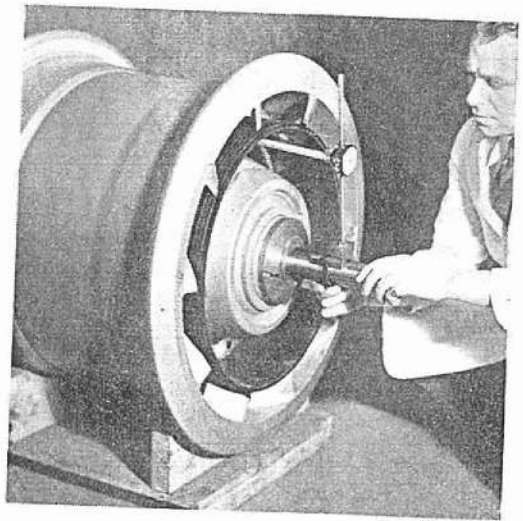

Fig. 2. Measuring equipment rotated on dummy shaft; wheel stationary

4. Use of the test rigs will give an accurate and readily apparent indication of the brake drum distortion. Checking with pin gauges, revealing only local conditions, is not recommended.
5. Wear in the wheel bearings will not be reflected in the indicator readings if the check is made with the wheel in a horizontal position.
6. At the servicing period the drums should be examined for scoring or cracks. Renewal of worn shoes must always comprise a complete set of segments and separators. The minimum permissible worn thickness is shown in Table 1.

Brake drum distortion

7. Brake drum distortion normally takes the form of a movement of the drum wall towards the centre of the wheel. This movement may be local or general and consequently has the effect of wholly or locally reducing the nominal brake drum radius. If

types of lathe cutting speeds metals.

when elektron 1, deep cuts The tool the work, may occur. frequent early litted

through wear, the brake linings are reduced in thickness the brake clearance may be temporarily satisfactory but could be insufficient over a new set of linings. To restore a satisfactory radius and clearance, a brake drum which has not come under the rejected category as detailed in para. 13 may be removed from the wheel and be ground to remove a strictly limited amount of metal from the drum wall.

Checking for distortion

8. Because the brake drum rotates with the wheel it is essential that the bearing centre line be used as a reference and that the distortion be checked radially from that line.

9. To effect the check it is necessary to assemble the bearings into the wheel and to pass an accurately fitted mandrel through bushes fitted into the bearing inner races or, in the case of wheels mounting parallel axles, through the races themselves. Ball and parallel roller bearings will, within their own limits of permissible wear (which for the purpose of this check are negligible), locate the mandrel centrally in the wheel. Where taper roller bearings are used it is essential that the inner races and rollers are entered into the outer races sufficiently to centralise the mandrel and permit rotation of the bearings. When wheels are checked with bearings of this type both the mandrel and the bearings must be positively restrained from axial movement; a pair of clamp rings on the mandrel are recommended as suitable for this purpose.

10. A surface gauge must then be clamped to the mandrel by a single stirrup clamp and a universal dial test indicator (*Stores Ref. 1B/2906*) secured at a suitable height on the pillar of the surface gauge (*fig. 2*).

11. With the indicator rigged as described in the preceding paragraph it must be further positioned on the surface gauge pillar so that when approximately one half of the plunger movement is absorbed the button is at the distance $\frac{1}{2}A$ (*see Table 2 or 3*) from the mandrel centre line. At this position of the button, the dial of the indicator must be adjusted to read zero.

12. With the indicator set as described in the preceding paragraph, the clamp should be slackened and the surface gauge advanced on the mandrel into the drum until the button rides on the drum wall $\frac{1}{2}$ in. to $\frac{3}{4}$ in. from the

mounting flange. When the stirrup clamp has been secured, the mandrel and the gauge must be given one or two complete revolutions during which the extremes of dial readings must be observed. Two further circumferential checks must be made one at the centre of the drum wall and one at $\frac{1}{2}$ in. to $\frac{3}{4}$ in. from the lip of the drum.

13. The information given in Tables 2 and 3 gives the essential limits for determining whether a brake drum is still serviceable, repairable, or unfit for further service, and may be interpreted as follows:—

(1) A brake drum is fit for further service with new linings when the minimum nominal drum diameter is not less than the reading given in column A.

(2) A brake drum may be repaired:—

(a) If the maximum diameter is not in excess of the reading given in column B.

(b) If the minimum diameter is not less than the reading given in column C.

(3) The maximum permissible dial gauge variation between the maximum and minimum diameters of the brake drum must not exceed the reading in column D. This variation is 0.010 in. less than the difference between columns B and C to allow a 0.005 in. clean up of the drum surface areas.

(4) During grinding operations, no greater thickness of metal than E may be removed from the brake drum either locally or circumferentially. The minimum permissible wall thickness is shown in column F and the maximum reground diameter is stated in column G. The figure in this column will only be reached if the figure before grinding is that given in Column B.

(5) The diameter of the spigot bore must not be less than the figure given in column H.

14. In classifying a drum, consideration must be given to any previous reconditioning that may have been effected. A reconditioned drum must be stamped with the RP No. followed by a figure denoting the greatest amount of metal, in thousandths of an inch, which has been removed locally or circumferentially. This code must be stamped on the drum nearest the most reduced locality. If the drum has been ground to the maximum permissible diameter the symbol "D. MAX." should follow the RP stamping.

RESTRICTED

up clamp has
e gauge must
e revolutions
ial readings
-circumferen-
the centre
0 3/4 in. from

es 2 and 3
termining
viceable,
vice, and

further
minimum
from the

ed:—

not in
mn B.

ot less
2.

gauge
mini-
t not
This
ence
5 in.

ter
ved
m-
all
he
in
l
at

st

Brake drum grinding

15. Drums which will be fit for further service after grinding, must have their maximum and minimum diameters clearly marked at the appropriate locations on the drum surface. Altogether no fewer than four readings should be marked at 90 deg. positions to facilitate the mounting of the drum for grinding.
16. For the grinding operation the drum must be clamped by the mounting flange to a face plate. The clamp bolts must be located as near as possible to the drum retaining bolt holes and, to restore concentricity, the location of the drum on the face plate must be such that the dial test indicator readings are identical to those noted in the distortion check.
17. An alternative and more satisfactory method of mounting is to use an aircraft wheel as a jig, with the hub accurately centred on

A.P.2337, Vol. 6, Sect. 1, Chap. 1, App. 2 (A.L.35)

the grinder. The drum could then be mounted in the normal way in the adapted wheel.

18. Before grinding commences, the operator must observe the location of the minimum diameter and must operate his machine so that not more than E in. of metal is removed from that spot and a final drum diameter not greater than G in. is obtained. If an all-round clean up of 0.005 in. cannot be achieved or if the operator is unable to remove localised scores or corrosion within the limits stated, the drum must be rejected as unrepairable.
19. As a precaution against removing more metal than is defined in E, operators should make a precautionary check of the drum wall thickness; this must not fall below the given limit F.
20. The grinding operation is critical and the operator must produce a 15 to 20 micro-inch finish.

2
55

TABLE I
CENTRAL LIBRARY
MINISTRY OF AVIATION
BRAKE DRUM CLEARANCES AND
PERMISSIBLE DISTORTION LIMITS

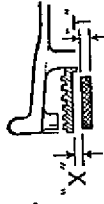

Wheel Part No.	Brake Unit Part No.	Lining material Code No. or Part No.	Lining thickness "r"		Worn linings (minimum permissible) (in.)	Minimum with used drum (in.)	Feeler clearance "X"		Maximum permissible dial gauge variation on used drums (in.)
			New linings (nominal) (in.)	Worn linings (minimum permissible) (in.)			With new drum	Min. (in.)	
AH.828	AHO.5785	*23	0.268	—	—	0.020	0.045	0.031	0.040
AH.851	AHO.5785	*23	0.268	—	—	0.020	0.045	0.031	0.040
AH.2004	AHO.5595/26	*23	0.284	—	—	0.025	0.045	0.031	0.050
AH.2016	AHO.1827	*23	0.284	—	—	0.020	0.045	0.031	0.040
AH.2061	AHO.1428/17	*23	0.271	—	—	0.020	0.045	0.031	0.040
AH.2074	AHO.2407	*23	0.256	—	—	0.030	0.064	0.045	0.060
AH.2106	AHO.1827/18	*23	0.284	—	—	0.020	0.045	0.031	0.040
AH.2154	AH.8095/3	*23	0.291	—	—	0.020	0.045	0.031	0.040
AH.2221	AH.1027/26	*23	0.354	—	—	0.025	0.045	0.031	0.050
AH.2233	AH.10231	*23	0.364	—	—	0.030	0.064	0.045	0.060
AH.2238	AH.8057/1	*23	0.391	—	—	0.030	0.064	0.045	0.060
AH.2238	AH.10227/26	*23	0.391	—	—	0.030	0.064	0.045	0.060
AH.8049	AH.8050	*23	0.256	—	—	0.030	0.064	0.045	0.060
AH.8053	AH.10227	*23	0.391	—	—	0.030	0.064	0.045	0.060
AH.8064	AH.8065	*23	0.371	—	—	0.025	0.045	0.031	0.050
AH.8079	AH.8129	*23	0.286	—	—	0.025	0.045	0.031	0.050
AH.8093	AH.8094/1	*23	0.297	—	—	0.025	0.045	0.031	0.050
AH.8137	AH.8138	21	0.505	—	0.405	0.025	0.045	0.031	0.040
AH.8152	AHO.5785	*23	0.268	—	—	0.020	0.045	0.031	0.040
AH.8176	AH.8177/18	21	0.492	—	0.392	0.020	0.045	0.031	0.040
AH.8176	AH.8439/1	21	0.492	—	0.392	0.025	0.045	0.031	0.050
AH.8208	AH.8209/1	21	0.550	—	0.450	0.025	0.045	0.031	0.050
AH.8208	AH.8209/20	21	0.550	—	0.450	0.025	0.045	0.031	0.050
AH.8208	AH.8209/21	21	0.550	—	0.450	0.020	0.045	0.031	0.040
AH.8218	AH.8219/1	21	0.460	—	0.360	0.020	0.045	0.031	0.040
AH.8218	AH.8902	AHO.25500	0.450	—	0.350	0.020	0.045	0.031	0.060
AH.8268	AH.8269/1	21	0.505	—	0.405	0.030	0.064	0.045	0.050
AH.8310	AH.8311	21	0.495	—	0.395	0.025	0.045	0.031	0.050
AH.8312	AH.8313/1	21	0.505	—	0.405	0.025	0.045	0.031	0.050
AH.8365	AH.8421	21	0.505	—	0.405	0.025	0.045	0.031	0.040
AH.8375	AH.8377/1	21	0.492	—	0.392	0.020	0.045	0.031	0.040
AH.8379	AH.8209	21	0.550	—	0.450	0.025	0.045	0.031	0.050

not applicable

RESTRICTED

TABLE I—Cont.

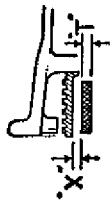

PERMISSIBLE DISTORTION LIMITS
BRAKE DRUM CLEARANCES AND

Wheel Part No.	Brake Unit Part No.	Lining material Code No. or Part No.	Lining thickness "T"		Minimum with used drum (in.)	Feeler clearance "X"		Maximum permissible dial gauge variation on used drums (in.)
			New linings (nominal) (in.)	Worn linings (minimum permissible) (in.)		Max. (in.)	Min. (in.)	
AH.8391	AH.8392/1	21	0.505	0.405	0.030	0.045	0.031	0.040
AH.8405	AH.8269/1	21	0.505	0.405	0.030	0.064	0.045	0.060
AH.8406	AH.8407/1	21	0.505	0.405	0.020	0.045	0.031	0.040
AH.8410	AH.8057/1	*23	0.391	---	0.030	0.064	0.045	0.060
AH.8419	AH.8377/1	21	0.492	0.392	0.020	0.045	0.031	0.040
AH.8435	AH.8238/1	21	0.505	0.405	0.025	0.045	0.031	0.050
AH.8438	AH.8209	21	0.550	0.450	0.025	0.045	0.031	0.050
AH.8444	AH.8132/20	21	0.550	0.450	0.025	0.045	0.031	0.050
AH.8519	AH.8377/1	21	0.492	0.392	0.020	0.045	0.031	0.040
AH.8563	AH.8269/1	21	0.505	0.405	0.030	0.064	0.045	0.060
AH.8725	AH.8726	30	0.625	0.525	0.025	0.045	0.031	0.050
AH.8736	AH.8138	21	0.505	0.405	0.025	0.045	0.031	0.050
AH.8792	AH.8269	21	0.505	0.405	0.030	0.064	0.045	0.060
AH.8965	AH.8269	21	0.505	0.405	0.030	0.064	0.045	0.060
AH.8980	AH.8269	21	0.505	0.405	0.030	0.064	0.045	0.060
AH.9139	AH.9140	21	0.505	0.405	0.020	0.045	0.031	0.040
AH.9139	AH.50329	AHO.25169	0.500	0.400	0.020	0.045	0.031	0.040
AH.10019	AHO.5480/28	AHO.25169	0.500	0.400	0.020	0.045	0.031	0.040
AH.10020	AHO.5446/1	*23	0.271	---	0.020	0.045	0.031	0.040
AH.10025	AH.8194/1	*23	0.284	---	0.020	0.045	0.031	0.040
AH.10025	AH.8411/1	*23	0.280	---	0.020	0.045	0.031	0.040
AH.10158	AH.10160/24	*23	0.317	---	0.020	0.045	0.031	0.040
AH.10245	AH.8010/1	*23	0.359	---	0.030	0.064	0.045	0.060
			0.291	---	0.020	0.045	0.031	0.040

* Because Code 23 linings wear much longer than Code 21 linings, they will invariably be unserviceable through burning or oil contamination before they become appreciably worn. No rejection limits are therefore given for Code 23 linings.

RESTRICTED

Table 2
Brake drum grinding limits
(Steel drums)

Wheel assy. Part No.	Brake drum Part No.	A Nom. brake drum diameter Min. recommended for service (in.)	B Max. dia. at which drum may be repaired (in.)	C Min. dia. at which drum may be repaired (in.)	D Permissible max. variation between max. dia. and min. dia. (in.)	E Max. thickness of metal to be removed (in.)	F Min. wall thickness (in.)	G Max. Reground dia. (in.)	H Min. dimension of spigot bore dia. (in.)
AH.8176	AHO.17685	8-750	8-760	8-710	0-040	0-025	0-345	8-770	6-750
AH.8208	AHO.17688	11-500	11-510	11-460	0-040	0-025	0-345	11-520	9-000
AH.8375	AHO.18689	8-750	8-760	8-710	0-040	0-025	0-345	8-770	6-750
AH.8391	AHO.18800	10-500	10-510	10-460	0-040	0-025	0-345	10-520	8-750
AH.8406	AHO.18981	9-250	9-260	9-210	0-040	0-025	0-345	9-270	7-500
—	AHO.20798	14-000	14-010	13-978	0-022	0-016	0-234	14-020	10-750
AH.8137	AHO.17710	13-500	13-510	13-460	0-040	0-025	0-406	13-520	11-500
AH.2238	AHO.3793	15-750	15-760	15-710	0-040	0-025	0-124	15-770	—

RESTRICTED

Table 3
Brake drum grinding limits
(Bi-metal drums)

Wheel assy. Part No.	Brake drum Part No.	A Nom. brake drum diameter Min. recommended for service (in.)	B Max. dia. at which drum may be accepted for reclaim (in.)	C Min. dia. at which drum may be accepted for reclaim (in.)	D Permissible max. variation between max. dia. and min. dia. (in.)	E Max. thickness of metal to be removed (in.)	F Min. wall thickness (in.)	G Max. Reground dia. (in.)	H Min. dimension of spigot bore dia. (in.)
AH.9596	} AHO.19491	19-500	19-510	19-460	0-040	0-025	0-297	19-520	16-375
AH.50159		8-750	8-760	8-710	0-040	0-025	0-472	8-770	6-750
AH.8519	AHO.20097	11-250	11-260	11-210	0-040	0-025	0-495	11-270	9-125
AH.8725	AHO.22528	11-500	11-510	11-460	0-040	0-025	0-347	11-520	9-625
AH.9073	AHO.25007	9-500	9-510	9-460	0-040	0-025	0-316	9-520	7-500
AH.9139	AHO.25185	19-500	19-510	19-460	0-040	0-025	0-548 to top of waves	19-520	16-375
AH.9505	AHM.1667	8-750	8-760	8-710	0-040	0-025	0-272	8-770	6-750
AH.9415	AHO.22975	8-750	8-760	8-710	0-040	0-025	0-272	8-770	6-750
AH.9379	AHO.26495	8-750	8-760	8-710	0-040	0-025	0-272	8-770	6-750

RESTRICTED

Appendix 3

PREPARATION AND APPLICATION OF EPOXY RESIN JOINTING AND FILLING MIXTURES

Introduction

1. Epoxy resin may be listed as a liquid jointing compound between mating faces, or as a paste to build up worn or damaged surfaces such as the Maxaret tracks on some main wheels. Preparation and application of the mixtures must be carried out in accordance with the following instructions. When called for, details will be given in the relevant subject, of permitted areas of application, associated procedures and the mixture reference number.

Preparation

2. Remove the paint, degrease the unit and apply the appropriate protective treatment (Brush Alocrom 1200 or Selenious acid solution) as described in Vol. 1, Book 1, Sect. 1, Chap. 1.

3. Where corrosion is present it must be removed by vapour blasting (followed by an

adequate drying process carried out at 100 to 120 deg. C.), or by grit blasting as laid down in Vol. 1, Book 1, Sect. 1, Chap. 1.

Epoxy resin mixtures

4. Ingredients as supplied by CIBA (A.R.L.) Ltd., Duxford, Cambridge, England. Tins must be airtight and stored in a cool place. Do not allow the mixture or ingredients to become contaminated.

Caution . . .

As Hardener and the uncured mixture of Hardener and Resin may be injurious to the skin observe the precautions laid down by the manufacturer.

5. The following table details the correct proportion of ingredients, which must be mixed at room temperature and stirred thoroughly. The usable life is considerably reduced when large quantities are mixed.

Process No.	Mixture	Proportions		Usable life of mixture
		Parts by weight	Parts by volume	
1	Araldite AV.121	Araldite 100		1 to 1½ hours at room temperature
	Hardener 951	Hardener 4 to 4½		
2	Araldite MY.753	Araldite 100	Araldite 100	3 hours at 20 deg. C. 1 hour at 40 deg. C.
	Hardener HY.951	Hardener 8 to 10	Hardener 9½ to 12	

RESTRICTED

Application

6. Ensure that the prepared surfaces are clean and free from grease and moisture. Apply the mixture with a spatula or knife. Remove excess mixture with a knife dipped in acetone. When used for jointing, build up a neat fillet of mixture at exposed faces.

Curing period

7. Maximum strength of a joint or filling will be achieved after the curing period detailed in the appended table. Any final machining operations detailed for the relevant subject must be carried out after the curing period has expired.

Process No.	Mixture	Curing period
1	Araldite AV.121 and Hardener HY.951	24 hours at 20 deg. C.
2	Araldite MY.753 and Hardener HY.951	2 to 3 hours at 60 deg. C. or 10 to 20 min. at 100 deg. C.

RESTRICTED

F.S./1

Appendix 4

RENEWAL OF WIRE THREAD INSERTS
IN DRIVE BLOCK SCREW HOLES

(MAIN WHEELS AH.50439, AH.51337)

Scheme

1. This repair may be used on main wheels in which the drive block screws have become loose. It is intended as an interim repair stage where damaged wire thread insert(s)

have been discovered during examination for limits of looseness before RP.423 is required.

2. The following new parts are required: -

Ref. No.	Part No.	Description	No. off
	AS.4921/71 or AS.4947/71	Cross wire thread insert $\frac{1}{4}$ in. Whitworth \times 0.37 in. long (notched)	As required
		Cross wire thread insert $\frac{5}{16}$ in. Whitworth \times 0.37 in. long (notched)	As required
27A/4071	AHO.38001	Drive block screw $\frac{1}{4}$ in. B.S.W.	As required
27A/N.I.V.	AHO.38206	Drive block screw $\frac{5}{16}$ in. B.S.W.	As required
27A/4072	0 dia. \times $\frac{1}{4}$ in.	Screw, Parker Kalon, headless Type U	As required
	AHO.38156	Dowel screw - (Wheel AH.50439 only)	As required

Note . . .

There are three drive block dowel screws used also with the normal drive block screws for retaining the inner drive blocks of wheel AH.50439. Care must be taken to ensure that if one of these is removed in

the repair, it is replaced by a similar dowel screw.

3. The following special tools are required to carry out this repair:—

Ref. No.	Part No.	Description	No. off
		Cross insert tap (for $\frac{1}{4}$ in. Whitworth cross wire thread inserts)	1
		Cross insert tap (for $\frac{5}{16}$ in. Whitworth cross wire thread inserts)	1
AO.70285		Thread insert tool (for $\frac{1}{4}$ in. Whitworth cross wire thread inserts)	1
AO.70283		Thread insert tool (for $\frac{5}{16}$ in. Whitworth cross wire thread inserts)	1

RESTRICTED

4. A requirement is selenious acid crystals (Ref. 33C/2200748) refer to A.P.119A-0600-1, Sect. 3, Chap. 6.

Method of repair

5. (1) Carefully remove a broken or damaged wire thread insert from its housing in the wheel. Use a removal key tool (thread insert tool AO.70285 or AO.70283 will do) but first bend the top coil of the insert inwards to form a tang.

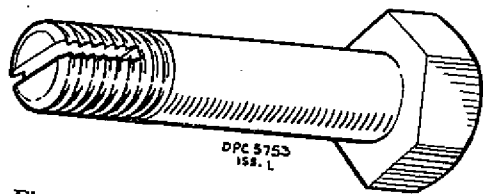

Fig. 1 Locally made inserting/removal key tool

Note . . .

An inserting/removal tool can be locally manufactured from a 1 in. or 1½ in. long hexagon bolt, of an appropriate size, that will just fit with clearance inside the fitted insert. Use with a wrench and socket spanner.

(2) Examine the tapped threads for damage.

(3) Chase out the thread with the appropriate size special plug tap.

(4) Remove the swarf with a low pressure compressed air blast, ensure the hole is thoroughly dry.

(5) Treat the exposed metal with selenious acid solution as detailed in A.P.119A-0600-1, Sect. 3, Chap. 6.

(6) Refit a new wire thread insert (refer to A.P.1464B, Vol. 1, Part 2, Sect. 6, Chap. 23, para. 4 to 6).

(7) Refit the old drive block. Before fitting clean away the old pigmented oil varnish jointing compound (Ref. 33H/2202110) and apply the new compound (Ref. 33H/2202110) to the mating surfaces of the drive block. Secure the drive block using the new screws.

(8) Check that a 0.0015 in. feeler gauge cannot be inserted between the wheel and the underside of the drive block.

(9) Drill with a No. 51 (0.067 in.) drill, new locking holes at different locations from the originals, through the slots in the screw heads and into the drive blocks.

(10) Drive in the locking screws until they are flush with the surface of the drive block.

RP 2

REPAIR TO HOUSING FOR WHEEL BEARING

Equipment required

Lathe: Herbert No. 9B or its equivalent.

The speed for all turning operations to be approximately 100 r.p.m.

Press: Hydraulic or mechanical; press loading, 5 tons maximum.

Bearing punch (press tool), Part No. RT/3, for pressing in liners.

Selenious acid solution: 2 oz. Selenious acid crystals, dissolved in 1 pint of water.

New Parts: Two liners for the bearing housings, Part No. RP2/5, to be provided under Unit arrangements (refer to Table I).

WARNING

Selenious acid, crystals or solution, must not be allowed to contact the skin

Description

1. Due to various causes, the housings for the wheel bearings often become enlarged to such an extent that the outer track of one or both bearings creep. When this condition arises, both bearing housings are to be enlarged and steel liners fitted to restore the bearing housings to their original dimensions.

Method of repair

2. (1) Dismantle and degrease the wheel.
- (2) Mount the wheel casting in a lathe so so that the chuck-jaws locate on the outer face of the rim at the side on which the loose flange fits. It must then be set up so that the hub runs true in both the vertical and the horizontal plane. To check for truth, apply a dial test indicator to the tapered surface near the end of the nave: the maximum D.T.I. variation permitted is 0.002 in.
- (3) Machine the bearing housing to the dimensions given in fig. 1. Check against drawing requirements.
- (4) Reverse the wheel in the lathe and adjust the chucks to grip the fixed flange; set up as described in (2) and repeat (3) at the other bearing position.
- (5) Clean the machined surfaces and repair the chromate film (A.P.2656A, Vol. 1, Sect. 5, Chap. 2 refers).

(6) Apply a thin coating of pigmented varnish, jointing compound (Stores Ref. 33C/126A) to the machined surfaces of each housing.

(7) Position the flanged end of a steel liner RP2/5 in the mouth of either housing and ensure that its face is square to the horizontal axis of the hub. Support the wheel, keeping the rim clear of the press bed, by placing a parallel block between the bed of the press and the adjacent nave, position a press tool RT/3 (see Table 2) in the liner, and operate the press to position the liner (max. press load, 5 tons). There must be no gap between the inner end of the liner and the abutment face of the housing; check this with a 0.0015 in. feeler gauge. Reverse the wheel and repeat at the other side of the wheel.

Note . . .

If a modification introducing an improved type of oil seal is to be incorporated together with this repair, do not proceed with operation 8 and 9, but refer to RP3 for detailed instructions and illustrations of the combined operations.

(8) Set the wheel up as described in (2) and machine the fitted liner to all dimensions, except "B", given on RP2/6 (fig. 2). The finished bore of the liner must be smooth and free from tool marks.

(9) Set the wheel up as described in (4) and machine the other liner to all dimensions, except "A", given on RP2/6. The bore of the liner must be smooth and free from tool marks.

Inspection

3. The repair must be to the satisfaction of the supervising inspector A.I.D., C.I.O./N.A.I., or C.I.O./A.I.S.

Identification

4. After satisfactory completion of the repair, "RP2" is to be stamped immediately below the Assembly Issue No. on each face of the wheel, with $\frac{1}{8}$ in. metallic stamps and the indentations must be painted with selenious acid solution.

RESTRICTED

threads for
with the
ap.
v pressure
ie hole is
selenious
P.119A-
refer to
Chap.
Before
ed oil
ref.
n-
ating
the

uge
and
ill,
ns
in
s.
il
e

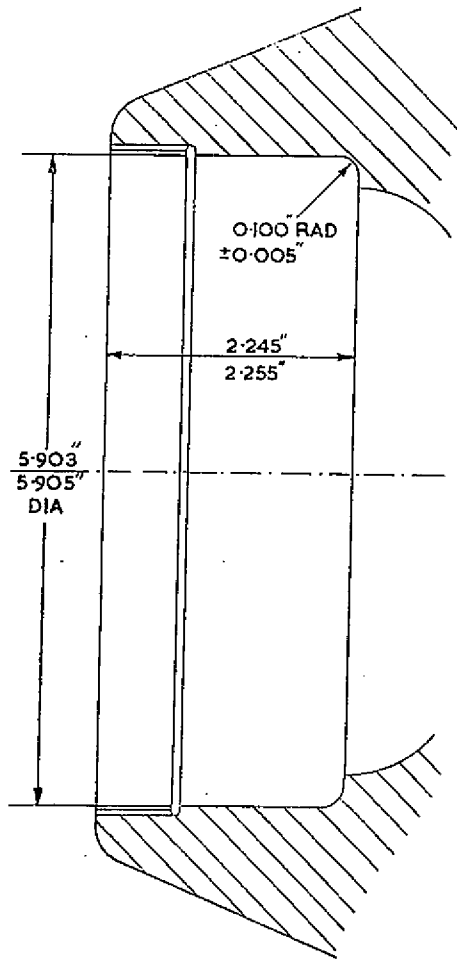

RP2/4

Fig. 1. Dimensions for machining bearing housing

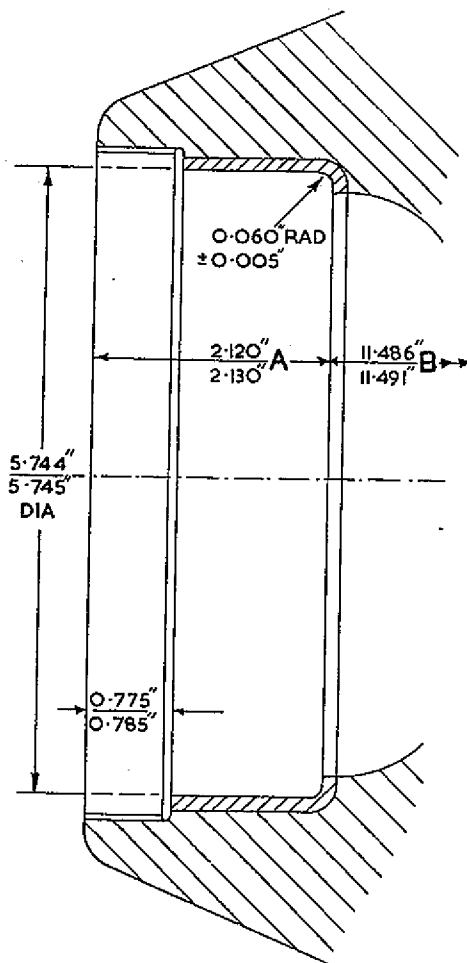

RP2/6

Fig. 2. Liner in position. Dimensions for final machining

F
 3004
 274
 303
 3005

RESTRICTED

R P 3

REPAIR BY FITTING AN OIL SEAL OF IMPROVED TYPE

Requirements

Lathe: Herbert No. 9B or its equivalent.
Speed for all turning operations, 100 r.p.m. max. to avoid excessive generation of heat and ignition of electron swarf.

Vertical milling machine: Cincinnati No. 3 or its equivalent. The operating speed for milling operations should be 500 to 1500 r.p.m.

Selenious acid solution: 2 oz. selenious acid crystals dissolved in one pint of water.

a later date to apply RP2. In these instances the fact that the nave length has been reduced must be considered, and allowances made, when the hub is machined to accommodate the liner.

Operations

2. When this repair is being effected simultaneously with RP.2, operations 1 to 7 inclusive, of that repair scheme must be completed prior to commencing the following operations:—

Machining the inboard nave and liner

- (1) Mount the hub casting in a lathe with the chuck-jaws located on the external face of the rim and set the wheel up so that the hub runs true; check with a dial test indicator applied to the tapered face near the end of the nave, the maximum D.T.I. variation permitted is 0.002 in.
- (2) Machine the fitted liner to all relevant dimensions, except B, given on RP3/6 (fig. 1); it is essential that Dimension A is obtained in the first machine operation as this provides a datum face from which measurements are taken during subsequent operations. The bore of the liner must be smooth and free from tool marks.
- (3) Machine nave to all relevant dimensions given on RP3/6.

Machining the outboard nave and liner

- (4) Reverse the wheel casting in the lathe with the chuck-jaws gripping the fixed flange and set up as described in (1).
- (5) Machine the liner to all relevant dimensions except A, given on RP3/6 (fig. 1). Dimension B is from the datum face of the inboard liner to the corresponding face of the outboard liner. This must be obtained in the first operation and then used as the datum face for the remaining dimensions.
- (6) Machine the nave to all relevant dimensions given on RP3/6 (fig. 1).
- (7) Check that all dimensions are to drawing requirements.

AL10

3004
2747
3003
3005

Part No.	Nomenclature	No. Off
AHO.28081	Oil seal housing	2
AHO.20942	Oil seal	2
AHO.19257	Circlip	2
AHO.18822	Sealing ring	2

WARNING

Selenious acid, crystals or solution, must not be allowed to contact the skin

Description

1. This repair scheme, which also constitutes a modification, allows wheels, which are unserviceable due to damaged threads in the seal housing or the total complement of drillings for grub screws having been reached, to be repaired. The repair consists of reducing the overall width of the hub by approximately half an inch, enlarging the seal housing in diameter, milling the face of the nave, and fitting an improved type of oil seal. It may be effected either independently or in conjunction with the repair scheme RP2. Dunlop Mod. Numbers have been allotted to the relevant wheels and the drawing issue numbers have been raised accordingly; details are given in the following Table:—

Main wheel Part No.	AH.8137	AH.8435	AH.8736	AH.9504
Mod. No.	1855	1856	1373	1372
New Issue No.	15	7	7	4

Note. . .

If the issue No. of the wheel has been raised by the incorporation of this repair and RP2 has not been applied, it may become necessary at

RESTRICTED

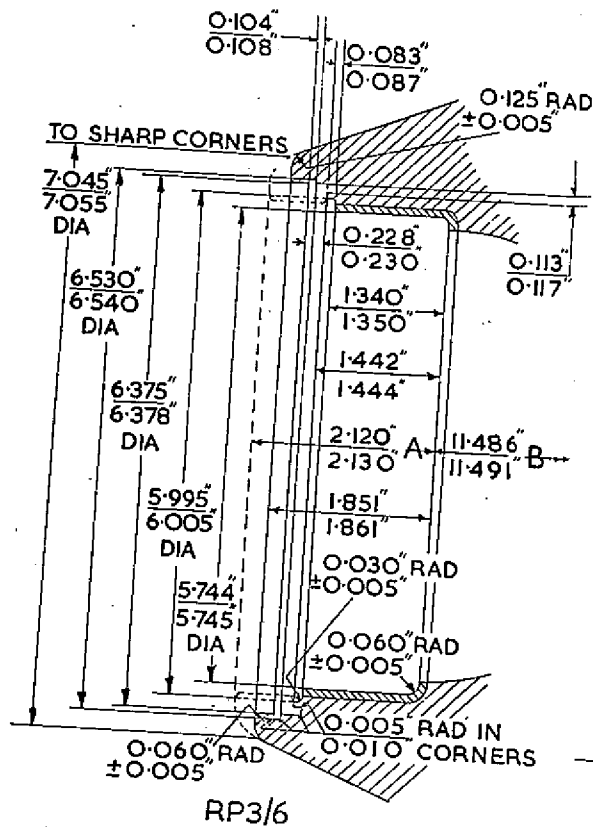

Fig. 1. Dimensions for machining hub together with liner

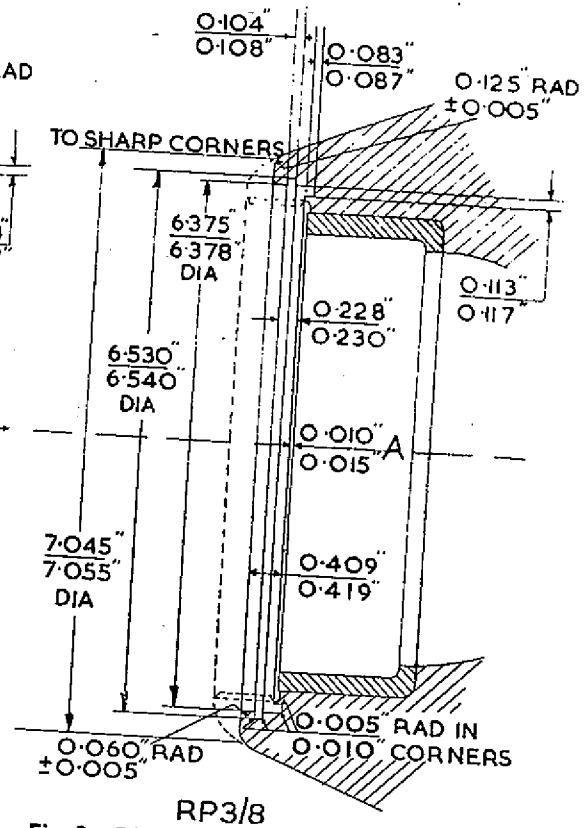

Fig. 2. Dimensions for machining hub with outer track of bearing in position

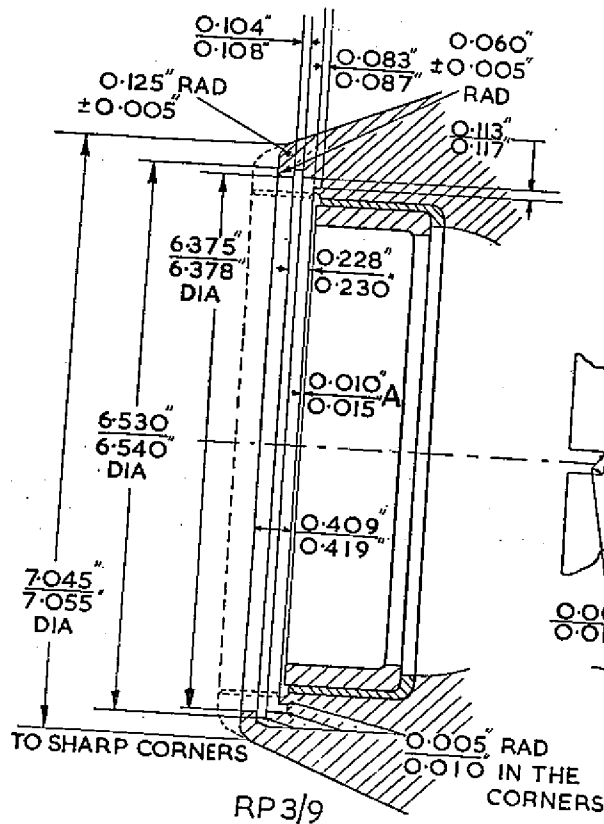

Fig. 3. Dimensions for machining hub with liner and outer track of bearing in position

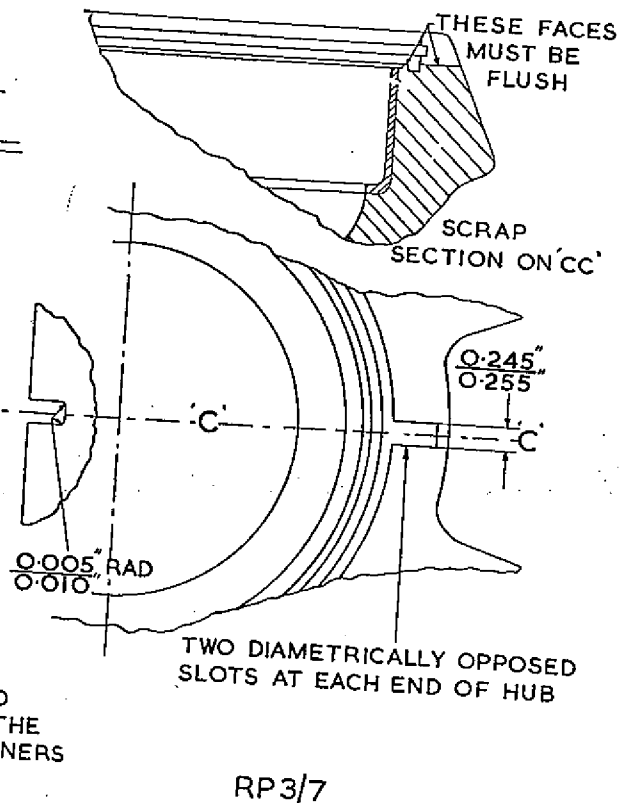
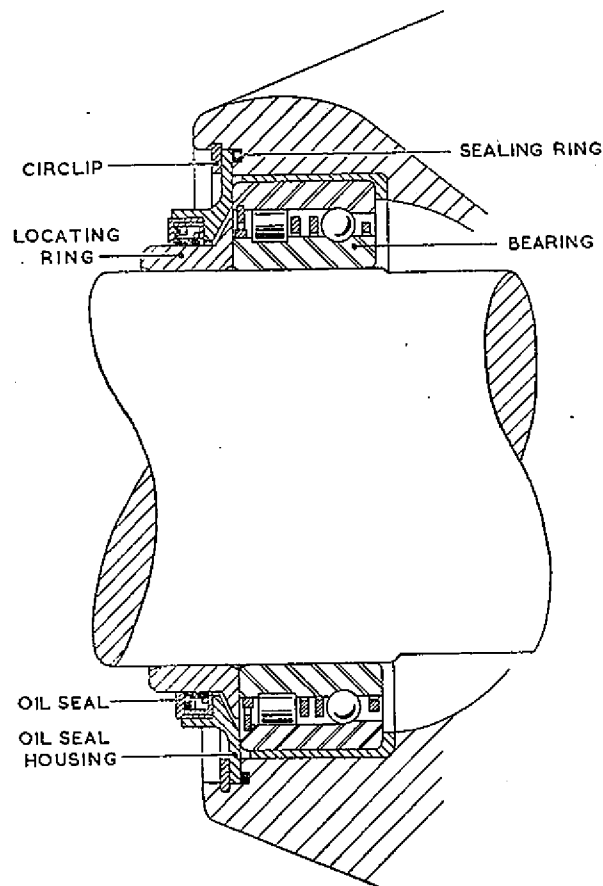

Fig. 4. Dimensions for milling slots in hub



RP3/10

Fig. 5. General arrangement of the hub nave, fitted with liner, bearing, and improved type oil seal

Milling the tenon slots

- (8) Mark off two diametrically opposed points on the end face of one nave; the circumferential position of the marking relative to the spokes is immaterial. Set the casting up horizontally on the table of a vertical miller and mill two slots as shown on RP3/7 (fig. 4). It is essential that the base of the slots is perfectly flush with the end face of the sealing ring housing.
- (9) Reverse the wheel casting and repeat operation (8) at the other side of the hub.
- (10) Remove the burrs carefully and check that the slots conform to drawing requirements, then apply operation (15).

Preparing to fit improved type oil seals, with the outer track of the bearing in position

- (11) Mount and set up the wheel casting as in (1). Machine the inboard nave to the dimension A given on RP3/8 (fig. 2) to establish a datum face and then machine the nave to all other dimensions given on RP3/8.
- (12) Reverse and set up the wheel casting as in (4) and repeat (11) at the outboard nave.
- (13) Form two slots at each end of the hub as described in (8), (9) and (10).

Preparing to fit improved type oil seals, with both the liners and the outer tracks of the bearings in position

- (14) This operation is dimensionally identical with operations (11), (12) and (13).

RESTRICTED

It is illustrated in RP3/9 (fig. 3) which differs from RP3/8 (fig. 2) pictorially only; apply these operations.

- (15) Clean the machined surfaces and repair the chromate film (A.P.2656A, Vol. 1, Sect. 5, Chap. 2 refers).

Assembling

3. (1) Clean the wheel thoroughly and assemble the bearings in their respective housings.
- (2) Fit a sealing ring in the groove in the base of the recess at each end of the nave.
- (3) Coat the recess in the oil seal housings with pigmented varnish jointing compound (Stores Ref. 33C/1264) and press an oil seal into position in each.
- (4) Position a locating ring on each bearing in turn, then slide an assembled oil seal onto each and secure the assemblies by fitting a circlip in the groove at each side of the hub; complete each separately.

Identification after repair or modification

4. The new Issue No. quoted in para. 1, must be stamped on each face of the wheel. If the new Issue No. runs consecutively with the previous Issue No., delete the old No. and stamp the new No. adjacent to it. If, for

instance, a wheel marked Issue 3 has been modified by the incorporation of this repair and the new issue No. is 7, space must be left to add the intervening Issue No. when required. It is then readily observed that the intervening modifications have not been embodied as the marking would be Issue 3 7. If the next mod. raises the issue to 4 the marking would be 3 4 7 and similarly, until all mods. are embodied up to Issue 7. In addition to this, if the Issue No. has been raised as the result of repair, "RP3" must be stamped immediately below the Issue No. If RP2 has been embodied, the marking would appear 'RP2-3'. Metallic stamps, $\frac{1}{8}$ in. high, are to be used for this purpose.

Note . . .

Stamping breaks through the anti-corrosive film; this must be repaired in accordance with the instructions in A.P.2656A, Vol. 1, Sect. 5, Chap. 2.

Inspection

5. The repair must be to the satisfaction of the supervising inspector A.I.D., C.I.O./N.A.I., or C.I.O./A.I.S.

Note . . .

RP4 applies to Civil aircraft only.

RESTRICTED

RP.5

REPAIR TO HOUSING FOR WHEEL BEARING

Requirements

Lathe: Herbert No. 9B or its equivalent.

The speed for all turning operations to be approximately 100 r.p.m.

Press: Hydraulic or mechanical; press loading, 5 tons maximum.

Bearing punch (press tool): Part No. RT.3, for pressing in liners (Table 2).

Vertical milling machine: Cincinnati No. 3 or equivalent of suitable capacity, for milling extractor slots, speed 500 r.p.m.

Selenious acid solution: 2 oz. selenious acid crystals dissolved in 1 pint of water.

New parts

Part No.	Nomenclature	No. off
RP.2/5	Liners for bearing housing	2 (Table 1)

WARNING

Do not allow Selenious acid, crystals or solution, to come in contact with the skin.

Description

1. Due to various causes the housings for the wheel bearings often become enlarged to such an extent that the outer track of one or both bearings creep. When this condition arises, both bearing housings are to be enlarged and steel liners fitted to restore the bearing housings to their original dimensions.

Method of repair

- (1) Dismantle and degrease the wheel.
- (2) Mount the wheel casting in a lathe so that the chuck-jaws locate on the outer face of the rim at the side on which the loose flange fits. It must then be set up so that the hub runs true in both the vertical and horizontal plane. To check for truth, apply a Dial Test Indicator to the tapered surface near the end of the nave; the maximum D.T.I. variation permitted is 0.002 in.
- (3) Machine the bearing housing to the dimensions given on RP.5/3 (fig. 1). Check against drawing requirements.
- (4) Reverse the wheel in the lathe and adjust the chucks to grip the other flange; set up as described in (2) and repeat (3) at the other bearing position.
- (5) Degrease the freshly machined surfaces in accordance with Specification D.T.D.

911, para. 7, then paint them with selenious acid solution.

- (6) Apply a thin coating of oil varnish, specification D.T.D.369 ("Duralac" jointing compound) to the machined surfaces of each housing.
- (7) Position the flanged end of the steel liner RP.2/5 (Table 1) in the mouth of either housing and ensure that its face is square to the horizontal axis of the hub. Support the wheel, keeping the rim clear of the press-bed, by placing a parallel block of sufficient thickness between the other nave and the press-bed. Position the press tool RT.3 (Table 2) in the liner and operate the press to insert the liner (max. press load, 5 tons). There must be no gap between the inner end of the liner and the abutment face of the housing; check this with a 0.0015 in. feeler gauge. Reverse the wheel and fit the other liner in a similar manner.
- (8) Set the wheel up as described in (2) and machine the fitted liner to all dimensions, except B, given in RP.5/4 (fig. 2); the finished bore must be smooth.
- (9) Set the wheel up as described in (4) and machine the other liner to all dimensions, except A, given in RP.5/4 (fig. 2).
- (10) Set the wheel casting up on a vertical miller so that the cutter will ultimately engage the original extractor slots. Using a 0.750 in. dia. end-mill, machine the liner to conform with the extractor slots. Reverse the wheel and machine similar slots in the other liner.
- (11) Remove all burrs and paint the slots in the wheel casting with selenious acid solution.

Inspection

3. The repair must be to the satisfaction of the Supervising Inspector A.I.D., C.I.O./N.A.I. or C.I.O./A.I.S.

Identification

4. After satisfactory completion of the repair, using $\frac{1}{8}$ in. metallic stamps, stamp "RP.5" immediately below the Issue No. on each face of the wheel casting. Paint the stampings with selenious acid solution.

RESTRICTED

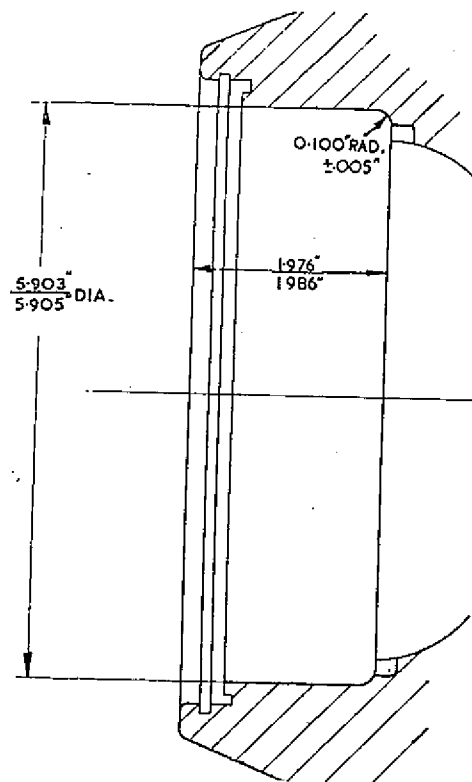

Fig. 1. Dimensions for machining bearing housing. RP.5/3

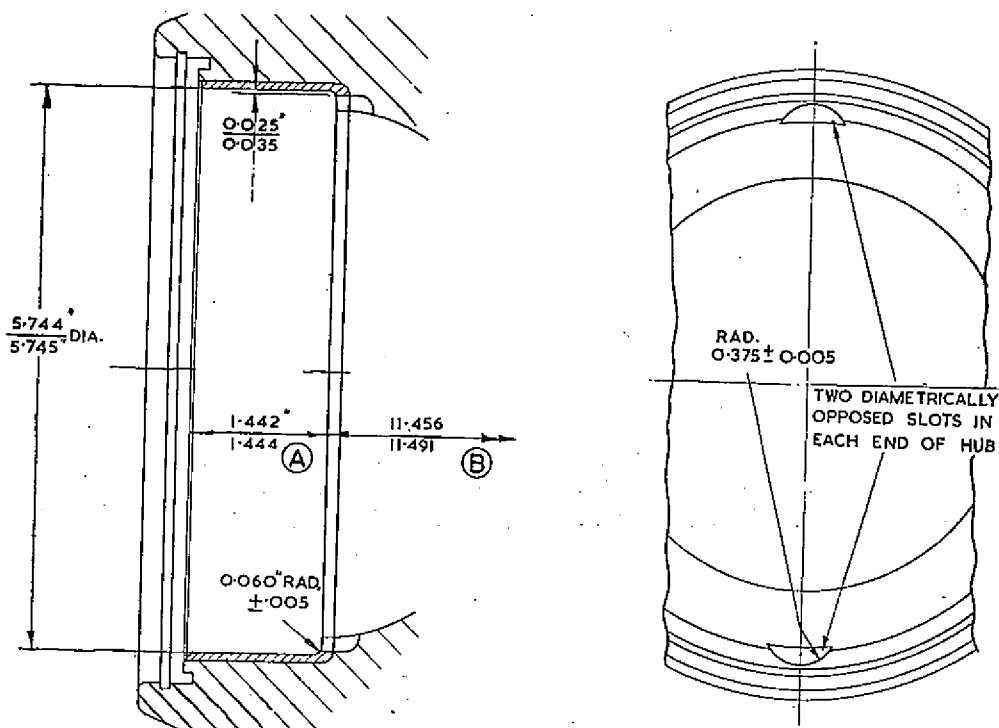

Fig. 2. Dimensions for machining fitted liner. RP.5/4

RESTRICTED

RP7

REPAIR TO HOUSING FOR WHEEL BEARINGS

Requirements

Lathe: Herbert No. 9B or its equivalent. The speed for all turning operations to be approximately 100 r.p.m.

Press: Hydraulic or mechanical; press loading inboard liner 2½ tons max., outboard liner 3½ tons max.

Press tools: Bearing liner punch, Part No. RT/14 (Table 2).

Selenious acid solution: 2 oz. Selenious acid crystals dissolved in one pint of water.

New parts: Liner, Part No. RP.7/6A for inboard bearing housing, and liner, Part No. RP.7/6B for outboard bearing housing. The

Liners (Table 1) to be provided under Unit arrangements.

WARNING

Selenious acid crystals or solution must not be allowed to come into contact with the skin.

Introduction

1. Due to various causes the housings for the wheel bearings may become enlarged to such an extent that the outer track of one or both bearings creeps. When this condition arises both bearing housings are to be enlarged, and steel liners are to be fitted to restore the housings to their original dimensions.

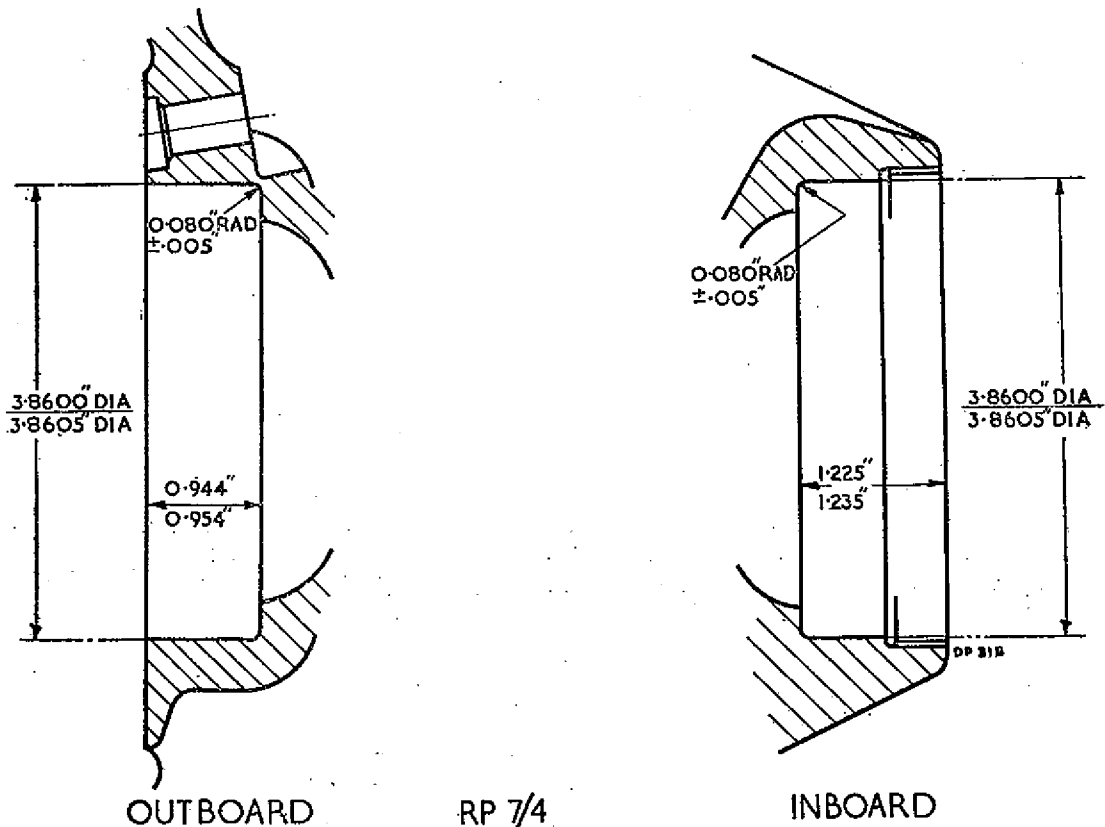

Fig. 1. Dimensions for machining bearing housings

RESTRICTED

Method of repair

2. (1) Dismantle and degrease the wheel.
- (2) Mount the wheel casting in a lathe so that the chuck-jaws locate on the rim at the side on which the loose flange fits. It must then be set up so that the hub runs true in both the vertical and the horizontal planes. To check for truth apply a dial test indicator to the hub of the bearing housing; the maximum D.T.I. variation permitted is 0.002 in.
- (3) Machine the bearing housing at the fixed flange end of the wheel to the dimensions given in RP.7/4 (fig. 1). Check against drawing requirements.
- (4) Reverse the wheel in the lathe and adjust the chucks to grip the fixed flange, set up as described in (2) and machine the outboard housing at the loose flange end of the wheel to the dimensions given in RP.7/4 (fig. 1). Check against drawing requirements.
- (5) Clean the machined surfaces and repair the chromate film (*A.P.2656A, Vol. 1, Sect. 5, Chap. 2, refers*).
- (6) Apply a thin coating of pigmented varnish jointing compound (*Stores Ref. 33C/1264*) to the machined surfaces of each bearing housing.
- (7) Position the flanged end of the steel liner, RP.7/6A, in the mouth of the inboard bearing housing and ensure that it is perfectly square to the horizontal axis of the hub.
- (8) Support the wheel and keep the rim clear of the press bed by placing a parallel block between the bed of the press and the adjacent wheel nave. The block must only contact the centre boss of the wheel and in no circumstances must it touch the outer flange. Failure to comply with this instruction may result in strain to the hub casting. Position a press tool RT/14 in the liner and operate the press up to a max. of 2½ tons to press the liner home in the housing. There must be no end gap between the inner end of the liner and the abutment face of the housing; check this with a 0.0015 in. feeler gauge. Reverse the wheel and repeat the operation at the other side of the wheel using steel liner RP.7/6B and a press loading of up to 3½ tons.
- (9) Position the wheel in the lathe and set up as in (4), and machine the face of the outboard liner to finish flush with the end face of the hub. The dimension A must next be machined to establish the datum face from which the subsequent machining may be carried out. Machine the liner to all relevant dimensions except

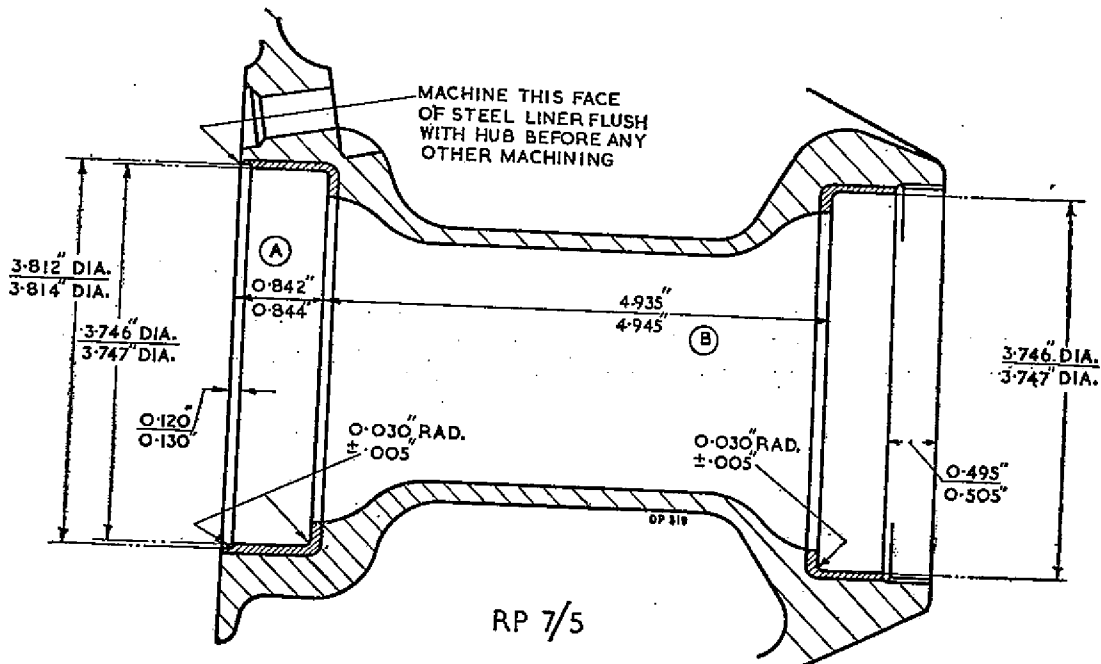

Fig. 2. Dimensions for machining fitted liners

RESTRICTED

This leaf issued with A.L. No. 15, August, 1953

A.P.2337, Vol. 6, Sect. 1, Chap. 1

B given in RP.7/5 (*fig. 2*) appropriate to the outboard liner. The bore must be smooth and free from tool marks. Check against drawing requirements.

- (10) Reverse the wheel in the lathe and set up as in (2). Machine the inboard liner to all relative dimensions, including B, given in RP.7/5 (*fig. 2*). The bore must be perfectly smooth and free from tool marks. Check against drawing requirements.

Inspection

3. The repair must be to the satisfaction of the supervising inspector A.I.D., C.I.O./N.A.I., or C.I.O./A.I.S.

Identification

4. After the satisfactory completion of the repair use $\frac{1}{8}$ in. metal stamps to mark "RP7" below the assembly Issue No. on the wheel. After marking the wheel, paint the indentations with selenious acid solution.

RESTRICTED

R.P.9

REPAIR TO HOUSING FOR WHEEL BEARING

Main landing wheels, Part Nos. AH.8137
Issue No. 15 & Sub., AH.8435 Issue No. 7 & Sub.,
AH.8736 Issue No. 7 & Sub., AH.9372 Issue No.
3 & Sub., AH.9467 Issue No. 6 & Sub., AH.9504
Issue No. 4 & Sub.

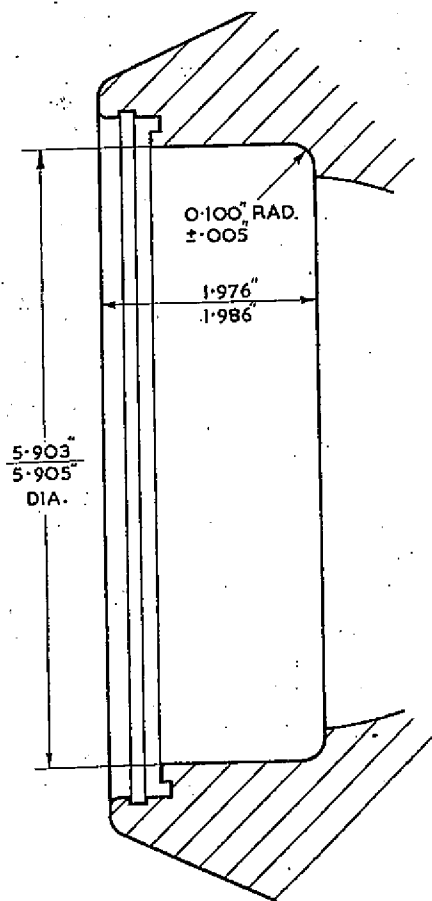

RP9/3

Fig. 1. Dimensions for machining the Bearing housings

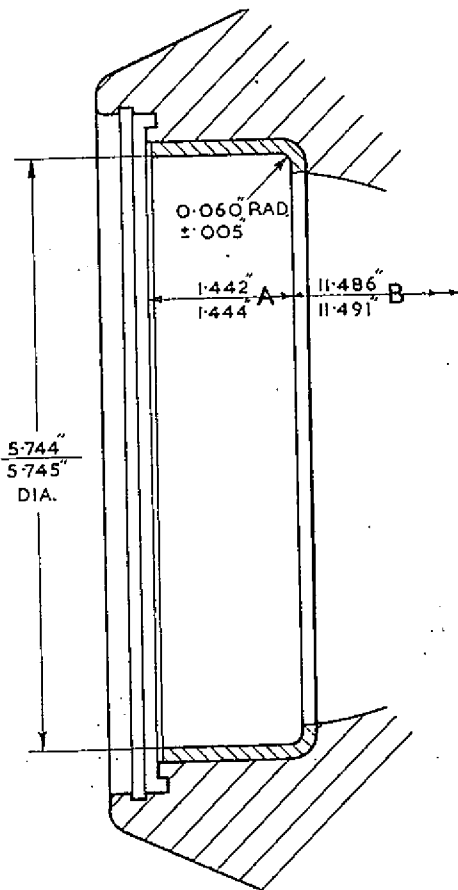

RP9/4

Fig. 2. Dimensions for machining fitted liners

RESTRICTED

Note . . .

Wheels marked with the above issue numbers and additionally identified "R.P.2" already incorporate bearing liners. This repair scheme therefore will not apply.

Equipment required

Lathe: Herbert No. 9B or equivalent. The speed for all turning operations to be approximately 100 r.p.m.

Press: Hydraulic or mechanical; press load 5 tons maximum.

Bearing punch: Press tool Part No. RT/3 (Table 1) for pressing in liners.

Selenious acid solution: 2 oz. selenious acid crystals dissolved in one pint of water.

New parts

Bearing liners: Two liners Part No. RP2/5 (Table 1) to be provided under unit arrangements.

WARNING

Selenious acid, crystals or solution, must not be allowed to contact the skin.

Description

1. Due to various causes, the housings for the wheel bearings ~~often~~ ^{may} become enlarged, resulting in a slack fit and subsequent creeping of the bearing outer track. When this condition arises, both bearing housings are to be enlarged and steel liners fitted to restore the bearing housings to their original dimensions.

Method of repair

2.

- (1) Dismantle and degrease the wheel.
- (2) Mount the wheel casting in a lathe so that the chuck jaws locate on the outer face of the rim at the end on which the loose flange fits. The hub must then be set up to run perfectly true in both the vertical and horizontal plane. To check for truth, apply a dial test indicator to the tapered surface near the end of the nave; the maximum D.T.I. variation permitted is 0.002 in.
- (3) Machine the bearing housing to the dimensions shown in RP9/3 (fig. 1). Check against drawing requirements.
- (4) Reverse the wheel in the lathe and adjust the chucks to grip the fixed

flange; set up as described in (2) and repeat operation (3) at the other bearing position.

- (5) Clean the machined surfaces and repair the chromate film (A.P.2656A, Vol. 1, Sect. 5, Chap. 2).
- (6) Apply a thin coat of compound pigmented varnish jointing (Stores Ref. 33C/1264) to the machined surfaces of each housing.
- (7) Position the flanged end of a steel liner Part No. RP2/5 (Table 1) in the mouth of either housing and ensure that its face is square to the horizontal axis of the hub. Support the wheel, keeping the rim clear of the press bed, by placing a parallel block between the other nave and the bed of the press. Position the press tool Part No. RT/3 in the liner and operate the press to position the liner (max. press load 5 tons). There must be no gap between the inner end of the liner and the abutment face of the housing; check this with a 0.0015 in. feeler gauge.
- (8) Reverse the wheel and repeat operation (7) on the other bearing housing.
- (9) Mount the wheel in the lathe with the chuck jaws locating around the fixed flange and set up as described in (2). Machine the fitted bearing liner to all dimensions except "B" as shown on RP9/4 (fig. 2). The finished bore of the liner must be perfectly smooth and free from tool marks.
- (10) Reverse the position of the wheel in the lathe, set up as described in (2) and machine the other bearing liner to all dimensions except "A" as shown on RP9/4 (fig. 2). The finished bore of the liner must be perfectly smooth and free from tool marks.

Inspection

3. The repair must be to the satisfaction of the supervising inspector A.I.D., C.I.O./N.A.I. or C.I.O./A.I.S.

Identification

4. After satisfactory completion of the repair, the letters "RP9" are to be stamped immediately below the assembly issue number on each end face of the wheel with $\frac{1}{8}$ in. high metallic stamps.

RESTRICTED

RP 11

REPAIR TO HOUSING FOR WHEEL BEARINGS

Equipment required

Lathe: Herbert No. 9B or its equivalent. The speed for all turning operations to be approximately 100 r.p.m.

Press: Hydraulic or mechanical; press loading 3 tons maximum.

Press tools: Bearing punch, Part No. RT/8, for pressing in outboard liner and bearing punch, Part No. RT/7, for inboard liner (refer to Table 2).

Vertical milling machine: Cincinnati No. 2 or its equivalent. The operating speed for milling operations should be 500 to 1,500 r.p.m.

Selenious acid solution: 2 oz. selenious acid crystals dissolved in one pint of water.

New parts.

Liner, Part No. RP11/7A, for inboard bearing housing, and liner, Part No. RP11/7B, for outboard bearing housing. The liners (Table I) are to be provided under unit arrangements.

WARNING

Selenious acid, crystals or solution, must not be allowed to come into contact with the skin.

Description

1. Due to various causes, the housings for the wheel bearings may become enlarged to such an extent that the outer track of one or both bearings creep. When this condition arises, both bearing housings are to be enlarged and steel liners fitted to restore the housings to their original dimensions.

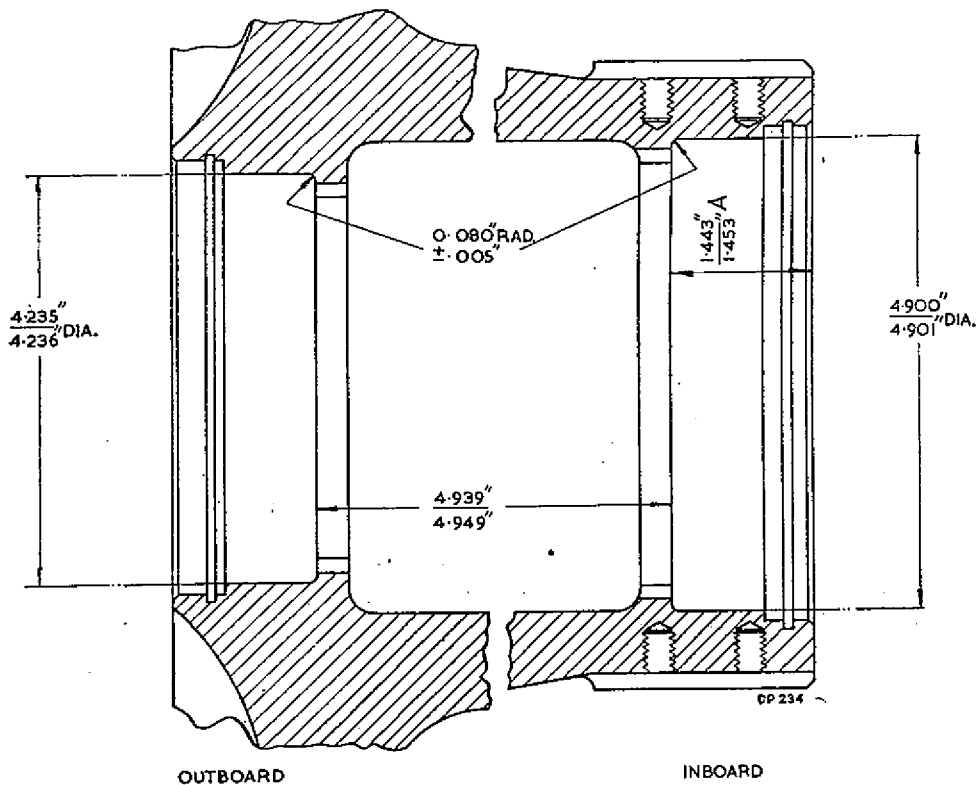

RP 11/5

Fig. 1. Dimensions for machining bearing housings

RESTRICTED

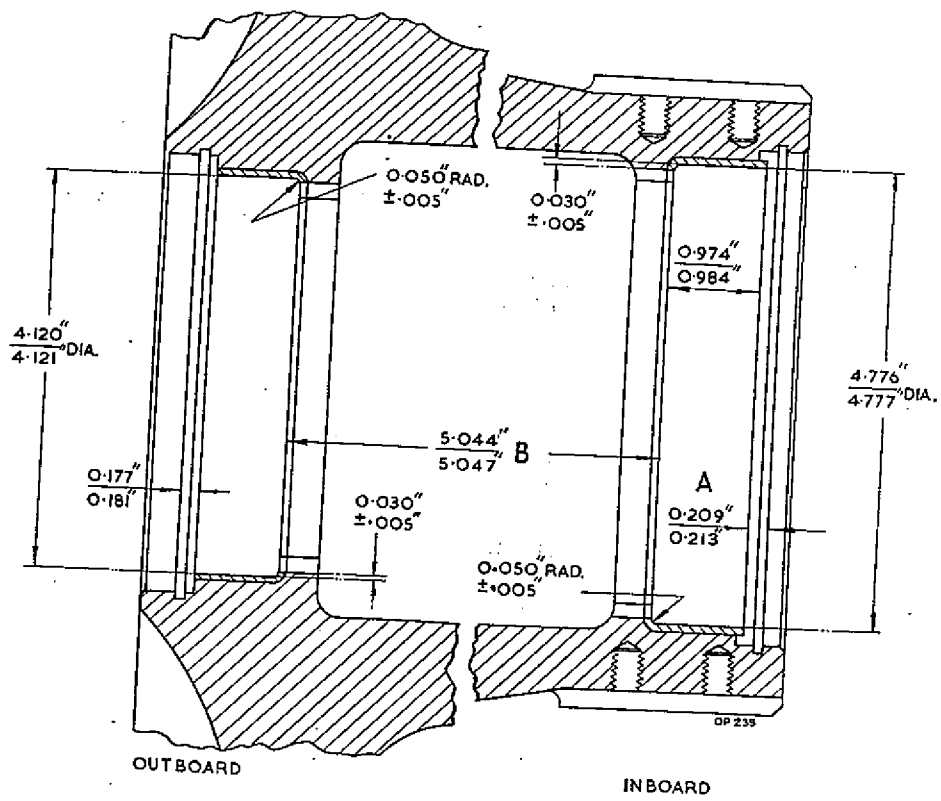

RP 11/6

Fig. 2. Dimensions for machining fitted liners

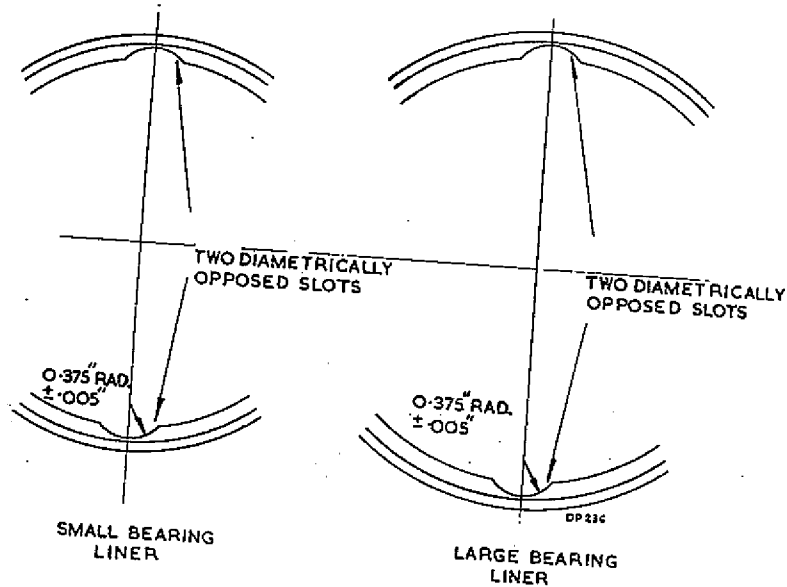

RP 11/8

Fig. 3. Machining the extractor slots

RESTRICTED

Method of repair

2. (1) Dismantle and degrease the wheel.
- (2) Mount the wheel casting in a lathe so that the chuck-jaws locate on the rim at the side on which the loose flange fits. It must then be set up so that the hub runs true in both the vertical and horizontal plane. To check for truth, apply a dial test indicator to the tapered surface of the nave near the inner end of the drive blocks; the maximum D.T.I. variation permitted is 0.002 in. It is essential that dimension "A" in RP11/5 (fig. 1) is obtained first to establish the datum face from which the subsequent machining may be carried out.
- (3) Machine the inboard or larger housing to the dimensions given in fig. 1. Check against drawing requirements.
- (4) Reverse the wheel in the lathe, adjust the chucks to grip the fixed flange, then set up as in (2). Apply the dial test indicator to the excluder bore; the maximum D.T.I. variation permitted is 0.002 in. Machine the outboard or smaller bearing housing to the dimensions given in fig. 1. Check against drawing requirements.
- (5) Clean the machined surfaces and repair the chromate film (*A.P.2656A, Vol. 1, Sect. 5, Chap. 2 refers*).
- (6) Apply a thin coating of pigmented varnish jointing compound (*Stores Ref. 33C/1264*) to the machined surfaces of each bearing housing.
- (7) Position the steel liners Part No. RP11/7A and RP11/7B in their respective housings and ensure that the face of each liner is square to the horizontal axis of the wheel.
- (8) Place the press tool Part No. RT/7 on the press bed, position the wheel on the press tool so that the spigot of the tool enters the larger liner and check that the liner has not been disturbed. Enter the spigot of the press tool, Part No. RT/8, in the smaller liner and operate the press, up to a maximum of 3 tons, to press the liners into their housings.

There must be no gap between the inner faces of the liners and the abutment faces of their housings; check this with an 0.0015 in. feeler gauge.

- (9) Position the wheel in the lathe and set up as in (2). Machine the inboard liner to all relevant dimensions, except "B", given in RP11/6 (fig. 2.) The dimension A must be obtained first to establish the datum face from which the subsequent machining may be carried out. The finished bore must be perfectly smooth and free from tool marks.
- (10) Reverse the wheel in the lathe, set up as in (4) and machine the other liner to all relative dimensions, including "B", given on RP11/6 (fig. 2) appropriate to the outboard liner. The finished bore must be perfectly smooth and free from tool marks.
- (11) Ascertain that all machined dimensions conform to drawing requirements.
- (12) Set the wheel casting up on the table of a vertical miller so that the cutter will ultimately engage the existing extractor slots. Using an 0.750 in. dia. end-mill, machine two slots as in RP11/8 (fig. 3) to conform with the extractor slots.
- (13) Reverse the wheel casting and repeat operation (12) at the other side of the hub.
- (14) Remove all burrs from the slots, and after cleaning, repair the chromate film (*A.P.2656A, Vol. 1, Sect. 5, Chap. 2 refers*). **2656A**

Inspection

3. The repair must be to the satisfaction of the supervising inspector A.I.D., C.I.O/N.A.I., or C.I.O/A.I.S.

Identification

4. After satisfactory completion of the repair use $\frac{1}{8}$ in. metal stamps to mark "RP11" below the assembly Issue No. on the spoke wall at the end of the hub. After marking the wheel, paint the indentations with selenious acid solution.

RESTRICTED

RP 12

REPAIR TO HOUSINGS FOR WHEEL BEARINGS

Requirements

Lathe:

Herbert No. 9B, combination or its equivalent. The surface cutting speed for turning operations must be approximately 200 ft. per min. for the Elektron hub and 50 ft. per min. for the steel liners.

Press:

Hydraulic or mechanical.

Press tools:

Bearing liner punches, Part No. AO.100785 and AO.100786 (Table 3). Mandrel and base assembly, Part No. AO.42853. Collars, Part No. AO.42807 and AO.101132.

New Parts:

Liner, Part No. RP.12/6A for bearing housing at fixed flange end, and liner, Part No. RP.12/6B for bearing housing at loose flange end. The liners (Table 1) to be provided under Unit arrangements.

Selenious acid solution:

2 oz. Selenious acid crystals dissolved in one pint of water.

WARNING

Selenious acid crystals or solution must not be allowed to come into contact with the skin.

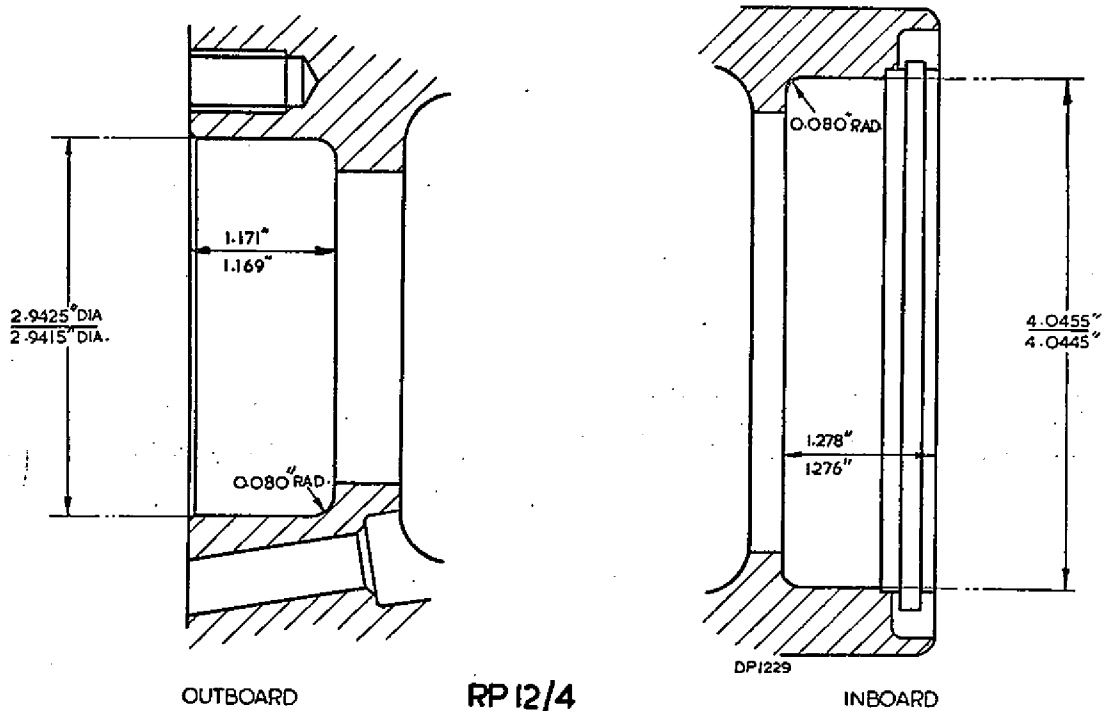

Fig. 1. Dimensions for machining housings

Introduction

1. Due to various causes, the housings for the wheel bearings may become so enlarged that the outer track of one or both bearings will creep. When this condition arises, the affected housing(s) must be enlarged and steel liner(s) fitted to restore the housing(s) to their original dimensions.

Method of repair

2. (1) Dismantle and degrease the wheel.
- (2) Remove the paint as described in A.P.2337, Vol. 1, Sect. 1, Chap. 1.
- (3) Mount the wheel casting in a lathe so that the chuck-jaws locate on the rim at the side on which the loose flange fits. It must then be set up so that the hub runs true in both the vertical and horizontal planes. To check for truth, apply a dial test indicator to the hub of the bearing housing; the maximum permitted D.T.I. variation is 0.002 in.
- (4) Machine the bearing housing at the fixed flange end of the wheel to the dimensions given in RP.12/4 (fig. 1).
- (5) Reverse the wheel in the lathe and adjust the chuck to grip the fixed flange, set up as described in (3) and machine the housing at the loose flange end of the wheel to the dimension given in RP.12/4 (fig. 1). Check against drawing dimensions.

- (6) Clean the machined surfaces and repair the chromate film (A.P.2656A, Vol. 1, Sect. 5, Chap. 2).
- (7) Heat the hub to a temperature of 100 deg. C. by immersing it in boiling water. While the hub retains its heat quickly dry it, and coat the contact faces of the liner housings with a thin coating of pigmented varnish jointing compound (Stores Ref. 33C/1264).
- (8) Position the mandrel, base, and collar on the press, and position the wheel, loose flange end upwards, over the mandrel.
- (9) Place the flanged end of the steel liner RP.12/6B in the mouth of the bearing housing at the loose flange end of the wheel and ensure that it is square to the horizontal axis of the hub. Position the press tool, AO.100785 in the liner, place the collar over the press tool and operate the press to house the liner. There must be no end gap between the seating face of the liner and the abutment face of the housing; check this using a 0.0015 in. feeler gauge. Reverse the wheel and repeat the operation at the other side using steel liner RP.12/6A and press tool AO.100786.

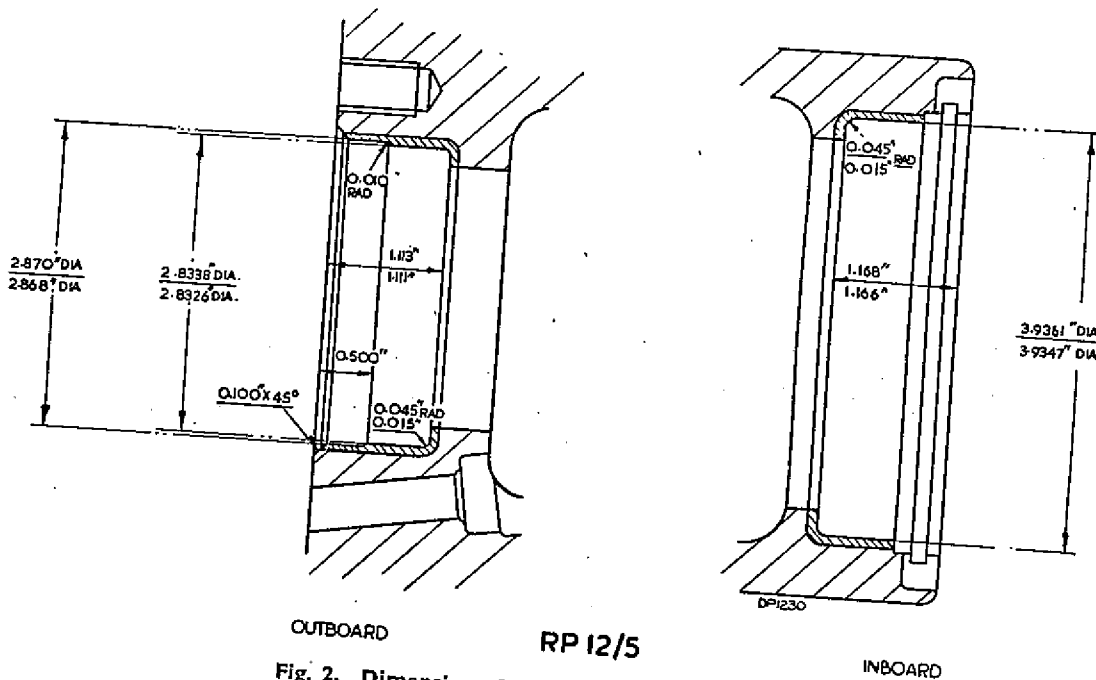

Fig. 2. Dimensions for machining fitted liners

RESTRICTED

(10) Position the wheel in the lathe and set up as in (3). Machine the liner at the fixed flange end to the dimensions given in RP.12/5. Face the end of the liner flush with the hub. The finished bore must be smooth and free from tool marks. Check against drawing dimensions.

(11) Reverse the wheel in the lathe and set up as in (5). Machine the liner at the loose flange end to all relative dimensions given in RP.12/5. The bore must be smooth and free from tool marks. Check against drawing dimensions.

Inspection

3. The repair must be to the satisfaction of the supervising inspector A.I.D., C.I.O./N.A.I. or C.I.O./A.I.S.

Painting

4. Repaint the hub as described in A.P.2337, Vol. 1, Sect. 1, Chap. 1.

Identification

5. After satisfactory completion of the repair use $\frac{1}{8}$ in. metal stamps to mark "RP.12" below the assembly issue number on the wheel. After marking the wheel, paint the indentations with selenious acid solution.

RP 13

REPAIR TO HOUSING FOR WHEEL BEARINGS

Equipment required

Lathes: Herbert No. 9B or its equivalent.

The speed for all turning operations to be approximately 100 r.p.m.

Press: Hydraulic or mechanical; press loading $3\frac{1}{2}$ tons maximum.

Press tools: Two bearing liner punches Part No. RT.2 (refer to Table 2).

Selenious acid solution: 2 oz. selenious acid crystals dissolved in one pint of water.

New Parts: Two liners, Part No. RP.13/6 (see Table 1) to be provided under unit arrangements.

WARNING

Selenious acid, crystals or solution, must not be allowed to come in contact with the skin.

Introduction

1. Due to various causes, the housings for the wheel bearings may become enlarged, resulting in creep of the bearing outer tracks. When this condition arises, both bearing housings are to be enlarged and steel liners fitted to restore the housings to their original dimensions.

Method of repair

2. (1) Dismantle and degrease the wheel.
- (2) Mount the wheel casting in a lathe so that the chuck-jaws locate externally around the fixed flange end of the wheel. The hub must then be set up to run perfectly true in both the vertical and horizontal plane. To check for truth apply a dial test indicator to the excluder housing; the maximum D.T.I. variation permitted is 0.002 in.
- (3) Machine the outboard (shallower housing) to the dimensions given in RP13/4 (fig. 1). Check against drawing requirements.
- (4) Reverse the wheel in the lathe and adjust the chucks to locate around the rim at the loose flange end of the wheel and set up as in (2). Apply the dial test indicator to the tapered nave of the wheel; the maximum D.T.I. variation permitted is 0.002 in.
- (5) Machine the inboard (deeper housing) to the dimensions given in RP13/4

(fig. 1). Check against drawing requirements.

- (6) Degrease the freshly machined surfaces and repair the chromate film (A.P.2656A, Vol. 1, Sect. 5, Chap. 2, refers).
- (7) Apply a thin coating of pigmented varnish jointing compound (Stores Ref. 33C/1264) to the machined surfaces of each housing.
- (8) Position the steel liners in their respective housings and ensure that the face of each liner is square to the horizontal axis of the wheel.
- (9) Place the press tool, Part No. RT.2 on the press bed, position the wheel on the press tool so that the spigot of the tool enters the lower liner and check that the liner has not been disturbed. Enter the spigot of the second press tool RT.2 in the upper liner and operate the press, up to a maximum of $3\frac{1}{2}$ tons, to press the liners into their housings. There must be no gap between the underside of the liners and the abutment faces of their housings; check this with a 0.0015 in. feeler gauge.
- (10) Position the wheel in the lathe and set up as in (4). Machine the inboard liner to all relevant dimensions (except B) given in RP13/5 (fig. 2). Machine to dimension A first to obtain the datum face from which the subsequent machining may be carried out. The finished bore must be perfectly smooth and free from tool marks.
- (11) Ascertain that all dimensions conform to drawing requirements.
- (12) Reverse the wheel in the lathe, set up as in (2) and machine the other liner to all relative dimensions, including B, given on RP13/5 (fig. 2) appropriate to the outboard liner. The finished bore must be perfectly smooth and free from tool marks.
- (13) Ascertain that all dimensions conform to drawing requirements.

Inspection

3. The repair must be to the satisfaction of the supervising inspector A.I.D., C.I.O./N.A.I., or C.I.O./A.I.S.

RESTRICTED

Identification

4. After satisfactory completion of the repair use $\frac{1}{8}$ in. metallic stamps to mark "RP13" immediately below the Issue No. on

the loose flange end of the wheel. After marking the wheel, the indentations must be brushed with selenious acid solution.

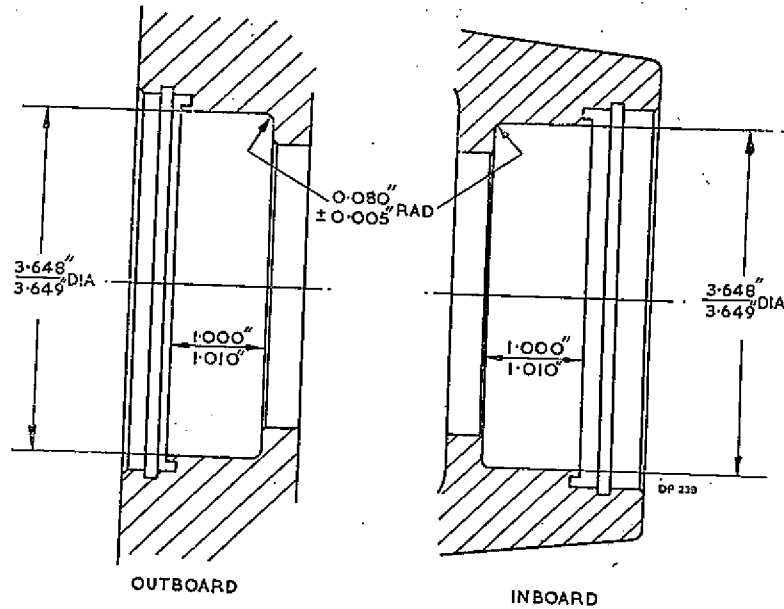

RP13/4

Fig. 1. Dimensions for machining the bearing housings

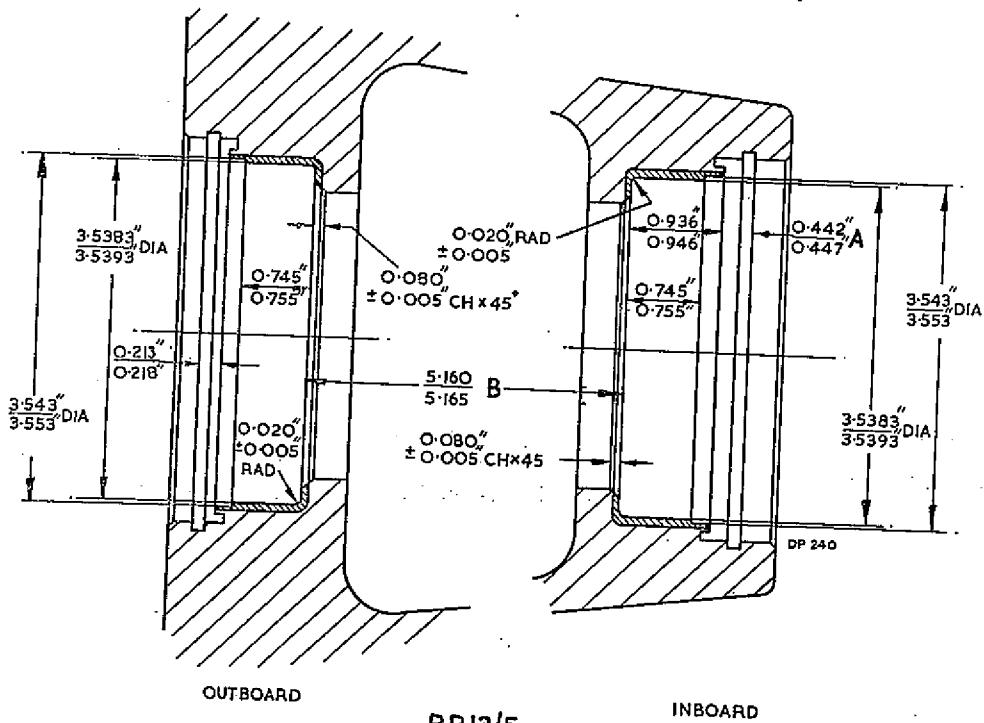

RP13/5

Fig. 2. Dimensions for machining fitted liners

RESTRICTED

el. After
ons must
tion.

This leaf issued with A.L. No. 13, June, 1953

A.P.2337, Vol. 6, Sect. 1, Chap. 1

RP 14

REPAIR TO HOUSING FOR WHEEL BEARINGS

Equipment required

Lathe: Herbert No. 9B or its equivalent. The speed for all turning operations to be approximately 100 r.p.m.

Press: Hydraulic or mechanical; press loading $6\frac{1}{2}$ tons maximum.

Press tools: Two bearing liner punches, Part No. RT9 (Table 2).

Selenious acid solution: 2 oz. selenious acid crystals dissolved in one pint of water.

New Parts.

Two liners, Part No. RP14/6, for the bearing housings. The liners (Table 1) to be provided under unit arrangements.

WARNING

Selenious acid, crystals or solution, must not be allowed to come into contact with the skin.

Description

1. Due to various causes, the housings for the wheel bearings often become enlarged to such an extent that the outer track of one or both bearings creep. When this condition arises, both bearing housings are to be enlarged and steel liners fitted to restore the housings to their original dimensions.

Method of repair

- (1) Dismantle and degrease the wheel.
- (2) Mount the wheel casting in a lathe so that the chuck-jaws locate on the rim on which the loose flange fits. It must then be set up so that the hub runs true in both the vertical and the horizontal plane. To check for truth apply a dial test indicator to the hub of the bearing housing; the maximum D.T.I. variation permitted is 0.002 in.

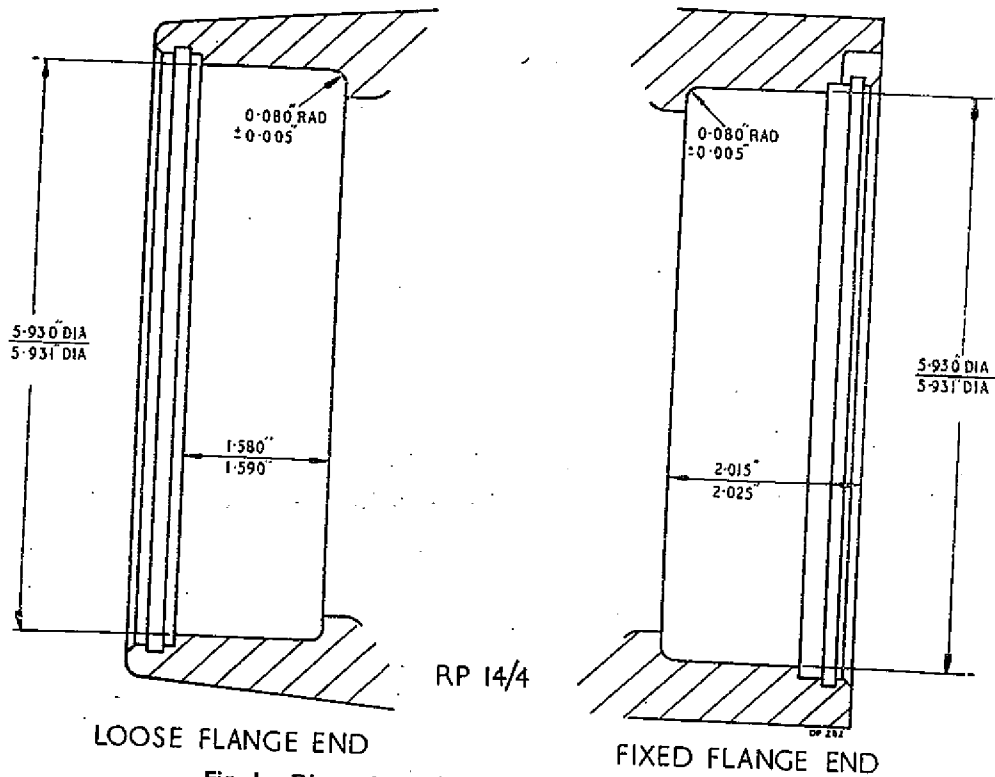

Fig. 1. Dimensions for machining bearing housings

RESTRICTED

- (3) Machine the bearing housing at the fixed flange end of the wheel to the dimensions given in RP14/4 (fig. 1). Check against drawing requirements.
- (4) Reverse the wheel in the lathe and adjust the chucks to grip the fixed flange, set up as in (2) and machine the housing at the loose flange end of the wheel to the dimensions given in RP14/4 (fig. 1). Check against drawing requirements.
- (5) Clean the machined surfaces and repair the chromate film (A.P.2656A, Vol. I, Sect. 5, Chap. 2, refers).
- (6) Apply a thin coating of pigmented varnish jointing compound (Stores Ref. 33C/1264) to the machined surfaces of each bearing housing.
- (7) Position the steel liners in their respective housings and ensure that the face of each liner is square to the horizontal axis of the wheel.
- (8) Place the press tool Part No. RT/9 on the press-bed, position the wheel on the press tool so that the spigot of the tool enters the lower liner and check that the liner has not been disturbed. Enter the spigot of the second press tool RT/9 in the upper liner and operate the press, up to a maximum of $6\frac{1}{2}$ tons, to press the liners into their housings. There must be no gap between the inner faces of the liners and the abutment faces of their housings; check this with an 0.0015 in. feeler gauge.
- (9) Set the wheel up in a lathe as in (4). Machine the liner at the loose flange end of the wheel to all relevant dimensions, except "B", given in RP14/5 (fig. 2). Machine to dimension "A" first to establish the datum face from which the subsequent machining may be carried out. The finished bore must be smooth and free from tool marks.
- (10) Reverse the wheel in the lathe and set up as in (2) and machine the other liner to all relative dimensions, including "B", given on RP14/5 (fig. 2). The bore must be smooth and free from tool marks.

Inspection

3. The repair must be to the satisfaction of the supervising inspector A.I.D., C.I.O./N.A.I., or C.I.O./A.I.S.

Identification

4. After satisfactory completion of the repair use $\frac{1}{8}$ in. metal stamps to mark "RP14" below the assembly issue number on the wheel. After marking the wheel, paint the indentations with selenious acid solution.

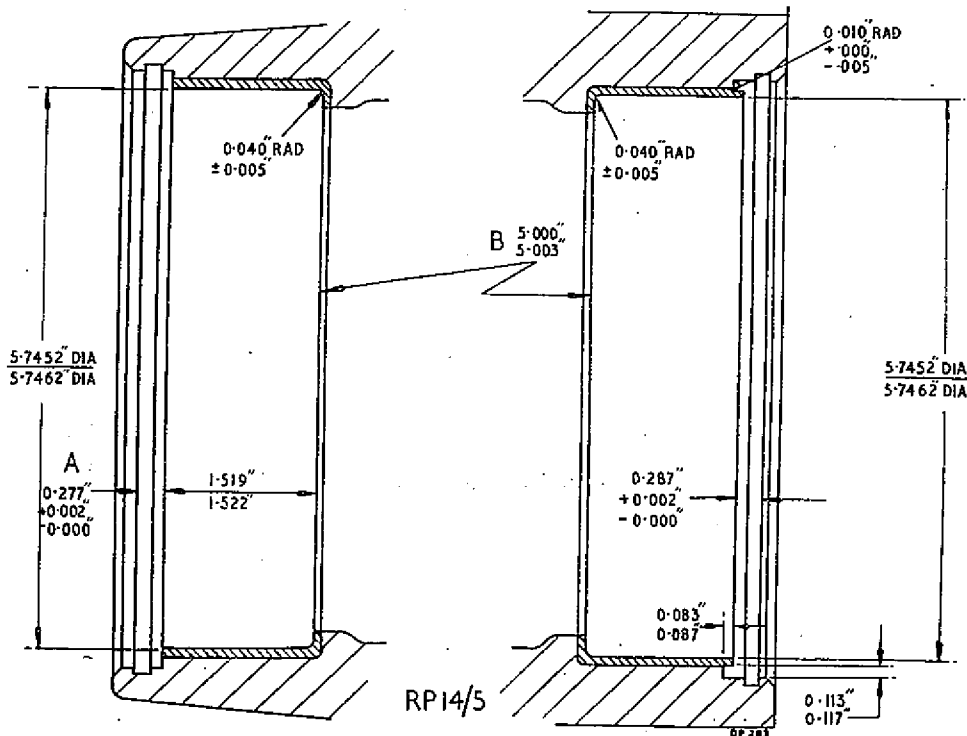

Fig. 2. Dimensions for machining fitted liners

RESTRICTED

RP26

REPAIR TO HOUSING FOR WHEEL BEARINGS

Equipment required

Lathe: Herbert No. 9B or its equivalent. The speed for all turning operations to be approximately 100 r.p.m.

Press: Hydraulic or mechanical; press loading, liner at fixed flange end $3\frac{1}{2}$ tons maximum; liner at loose flange end 4 tons maximum.

Press tools: Bearing liner punches, Part No. RT/2 and RT/23 (Table 2).

Vertical milling machine: Cincinnati No. 2 or its equivalent. The operating speed for milling operations should be 500 to 1,500 r.p.m.

Selenious acid solution: 2 oz. selenious acid crystals dissolved in one pint of water.

New Parts: Liner, Part No. RP26/7A for bearing liner at fixed flange end and liner, Part No. RP26/7B for bearing housing at loose flange end. The liners (Table 1) to be provided under Unit arrangements.

WARNING

Selenious acid crystals or solution must not be allowed to come into contact with the skin.

Introduction

1. Due to various causes the housings for the wheel bearings may become enlarged to such an extent that the outer track of one or both bearings creeps. When this condition arises the affected housing or housings must be enlarged and steel liner(s) fitted to restore the housing(s) to the original dimensions. Para. 2 details the full procedure for repairing both housings; where only one housing is worn the appropriate sub-para. only, will apply.

Method of Repair

2.

- (1) Dismantle and degrease the wheel.
- (2) Remove the paint as described in Vol. 1, Sect. 1, Chap. 1, para. 53.

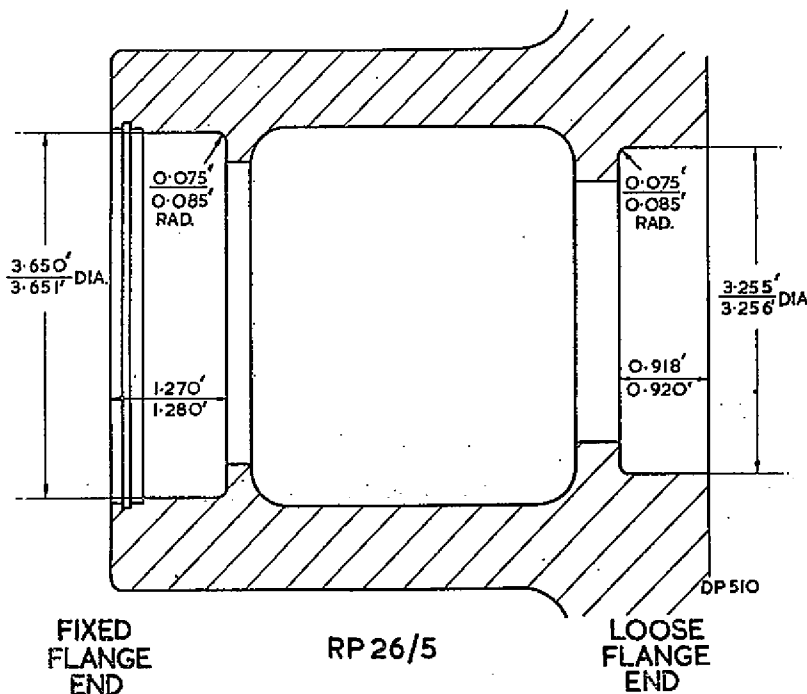

Fig. 1. Dimensions for machining bearing housing

RESTRICTED

- (3) Mount the wheel casting in a lathe so that the chuck-jaws locate on the rim at the side on which the loose flange fits. It must then be set up so that the hub runs true in both the vertical and the horizontal planes. To check for truth apply a dial test indicator to the hub of the bearing housing; the maximum permitted D.T.I. variation is 0.002 in.
- (4) Machine the bearing housing at the fixed flange end of the wheel to the dimensions given in RP26/5 (fig. 1). Check against drawing requirements.
- (5) Reverse the wheel in the lathe and adjust the chucks to grip the fixed flange, set up as described in (3) and machine the housing at the loose flange end of the wheel to the dimensions given in RP26/5 (fig. 1). Check against drawing requirements.
- (6) Clean the machined surfaces and repair the chromate film (*A.P.2656A, Vol. 1, Sect. 5, Chap. 2, refers*).
- (7) Apply a thin coating of pigmented varnish jointing compound (*Stores Ref. 33C/1264*) to the machined surfaces of each bearing housing.
- (8) Position the flanged end of the steel liner RP26/7A in the mouth of the bearing housing at the fixed flange end and ensure that it is perfectly square to the horizontal axis of the hub.
- (9) Support the wheel and keep the rim clear of the press-bed by placing a parallel block between the bed of the press and the adjacent wheel nave. The block must be in full contact with the centre boss of the wheel and in no circumstances must it touch the outer flange. Failure to comply with this instruction may result in strain to the hub casting. Position a press tool RT/2 in the liner and operate the press up to a max. of 3½ tons to press the liner home in the housing. There must be no end gap between the end of the liner and the abutment face of the housing; check this with a 0.0015 in. feeler gauge. Reverse the wheel and repeat the operation at the other side using steel liner RP26/7B, press tool RT/23 and a press loading of up to 4 tons.
- (10) Position the wheel in the lathe and set up as in (5). Machine the liner at the loose flange end to dimension "A" first and then to all other dimensions appropriate to the liner, except "B", given in RP26/6 (fig. 2). The finished bore must be smooth and free from tool marks. Check against drawing requirements.
- (11) Reverse the wheel in the lathe and set up as in (3). Machine the liner at the

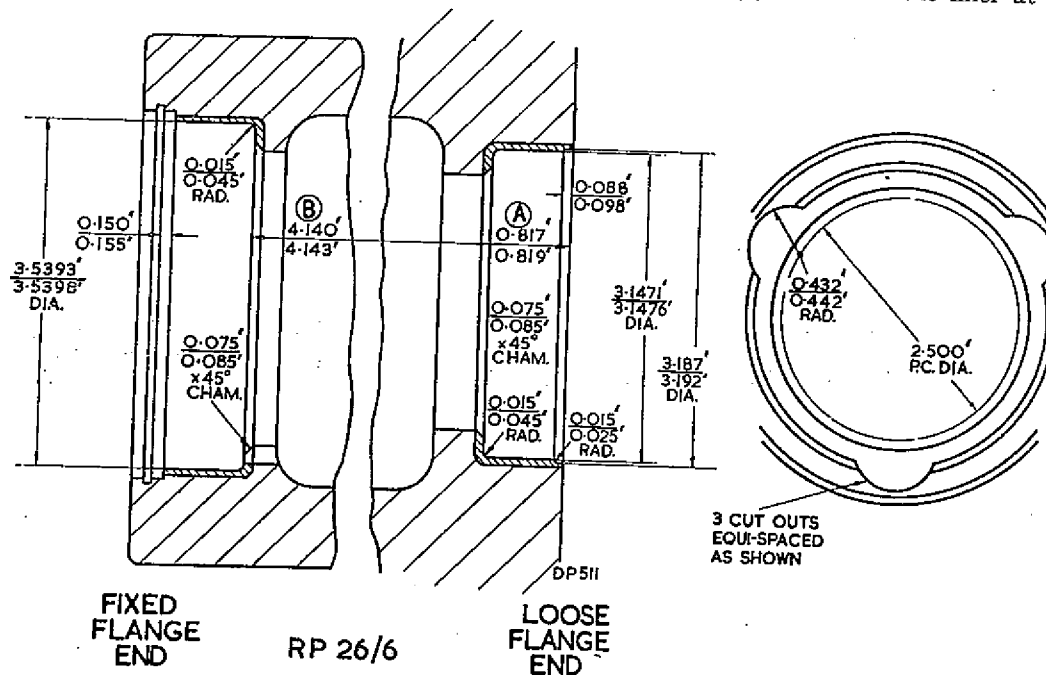

Fig. 2. Dimensions for machining fitted liners

RESTRICTED

fixed flange end to all relative dimension, including "B", given in RP26/6 (fig. 2). The bore must be smooth and free from tool marks. Check against drawing requirements.

- (12) Set the wheel up on the table of a vertical miller and position it so that the cutting tool will ultimately re-engage the existing extractor slots in the hub at the fixed flange end of the wheel. Using a $\frac{7}{8}$ in. dia. end mill, mill three slots as shown in RP26/6 (fig. 2) to conform with the existing extractor slots. Carefully remove all burrs and check that the slots conform to drawing requirements.

Inspection

3. The repair must be to the satisfaction of the supervising inspector A.I.D., C.I.O./N.A.I., or C.I.O./A.I.S.

Painting

4. Repaint the hub as described in Vol. 1, Sect. 1, Chap. 1, para. 54.

Identification

5. After satisfactory completion of the repair use $\frac{1}{8}$ in. metal stamps to mark "RP26" below the assembly Issue No. on the wheel. After marking the wheel, paint the indentations with selenious acid solution.

RESTRICTED

RP27

REPAIR TO HOUSING FOR WHEEL BEARINGS

Requirements

Lathe: Herbert No. 9B or its equivalent. The speed for all turning operations to be approximately 100 r.p.m.

Press: Hydraulic or mechanical; press loading on liners 1.8 tons max.

Press tools: Bearing liner punch, Part No. RT/19 (Table 2)

Selenious acid solution: 2 oz. Selenious acid crystals dissolved in one pint of water.

New parts: Liners, Part No. RP27/6 for inboard and outboard bearing housings. The liners (Table 1) to be provided under Unit arrangements.

WARNING

Selenious acid crystals or solution must not be allowed to come into contact with the skin.

Introduction

1. Due to various causes the housings for the wheel bearings may become enlarged to such an extent that the outer track of one or both bearings creep. When this condition arises both bearing housings are to be enlarged, and steel liners fitted to restore the housings to their original dimensions.

Method of repair

2. (1) Dismantle and degrease the wheel.
- (2) Mount the wheel casting in a lathe so that the chuck-jaws locate on the rim at the inboard or brake side of the wheel. It must then be set up so that the hub runs true in both the vertical and the horizontal planes. To check for truth apply a dial test indicator to the hub of the bearing housing; the maximum permitted D.T.I. variation is 0.002 in.
- (3) Machine the outboard bearing housing to the dimensions given in RP27/4 (fig. 1). Check against drawing requirements.
- (4) Reverse the wheel in the lathe and adjust the chucks to grip the rim at the outboard side, set up as described in (2) and machine the inboard housing at the brake side of the wheel to the dimensions given in RP27/4 (fig. 1). Check against drawing requirements.

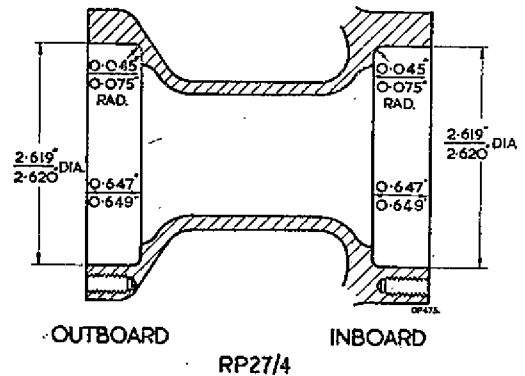
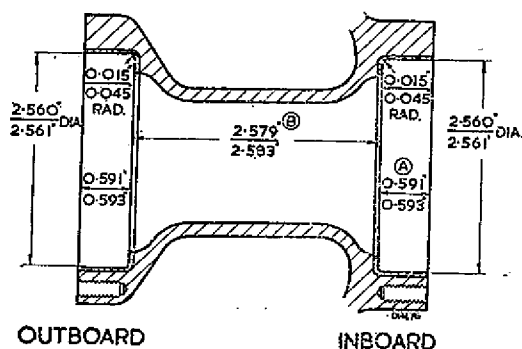

Fig. 1. Dimensions for machining bearing housings

- (5) Clean the machined surfaces and repair the chromate film (A.P.2656A, Vol. 1, Sect. 5, Chap. 2, refers).
- (6) Apply a thin coating of pigmented varnish jointing compound (Stores Ref. 33C/1264) to the machined surfaces of each bearing housing.
- (7) Position the flanged end of the steel liner, RP27/6, in the mouth of the inboard bearing housing and ensure that it is perfectly square to the horizontal axis of the hub.
- (8) Support the wheel and keep the rim clear of the press bed by placing a parallel block between the bed of the press and the adjacent wheel nave. The block must be in full contact with the centre boss of the wheel and in no circumstances must it touch the outer flange. Failure to comply with this instruction may result in strain to the hub castings. Position a press tool RT/19 in the liner and operate the press up to a max. of 1.8 tons to press the liner home in the housing. There must be no end gap between the inner end of the liner and the abutment face of the housing; check this with a 0.0015 in. feeler gauge. Reverse the wheel and repeat the operation at the other side of the wheel using steel liner RP27/6 and a press loading of up to 1.8 tons.

RESTRICTED



OUTBOARD

INBOARD

RP27/5

Fig. 2. Dimensions for machining fitted liners

- (9) Position the wheel in the lathe and set up as in (4). Machine the inboard liner to dimension "A" first and then to all other dimensions appropriate to the liner, except "B", given in RP27/5 (fig. 2). The bore must be smooth and

free from tool marks. Check against drawing requirements.

- (10) Reverse the wheel in the lathe and set up as in (2). Machine the outboard liner to all relative dimensions, including "B", given in RP27/5 (fig. 2). The bore must be perfectly smooth and free from tool marks. Check against drawing requirements.

Inspection

3. The repair must be to the satisfaction of the supervising inspector A.I.D., C.I.O./N.A.I., or C.I.O./A.I.S.

Identification

4. After the satisfactory completion of the repair use $\frac{1}{8}$ in. metal stamps to mark "RP27" below the assembly Issue Number on the wheel. After marking the wheel paint the indentations with Selenious acid solution.

RESTRICTED

RP 28

REPAIR TO HOUSING FOR WHEEL BEARINGS

Requirements

Lathe: Herbert No. 9B or its equivalent. The speed for all turning operations to be approximately 100 r.p.m.

Press: Hydraulic or mechanical; press loading on liner at fixed flange end $3\frac{1}{2}$ tons max., and on liner at loose flange end $5\frac{1}{2}$ tons max.

Press tools: Bearing liner punches, Part Nos. RT/20 and RT/21 (Table 2).

Selenious acid solution: 2 oz. Selenious acid crystals dissolved in one pint of water.

New parts: Liner, Part No. RP28/6A for bearing housing at fixed flange end, and liner, Part No. RP28/6B for bearing housing at loose flange end. The liners (Table 1) to be provided under Unit arrangements.

WARNING

Selenious acid crystals or solution must not be allowed to come into contact with the skin.

Introduction

1. Due to various causes the housings for the wheel bearings may become enlarged to such an extent that the outer track of one or both bearings creep. When this condition

arises both bearing housings are to be enlarged, and steel liners are to be fitted to restore the housings to their original dimensions.

Method of repair

2. (1) Dismantle and degrease the wheel.
- (2) Mount the wheel casting in a lathe so that the chuck-jaws locate on the rim at the side on which the loose flange fits. It must then be set up so that the hub runs true in both the vertical and the horizontal planes. To check for truth apply a dial test indicator to the hub of the bearing housing; the maximum permitted D.T.I. variation is 0.002 in.
- (3) Machine the bearing housing at the fixed flange end of the wheel to the dimensions given in RP28/4 (fig. 1). Check against drawing requirements.
- (4) Reverse the wheel in the lathe and adjust the chucks to grip the fixed flange, set up as described in (2) and machine the housing at the loose flange end of the wheel to the dimensions given in RP28/4 (fig. 1). Check against drawing requirements.

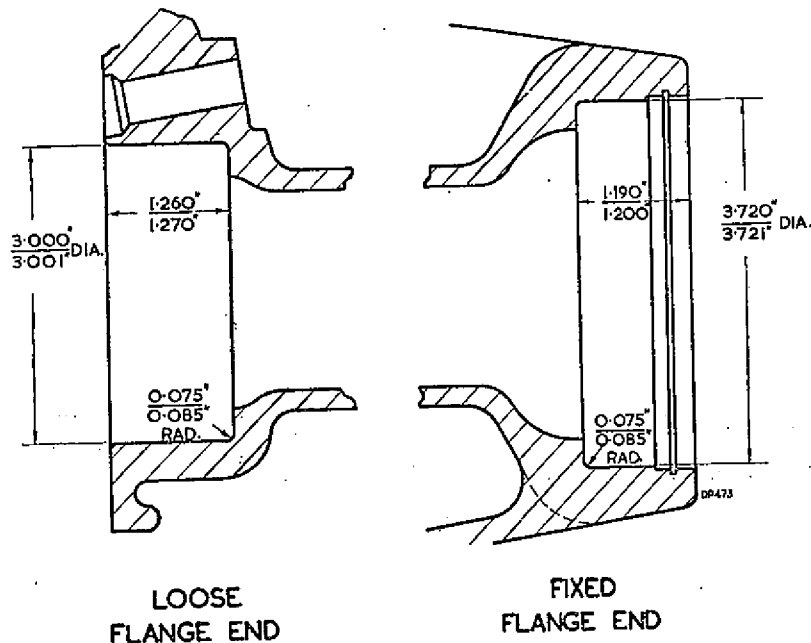

RP28/4

Fig. 1. Dimensions for machining bearing housings

RESTRICTED

- (5) Clean the machined surfaces and repair the chromate film (*A.P.2656A, Vol. 1, Sect. 5, Chap. 2, refers*).
- (6) Apply a thin coating of pigmented varnish jointing compound (*Stores Ref. 33C/1264*) to the machined surfaces of each bearing housing.
- (7) Position the flanged end of the steel liner RP28/6A in the mouth of the bearing housing at the fixed flanged end and ensure that it is perfectly square to the horizontal axis of the hub.
- (8) Support the wheel and keep the rim clear of the press bed by placing a parallel block between the bed of the press and the adjacent wheel nave. The block must be in full contact with the centre boss of the wheel and in no circumstances must it touch the outer flange. Failure to comply with this instruction may result in strain to the hub casting. Position a press tool RT/20 in the liner and operate the press up to a max. of $3\frac{1}{2}$ tons to press the liner home in the housing. There must be no end gap between the inner end of the liner and the abutment face of the housing; check this with a 0.0015 in. feeler gauge. Reverse the wheel and repeat the operation at the

other side of the wheel using steel liner RP28/6B, press tool RT/21 and a press loading of up to $5\frac{1}{2}$ tons.

- (9) Position the wheel in the lathe and set up as in (4). Machine the liner at the loose flange end to dimension "A" first and then to all other dimensions appropriate to the liner, except "B", given in RP28/5 (*fig. 2*). The bore must be smooth and free from tool marks. Check against drawing requirements.
- (10) Reverse the wheel in the lathe and set up as in (2). Machine the liner at the fixed flange end to all relative dimensions, including "B" given in RP28/5. The bore must be perfectly smooth and free from tool marks. Check against drawing requirements.

Inspection

3. The repair must be to the satisfaction of the supervising inspector A.I.D., C.I.O./N.A.I., or C.I.O./A.I.S.

Identification

4. After the satisfactory completion of the repair use $\frac{1}{8}$ in. metal stamps to make "RP28" below the assembly Issue No. on the wheel. After marking the wheel, paint the indentations with selenious acid solution.

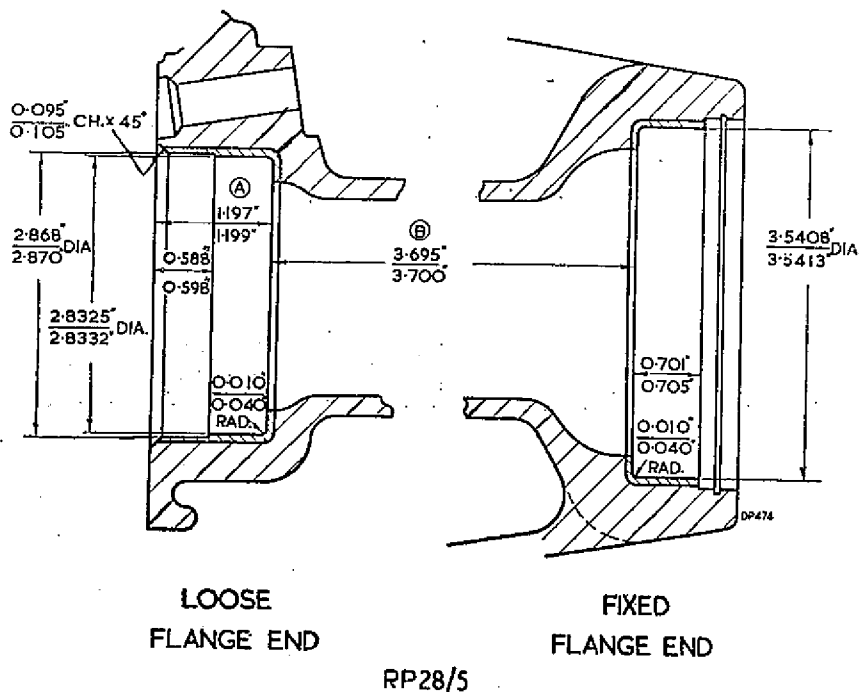

Fig. 2. Dimensions for machining fitted liners

RESTRICTED

RP 37

REPAIR TO HOUSING FOR WHEEL BEARINGS

Equipment required

Lathe: Herbert No. 9B or its equivalent.

The speed for all turning operations to be approximately 100 r.p.m.

Press: Hydraulic or mechanical: press loading on liners $1\frac{1}{2}$ tons maximum.

Press tool: Bearing liner punch, Part No. RT/27 (Table 2).

Selenious acid solution: 2 oz. selenious acid crystals dissolved in one pint of water.

New parts: Two liners, Part No. RP37/6, for bearing housings. The liners (Table 1) to be provided under Unit arrangements.

WARNING

Selenious acid crystals or solution must not be allowed to come into contact with the skin.

Introduction

1. Due to various causes the housings for the wheel bearings may become enlarged to such an extent that the outer track of one or both bearings creeps. When this condition arises the affected housing(s) must be enlarged and steel liner(s) fitted to restore the housing(s) to the original dimensions. Para. 2 details the procedure to be followed when both housings are affected; where only one housing is worn the appropriate sub-para. only will apply.

Method of repair

2. (1) Dismantle and degrease the wheel.
- (2) Remove the old paint as described in Vol. 1, Sect. 1, Chap. 1, para. 53.
- (3) Mount the wheel casting in a lathe so that the chuck-jaws locate on the rim at the fixed flange end. Then set it up so that the hub runs true in both the vertical and the horizontal planes. To check for truth apply a dial test indicator to the tyre seat; the maximum permitted D.T.I. variation is 0.002 in.
- (4) Machine the bearing housing at the loose flange end of the wheel to the dimensions given in RP37/4 (fig. 1). Check against drawing requirements.

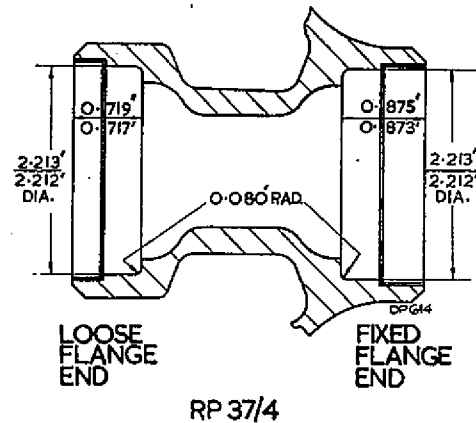

Fig. 1. Dimensions for machining bearing housings

- (5) Reverse the wheel in the lathe and adjust the chucks to locate on the rim at the side on which the loose flange fits, set up as described in (3) and machine the housing at the fixed flange end of the wheel to the dimensions given in RP37/4 (fig. 1). Check against drawing requirements.
- (6) Clean the machined surfaces and repair the chromate film (A.P.2656A, Vol. 1, Sect. 5, Chap. 2, refers).
- (7) Apply a thin coating of pigmented varnish jointing compound (Stores Ref. 33C/1264) to the machined surfaces of each bearing housing.
- (8) Position the flanged end of the steel liner RP37/6 in the mouth of the bearing housing at the fixed flange end and ensure that it is perfectly square to the horizontal axis of the hub.
- (9) Support the wheel and keep the rim clear of the press bed by placing a parallel block between the bed of the press and the adjacent wheel nave. The block must be in full contact with the centre boss of the wheel and in no circumstances must it touch the outer flange. Failure to comply with this instruction may result in strain to the hub casting. Position a press tool

(A.L.20, May 54)

RESTRICTED

RP 37

REPAIR TO HOUSING FOR WHEEL BEARINGS

Equipment required

Lathe: Herbert No. 9B or its equivalent.

The speed for all turning operations to be approximately 100 r.p.m.

Press: Hydraulic or mechanical: press loading on liners $1\frac{1}{2}$ tons maximum.

Press tool: Bearing liner punch, Part No. RT/27 (*Table 2*).

Selenious acid solution: 2 oz. selenious acid crystals dissolved in one pint of water.

New parts: Two liners, Part No. RP37/6, for bearing housings. The liners (*Table 1*) to be provided under Unit arrangements.

WARNING

Selenious acid crystals or solution must not be allowed to come into contact with the skin.

Introduction

1. Due to various causes the housings for the wheel bearings may become enlarged to such an extent that the outer track of one or both bearings creeps. When this condition arises the affected housing(s) must be enlarged and steel liner(s) fitted to restore the housing(s) to the original dimensions. Para. 2 details the procedure to be followed when both housings are affected; where only one housing is worn the appropriate sub-para. only will apply.

Method of repair

2. (1) Dismantle and degrease the wheel.
- (2) Remove the old paint as described in Vol. 1, Sect. 1, Chap. 1, para. 53.
- (3) Mount the wheel casting in a lathe so that the chuck-jaws locate on the rim at the fixed flange end. Then set it up so that the hub runs true in both the vertical and the horizontal planes. To check for truth apply a dial test indicator to the tyre seat; the maximum permitted D.T.I. variation is 0.002 in.
- (4) Machine the bearing housing at the loose flange end of the wheel to the dimensions given in RP37/4 (*fig. 1*). Check against drawing requirements.

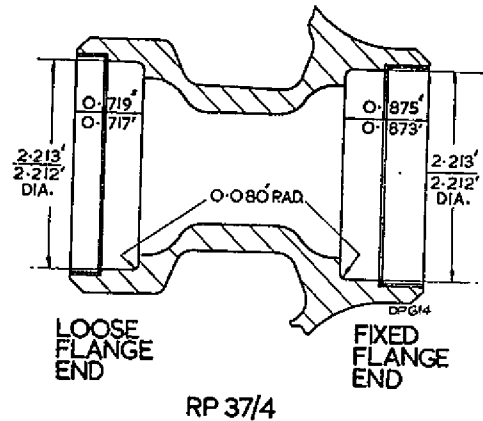

Fig. 1. Dimensions for machining bearing housings

- (5) Reverse the wheel in the lathe and adjust the chucks to locate on the rim at the side on which the loose flange fits, set up as described in (3) and machine the housing at the fixed flange end of the wheel to the dimensions given in RP37/4 (*fig. 1*). Check against drawing requirements.
- (6) Clean the machined surfaces and repair the chromate film (*A.P.2656A, Vol. 1, Sect. 5, Chap. 2, refers*).
- (7) Apply a thin coating of pigmented varnish jointing compound (*Stores Ref. 33C/1264*) to the machined surfaces of each bearing housing.
- (8) Position the flanged end of the steel liner RP37/6 in the mouth of the bearing housing at the fixed flange end and ensure that it is perfectly square to the horizontal axis of the hub.
- (9) Support the wheel and keep the rim clear of the press bed by placing a parallel block between the bed of the press and the adjacent wheel nave. The block must be in full contact with the centre boss of the wheel and in no circumstances must it touch the outer flange. Failure to comply with this instruction may result in strain to the hub casting. Position a press tool

RESTRICTED

(A.L.20, May 54)

RP 38

REPAIR TO HOUSINGS FOR WHEEL BEARINGS

Equipment required

Lathe: Herbert No. 9B or its equivalent.
The speed for all turning operations to be approximately 100 r.p.m.

Press: Hydraulic or mechanical; press loading on liner at fixed flange end $1\frac{1}{2}$ tons maximum and on liner at loose flange end $2\frac{1}{2}$ tons maximum.

Press tool: Bearing liner punch, Part No. RT28 (Table 2).

Selenious acid solution: 2 oz. selenious acid crystals dissolved in one pint of water.

New parts: Liner, Part No. RP38/6A for bearing housing at fixed flange end, and liner, Part No. RP38/6B for bearing housing at loose flange end. The liners (Table 1) to be provided under unit arrangements.

WARNING

Selenious acid crystals or solution must not be allowed to come into contact with the skin.

Introduction

1. Due to various causes the housings for the wheel bearings may become enlarged to such an extent that the outer track of one or both bearings creeps. When this condition arises the affected housing(s) must be

enlarged and steel liner(s) fitted to restore the housing(s) to the original dimensions. Para. 2 details the procedure to be followed when both housings are affected; where only one housing is worn the appropriate sub-para. only will apply.

Method of repair

2. (1) Dismantle and degrease the wheel.
- (2) Remove the paint as described in Vol. 1, Sect. 1, Chap. 1, para. 53.
- (3) Mount the wheel casting in a lathe so that the chuck-jaws locate on the rim at the side on which the loose flange fits. It must then be set up so that the hub runs true in both the vertical and the horizontal planes. To check for truth apply a dial test indicator to the hub of the bearing housing; the maximum permitted D.T.I. variation is 0.002 in.
- (4) Machine the bearing housing at the fixed flange end of the wheel to the dimensions given in RP38/4 (fig. 1).
- (5) Reverse the wheel in the lathe and adjust the chucks to grip the fixed flange, set up as described in (3) and machine the housing at the loose flange end of the wheel to the dimensions

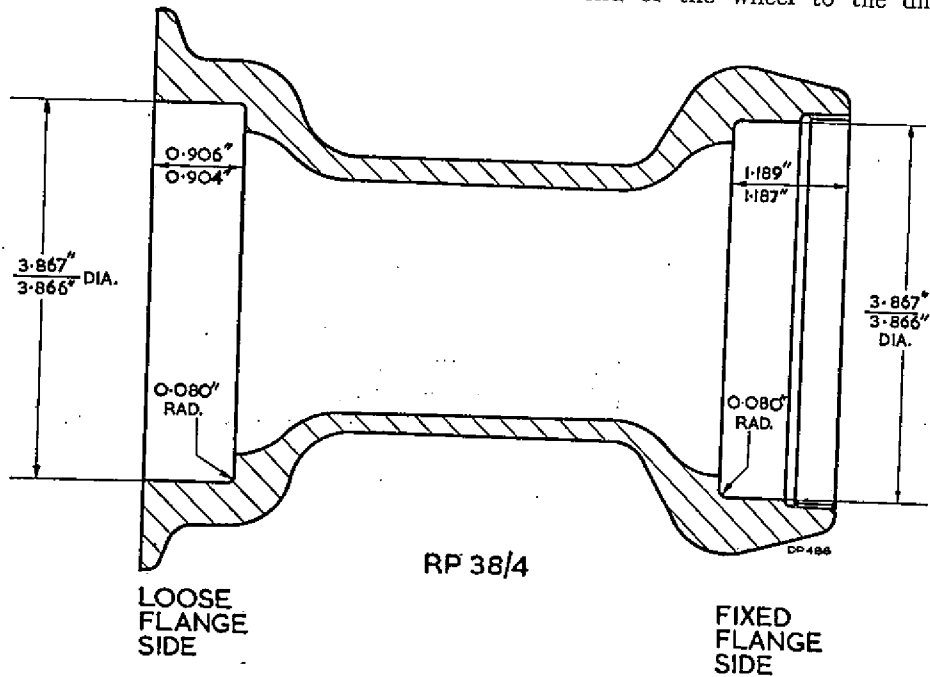

Fig. 1. Dimensions for machining bearing housings

RESTRICTED

(A.L.19, Mar. 54)

of the
ark "RP
on the
unt the
olution.

$\frac{2.124}{2.123}$
DIA.

3RS

given in RP38/4 (fig. 1). Check against drawing dimensions.

- (6) Clean the machined surfaces and repair the chromate film (*A.P.2656A, Vol. 1, Sect. 5, Chap. 2 refers*).
- (7) Apply a thin coating of pigmented varnish jointing compound (*Stores Ref. 33C/1264*) to the machined surfaces of each bearing housing.
- (8) Position the flanged end of the steel liner RP38/6A in the mouth of the bearing housing at the fixed flange end and ensure that it is perfectly square to the horizontal axis of the hub.
- (9) Support the wheel and keep the rim clear of the press bed by placing a parallel block between the bed of the press and the adjacent wheel nave. The block must be in full contact with the centre boss of the wheel and in no circumstances must it touch the outer flange. Failure to comply with this instruction may result in strain to the hub casting. Position a press tool RT28 in the liner and operate the press up to a maximum of $1\frac{1}{2}$ tons to press the liner home in the housing. There must be no end gap between the inner end of the liner and the abutment face of the housing; check this with a 0.0015 in. feeler gauge. Reverse the wheel and repeat the operation at the other side

using steel liner RP38/6B, press tool RT28 and a press loading of up to $2\frac{1}{2}$ tons.

- (10) Position the wheel in the lathe and set up as in (5). Machine the liner at the loose flange end to dimension "A" first and then to all other dimensions appropriate to the liner, except "B" given in RP38/5. The finished bore must be perfectly smooth and free from tool marks. Check against drawing dimensions.
- (11) Reverse the wheel in the lathe and set up as in (3). Machine the liner at the fixed flange end to all relative dimensions, including "B" given in RP38/5. The bore must be perfectly smooth and free from tool marks. Check against drawing dimensions.

Inspection

3. The repair must be to the satisfaction of the supervising inspector A.I.D., C.I.O./N.A.I. or C.I.O./A.I.S.

Painting

4. Repaint the hub as described in Vol. 1, Sect. 1, Chap. 1, para. 54.

Identification

5. After satisfactory completion of the repair use $\frac{1}{8}$ in. metal stamps to mark "RP38" below the assembly Issue No. on the wheel. After marking the wheel, paint the indentations with selenious acid solution.

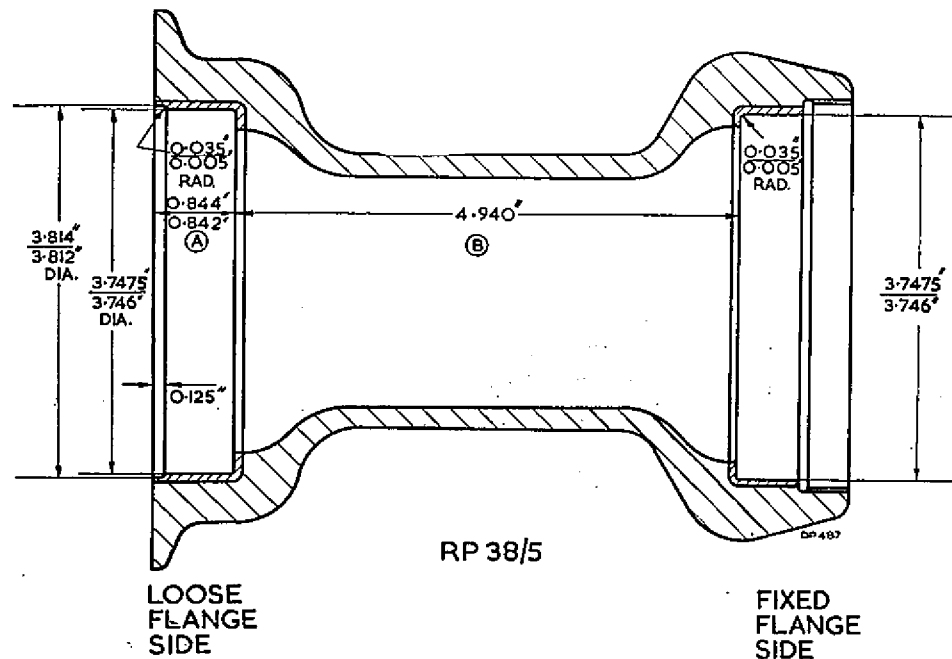

Fig. 2. Dimensions for machining fitted liners

RESTRICTED.

RP 40

REPAIR TO HOUSINGS FOR WHEEL BEARINGS

Equipment required

Lathe: Herbert No. 9B or its equivalent.
The speed for all turning operations to be approximately 100 r.p.m.

Press: Hydraulic or mechanical: press loading on liner at fixed flange end 3 tons maximum and on liner at loose flange end $3\frac{1}{2}$ tons maximum.

Press tools: Bearing liner punches, Part No. AO.100772 and AO.100773 (Table 2).

Selenious acid solution: 2 oz. selenious acid crystals dissolved in one pint of water.

New Parts. Liner, Part No. RP40/6A for bearing housing at fixed flange end, and liner, Part No. RP40/6B for bearing housing at loose flange end. The liners (Table 1) to be provided under unit arrangements.

WARNING

Selenious acid crystals or solution must not be allowed to come into contact with the skin.

Introduction

1. Due to various causes the housings for the wheel bearings may become enlarged to such an extent that the outer track of one or both bearings creeps. When this condition arises the affected housing(s) must be enlarged, and steel liner(s) fitted to restore the housing(s) to the original dimensions. Para. 2 details the procedure to be followed when both housings are affected; where only one housing is worn the appropriate sub-para. only will apply.

Method of repair

2. (1) Dismantle and degrease the wheel.
- (2) Remove the paint as described in Vol. 1, Sect. 1, Chap. 1, para. 53.
- (3) Mount the wheel casting in a lathe so that the chuck-jaws locate on the rim at the fixed flange end. It must then be set up so that the hub runs true in both the vertical and the horizontal planes. To check for truth apply a

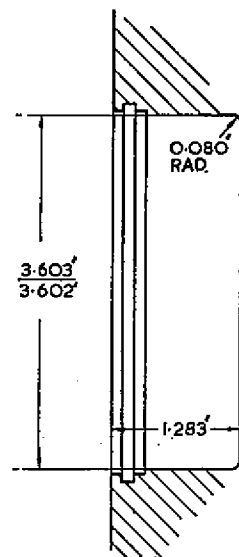

LOOSE FLANGE END

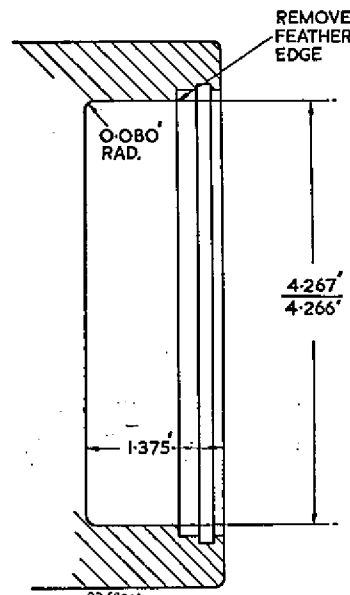

FIXED FLANGE END

RP 40/4

Fig. 1. Dimensions for machining bearing housings

RESTRICTED

(A.L.19, Mar. 54)

- dial test indicator to the tyre seat; the maximum permitted D.T.I. variation is 0.002 in.
- (4) Machine the bearing housing at the loose flange end of the wheel to the dimensions given in RP40/4 (fig. 1). Check against drawing dimensions.
 - (5) Reverse the wheel in the lathe and adjust the chucks to grip the rim at the side on which the loose flange fits, set up as described in (3) and machine the housing at the fixed flange end of the wheel to the dimensions given in RP40/4 (fig. 1). Check against drawing dimensions.
 - (6) Clean the machined surfaces and repair the chromate film (*A.P.2656A, Vol. I, Sect. 5, Chap. 2 refers*).
 - (7) Apply a thin coating of pigmented varnish jointing compound (*Stores Ref. 33C/1264*) to the machined surfaces of each bearing housing.
 - (8) Position the flanged end of the steel liner RP40/6A in the mouth of the bearing housing at the fixed flange end and ensure that it is perfectly square to the horizontal axis of the hub.
 - (9) Support the wheel and keep the rim clear of the press bed by placing a parallel block between the bed of the press and the adjacent wheel nave. The block must be in full contact with the centre boss of the wheel and in no circumstances must it touch the outer flange. Failure to comply with this instruction may result in strain to the hub casting. Position a press tool AO.100772 in the liner and operate the press up to a maximum of 3 tons to press the liner home in the housing. There must be no end gap between the inner end of the liner and the abutment face of the housing; check this with a 0.0015 in. feeler gauge. Reverse the wheel and repeat the operation at the other side using steel liner RP40/6B, press tool AO.100773 and a press loading of up to 3½ tons.
 - (10) Position the wheel in the lathe and set up as in (5). Machine the liner at the fixed flange end to dimension "A" first and then to all other dimensions appropriate to the liner, except "B" given in RP40/5 (fig. 2). The finished bore must be smooth and free from tool

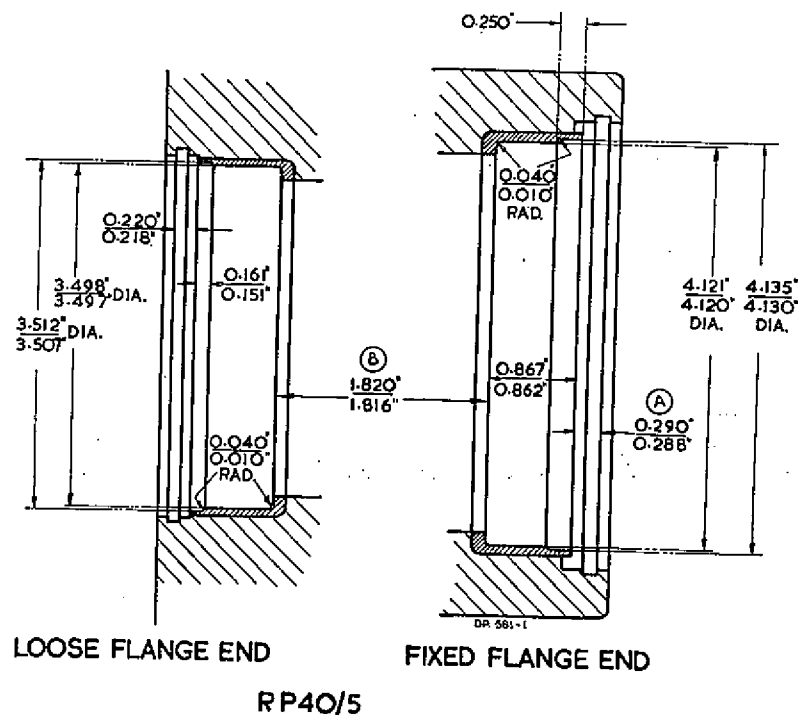

Fig. 2. Dimensions for machining fitted liners

RESTRICTED

marks. Check against drawing dimensions.

- (11) Reverse the wheel in the lathe and set up as in (3). Machine the liner at the loose flange end to all relative dimensions, including "B" given in RP40/5. The bore must be perfectly smooth and free from tool marks. Check against drawing dimensions.

Inspection

3. The repair must be to the satisfaction of the supervising inspector A.I.D., C.I.O./N.A.I., or C.I.O./A.I.S.

Painting

4. Repaint the hub as described in Vol. 1, Sect. 1, Chap. 1, para. 54.

Identification

5. After satisfactory completion of the repair use $\frac{1}{8}$ in. metal stamps to mark "RP 40" below the assembly Issue No. on the wheel. After marking the wheel, paint the indentations with selenious acid solution.

RP 41

REPAIR TO HOUSINGS FOR WHEEL BEARINGS

Requirements

Lathe: Herbert No. 9B or its equivalent.
The speed for all turning operations to be approximately 100 r.p.m.

Press: Hydraulic or mechanical: press loading on liner at fixed flange end 3 tons maximum and on liner at loose flange end $3\frac{1}{2}$ tons maximum.

Press tools: Bearing liner punches, Part No. AO.100772 and AO.100773 (Table 2).

Selenious acid solution: 2 oz. selenious acid crystals dissolved in one pint of water.

New parts: Liner, Part No. RP40/6A for bearing housing at fixed flange end, and liner, Part No. RP40/6B for bearing housing at loose flange end. The liners (Table 1) to be provided under Unit arrangements.

WARNING

Selenious acid crystals or solution must not be allowed to come into contact with the skin.

Introduction

1. Due to various causes the housings for the wheel bearings may become enlarged to such an extent that the outer track of one or both bearings creeps. When this condition arises the affected housing(s) must be enlarged, and steel liner(s) fitted to restore the housing(s) to the original dimensions. Para. 2 details the procedure to be followed when both housings are affected; where only one housing is worn the appropriate sub-para. only will apply.

Method of repair

2. (1) Dismantle and degrease the wheel.
- (2) Remove the paint as described in Vol. 1, Sect. 1, Chap. 1, para. 53.
- (3) Mount the wheel casting in a lathe so that the chuck-jaws locate on the rim at the fixed flange end. It must then be set up so that the hub runs true in both the vertical and the horizontal planes. To check for truth apply a dial test indicator to the tyre seat; the maximum permitted D.T.I. variation is 0.002 in.

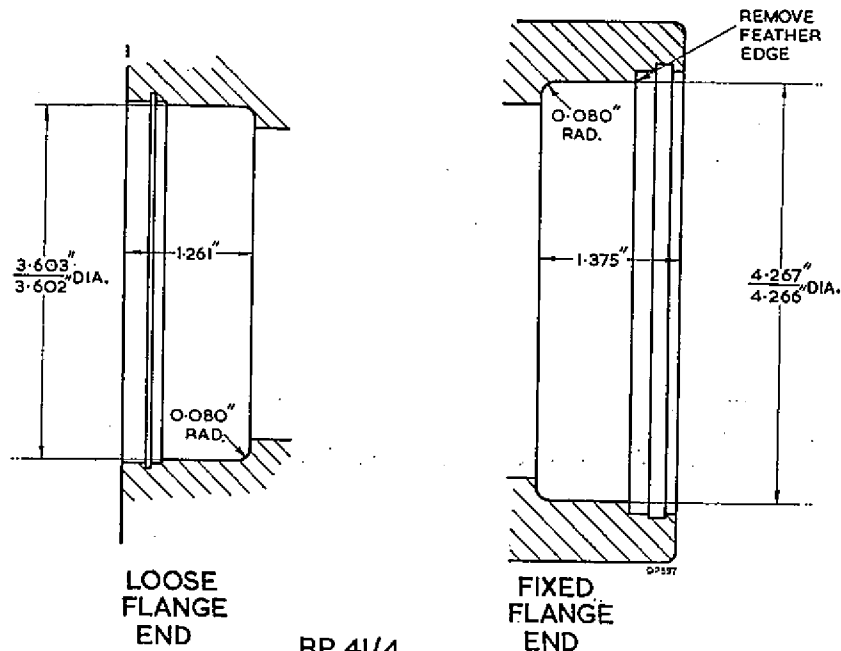

Fig. 1. Dimensions for machining bearing housings

(A.L.19, Mar. 54)

RESTRICTED

- (4) Machine the bearing housing at the loose flange end of the wheel to the dimensions given in RP41/4 (fig. 1). Check against drawing dimensions.
- (5) Reverse the wheel in the lathe and adjust the chucks to grip the rim at the side on which the loose flange fits, set up as described in (3) and machine the housing at the fixed flange end of the wheel to the dimensions given in RP41/4 (fig. 1). Check against drawing dimensions.
- (6) Clean the machined surfaces and repair the chromate film (*A.P.2656A, Vol. 1, Sect. 5, Chap. 2 refers*).
- (7) Apply a thin coating of pigmented varnish jointing compound (*Stores Ref. 33C/1264*) to the machined surfaces of each bearing housing.
- (8) Position the flanged end of the steel liner RP40/6A in the mouth of the bearing housing at the fixed flange end and ensure that it is perfectly square to the horizontal axis of the hub.
- (9) Support the wheel and keep the rim clear of the press bed by placing a parallel block between the bed of the press and the adjacent wheel nave.

The block must be in full contact with the centre boss of the wheel and in no circumstances must it touch the outer flange. Failure to comply with this instruction may result in strain to the hub casting. Position a press tool AO.100772 in the liner and operate the press up to a maximum of 3 tons to press the liner home in the housing. There must be no end gap between the inner end of the liner and the abutment face of the housing; check this with a 0.0015 in. feeler gauge. Reverse the wheel and repeat the operation at the other side using steel liner RP40/6B, press tool AO.100773 and a press loading of up to 3½ tons.

- (10) Position the wheel in the lathe and set up as in (5). Machine the liner at the fixed flange end to dimension "A" first and then to all other dimensions appropriate to the liner, except "B" given in RP41/5 (fig. 2). The finished bore must be smooth and free from tool marks. Check against drawing dimensions.
- (11) Reverse the wheel in the lathe and set up as in (3). Machine the liner at the loose flange end to all relative dimensions, including "B" given in RP41/5

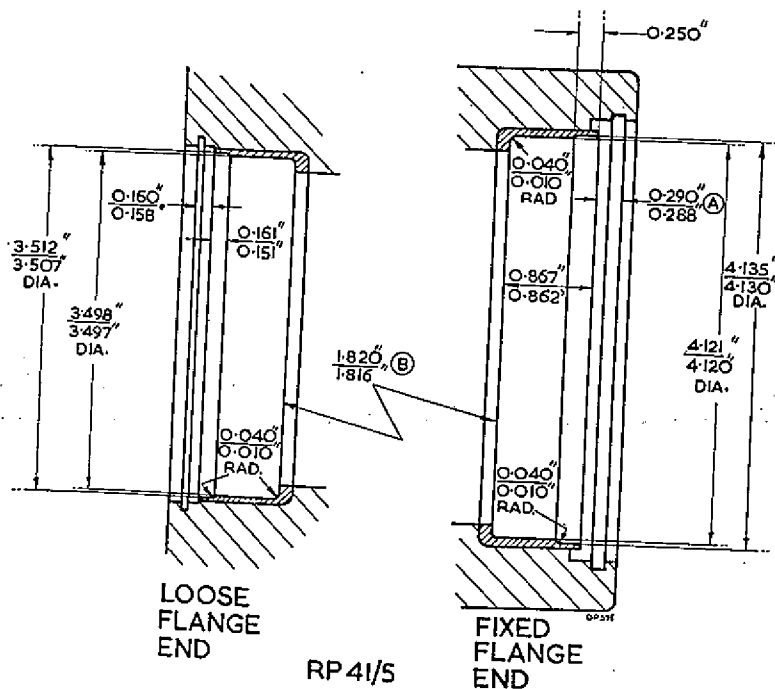

Fig. 2. Dimension for machining fitted liners

RESTRICTED

The bore must be perfectly smooth and free from tool marks. Check against drawing dimensions.

Inspection

3. The repair must be to the satisfaction of the supervising inspector A.I.D., C.I.O./N.A.I. or C.I.O./A.I.S.

Painting

4. Repaint the hub as described in Vol. 1, Sect. 1, Chap. 1, para. 54.

Identification

5. After satisfactory completion of the repair use $\frac{1}{8}$ in. metal stamps to mark "RP 41" below the assembly Issue No. on the wheel. After marking the wheel, paint the indentations with selenious acid solution.

RESTRICTED

(A.L.19, Mar. 54)

contact with
el and in no
ch the outer
y with this
train to the
press tool
operate the
f 3 tons to
ie housing.
etween the
abutment
his with a
everse the
ion at the
RP40/6B,
a press

e and set
er at the
"A" first
mensions
ept "B"
finished
rom tool
dimen-

and set
at the
dimen-
RP41/5

RP42

REPAIR TO HOUSINGS FOR WHEEL BEARING

Requirements

Lathe: Herbert No. 9B combination or its equivalent. The surface cutting speed for turning operations must be approximately 200 ft. per min. for the Elektron hub and 50 ft. per min. for the steel liners.

Press tools: Pressing-in sleeves, Part No. AO.50499, AO.68902
Mandrel and base, Part No. AO.42700
Collar, Part No. AO.42829

New Parts: Liners, Part No. RP42/8A and RP42/8B. The liners (Table 5) to be provided under unit arrangements.

Selenious acid solution: 2 oz. selenious acid crystals dissolved in one pint of water.

WARNING

Selenious acid crystals or solution must not be allowed to come into contact with the skin.

Introduction

1. Due to various causes, the housings for the wheel bearings may become so enlarged that the outer track of one or both bearings is loose in the housing. When this condition arises, the affected housing(s) must be enlarged and steel liner(s) fitted to restore the housing(s) to the original dimensions. Bearing creep in the housing is permissible provided the bearings are not loose in the housing.

Method of repair

2. (1) Dismantle and degrease the wheel.
- (2) Remove the paint as described in Vol. 1, Sect. 1, Chap. 1.
- (3) Mount the wheel casting in a lathe so that the chuck jaws locate on the fixed flange side of the wheel. Set up the wheel so that

it runs true in both vertical and horizontal planes. To check for truth, apply a dial test indicator to the hub of the bearing housing; the maximum permitted D.T.I. variation is 0.002 in.

- (4) Machine the bearing housing at the loose flange end of the wheel to the dimensions given in RP42/5 (fig. 1).
- (5) Reverse the wheel in the lathe and adjust the chucks to locate on the rim at the side on which the loose flange fits, set up as described in (3) and machine the housing at the fixed flange side of the wheel to the dimensions given in RP42/5 (fig. 1). Check against drawing dimensions.

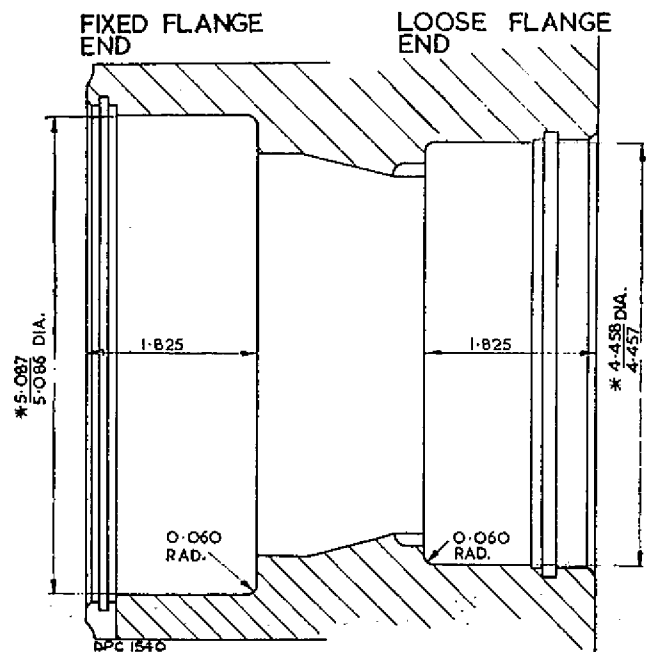

* MAXIMUM ECCENTRICITY BETWEEN THESE DIAMETERS TO BE 0.005
(ALL DIMENSIONS ARE IN INCHES)

RP 42/5

Fig. 1. Machining of bearing housings

(A.L.45, July 56)

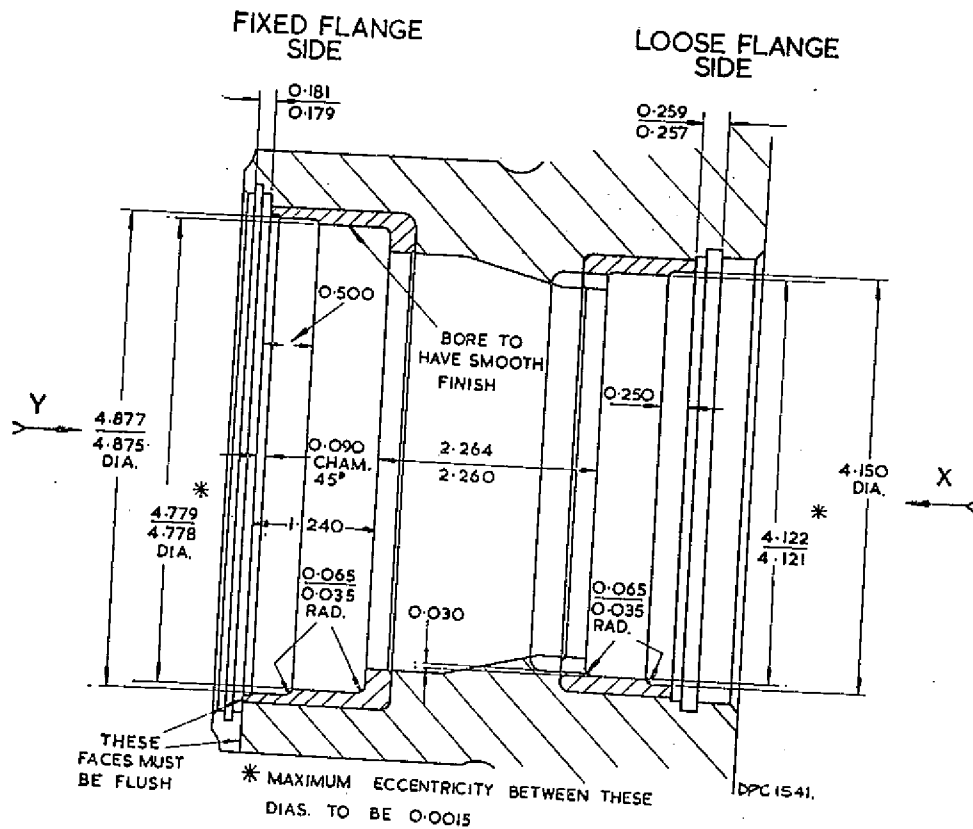

RP 42/6
(ALL DIMENSIONS ARE IN INCHES)

Fig. 2. Machining of fitted liners

- (6) Clean the machined surfaces and repair the chromate film (*A.P.2656A, Vol. 1, Sect. 5, Chap. 2*).
- (7) Heat the hub to a temperature of 100 deg. C. by immersing it in boiling water. While the hub retains its heat, quickly dry it, and coat the exterior surfaces of the liners with a thin coating of pigmented varnish jointing compound (*Stores Ref. 33C/1264*).
- (8) Position the mandrel and base on the press, place the liner RP42/8A around the appropriate sleeve, then pass the sleeve over the mandrel.
- (9) Position the wheel, loose flange end uppermost, over the mandrel. Place the other liner RP42/8B around the top sleeve, then pass the sleeve over the mandrel.
- (10) Lower the collar over the mandrel and press the liners into the hub. There must be no gap between the inner ends of the liners and the respective abutment faces of the housings; check this with a 0.0015 in. feeler gauge.
- (11) Position the wheel in the lathe and set up as in (3). Machine the liner at the loose flange end to the dimensions given in RP42/6 (*fig. 2*). The finished bore must be smooth and free from tool marks. Check against drawing dimensions.
- (12) Reverse the wheel in the lathe and set up as in (5). Machine the liner at the fixed flange end to the dimensions given in RP42/6. The bore must be perfectly smooth and free from tool marks. Check against drawing dimensions.

RESTRICTED.

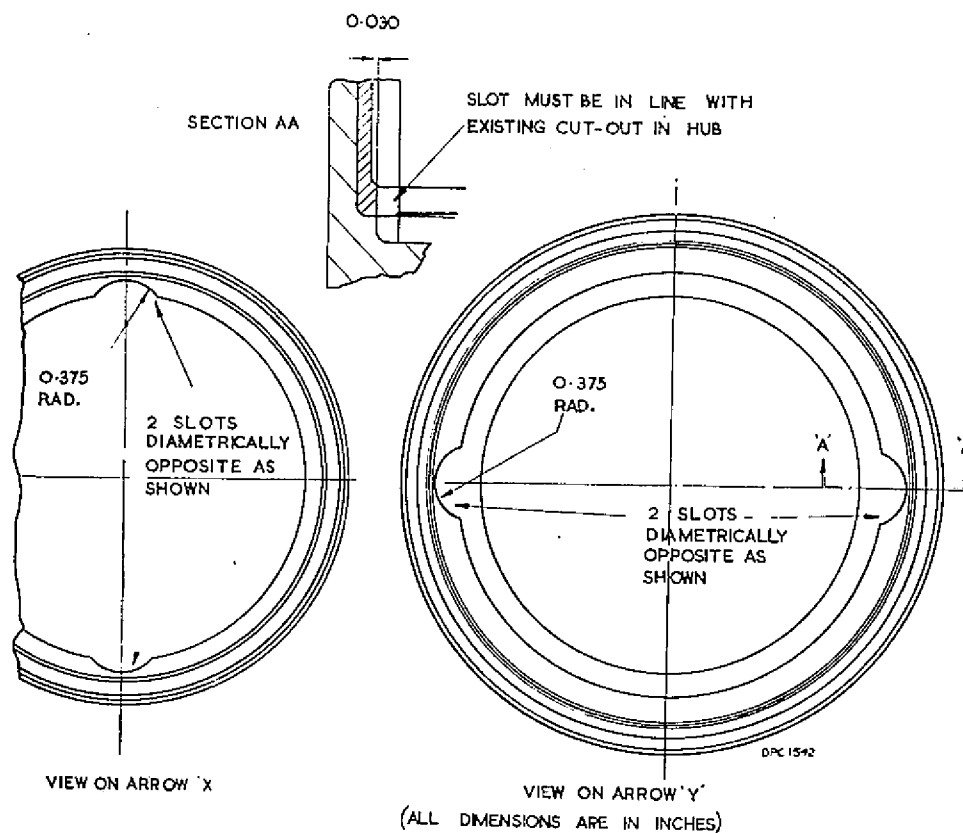

Fig. 3. Machining of extractor slots

- (13) Set up the casting endwise on the table of a vertical miller so that the cutter will ultimately engage the existing extractor slots. Using a 0.750 in. dia. end mill, machine the two slots as in RP42/6 and RP42/7 (fig. 3) to conform with the bearing extractor slots.
- (14) Reverse the wheel casting and repeat operation (13) at the other side of the hub.
- (15) Remove all burrs from the slots and check that the slots conform to drawing requirements.

Inspection

3. The repair must be to the satisfaction of the supervising inspector A.I.D., C.I.O./N.A.I. or C.I.O./A.I.S.

Painting

4. Repaint the hub as described in Vol. 1, Sect. 1, Chap. 1.

Identification

5. After satisfactory completion of the repair use $\frac{1}{8}$ in. metal stamps to mark "RP41" below the Assembly Issue No. on the wheel. After marking the wheel, paint the indentations with selenious acid solution.

MINISTRY OF SUPPLY
 CENTRAL
 LIBRARY

RP44

CONVERSION OF WHEELS

PART No. AH.9006 and AH.9489

Equipment required:

Lathe: Herbert No. 9B combination or its equivalent.

Press tool: Pressing-in tool, Part No. AO.59053.

Selenious acid solution: 2 oz. selenious acid crystals dissolved in one pint of water.

WARNING

Selenious acid crystals or solution must not be allowed to come into contact with the skin.

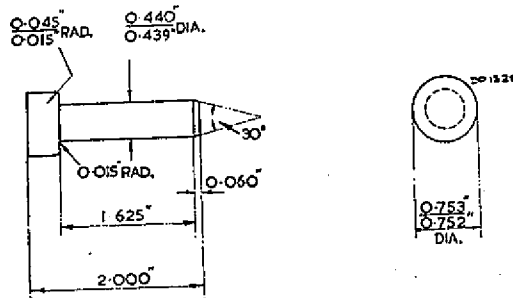

PLUG RP44/3
 (MATERIAL - ELEKTRON
 SPEC - DTD. 259
 FINISH - CHROMATE TO STD. 911)

Fig. 1. Details of plugs

Introduction

1. This repair scheme details the instructions required to convert main landing wheels AH.9489 to AH.50273, wheels AH.9006 (issues 1 to 6 inclusive) to AH.50579, and wheels AH.9006 (issues 7 and onwards) to AH.50273.

Method of repair

2. (1) Dismantle and degrease the wheel.
- (2) Remove the paint as described in Vol. 1, Sect. 1, Chap. 1.
- (3) Apply a thin coating of pigmented varnish jointing compound (*Stores Ref. 33C/1264*) to the plugs, Part No. RP44/3 (*fig. 1*) and drive them into the holes in the hub.

- (4) Mount the wheel casting in a lathe so that the chuck-jaws grip the rim at the loose flange side of the wheel. It must then be set up so that the hub runs true in both vertical and the horizontal planes. To check for truth, apply a dial test indicator to the hub of the bearing housing; the maximum permitted D.T.I. variation is 0.002 in.
- (5) Machine the central projection of the wheel to the dimensions given in RP44/4 (*fig. 2*).
- (6) Reverse the wheel and secure it in the lathe by locating the fixed flange end, set up as described in (4) and machine it to the dimensions given in RP44/4 (*fig. 2*). Check against drawing dimensions.
- (7) Remove the wheel from the lathe, then drill and ream the nine holes as shown in RP44/5 (*fig. 3*).
- (8) Clean the machined surfaces and repair the chromate film (*A.P.2656A, Vol. 1, Sect. 5, Chap. 2*).
- (9) Heat the hub to a temperature of 100 deg. C by immersing it in boiling water. While the hub retains its heat, quickly dry it and apply a thin coat of Adhesive, synthetic resin, No. 103 (*Stores Ref. 33C/1371*) with Hardener, 951 (*Stores Ref. 33C/1372*) to the bore. Align the holes in the hub and in the bearing housing, Part No. AH.40484, then press the bearing housing into position using pressing-in tool, Part No. AO.59053.
- (10) Refer to RP44/6 (*fig. 4*), and ream and chamfer the nine holes.
- (11) Secure the bearing housing to the hub using the bolts, Part No. AHO.35730, the washers, Part No. AHO.35728, and the nuts, Part No. AHO.35707. Tighten the nuts with a torque spanner to a torque of 35 lb. ft. Peen over the end of each bolt into both slots in the nut.

(A.L.37, Feb. 56)

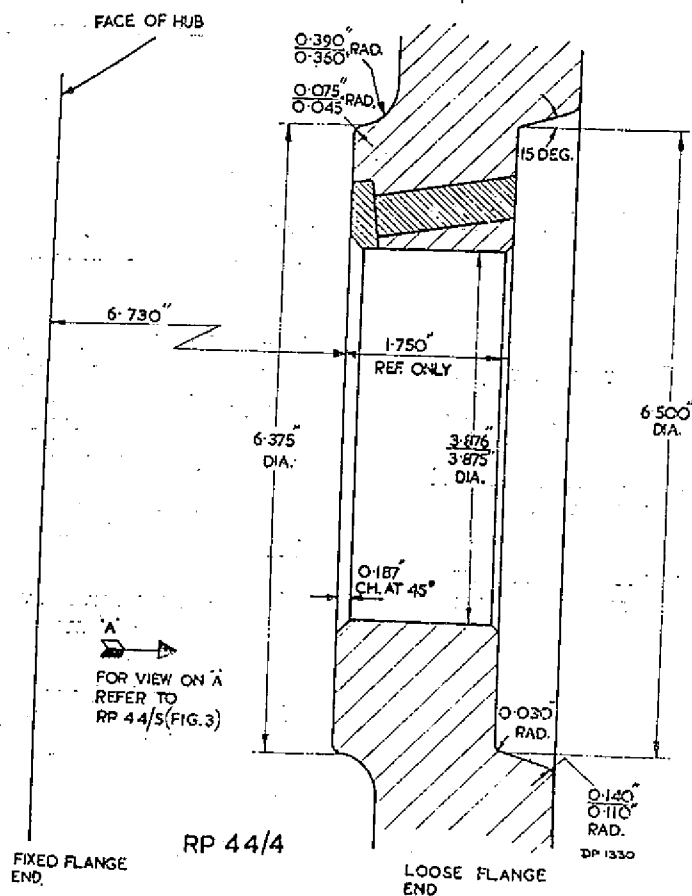

Fig. 2. Machining of bearing housings

- (12) Mount the wheel casting in a lathe so that the chuck-jaws locate on the rim at the loose flange side. It must then be set up so that the hub runs true in both the vertical and horizontal planes. To check for truth, apply a dial test indicator to the hub of the bearing housing, the maximum D.T.I. variation permitted is 0.002 in.
- (13) Machine the bearing housing at the fixed flange end of the wheel to the dimensions given in RP44/6 (fig. 4).
- (14) Reverse the wheel and secure it in the lathe by locating the fixed flange end, set up as described in (12) and machine the bearing housing to the dimensions given in RP44/6 (fig. 4). The bore must be perfectly smooth and free from tool marks. Check against drawing dimensions.
- (15) Clean the machined surfaces and apply a protective coating of pigmented varnish jointing compound (Stores Ref. 33C/1264).

Inspection

3. The repair must be to the satisfaction of the supervising inspector A.I.D., C.I.O./N.A.I. or C.I.O./A.I.S.

Painting

4. Repaint the hub as described in Vol. 1, Sect. 1, Chap. 1.

Identification

5. After satisfactory completion of the repair use $\frac{1}{8}$ in. metal stamps to mark "RP44" below the Assembly Issue No. on the wheel. After marking the wheel, paint the indentations with selenious acid solution.

RESTRICTED

VIEW IN DIRECTION OF ARROW A
(REFER TO RP44/4 FIG.2)

9 HOLES DRILL $\frac{0.439}{0.437}$ DIA.
EQUALLY SPACED AS SHOWN
WITH REGARD TO PLUGGED HOLES.
HOLES TO BE WITHIN .001" OF NOM.
POSITION.

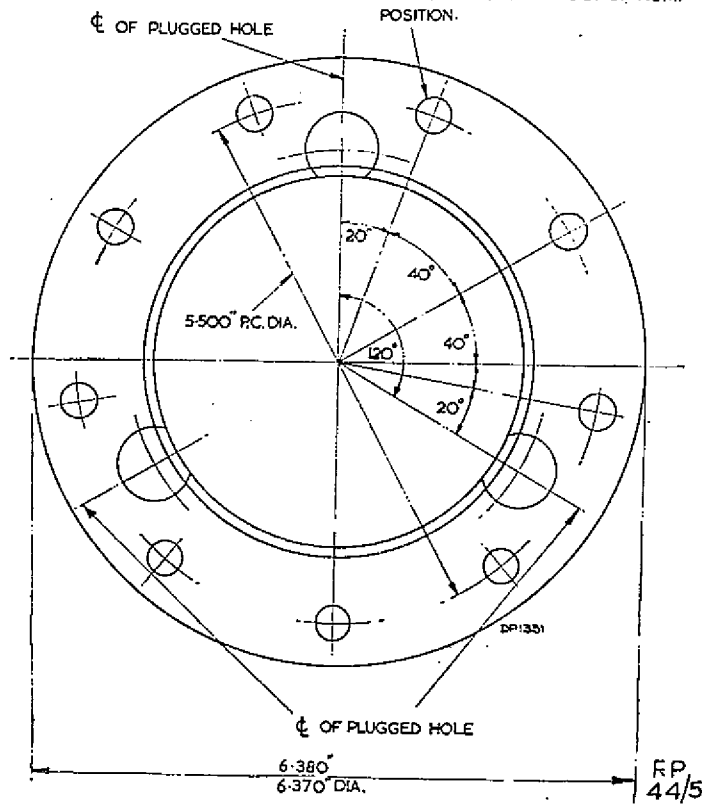

Fig. 3. Dimension of bearing attachment bolt holes

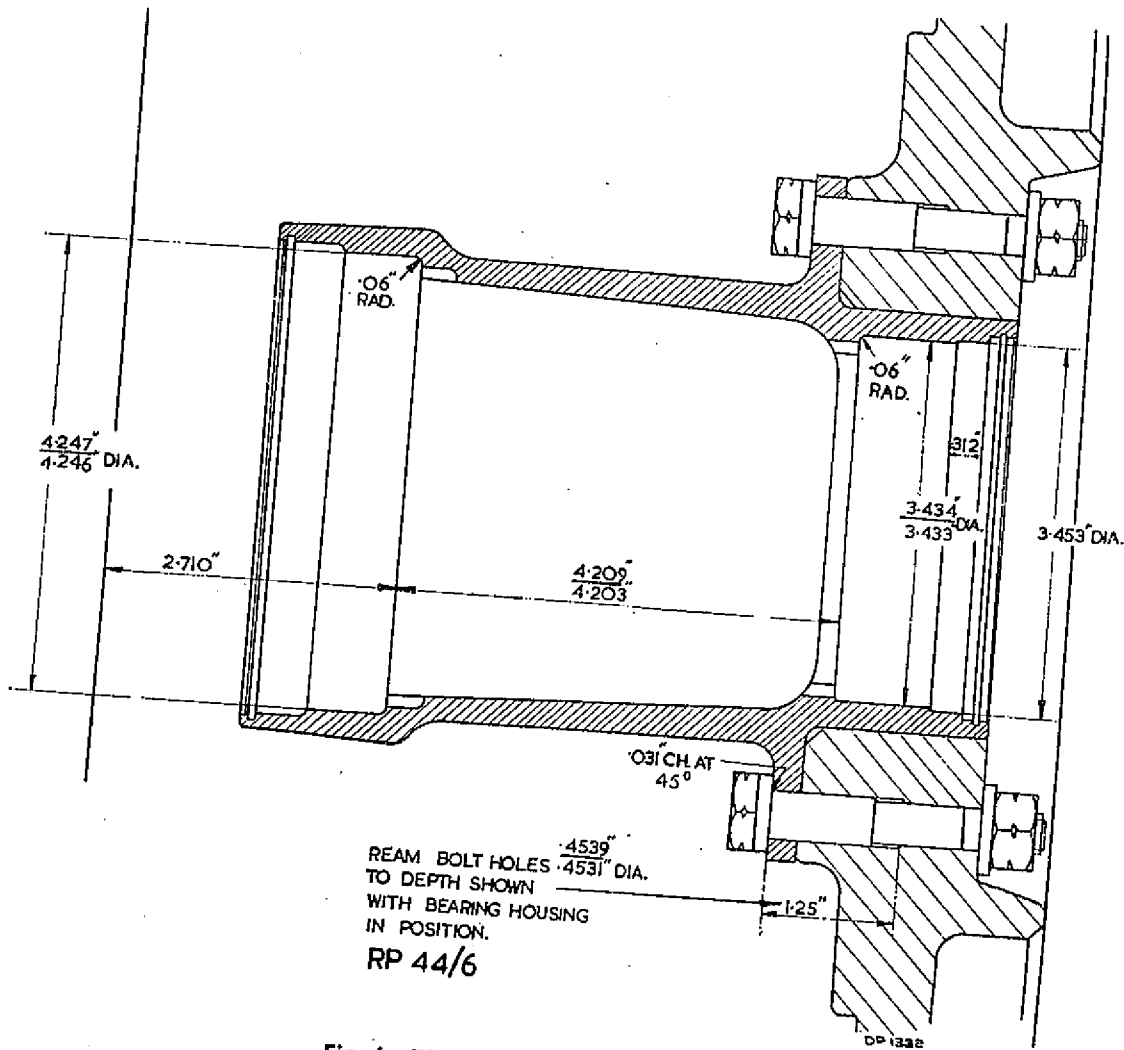

Fig. 4. Dimensions of bearing housing

RP 45
RECLAMATION OF BI-METAL BRAKE DRUMS

1. The brake drums listed in App. 2, Table 3 may be reclaimed by grinding if they are within the stated repair limits.
2. It is unimportant if the spigot bore diameter does not clean up all round provided that the bore diameter is not less than the dimension stated.
3. The reclaimed brake drum must conform with the limits given in Table 3.
4. When the brake drum AHO.25185 has been reclaimed it must be re-numbered AHO.35345 and identified by painting the outside edge with yellow paint.
5. The repair must be to the satisfaction of the Supervisory Inspector A.I.D., C.I.O./N.A.I. or C.I.O./A.I.S.
6. After satisfactory completion of the repair use $\frac{1}{8}$ in. metal stamps to mark "RP45" adjacent the issue number on the brake drum.

RP55

REPAIR TO HOUSINGS FOR WHEEL BEARINGS

Requirements**Lathe:**

Herbert No. 9B combination or its equivalent. The surface cutting speed for turning operations must be approximately 200 ft. per min. for the Elektron hub and 50 ft. per minute for the steel liners.

Press tools:

Pressing-in sleeves Part No. AO.101255
Mandrel and base Part No. AO.42469
Collar Part No. AO.45784

New parts:

Liners, Part No. RP55/3. The liners (Table 1) to be provided under unit arrangements.

Selenious acid solution:

2 oz. selenious acid crystals dissolved in one pint of water.

WARNING

Selenious acid crystals or solution must not be allowed to come into contact with the skin.

Introduction

1.—Due to various causes, the housings for the wheel bearings may become so enlarged

that the outer track of one or both bearings is loose in the housing. When this condition arises, the affected housing(s) must be enlarged and steel liner(s) fitted to restore the housing(s) to the original dimensions. Bearing creep in the housing is permissible provided the bearings are not loose in the housing.

Method of repair

2. (1) Dismantle and degrease the wheel.
- (2) Remove the paint as described in Vol. 1, Sect. 1, Chap. 1.
- (3) Mount the wheel casting in a lathe so that the chuck jaws locate on the fixed flange side of the wheel. Set up the wheel so that it runs true in both the vertical and horizontal planes. To check for truth, apply a dial test indicator to the hub of the bearing housing; the maximum permitted D.T.I. variation is 0.002 in.
- (4) Machine the bearing housing at the loose flange end of the wheel to the dimensions given in RP55/1 (fig. 1).

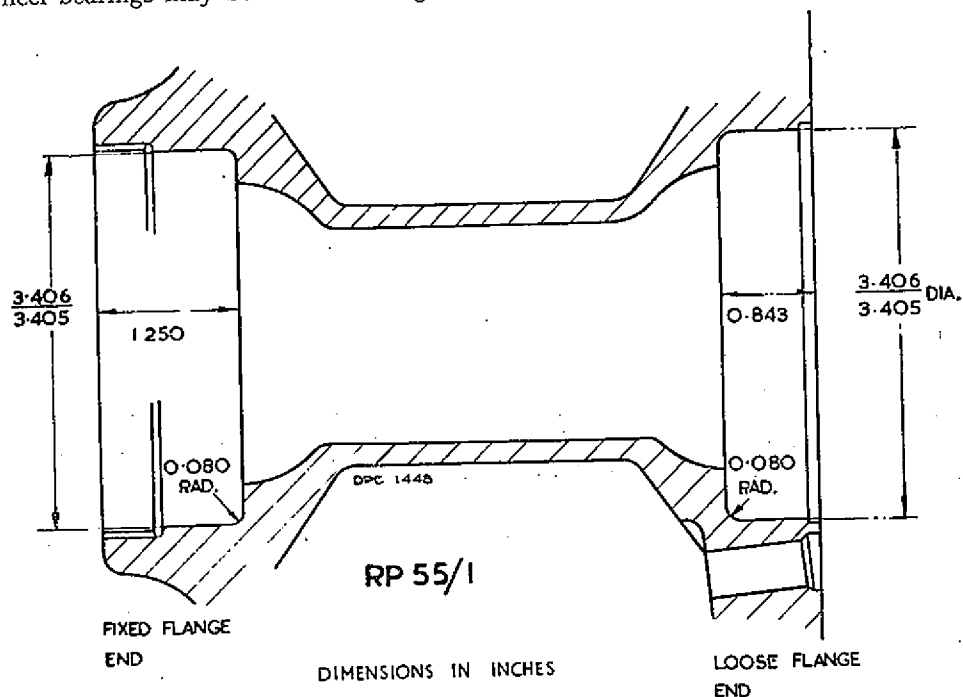

Fig. 1. Dimensions for machining housings

(A.L.40, Mar., 56)

- (5) Reverse the wheel in the lathe and adjust the chuck jaws to locate on the rim at the side on which the loose flange fits, set up as described in (3) and machine the housing at the fixed flange side of the wheel to the dimensions given in RP55/1 (fig. 1). Check against drawing dimensions.
- (6) Clean the machined surfaces and repair the chromate film (A.P.2656A, Vol. 1, Sect. 5, Chap. 2).
- (7) Heat the hub to a temperature of 100 deg. C. by immersing it in boiling water. While the hub retains its heat, quickly dry it, and coat the exterior surfaces of the liners with a thin coating of pigmented varnish jointing compound (Stores Ref. 33C/1264).
- (8) Position the mandrel and base on the press, place the liner RP55/3 around the appropriate sleeve, then pass the sleeve over the mandrel.
- (9) Position the wheel loose flange end uppermost over the mandrel, place the other liner around the top sleeve, then pass the sleeve over the mandrel.
- (10) Lower the collar over the mandrel and press the liners into the hub. There must be no gap between the inner ends of the liners and the respective abut-

ment faces of the housings; check this using a 0.0015 in. feeler gauge.

- (11) Position the wheel in the lathe and set up as in (3). Machine the liner at the loose flange end to the dimensions given in RP55/2 (fig. 2). The finished bore must be smooth and free from tool marks. Check against drawing dimensions.
- (12) Reverse the wheel in the lathe and set up as in (5). Machine the liner at the fixed flange end to the dimensions given in RP55/2. The bore must be perfectly smooth and free from tool marks. Check against drawing dimensions.

Inspection

3. The repair must be to the satisfaction of the supervising inspector A.I.D., C.I.O./N.A.I. or C.I.O./A.I.S.

Painting

4. Repaint the hub as described in Vol. 1, Sect. 1, Chap. 1.

Identification

5. After satisfactory completion of the repair use $\frac{1}{8}$ in. metal stamps to mark "RP55" below the assembly Issue No. on the wheel. After marking the wheel, paint the indentations with selenious acid solution.

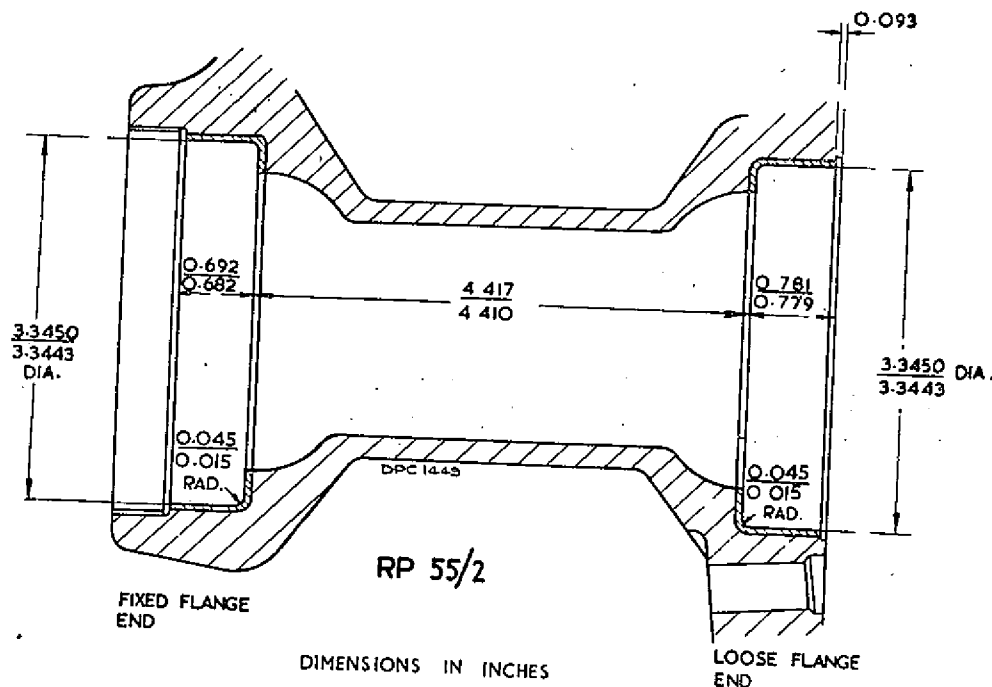

Fig. 2. Dimensions for machining fitted liners

RESTRICTED

Requir
Lath

Vert.
Pres
Pres

New

Sele
acid
solu

W/
S
n
c

Intr
I.
hou
ma
out
ma
ari
mu
fit
to

Me
2.

(2

(3

F

RP57 REPAIR TO HOUSINGS FOR WHEEL BEARINGS

Requirements:
Lathe:

Herbert No. 9B combination or its equivalent. The surface cutting speed for turning operations must be approximately 200 ft. per min. for the Elektron hub and 50 ft. per min. for the steel liners.

Vertical milling machine:

Press: Hydraulic or mechanical.

Press tools: Bearing liner punches, Part No. AO.101246.

New Parts: Liner, Part No. RP57/2. The liners (Table 1) to be provided under unit arrangements.

Selenious acid solution:

2 oz. selenious acid crystals dissolved in one pint of water.

WARNING

Selenious acid crystals or solution must not be allowed to come into contact with the skin.

Introduction

1. Due to various causes, the housings for the wheel bearings may become so enlarged that the outer track of one or both bearings may creep. When this condition arises, the affected housing(s) must be enlarged and steel liner(s) fitted to restore the housing(s) to their original dimensions.

Method of repair

- (1) Dismantle and degrease the wheel.
- (2) Remove the paint as described in Vol. 1, Sect. 1, Chap. 1.
- (3) Mount the wheel casting in a lathe so that the chuck jaws locate on the rim at the side on which the loose flange fits. It must then be set up so that the hub runs true in both the vertical and horizontal planes. To check for truth, apply a dial

test indicator to the hub of the bearing housing; the maximum permitted D.T.I. variation is 0.002 in.

- (4) Machine the bearing housing at the fixed flange end of the wheel to the dimensions given in RP57/1 (fig. 1).
- (5) Reverse the wheel in the lathe and adjust the chucks to grip the fixed flange, set up as described in (3), and machine the housing at the loose flange end of the wheel to the dimensions given in RP57/1

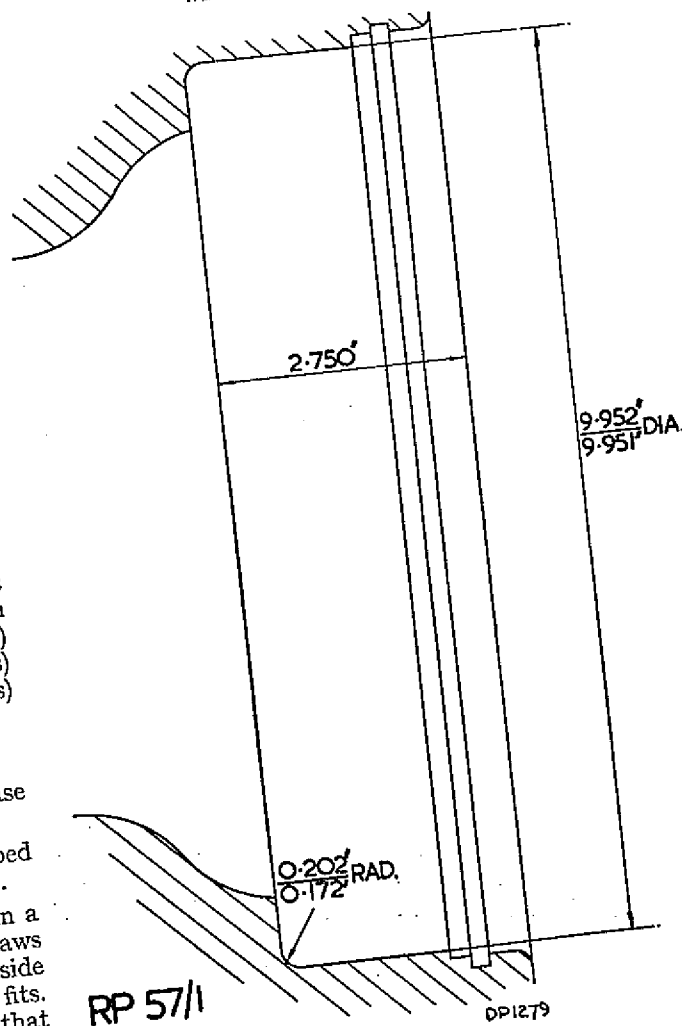

Fig. 1. Dimensions for machining housings (A.L.33, Oct. 55)

RESTRICTED

- (fig. 1). Check against drawing dimensions.
- (6) Clean the machined surfaces and repair the chromate film (A.P.2656A, Vol. 1, Sect. 5, Chap. 2).
 - (7) Heat the hub to a temperature of 100 deg. C by immersing it in boiling water. While the hub retains its heat, quickly dry it, and coat the exterior surfaces of the liners with a thin coating of pigmented varnish jointing compound (Stores Ref. 33C/1264).
 - (8) Place the flanged end of the steel liner RP57/2 in the mouth of the bearing housing at the fixed flange end of the wheel and ensure that it is square to the horizontal axis of the hub.
 - (9) Support the wheel and keep the rim clear of the press bed by placing a parallel block between the bed of the press and the adjacent wheel nave. The block must be in full contact with the centre boss of the wheel and in no circumstances must it touch the outer flange. Failure to comply with this instruction may result in strain to the hub casting.
 - (10) Position the punch AO.101246 in the liner and operate the press to guide the liner into the housing.
 - (11) Reverse the wheel and repeat the operation at the opposite side using the other steel liner RP57/2 and punch AO.101246. There must be no gap between the inner ends of the liners and the respective abutment faces of the housings; check this with a 0.0015 in. feeler gauge.
 - (12) Position the wheel in the lathe and set up as in (3). Machine the liner at the fixed flange end to the dimensions given in RP57/3 (fig. 2). The finished bore must be smooth and free from tool marks. Check against drawing dimensions.
 - (13) Reverse the wheel in the lathe and set up as in (5). Machine the liner at the loose flange end to all relative dimensions given in RP57/3. The bore must be

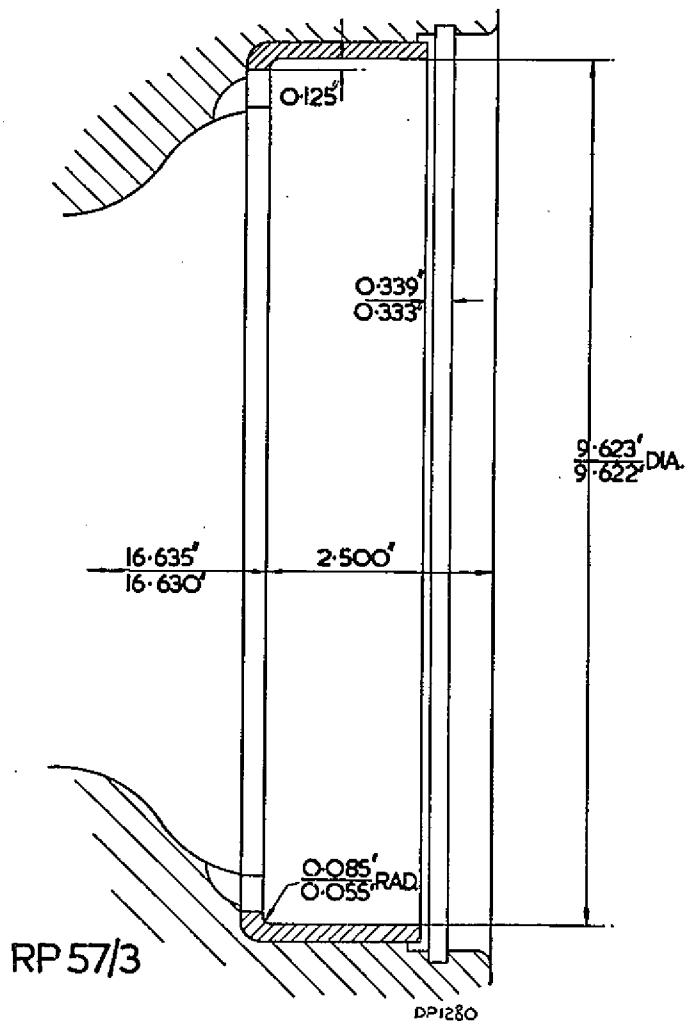

Fig. 2. Dimensions for fitted liners

perfectly smooth and free from tool marks. Check against drawing dimensions.

- (14) Set the wheel up on the table of a vertical miller and position it so that the cutting tool will ultimately re-engage the existing extractor slots in the fixed flange end of the wheel. Using a $1\frac{1}{4}$ in. dia. end mill, mill two slots as shown in RP57/4 (fig. 3) to conform with the existing extractor slots. There must be a clearance of 0.120/0.130 in. between the inside dia. of the bearing housing and the edge of the slot (fig. 2).
- (15) The extractor slots may alternatively be machined in the bearing liner by the use of a drill jig and an appropriate end cutting tool.

RESTRICTED.

(16) Carefully remove all burrs from the extractor slots and check that the slots conform to drawing requirements. Paint the freshly machined surfaces of the hub with selenious acid solution.

Inspection

3. The repair must be to the satisfaction of the supervising inspector A.I.D., C.I.O./-N.A.I. or C.I.O./A.I.S.

Painting

4. Repaint the hub as described in Vol. 1, Sect. 1, Chap. 1, para. 54.

Identification

5. After satisfactory completion of the repair, use $\frac{1}{8}$ in. metal stamps to mark "RP57" below the assembly Issue No. on the wheel. After marking the wheel, paint the indentations with selenious acid solution.

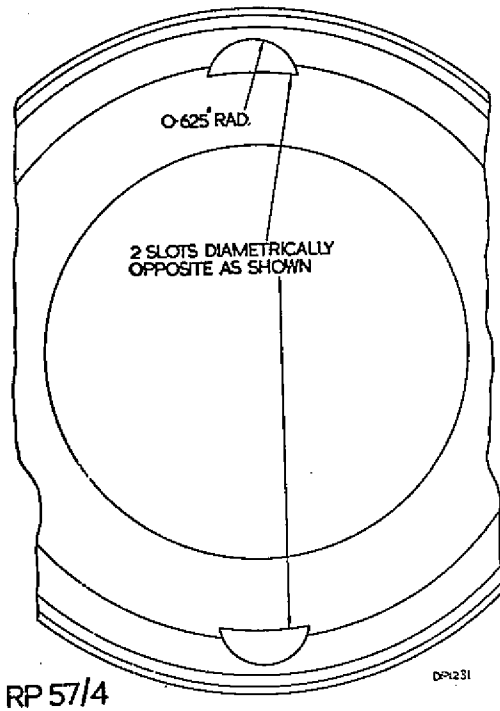

Fig. 3. Dimensions for milling of slots

1
59

of
2./

1

RESTRICTED

(A.L.33, Oct. 55)

F.S./2

P25296 587608/7143 1/56 1750 C & P Gp.1

RP 60

REPAIR TO HOUSINGS FOR WHEEL BEARINGS

Requirements

Lathe Herbert No. 21 combination or its equivalent. The surface speed for turning operations must be 200 ft. per minute.

Press Hydraulic or mechanical.

Press tools Mandrel and base assembly, Part No. AO.42699; Sleeves, Part No. AO.42204 and AO.42206; Collar, Part No. AO.42829.

New parts Shims RP 60/2 (fixed flange end) and RP 60/5 (loose flange end).

Selenious acid solution 2 oz. Selenious acid crystals dissolved in one pint of water.

WARNING

Selenious acid crystals or solution must not be allowed to come into contact with the skin.

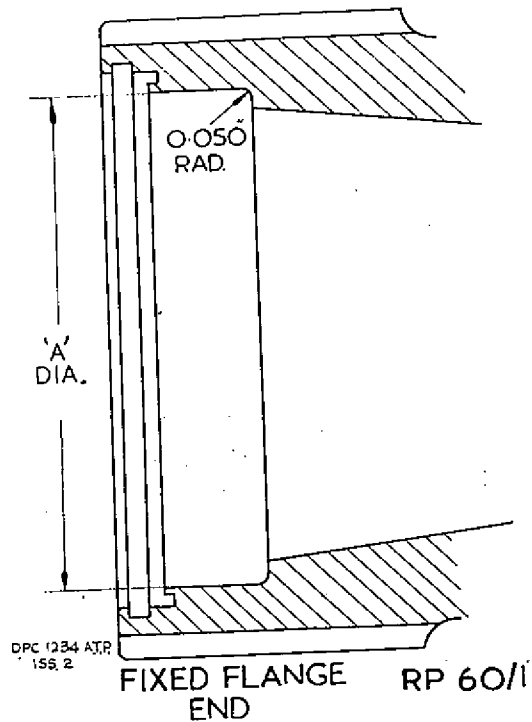

Fig. 1. Dimensions for machining bearing housings (1)

Introduction

1. Due to various causes, the housings for the wheel bearings may become so enlarged that the outer track of one or both bearings will creep. When this condition arises, the affected housing(s) must be enlarged and steel shim(s) fitted to restore the housing(s) to its (their) original dimension(s).

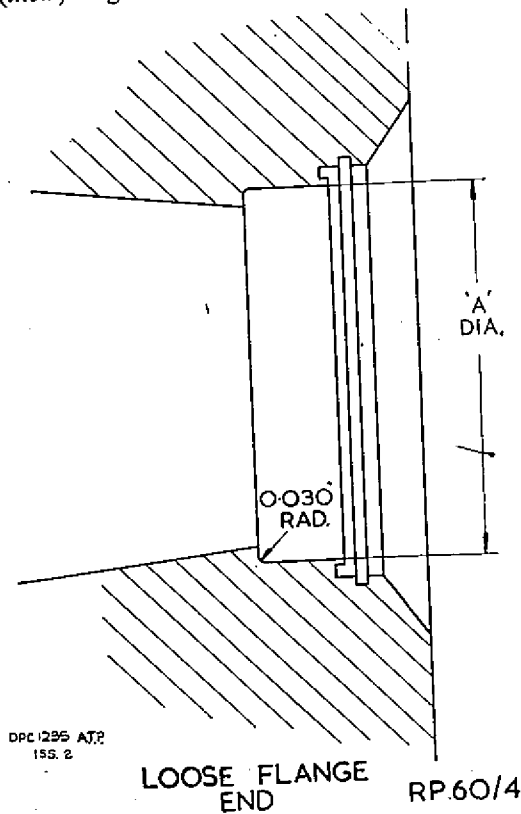

Fig. 2. Dimensions for machining bearing housings (2)

2. Two stages of repair are permitted. Thus when a first stage repair is not possible because the housing cannot be enlarged within the maximum limit, the second stage repair may be accomplished. A shim of greater thickness is used for the second stage repair as shown in Table 4 of the chapter. The following table gives the machining diameters of A shown in fig. 1 and fig. 2.

~~RESTRICTED~~

TABLE 1

Dimensions for machining bearing housings

Location	1st stage reclaim A in. dia.	2nd stage reclaim A in. dia.
Fixed flange end RP 60/1	4.149	4.154
	4.148	4.153
Loose flange end RP 60/4	3.524	3.529
	3.523	3.528

Method of repair

3. (1) Dismantle and degrease the wheel.
- (2) Remove the paint as described in Vol. 1, Sect. 1, Chap. 1.
- (3) Mount the wheel casting in a lathe so that the chuck-jaws locate on the rim at the side on which the loose flange fits. Set up the wheel so that the hub runs true in both the vertical and horizontal planes. To check for truth, apply a dial test indicator to the bearing housing; the maximum D.T.I. variation is 0.002 in.

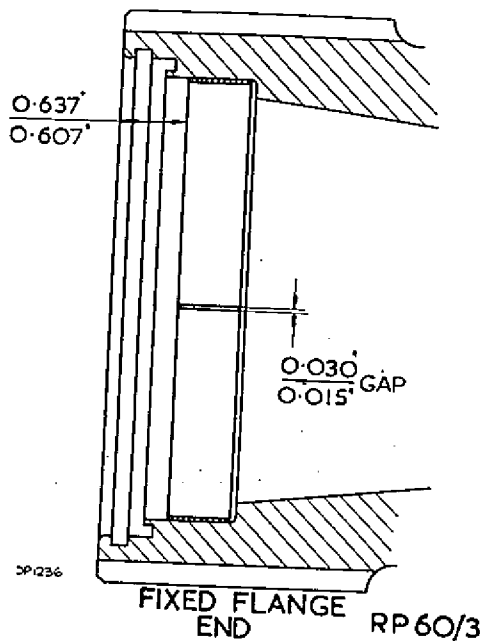

Fig. 3. Clearance dimensions of fitted shim (1)

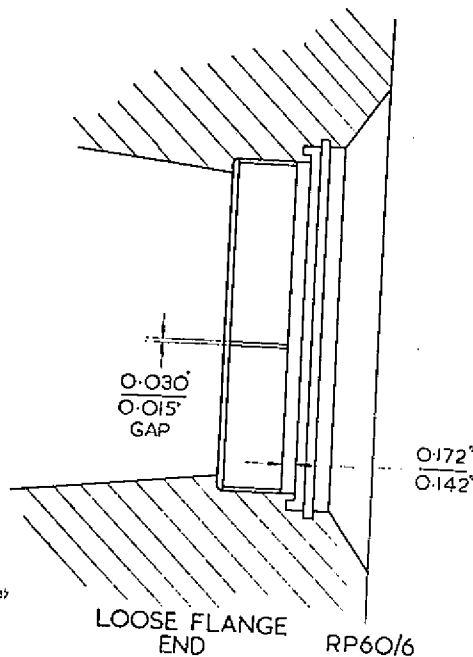

Fig. 4. Clearance dimensions of fitted shim (2)

- (4) Machine the bearing housing at the fixed flange end of the wheel to the dimensions given in RP 60/1 (fig. 1). Check against drawing dimensions.
- (5) Reverse the wheel in the lathe and adjust the chuck-jaws to grip the fixed flange, set up as described in (3) and machine the housing at the loose flange end to the dimensions given in RP 60/4 (fig. 2). Check against drawing dimensions.
- (6) Clean the machined surfaces and repair the chromate film (A.P.2656A, Vol. 1, Sect. 5, Chap. 2).
- (7) Heat the hub to a temperature of 100 deg. C. by immersing it in boiling water. While the hub retains its heat quickly dry it and apply a thin coating of pigmented varnish jointing compound (Ref. 33C/1264) to the machined surfaces of the bearing housings.
- (8) Insert the shims RP 60/2 and RP 60/5 (refer to Table 4 for details) and position them as shown in RP 60/3 (fig. 3) and RP 60/6 (fig. 4). Check against drawing dimensions.

RESTRICTED

- (9) Position the mandrel and base on the press, place the bearing around the appropriate sleeve, then pass the sleeve over the mandrel.
- (10) Position the wheel loose flange end uppermost over the mandrel, place the other bearing around the top sleeve then pass the sleeve over the mandrel.
- (11) Lower the collar over the mandrel and press the bearings into the hub. Check the dimensions shown on RP60/3 (fig. 3) and RP60/6 (fig. 4).

Inspection

4. The repair must be to the satisfaction of the supervising inspector A.I.D., C.I.O./N.A.I. or C.I.O./A.I.S.

Painting

5. Repaint the hub as described in Vol. 1, Sect. 1, Chap. 1.

Identification

6. After satisfactory completion of the repair use $\frac{1}{8}$ in. metal stamps to mark "RP60" below the assembly issue number of the wheel. After marking the wheel, paint the indentations with selenious acid solution.

O-172*
O-142*

/6

itted

at the
to the
fig. 1).
ns.

e and
> fixed
) and
flange
P 60/4
limen-

repair
Vol. 1,

of 100
water.
quickly
ng of
pound
d sur-

P 60/5
osition
3) and
rawing

RP 70

REPAIR TO WHEEL BRAKE DRUM

Requirements

Lathe: Herbert No. 9B combination or its equivalent.

Press tools: Pressing in adapter, Part No. AO.32273.

New Parts: AHO.23327 Brake drum 1 off.
AS.157/810 Rivet 8 off.

Selenious acid solution: 2 oz. selenious acid crystals dissolved in one pint of water.

WARNING

Selenious acid crystals or solution must not be allowed to come into contact with the skin.

Introduction

1. Due to various causes the brake drum may become scored to such an extent that it is considered unserviceable. When this occurs, the wheel is to be repaired by renewal of the brake drum.

Method of repair

2. (1) Dismantle and degrease the wheel. The bearing cups may remain in position in the hub but during the repair they should be protected by masking tape.
- (2) Remove the eight rivets securing the brake drum to the hub.
- (3) Mount the hub in a lathe so that the chuck jaw locates on the outside diameter of the flange at the end opposite to the brake drum. Set up the hub so that it runs true in both the vertical and horizontal planes. To check for truth, apply a dial test indicator to the hub; the maximum permitted D.T.I. variation is 0.002 in.
- (4) Machine the brake drum wall until it is reduced to a thin layer of metal which may be peeled away from the hub. Care must be exercised during this machining operation to prevent the cutting tool contacting and damaging the metal of the brake drum housing.

Note . . .

The drum flange will not require machining as it will be freed when the drum wall has been removed.

- (5) Mark on the outside diameter of the new brake drum the centre line of two dia-

metrically opposed rivet holes. On the brake drum side of the wheel, mark out a centre line on the outer edge of the hub flange.

- (6) Heat the hub to a temperature of 100 deg. C by immersing it in boiling water. While the hub retains its heat, quickly dry it, and coat the exterior surface of the brake drum with a thin layer of pigmented varnish jointing compound (*Stores Ref. 33C/1264*).
- (7) With the nave unsupported, mount the hub on a press bed and position the brake drum so that the lines marked out on the hub and drum are in alignment.
- (8) Press the brake drum into the hub bore.
- (9) Apply a thin coat of pigmented varnish jointing compound to the eight newly-normalised rivets and rivet the drum to the hub. Wipe away the surplus compound.
- (10) Position the wheel in the lathe and set up as in (3). Machine the brake drum bore to $\frac{9.002}{9.000}$ in. dia. down to the radius in the corner at the bottom of the bore. The finished bore must be smooth and free from tool marks.
- (11) Check the machining, and with a 0.0015 in. feeler gauge, ascertain that the bearing cups have not come away from their abutment faces during the course of the repair.

Inspection

3. The repair must be to the satisfaction of the supervising inspector A.I.D., C.I.O./N.A.I., or C.I.O./A.I.S.

Painting

4. Restore the protection treatment where it has been damaged (Vol. 1, Sect. 1, Chap. 1).

Identification

5. After satisfactory completion of the repair, use $\frac{1}{8}$ in. metal stamps to mark "RP70" below the assembly issue number on the wheel. After marking the wheel paint the indentations with selenious acid solution.

(A.L.41, April 56)

RP 85
RECLAMATION OF STEEL BRAKE DRUMS

1. The brake drums listed in App. 2, Table 2 may be reclaimed by grinding if they are within the stated repair limits.
2. It is unimportant if the spigot bore diameter does not clean up all round provided that the bore diameter is not less than the dimension stated.
3. The reclaimed brake drum must conform with the limits given in Table 2.
4. The repair must be to the satisfaction of the Supervisory Inspector A.I.D., C.I.O./-N.A.I. or C.I.O./A.I.S.
5. After satisfactory completion of the repair use $\frac{1}{8}$ in. metal stamps to mark "RP 85" adjacent the issue number on the brake drum.

(A.L.35, Dec. 55)

RESTRICTED

F.S./1

P25448 571483/7448 2/56 1750 C&P Gp. 1

RP100 REPAIR TO WHEEL DRIVE BLOCK SCREW TAPPED HOLES

Introduction

1. This repair scheme deals with a method of repairing stripped threads on certain wheels by using wire thread inserts, and applies solely to the tapped holes for drive block screws. On some wheels it is not permissible to repair the inner drive block tapped holes by this method.

2. Only the threads in tapped holes which have been damaged are to be repaired.

3. A list of all the wheels which can be repaired by this scheme and relevant repair information is given in Table 1. The figures in Table 1 are to be substituted for the code letters in this scheme. For special tools required refer to Table 2.

Method of repair

- (1) Partially dismantle and degrease the wheel. It is not necessary to remove the bearings, the excluder, the oil seal housing, or similar hub assemblies to free the drive blocks, but it is essential to protect the hub bore against swarf and dirt by using suitable bungs.
- (2) Remove the outer and (if permissible) the inner drive block screws, using the ratchet and special screwdriver bit (Table 2). The bit of the screwdriver is held in position in the slot of the screw by a jack locally made up from a hexagon bolt cut to a suitable length, and a nut. The bolt is tightened sufficiently to enable the screwdriver bit to be held firmly in position. A sharp turn of the screwdriver will shear the Parker Kalon locking screw. Retain the drive block screws if they are not damaged.
- (3) Using a right-angle drill, drill out all the damaged drive block holes for the outer drive blocks "h" in. dia. x "c" in. deep to the drill point.
- (4) Similarly (if applicable) drill out all the

damaged drive block holes for the inner drive blocks "h" in. dia. x "j" in. deep to the drill point.

- (5) Tap all the drilled holes for the outer drive blocks to "e" in. dia. x "f" in. depth.
- (6) Tap all the holes for the inner drive blocks to "m" in. dia. x "n" in. depth.
- (7) Using the thread insert tool, fit Whitworth thread inserts "a" and "g" to the outer and (if permitted) the inner drive block holes respectively.
- (8) Each thread insert should be screwed in until it is half to one pitch below the surface.

Assembling

5. If the old drive block screws are used again, machine a new locking screw slot in a position diametrically opposite the one previously used. This new slot must be cut through the full thickness of the screw head, it must be of 0.067/0.057 in. width, and its base, 0.125/0.135 in. from the screw head centre. With the drive block screws, secure the drive blocks to the tenons with the special screwdriver bit and holder (Table 2). Using the locking screw slot in the screw head as a template, drill with a No. 51 (0.067 in. dia.) drill for the Parker Kalon screws and fit these screws to lock the drive blocks. Drive in the screws so that they are flush with the surface of the drive blocks.

Inspection

6. This repair must be to the satisfaction of the supervising inspector A.I.D., C.I.O./N.A.I., or C.I.O./A.I.S.

Identification

7. After satisfactory completion of the repair use $\frac{1}{8}$ in. metal stamps to mark "RP100" below the assembly issue number of the wheel. After marking the wheel, paint the indentations with selenious acid solution.

TABLE I
Thread insert, drill, and tapping data

Outer drive block holes						
Wheel Part No.	Hub Part No.	Thread insert (a)	dia. (b)	Drilled hole depth (c)	Drill letter (d)	Hole tapping dia. (e) depth (f)
AH.9729	AH.40174	$\frac{1}{4}$ in. Whit. thread \times 0-350 in. long (un-notched)	$\frac{0-269 \text{ in.}}{0-252 \text{ in.}}$	0-500 in.	G	0-3160 in. \times 20 T.P.I. (Whit. form thread) 0-375 in.
AH.9843	AH.40007	$\frac{1}{4}$ in. Whit. thread \times 0-400 in. long (un-notched)	$\frac{0-269 \text{ in.}}{0-252 \text{ in.}}$	0-562 in.	G	0-3160 in. \times 20 T.P.I. (Whit. form thread) 0-437 in.
AH.9811	AH.40457	$\frac{1}{4}$ in. Whit. thread \times 0-400 in. long (un-notched)	$\frac{0-269 \text{ in.}}{0-252 \text{ in.}}$	0-562 in.	G	0-3160 in. \times 20 T.P.I. (Whit. form thread) 0-437 in.
AH.9779	AH.40219	$\frac{1}{4}$ in. Whit. thread \times 0-400 in. long (un-notched)	$\frac{0-269 \text{ in.}}{0-252 \text{ in.}}$	0-670 in.	G	0-3160 in. \times 20 T.P.I. (Whit. form thread) 0-437 in.
Inner drive block holes						
Wheel Part No.	Hub Part No.	Thread insert (g)	dia. (h)	Drilled hole depth (i)	Drill letter (k)	Hole tapping dia. (m) depth (n)
AH.9729	AH.40174	$\frac{1}{4}$ in. Whit. thread \times 0-350 in. long (un-notched)	$\frac{0-269 \text{ in.}}{0-252 \text{ in.}}$	0-500 in.	G	0-3160 in. \times 20 T.P.I. (Whit. form thread) 0-375 in.
AH.9843	AH.40007	Not permissible				
AH.9811	AH.40457	$\frac{5}{16}$ in. Whit. thread \times 0-340 in. long (un-notched)	$\frac{0-3326 \text{ in.}}{0-3145 \text{ in.}}$	0-500 in.	P	0-3857 in. \times 18 T.P.I. (Whit. form thread) 0-375 in.
AH.9779	AH.40219	$\frac{5}{16}$ in. Whit. thread \times 0-400 in. long (un-notched)	$\frac{0-3326 \text{ in.}}{0-3145 \text{ in.}}$	0-625 in.	P	0-3857 in. \times 18 T.P.I. (Whit. form thread) 0-437 in.

(A.L.68, May 58)

TABLE 2
Special tools

The following is a list of special tools needed to carry out the repair scheme RP100 on individual wheels:—

Wheel Part No.	Tool Part No.	Description
AH.9729	AO.61785	Bung
	AO.61786	Bung
	AM.30991	Drill jig (outer drive block holes)
	AM.30998	Drill jig (inner drive block holes)
	AM.30992	Tapping jig (outer drive block holes)
	AM.30999	Tapping jig (inner drive block holes)
AH.9343	AO.61787	Bungs (2)
	A.9130	Drill jig (outer drive block holes)
	A.9131	Tapping jig (outer drive block holes)
AH.9811	AO.61787	Bungs (2)
	A.21053	Drill jig (outer drive block holes)
	A.21054	Drill jig (inner drive block holes)
	A.21055	Tapping jig (outer drive block holes)
	A.21056	Tapping jig (inner drive block holes)
AH.9779	AO.61787	Bungs (2)
	A.21058	Drill jig (outer drive block holes)
	A.21059	Drill jig (inner drive block holes)
	A.21060	Tapping jig (outer drive block holes)
	A.21061	Tapping jig (inner drive block holes)
	MSD.206	Screwdriver bit ($\frac{3}{8}$ in. drive)
	RPS.206	Ratchet handle ($\frac{3}{8}$ in. drive)
	AO.49801	Holder for screwdriver bit
All wheels	—	Jack (made up locally from a hexagon bolt, cut to a suitable length, and a nut).

RESTRICTED

TABLE 5
Details of liners for wheel-bearing housings
(dimensions in inches)

Part No.	Material Spec.	A (dia.)	B (dia.)	C	D (dia.)	E	S (chamfer)	R ₁ (rad.)	R ₂ (rad.)	Treatment
RP42/SA	Commercial mild steel	5.091	4.710	1.592	4.255	1.192	0.010	0.075	0.108	Cadmium plate to D.T.D.904
		5.090 (5.092 max. after plating)	4.700	1.562	4.245	1.182	0.005 ×45 deg.	0.045	0.078	
RP42/SB	Commercial mild steel	4.461	4.067	1.195	3.755	0.875	0.010	0.075	0.108	Cadmium plate to D.T.D.904
		4.460 (4.462 max. after plating)	4.057	1.165	3.745	0.865 ×45 deg.	0.005 ×45 deg.	0.045	0.078	

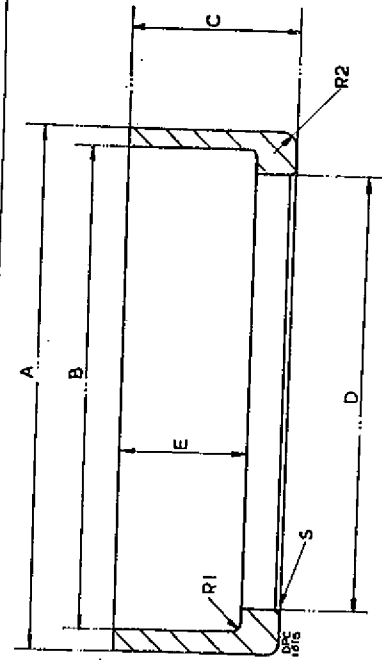

RESTRICTED

RP.106

REPAIR OF BEARING HOUSING WHEEL

AH.9779, AH.51337

Scheme

1. If the existing liner in the loose flange side of the wheel has become loose, the bearing housing on this side of the wheel may be relined. When a 1st stage repair cannot be carried out, a 2nd stage repair may be undertaken.

2. The following items are required

Part No.	Description
RP.33/3A	Bearing liner (1st stage repair)
	or
RP.33/3B	Bearing liner (2nd stage repair)

Araldite MY.753 and Hardener HY.951
(Sect. 1, Chap. 1, App. 3, Process 2).

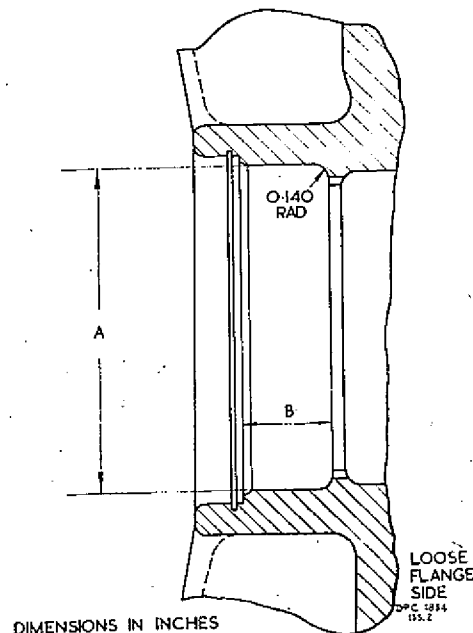

Fig. 1. Machining the housing

Selenious acid solution; make from 2 oz. selenious acid crystals dissolved in one pint of water.

Method of repair

3. (1) Dismantle the wheel in accordance with Vol. 1, Book 1, Sect. 1, Chap. 1. Extract the loose liner, degrease the hub and, if necessary, remove the paint.

(2) Mount the wheel in a lathe so that the chuck jaws locate on the rim at the fixed flange side of the wheel. The hub must run true in both the vertical and horizontal planes. To check for truth apply a d.t.i. to the hub bore. The maximum permitted variation is 0.002 in.

(3) Machine the hub at the locations shown in fig. 1. The values of A and B are as follows:—

	A dia. (in.)	B length (in.)
1st stage repair	6.531/6.530	1.790/1.780
2nd stage repair	6.561/6.560	1.805/1.795

(4) Clean the machined surfaces and apply selenious acid solution or if possible re-chromate.

(5) Coat the mating surfaces of the hub bore with Araldite and Hardener. Freeze the relevant bearing liner to minus 60 deg. C and press it fully into the hub. There must be no gap between the inner end of the liner and the abutment face of the housing; check this with a 0.0015 in. feeler gauge. Allow the hub assembly to normalize for at least one hour before machining.

(6) Set up the wheel in a lathe as detailed in sub-para. (2) and machine the bearing liner to the details given in fig. 2. Drill two extractor slots at the loose-flange end of the wheel so that the cutter will ultimately engage the existing

RESTRICTED

R.P.134

REPAIR TO INNER DRIVE BLOCK TENONS ON A WHEEL HUB

Introduction

1. This repair scheme deals with a method of repairing the inner drive block tenons of hub, Part No. AH.40455 which belongs to the main wheel, Part No. AH.50207 and describes the fitting of new inner drive blocks. Only inner drive block tenons which have been damaged need be repaired.

2. For details of special tools refer to Table 1.

Method of repair

3. (1) Dismantle the wheel and degrease the hub.

(2) Remove the inner drive block screws by using the ratchet handle and screwdriver bit referred to in Table 1. The bit of the screwdriver is held in position in the slot of the screw by a jack locally made up from a hexagon bolt cut to a suitable length and a nut. The bolt is tightened sufficiently to enable the screwdriver bit to be held firmly in position. A sharp turn of the screwdriver will shear the Parker Kalon locking screw. Retain the drive block screws if they are not damaged.

(3) Set up the hub in a slotting machine by locating on its 4.121/4.122 in. dia. bore and 0.469 in. slot. Use the slotting fixture, Part No. A.5909 and the location spigot, Part No. AM.19480 (Table 1). Pick up from one of the existing tenons and machine the 12 tenons to a width of 0.395/0.400 in. as shown in RP.134/2 (fig. 2).

(4) If the old drive block screws are used again, machine a

new locking screw slot in a position diametrically opposite the one previously used. This new slot must be cut through the full thickness of the screwhead, must be of 0.073/0.088 in. width and its base 0.125/0.135 in. from the screw head centre.

(5) With the drive block screws secure the drive blocks, Part No. RP.134/1 to the tenons with the special screwdriver bit and holder (Table 1). Using the locking screw slot in the head as a template, drill with a No. 51 (0.067) drill for the Parker Kalon screws and fit

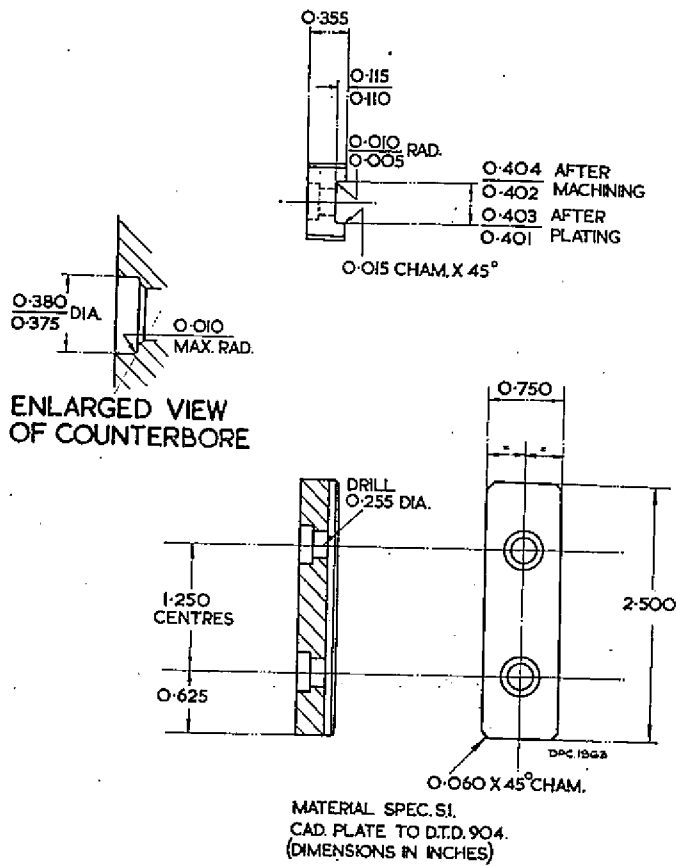

INNER DRIVE BLOCK RP.134/1
Fig. 1. Details of inner drive block

F.S./1

RESTRICTED

(A.L.59, Aug. 57)

ub is to be
nber before

wheel in
Sect. 1.

cordance
p. 1 and

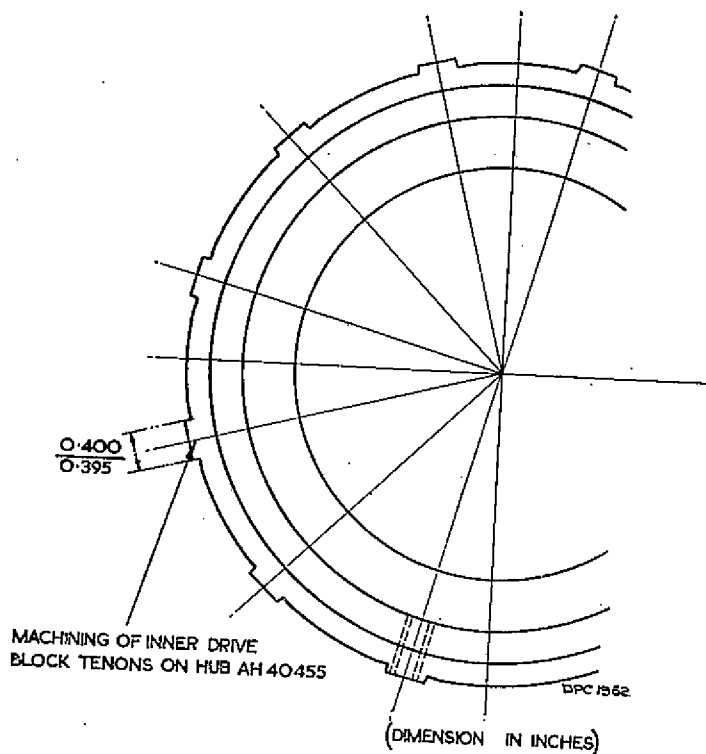

RP 134/2

Fig. 2. Machining of inner drive block tenons

these screws to lock the drive block screws (RP.134/3, fig. 3).

Inspection

4. Inspection must be to the satisfaction of the supervising inspector A.I.D., C.I.O./N.A.I. or C.I.O./A.I.S.

New parts

6. The undermentioned new parts are required to embody this repair:—

Ref. No.	Description	No. off
RP.134/1	Drive block	As required
No. 0 × 1/4 in. long	Screw, Parker Kalon, (headless, type "U")	As required
AHO.38001	Screw (inner drive block)	As required

TABLE I
Special tools

The following is a list of special tools needed to carry out the repair scheme RP.134:—

Part No.	Description	Part No.	Description
MSD.206	Screwdriver bit (3/8 drive)	AO.68115	Gap gauge (0.395/0.400 in.)
RPS.206	Ratchet handle (3/8 drive)	AO.49801	Holder for screwdriver bit
A.5909	Slotting fixture	—	Jack (made up locally from a hexagon bolt cut to a suitable length, and a nut)
AM.19480	Location spigot for fixture		
AM.6246	Tool holder		

RESTRICTED

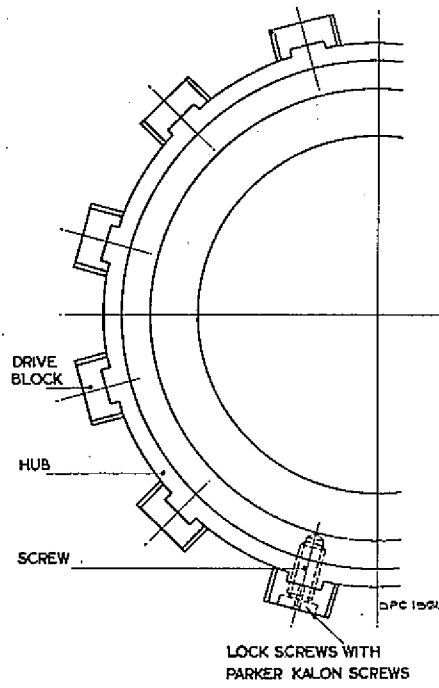

RP134/3

Fig. 3. Details of locking of drive block screws

the
mark
iber
int
on.

RPI56

REPAIR TO WHEEL DRIVE BLOCK SCREW TAPPED HOLES

Introduction

1. This repair scheme introduces wire thread inserts in the inner drive block screw holes of main wheel Part No. AH.50207 (hub, Part No. AH.40455). It may also be used for the repair of damaged inner drive block screw holes. For the sake of clarity, the two parallel sets of inner drive block screw holes are referred to as A and B in fig. 1. For the special tools required refer to Table 1.

Method of repair

2. (1) It is not necessary to dismantle the wheel but the hub bore must be adequately protected by bungs to prevent the ingress of dirt and swarf.
- (2) Remove the inner drive block screws by using the ratchet handle and special screwdriver bit (Table 1). The bit of the screwdriver is held in position in the slot of the screw by a jack locally made from a hexagon bolt cut to a suitable length, and a nut. The bolt is tightened sufficiently to enable the screwdriver bit to be held firmly in

position. A sharp turn of the screwdriver will shear the Parker Kalon locking screw. Retain the drive block screws if they are not damaged.

- (3) Remove the inner drive blocks.
- (4) Before drilling out the inner drive block screw holes in the hub, it must be emphasised that:—
 - (a) The inner drive block screw holes "A" are in contact with the steel bearing liner. Care should therefore, be exercised, when drilling, to ensure that the drillings do not enter the steel bearing liner.
- (5) With the flat-end letter G drill, drill out the inner drive block screw holes "A" to 0.269/0.252 in. dia. until the steel sleeve is contacted.
- (6) With a flat-end letter G drill, drill out the inner drive block screw holes "B" to 0.269/0.252 in. dia. \times 0.687 in. deep to drill point.

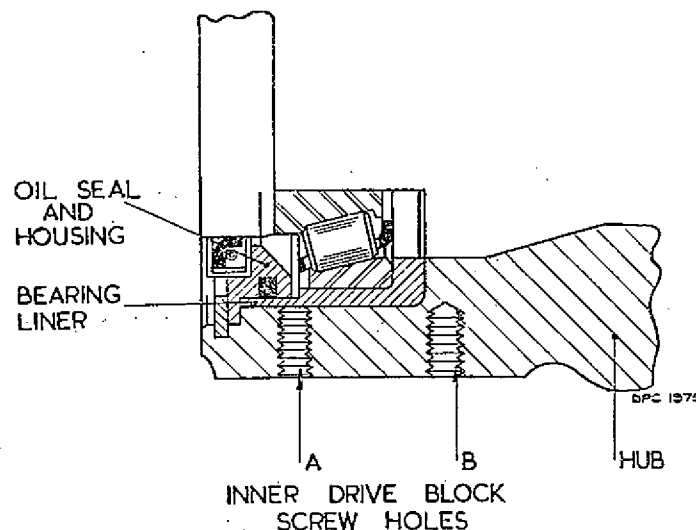

Fig. 1. Positions of drive block screw holes

- (7) Tap the inner drive block screw holes "A", 0.3160 in. dia. \times 20 t.p.i. Whit. form thread as far as the steel sleeve, to suit the $\frac{1}{4}$ in. dia. Whit. thread insert. Ensure a full thread when tapping. Using the thread insert tool, fit $\frac{1}{4}$ in. Whit. thread inserts \times 0.525 in. long (unnotched). Each thread insert should be screwed in until it is half to one pitch below the surface.
- (8) Tap the inner drive block screw holes "B" 0.3160 in. dia. \times 20 t.p.i. Whit. form thread \times 0.562 in. deep to suit $\frac{1}{4}$ in. Whit. thread

(A.L.57, May 57)

- inserts. Ensure a full thread when tapping. Using the thread insert tool, fit $\frac{1}{4}$ in. Whit. thread inserts $\times 0.525$ in. long (unnotched) to these holes. Each thread insert should be screwed in until it is half to one pitch below the surface.
- (9) If the old drive block screws are used again, machine a new locking screw slot in a position diametrically opposite the one previously used. This new slot must be cut through the full thickness of the screw head, must be of 0.067/0.057 in. width, and its base 0.125/0.135 in. from the screw head centre.
- (10) With the drive block screws, secure the drive block to the tenons with the special screwdriver bit and holder (Table 1). Using the locking screw slot in the head of the screw as a template, drill with a No. 51 (0.067 in. dia.) drill for the Parker Kalon screws and fit the

screws to lock the drive blocks. Drive in the screws so that they are flush with the surface of the drive blocks.

Inspection

3. The repair must be to the satisfaction of the supervising inspector A.I.D., C.I.O./N.A.I. or C.I.O./A.I.S.

Identification

4. After satisfactory completion of the repair "RP156" is to be stamped adjacent to the Assembly Issue Number of the wheel with $\frac{1}{8}$ in. metal stamps. Paint the indentations with selenious acid solution made from 2 oz. selenious acid crystals dissolved in one pint of water.

New parts

5. The following new parts are needed to make this repair:—

Ref. No.	Description	No. off
$\frac{1}{4}$ in. Whit. $\times 0.525$ in. long (unnotched)	Wire thread insert	24
No. 0 $\times \frac{1}{4}$ in. long AHO.38000	Screw, Parker Kalon (headless type "U") Drive block	24 12
AHO.38001	Screw, drive block	24

RESTRICTED

TABLE I
Special tools

The following is a list of special tools needed to carry out this repair scheme:—

Tool Part No.	Description
A.21466	Drill jig
A.21467	Tapping jig
—	Right-angle drill (standard)
—	Tap (Whit. form) 0.3160 in. dia. × 20 t.p.i. threads
—	Screw plug gauge for 0.3160 in. dia. × 20 t.p.i. threads
AO.70285	Thread insert tool
AO.61786	Bung for 2.9998/2.9993 bore
AO.61785	Bung for 2.4998/2.4993 bore
<i>Tools for drive block screws</i>	
MSD.206	Screwdriver bit ($\frac{3}{8}$ in. drive)
RPS.206	Ratchet handle ($\frac{3}{8}$ in. drive)
AO.49801	Holder for screwdriver bit
—	Jack (made locally from a hexagon bolt cut to a suitable length, and a nut).

RP.167

REPAIR TO HOUSING FOR WHEEL BEARING

Requirements

Lathe:—Herbert No. 21 combination or its equivalent.

Press tools:—

Description	Part No.
Mandrel and base	AO.45833
Pressing in sleeve	AO.75929
Collars (2)	AO.50393
Packing collar	AO.101302

New Part:—Liner, Part No. RP.167/1B. This part is to be provided under Unit arrangements.

Selenious acid solution:—2 oz. selenious acid crystals dissolved in one pint of water.

WARNING

Selenious acid crystals or solution must not be allowed to come into contact with the skin.

Introduction

1. Due to various causes, the housing for the wheel bearing at the loose flange side of the wheel may become so enlarged that the outer track of the bearing is loose in the housing. Bearing creep in the housing is permissible providing the bearing is not loose in the housing. When this condition arises, the affected housing must be enlarged and a dural liner fitted to restore the housing to its original dimension.

Method of repair

- (1) Dismantle and degrease the wheel.
- (2) Remove the paint as described in Vol. 1, Book 1, Sect. 1, Chap. 1.

- (3) Mount the wheel hub in the lathe, holding the hub at the flanged end in the turning fixture, Part No. A.9046 and locating in the 18.943/18.940 in. dia. The wheel must then be set up to run true in both the vertical and horizontal planes. To check for truth, apply a dial test indicator to the hub of the bearing housing, the maximum D.T.I. variation permitted is 0.002 in.
- (4) Machine the bearing housing at the loose flange end of the wheel to the dimensions given in RP.167/1A (fig. 1). Check the bore diameter using a standard dial bore gauge which has been set with the setting ring, Part No. AO.56938 and the depth with the gauge, Part No. AO.75928. Check the 6.596/6.593 in. dia. bore using the pin gauges, Part No. AO.72146 and AO.72147, and use the profile gauge, Part No. AO.72145 to check the 0.635 in. depth and the 0.125 in. radius.
- (5) Clean the machined surfaces and repair the chromate film (A.P.2656A, Vol. 1, Sect. 5, Chap. 2).
- (6) Heat the hub to a temperature of

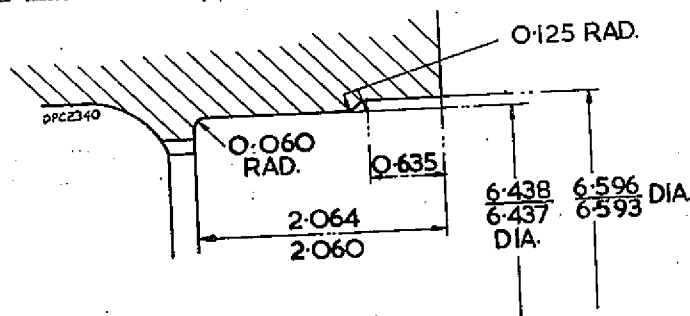

(DIMENSIONS IN INCHES)
RP167/1A

Fig. 1. Machining of bearing housing

(A.L.63, Jan. 58)

RESTRICTED

100 deg. C by immersing it in boiling water. While the hub retains its heat, quickly dry it and coat the exterior surface of the liner, Part No. RP.167/1B (fig. 2) with pigmented varnish jointing compound (Stores Ref. 33C/1264).

- (7) Position the mandrel and base and one collar on the press, place the wheel hub over the mandrel, and locate the liner on the hub bore.
- (8) Engage the liner with the pressing in sleeve, then position the other collar and packing collar over the mandrel.
- (9) Press in the bearing liner. There must be no gap between the flange of the liner and the abutment face of the housing; check this using a 0.0015 in. feeler gauge.
- (10) When the wheel is cool, set it up in a lathe as in (3) and machine the bearing liner at the loose flange side to the dimensions given in RP.167/1C (fig. 3).

Check the 6.244/6.243 in. bore dia. using a standard dial bore gauge which has been set with the setting ring, Part No. AO.61890, and using the plug gauge, Part No. AO.55631 check the 6.378/6.375 in. dia. Use also for checking, the following:—

Part No.	Description	Measurement to be checked
AO.59089	Slip gauge	0.063/0.060 in.
AO.75932	Gap gauge	7.088/7.082 in.
AO.61755	Gauging plate (used with the depth gauge, AO.51942)	1.530 in.
AO.51942	Depth gauge	—
AO.60478	Gauging plate (used with slip gauge AO.35288)	0.183/0.180 in.
AO.35288	Slip gauge	—

(11) Clean the machined surface of the liner.

(12) Set the wheel up on the table of a vertical miller and using drill jig, Part No. AM.14916 and cutter Part No. AO.57605, mill two bearing removal slots 0.375 in. radius in the bearing bore, and align them with the existing slots in the hub at the loose flange end of the wheel.

(13) Carefully remove all burrs from the slots and check that the slots conform to drawing requirements.

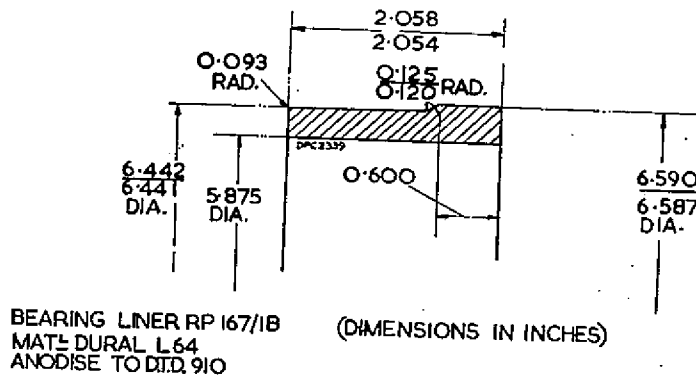

Fig. 2. Details of bearing liner

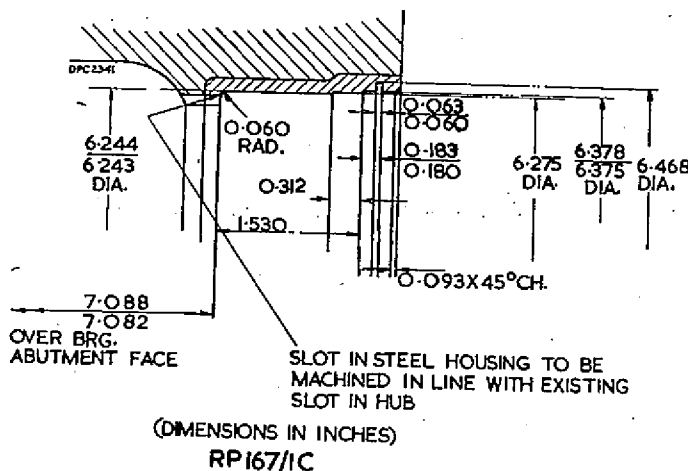

Fig. 3. Machining of fitted liner

Inspection

3. The repair must be to the satisfaction of the supervising inspector A.I.D., C.I.O./N.A.I. or C.I.O./A.I.S.

Painting

4. Repaint the hub as described in Vol. 1, Book 1, Sect. 1, Chap. 1.

Identification

5. After satisfactory completion of the repair, use $\frac{1}{8}$ in. metal stamps to mark "RP.167" immediately below the assembly Issue No. on the wheel. After marking the wheel, paint the indentations with the selenious acid solution.

RESTRICTED

RP.168 REPAIR SCHEME TO MAIN WHEELS FITTED WITH BOLTED-IN STEEL BEARING SLEEVES

Requirements

Selenious acid solution:—

2 oz. selenious acid crystals dissolved in one pint of water

Adhesive, synthetic resin, No. 103 (Stores Ref. 33C/1371) and Hardener 951 (Stores Ref. 33C/1372)

WARNING

Selenious acid crystals or solution must not be allowed to come into contact with the skin.

Introduction

1. This repair scheme may be used for the repair of all main wheels fitted with bolted-in steel bearing sleeves.

Nature of repair

2. Where examination shows that:—

- (1) A gap exists between the sleeve and the abutment face of the housing
- or
- (2) The peening lock of the sleeve bolt securing nuts is broken; the wheels must be withdrawn from service and reclaimed as detailed below.

Method of repair

3. The wheels must be partially dismantled to ensure that the steel bearing sleeve bolts may be withdrawn from the sleeves. The amount of dismantling to achieve this depends upon the type of wheel. In some instances it will not be necessary to remove both or either bearings. Repair a typical wheel as follows:—

- (1) Remove the circlip from the loose flange side of the wheel and withdraw the excluder, the locating ring, and the bearing inner race.
- (2) Remove the circlip from the opposite side of the wheel and withdraw the felt housing complete with the felt seal(s) and the bearing inner race.

- (3) Press out the bearing outer race using the relevant tool.
- (4) Unscrew the bearing sleeve retaining nuts and withdraw the bolts. Discard the bolts and nuts.
- (5) Apply a thick coating of Adhesive, synthetic resin and Hardener 951 to the gap between the steel bearing flange and the hub.
- (6) Position the wheel on the press. Support the wheel and keep the rim clear of the press bed by placing a parallel block between the bed of the press and the adjacent wheel nave. The block must be in full contact with the centre boss of the wheel and in no circumstances must it touch the spokes or outer flange. Failure to comply with this instruction may result in strain to the wheel.
- (7) Press in the bearing sleeve to ensure positive abutment with the hub. There must be no gap between the steel sleeve bearing flange and the hub. Check this using a 0.0015 in. feeler gauge.
- (8) Select new bolts and nuts appropriate to the wheel, coat the bolt shank with pigmented varnish jointing compound (Stores Ref. 33C/1264) and insert them through the sleeves and the hub.
- (9) Lubricate the bolt threads with the bearing grease and secure them with the nuts. Tighten the nuts evenly and in diametrical sequence, to the torque loading quoted in Table 1.
- (10) Securely lock the nuts by peening a positive amount of bolt metal into each end of the slot provided in the nut or by peening the metal at four equidistant places over the outer face of the nut.

(A.L.56, May 57)

Note . . .

The method of peening is dependent upon the type of nut used.

- (11) Remove the surplus grease and re-assemble the wheel.

Inspection

4. The repair must be to the satisfaction of the supervising inspector A.I.D., C.I.O./N.A.I., or C.I.O./A.I.S.

Identification

5. After satisfactory completion of the repair use $\frac{1}{8}$ in. metal stamps to mark "RP.168" below the assembly issue number of the wheel. Paint the indentations with selenious acid solution.

TABLE I
Torque loadings for bearing sleeve bolts
(55 ton per sq. in. tensile strength)

Size of bolt (in.)	Torque to be applied, when tightening bolts* (lb. ft.)
$\frac{5}{16}$ B.S.F.	11
$\frac{3}{8}$ B.S.F.	17
$\frac{3}{16}$ B.S.F.	25
$\frac{1}{2}$ B.S.F.	40
$\frac{9}{16}$ B.S.F.	55
$\frac{5}{8}$ B.S.F.	70
$\frac{11}{16}$ B.S.F.	90

* All bolt threads must be greased before torque loading is applied.

RESTRICTED.

RP171

REPAIR TO HOUSINGS FOR WHEEL BEARINGS

Requirements

Lathe:—Herbert No. 9 combination or its equivalent

Press tools:—

- Mandrel and base
- Pressing in sleeve
- Pressing in sleeve
- Collar
- Packing collar

- Part No.*
- AO.42699
- AO.102884
- AO.42468
- AO.50393
- AO.101132

New Parts:—Liner, Part No. RP171/1A and shim, Part No. RP171/1B. These parts are to be provided under Unit arrangements. Details of the liner and shim are given in Table 1 and Table 4 respectively.

Selenious acid solutions:—2 oz. selenious acid crystals dissolved in one pint of water.

WARNING

Selenious acid crystals or solution must not be allowed to come into contact with the skin.

Introduction

1. Due to various causes the housing for the wheel bearing at the fixed flange end of the wheel may become so enlarged that the outer track is loose in the housing. When this condition arises the housing must be enlarged and a liner fitted to restore the housing to its original dimensions. Bearing creep in the housing is permissible provided the bearing is not loose in the housing.

2. Similarly, the housing for the wheel bearing at the loose flange end of the wheel may become so enlarged that the outer track is loose in the housing. When this condition arises, the housing must be enlarged and a shim fitted to restore the housing to its original dimensions.

Method of repair

3. (1) Dismantle and degrease the wheel.
- (2) Remove the paint as described in Vol. 1, Sect. 1, Chap. 1.

(3) Mount the wheel hub in the lathe on the face plate by locating from the 3-9350/3-9345 in. bore at the fixed flange end of the hub; use the locating spigot, Part No. AO.33250 and the clamps, Part No. AO.24699. The wheel must then be set up to run true in both the vertical and horizontal planes. To check for truth, apply a dial test indicator to the hub of the bearing housing, the maximum D.T.I. variation permitted is 0.002 in.

(4) Machine the bearing housing at the loose flange end of the wheel to the dimensions given in RP.171/1 (*fig. 1*). Check the bore diameter with a standard dial bore gauge which has been set with the setting ring, Part No. AO.73072.

(A.L.57, May 57)

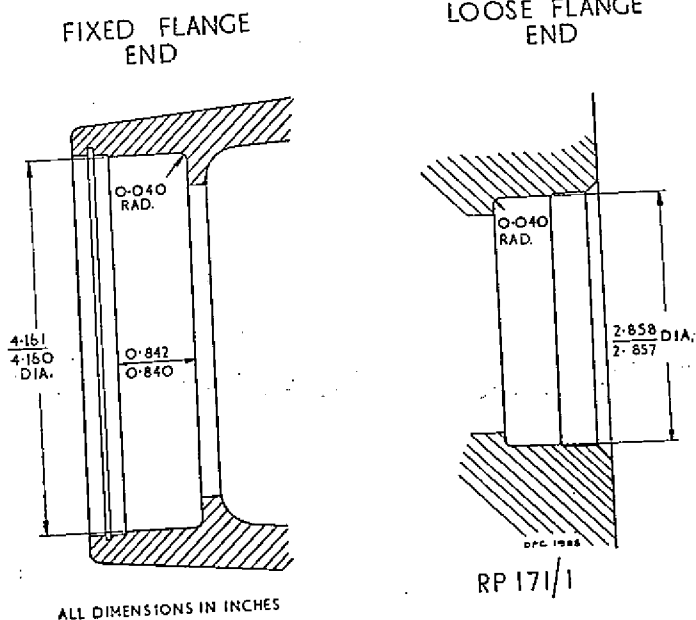

Fig. 1. Dimensions for machining bearing housings

F.S./1

RESTRICTED

- (5) Reverse the wheel in the lathe and adjust the chuck jaws to grip the parallel tyre seat diameter. Set up as described in (3) and machine the bearing housing at the fixed flange end to the dimensions given in RP.171/1. Check the bore diameter with a standard dial bore gauge which has been set with the setting ring, Part No. AO.73073. Check the depth with depth gauge, Part No. AO.73074.
- (6) Clean the machined surfaces and repair the chrome film (A.P.2656A, Vol. 1, Sect. 5, Chap. 2).
- (7) Heat the hub to a temperature of 100 deg. C by immersing it in boiling water. While the hub retains its heat, quickly dry it and coat the exterior surface of the liner, Part No. RP.171/1A with pigmented varnish jointing compound (Stores Ref. 33C/1264).
- (8) Position the mandrel and base on the press, place the wheel hub over the mandrel and locate the liner on the hub bore.
- (9) Engage the liner with the pressing in sleeve, then position the collar and packing collar over the mandrel.
- (10) Press in the bearing liner. There must be no gap between the flange of the liner and the abutment face of the housing; check this using a 0.0015 in. feeler gauge.
- (11) When the wheel is cool, set it up in a lathe as in (5) and machine the bearing liner at the fixed flange end to the dimensions given in RP.171/2 (fig. 2). Check the bore diameter with a standard dial bore gauge which has been set with the setting ring, Part No. AO.54215. Check the depth with depth gauge, Part No. AO.33258 and the 3.660/3.655 gap with gap gauge, Part No. AO.33537.
- (12) Remove the wheel from the lathe and heat the hub to a temperature of 100 deg. C by immersing it in boiling water. Position the bung, Part No. AO.102885

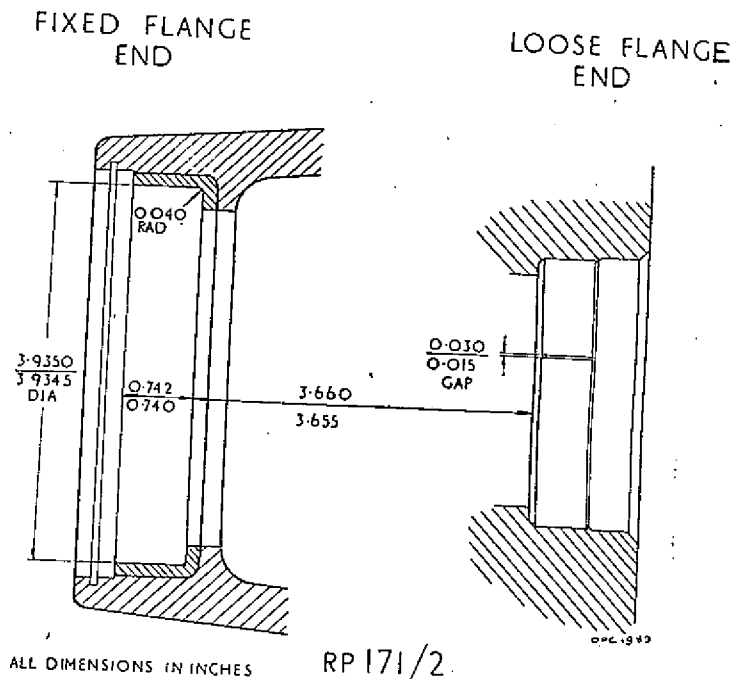

Fig. 2. Dimensions for machining fitted liner and shim

- (13) Apply a thin coat of adhesive, synthetic resin, No. 103 (Stores Ref. 33C/1371) with Hardener, No. 951 (Stores Ref. 33C/1372) to the machined surface of the bearing housing at the loose flange side. Insert the shim RP.171/1B into the housing and ensure the gap is 0.015/0.030 in. as shown in RP.171/2 (fig. 2).
- (14) Position the mandrel and base, Part No. AO.42699 on the press, place the wheel hub over the mandrel and locate the bearing over the hub bore.
- (15) Engage the bearing with the pressing in sleeve, Part No. AO.42468, then position the collar Part No. AO.50393 over the mandrel. While the hub still retains its temperature of 100 deg. C press the bearing firmly into position and ensure that the shim does not move during this operation.

Inspection

4. The repair must be to the satisfaction of the supervising inspector A.I.D., C.I.O./N.A.I. or C.I.O./A.I.S.

RESTRICTED

Painting

5. Repaint the hub as described in Vol. 1, Sect. 1, Chap. 1.

Identification

6. After satisfactory completion of the repair

use $\frac{1}{8}$ in. metal stamps to mark "RP.171" below the assembly issue number on the wheel. After marking the wheel, paint the indentations with selenious acid solution.

464
62

RP.182

RECLAIMING MAXARET TRACK ON WHEEL, Part No. AH.50122 (HUB, Part No. AH.40460)

Introduction

1. To reclaim wheel hubs on which the Maxaret track has been damaged.

Method of repair

2. (1) Dismantle and degrease the wheel.
- (2) Remove the paint as described in Vol. 1, Sect. 1, Chap. 1.
- (3) Mount the wheel hub in a lathe to locate on the parallel tyre seat diameter. The wheel must then be set up to run true in both the vertical and horizontal planes. To check for truth, apply a dial test indicator to the hub of the bearing housing; the maximum D.T.I. variation permitted is 0.002 in.
- (4) Machine the hub at the flanged end of the wheel to the dimensions given in RP.182/1 (fig. 1). Check with a pin gauge the $\frac{19.255}{19.250}$ in. dia., with a depth gauge the 0.161 in. depth, and with a gap gauge the 0.770 in. gap.

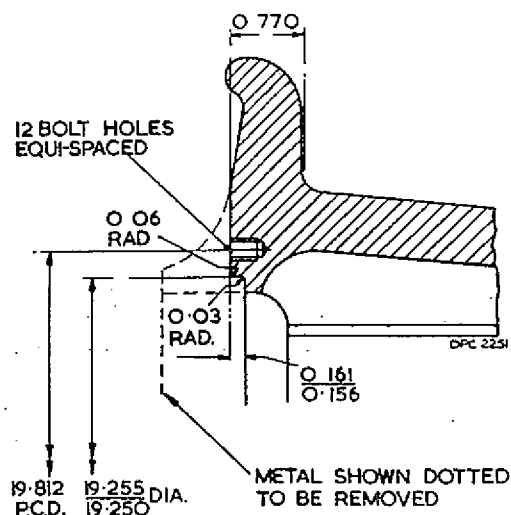

RP. 182/1
(DIMENSIONS IN INCHES)

Fig. 1. Dimensions for machining hub

- (5) Using a drill jig with slip bushes, drill 12 equi-spaced holes on the 19.812 in. P.D.C. to $\frac{0.1991}{0.1870}$ dia. (No. 10 drill) \times 0.375 in. deep. The radial position of the holes is not important.
- (6) Tap the 12 holes 0.2252 in. dia. \times 31.3 T.P.I. \times 0.312 in. deep to suit 2 B.A. thread inserts.
- (7) Using the thread insert tool, Part No. AO.70287, fit the twelve thread inserts, Part No. AS.4601/14.
- (8) Coat the machined surface of the hub and the mating face of the Maxaret track, Part No. RP.182/2, manufacturing details of which are given in fig. 2, with pigmented varnish jointing compound (Stores Ref. 33C/885), and secure the Maxaret track to the hub with the 12 bolts and tab washers (fig. 3).

Inspection

3. The repair must be to the satisfaction of the supervising inspector A.I.D., C.I.O./N.A.I. or C.I.O./A.I.S.

Identification

4. After satisfactory completion of the repair, use $\frac{1}{8}$ in. metal stamps to mark "RP.182" below the assembly issue number on the wheel. After marking the wheel, paint the indentations with selenious acid solutions made from 2 oz. selenious acid crystals dissolved in one pint of water.

Painting

5. Repaint the hub as described in Vol. 1, Sect. 1, Chap. 1.

New parts

6. The undermentioned new parts are required to embody this repair:—

Part No.	Description	No. off
AS.4601/14	Wire thread insert	12
BS.SP.41/C	Tab washer	12
AHO.38297	Bolt	12
RP.182/2	Track	1

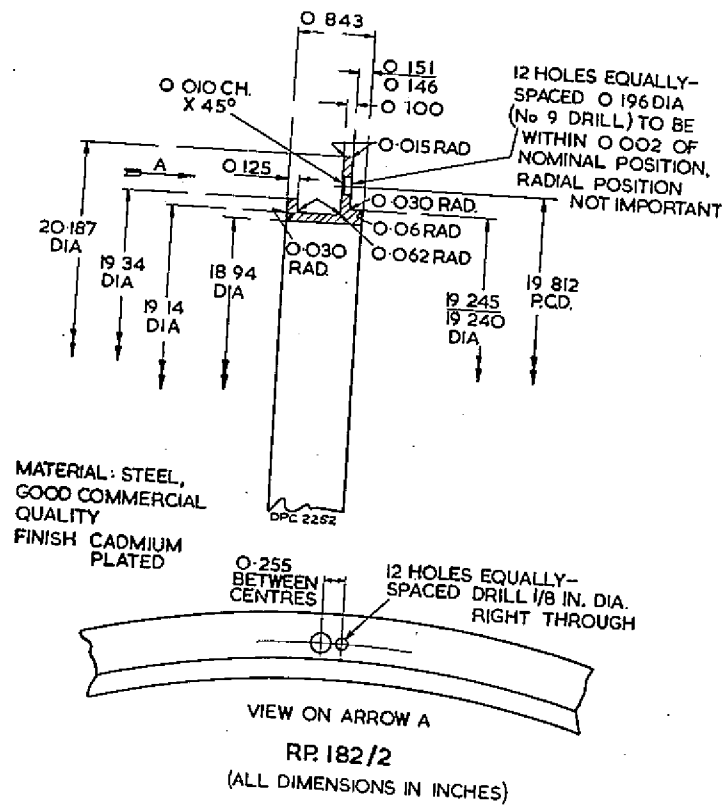

Fig. 2. Manufacturing details of Maxaret track

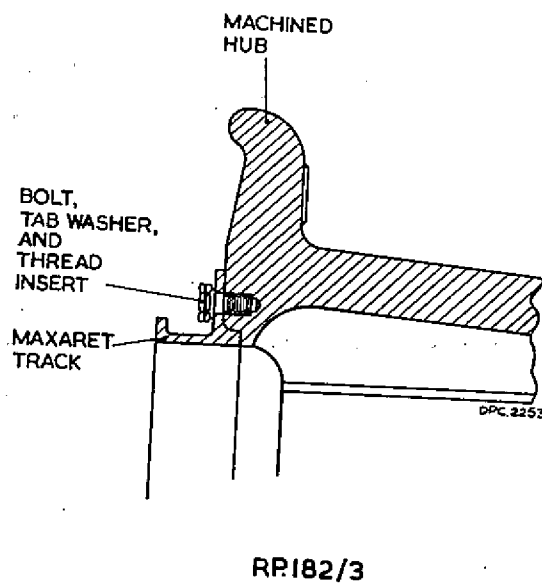

Fig. 3. Maxaret track assembled to wheel

RESTRICTED

RP.184

REPAIR TO MAXARET TRACK WHEEL, Part No. AH.50611 (HUB, Part No. AH.40766)

Nature of repair

1. To remove score marks or corrosion from the Maxaret track by machining it to an increased diameter.

Method of repair

2. (1) Dismantle and degrease the wheel.
- (2) Mount the wheel in a lathe so that the chuck jaws locate around the parallel tyre seat diameter. The wheel must then be set up so that the hub runs true in both the vertical and horizontal planes. To check for truth, apply a dial test indicator to the nave. The maximum D.T.I. variation permitted is 0.002 in.
- (3) Machine the Maxaret track to the dimensions given in RP.184/1 (fig. 1). Ensure the depth of turning does not exceed 1.230 in., and blend the radius as shown.
- (4) Degrease the freshly-machined surface, and in accordance with D.T.D.911, paint it with selenious acid solution made from 2 oz. selenious acid crystals dissolved in one pint of water.
- (5) Paint the machined track with primers and aluminium cellulose enamel as detailed in Vol. 1, Book 1, Sect. 1, Chap. 1.

Inspection

3. The repair must be to the satisfaction of the supervising inspector A.I.D., C.I.O./N.A.I. or C.I.O./A.I.S.

Identification

4. After satisfactory completion of the repair, use $\frac{1}{8}$ in. metal stamps to mark "RP.184" below the assembly issue number of the wheel. Paint the indentations with selenious acid solution.

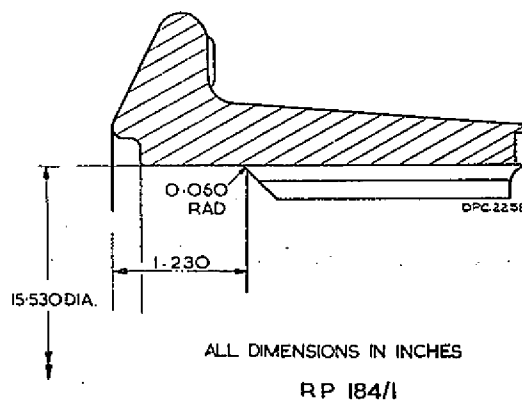

Fig. 1. Dimensions of Maxaret track

RP.187 REPAIRING THE MAXARET TRACK MAIN WHEEL, AH.9982 (HUB, AH.40304)

Requirements

New Parts.—Ring, Part No. RP.187/2, 1 off. Rivet, Part No. AS.455/411, 10 off. These parts are to be provided under Unit arrangements.

Selenious acid solution.—2 oz. selenious acid crystals dissolved in one pint of water.

WARNING

Selenious acid crystals or solution must not be allowed to come into contact with the skin.

Introduction

1. This repair scheme details a method of repairing these wheels by riveting on a steel ring after removal of the existing Maxaret track.

Method of repair

2. (1) Dismantle and degrease the wheel.
- (2) Mount the hub in a lathe with the chuck jaws engaging the parallel seat diameter. It must then be set up so that the hub runs true in both the vertical and horizontal planes. To check for truth, apply a dial test indicator to the hub. The maximum permitted D.T.I. variation is 0.002 in.
- (3) Machine the face of the flange to the dimensions given in RP.187/1 (fig. 1).
- (4) Clean the machined surface and repair the chromate film (A.P.2656A, Vol. 1, Sect. 5, Chap. 2).
- (5) Refer to RP.187/3 (fig. 3). Using the steel ring, Part No. RP.187/2 (fig. 2) as a jig, drill 10 holes 0.1285 in. dia. using a No. 30 drill through the hub flange. Counter-sink the holes to 0.250 in. dia. × 90 deg.
- (6) Rivet the ring securely to the hub using ten $\frac{1}{8}$ in. dia. mild steel rivets, 0.687 in.

long (AS.455/411). After peening, ensure that the rivets do not protrude beyond the flange knurling.

Inspection

3. The repair must be to the satisfaction of the supervising inspector A.I.D., C.I.O./N.A.I. or C.I.O./A.I.S.

Identification

4. After satisfactory completion of the repair, use $\frac{1}{8}$ in. metal stamps to mark "RP.187" below the assembly issue number on the wheel. After marking the wheel, paint the indentations with selenious acid solution.

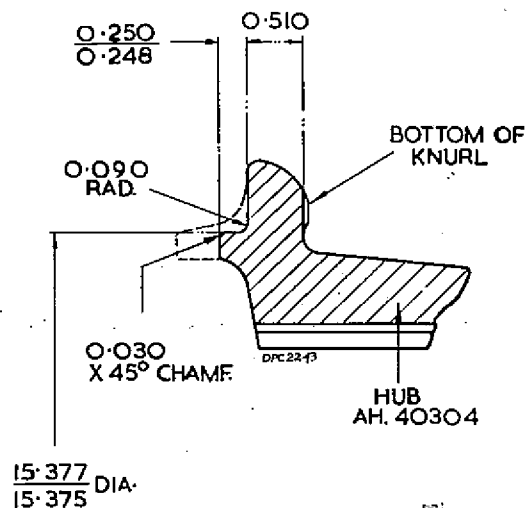

(ALL DIMENSIONS ARE IN INCHES)
RP187/1

Fig. 1. Machining dimensions of the flange

(A.L.65, Feb. 58)

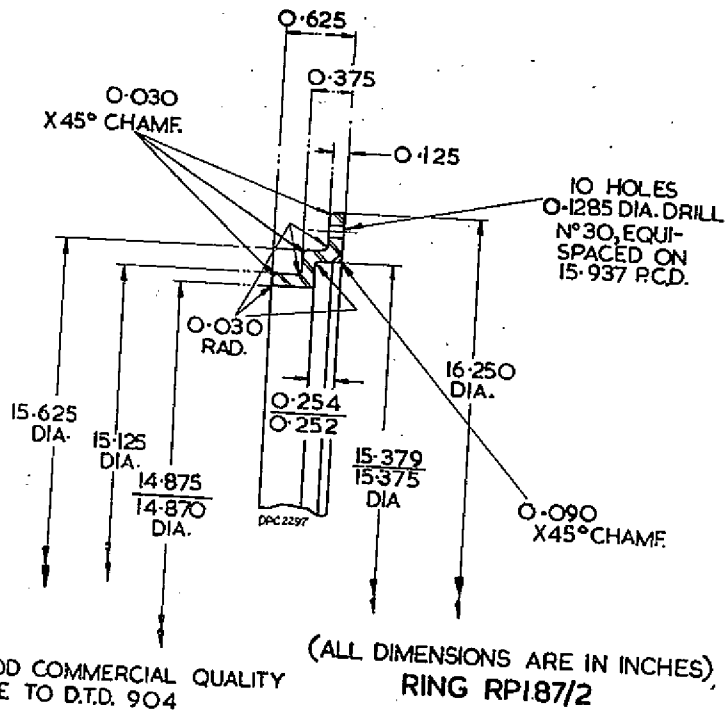

Fig. 2. Dimensions of ring

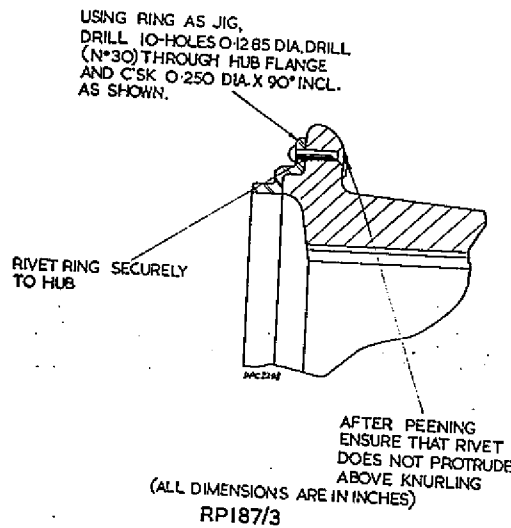

Fig. 3. Assembling of ring to wheel flange

RESTRICTED

Introduc

1. Th
remov
shrou
the s
drive

Methr

2.

(2)

(3)

(4)

RP.188

REMOVING CORROSION FROM DRIVE BLOCK RECESSES

Introduction

1. This scheme deals with a method of removing the corrosion from the drive block recesses in the wheel hub by detaching the shrouds, machining the hub, and re-fitting the shrouds to which have been spotwelded drive block supporting strips.

Method of repair

2. (1) Dismantle and degrease the wheel.
- (2) Remove the paint as detailed in Vol. 1, Book 1, Sect. 1, Chap. 1.
- (3) Drill out the rivets securing the shrouds to the wall of the brake housing and remove the drive blocks.
- (4) Using a locating base in conjunction with the wheel hub, set up the wheel in a slotting machine and form 10 slots 2.187/2.184 in. wide in the rim to the 13.593 in. dimension with 0.030 in. radii in the corners as shown in RP.188/1 (fig. 1). Check the measurements obtained using a slip gauge and pin gauges.
- (5) Remove the swarf, and protect the newly-machined surfaces with selenious acid solution made from 2 oz. selenious acid crystals dissolved in one pint of water.

WARNING

Selenious acid crystals or solution must not be allowed to come into contact with the skin.

- (6) Using a spotwelding fixture, lightly spotweld two strips, Part No. RP.188/2 (fig. 2) to each shroud, Part No. AHM.

2812 as detailed in RP.188/3 (fig. 3). Check the 0.505/0.500 in. measurements using slip gauge Part No. AO.34303.

- (7) Coat the drive block abutment faces in the hub with pigmented varnish jointing compound (Stores Ref. 33C/1264).
- (8) With the pegs, Part No. AHO.27647, remount the drive blocks on each shroud.
- (9) Using support, Part No. A.M.19412, rivet the shrouds to the hub as shown in RP.188/4 (fig. 4). Check for security.

Inspection

3. The repair must be to the satisfaction of the supervising inspector A.I.D., C.I.O./N.A.I. or C.I.O./A.I.S.

Painting

4. Repaint the hub as described in Vol. 1, Book 1, Sect. 1, Chap. 1.

Identification

5. After satisfactory completion of the repair, "RP.188" is to be stamped immediately below the Assembly Issue Number on the face of the wheel with $\frac{1}{8}$ in. metal stamps. After marking the wheel, paint the indentations with selenious acid solution.

New parts

6. The following new parts are required to carry out this repair:—

Part No.	Description	No. off per wheel
RP.188/2	Strip	20
AS.457/508	Rivet	10
AS.457/513	Rivet	10

LES
IA. DRILL
QUI-
ON
CD.

S)

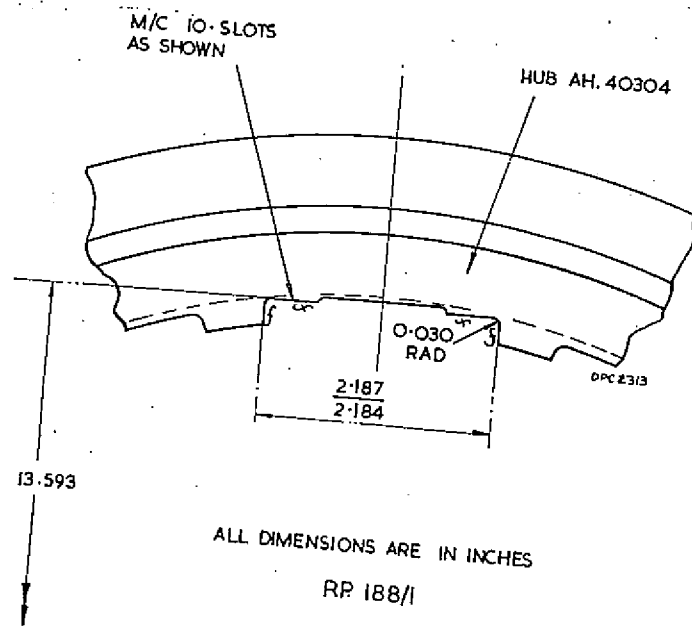
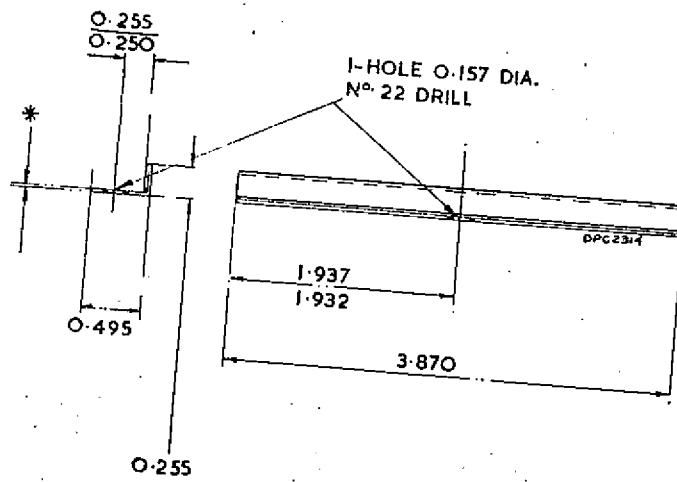

Fig. 1. Machining dimensions for hub



ALL DIMENSIONS ARE IN INCHES

MATERIAL: * 28 SWG. (0.015)
STAINLESS STEEL 18/8 WELD DECAY
FREE- ANNEALED CONDITION

STRIP RP 188/2

Fig. 2. Dimensions of supporting strip

RESTRICTED

P 464
8. 62

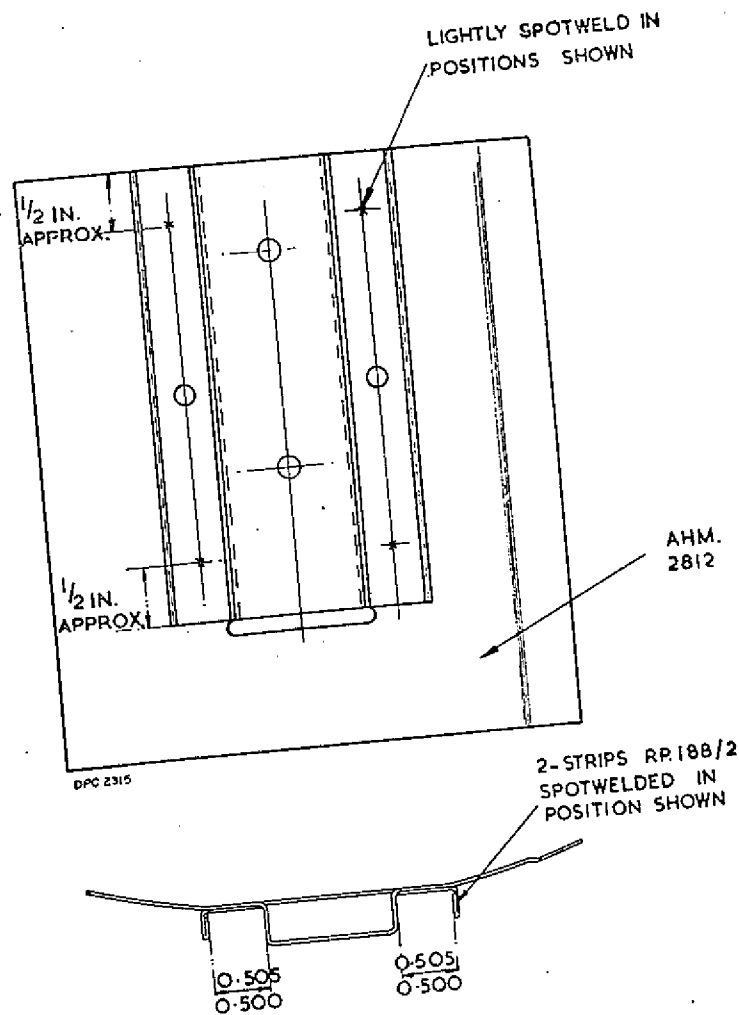

ALL DIMENSIONS ARE IN INCHES
RP. 188/3

Fig. 3. Dimensions of assembled shroud and strip

(A.L.64, Feb. 58)

~~RESTRICTED~~

F.S./2

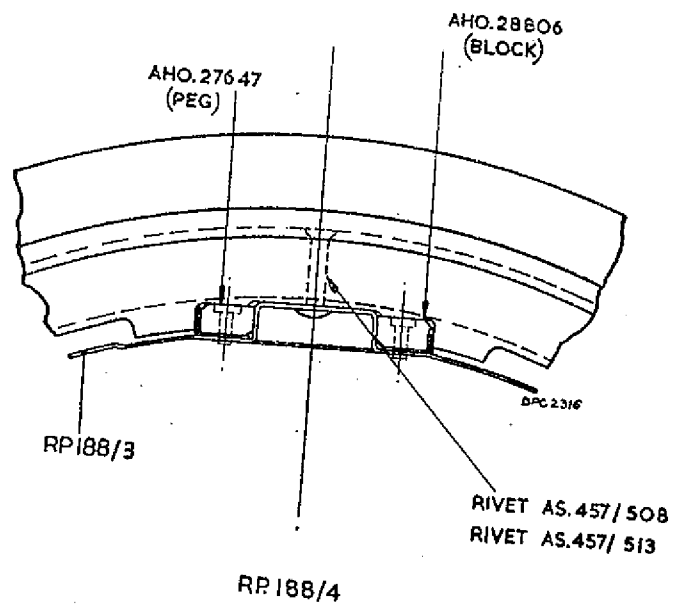

Fig. 4. Details of repaired hub

In
1.
re
b
b
n
M
2

RP 195

RE-FITTING OF LOOSE DRIVE BLOCKS TO WHEELS

464
7. 62**Introduction**

1. This repair scheme may be used for the repair of any main wheels in which the drive block screw(s) locked by peening have become loose. Individual loose drive blocks may be re-locked.

Method of repair

2. (1) Remove the drive block screws by using (if necessary) the ratchet and special screwdriver bit (Table 1). The bit of the screwdriver is held in position in the slot of the screw by a jack, locally made from a hexagon bolt cut to a suitable length, and a nut. The bolt is tightened sufficiently to enable the screwdriver bit to be held firmly in position. A sharp turn of the screwdriver will shear any peening that may remain. Retain the drive block screws if they are not damaged.
- (2) Machine a locking screw slot in each drive block screw. This slot must be cut through the full thickness of the screw head, the bottom of the slot must be in line with the outside diameter of the thread, and the slot must be of 0.067 in. width. The location of the slot in the screwhead varies as follows:—
- (a) For a $\frac{1}{8}$ in. B.S.W. drive block screw, the slot can be in any position around the head.
- (b) For a $\frac{5}{16}$ in. B.S.W. or $\frac{3}{8}$ in. B.S.W. drive block screw, the slot must be in alignment with the screwdriver slot.
- (3) With the drive block screws, secure the drive blocks to the tenons using the special screwdriver bit and holder. With the locking screw slot in the screw head used as a template, drill with a No. 51 (0.067 in.) drill the holes for the small screws to lock the drive block screws.

- (4) For wheels with $\frac{5}{16}$ in. B.S.W. or $\frac{3}{8}$ in. B.S.W. drive block screws, drive in the locking screws until they are flush with the bottom of the screwdriver slot; but for wheels with $\frac{1}{8}$ in. B.S.W. drive block screws, drive in the locking screws until they are flush with the surface of the screw head.

Identification

3. After satisfactory completion of the repair, "RP 195" is to be stamped immediately below the Assembly Issue No. of the wheel with $\frac{1}{8}$ in. metal stamps. Paint the indentations with selenious acid solution made up of 2 oz. selenious acid crystals dissolved in one pint of water.

New parts

4. The undermentioned new parts are needed to carry out this repair:—

Ref. No.	Description	No. off
No. 0 × $\frac{1}{4}$ in. long	Screw, Parker Kalon (headless type U)	As required

Inspection

5. The repair must be to the satisfaction of the supervising inspector A.I.D., C.I.O./N.A.I. or C.I.O./A.I.S.

TABLE 1
Special tools

Part No.	Description
MSD 206	Screwdriver bit ($\frac{3}{8}$ in. drive)
RPS 206	Ratchet handle ($\frac{3}{8}$ in. drive)
AO.49801	Holder for screwdriver bit
—	Jack (made up locally from a hexagon bolt cut to a suitable length, and a nut)

(A.L.67, Mar. 58)

F.S./1

B (AL67)

RESTRICTED

RP 204

REPAIR TO WORN SHROUD AND SHROUD PLATE RIVET HOLES

Introduction

1. Elongated or worn holes which are used to rivet the shroud and shroud plate to the wheel hub may be enlarged and fitted with oversize rivets.

2. Each hole may be repaired individually and it is not necessary to repair holes which are unworn.

3. The scheme deals with various stages of reclaim for each wheel and the particular stage of repair is dependent upon the worn diameter of hole(s).

4. Rivet holes for wheels AH.50207 and AH.50701 adjacent to the fixed flange and the end of the valve slot can only be reclaimed twice according to the details laid down for first and second stage reclaim.

5. The rivets used in repair are made from other rivets as enumerated in the end column of the Table. Exceptions are the 2nd and 4th stage of reclaim for wheel AH.51154. Other exceptions may follow if any new wheels are added to the scheme.

Method of repair

6. (1) Dismantle and degrease the wheel.
- (2) Drill out the faulty rivet(s) and remove the shrouds.
- (3) Determine the stage of repair and open out the rivet holes in the hub to the

limits given in columns A and B and the shroud holes to the limits given in column C. The shroud plate must be enlarged to the limits given in columns M and N.

- (4) Details of the rivet sizes for any particular stage of reclaim are given in columns D, E, F, G and H for one type of rivet and in columns J, K and L for another.
- (5) Clean the repaired surfaces of the wheel and apply selenious acid solution made from 2 oz. selenious acid crystals dissolved in one pint of water.
- (6) Secure the shrouds and shroud plates to the hub with the repair rivets. File the ends of the rivet at the outside periphery of the wheel to blend with the wheel contour. Treat the repaired surface with selenious acid solution.

Inspection

7. This repair scheme must be to the satisfaction of the supervising inspector A.I.D., C.I.O./N.A.I., or C.I.O./A.I.S.

Identification

8. After satisfactory completion of the repair stamp RP 204 on the flange at the outer surface of the wheel adjacent to the rivet holes which have been repaired. Use $\frac{1}{8}$ in. letters and paint the indentations with selenious acid solution.

TABLE 1
Details of rivet holes and rivets
 1. The code letters at the head of the columns refer to the corresponding letters shown in the illustration.

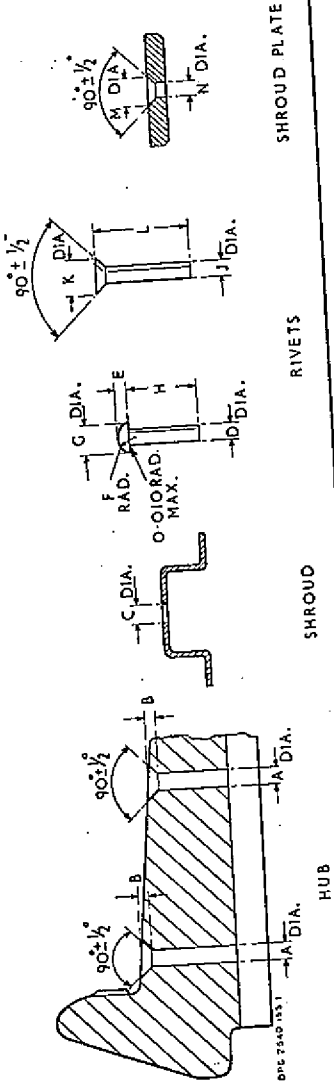

Wheel Part No.	Re-claim No.	Dimensions of rivet holes (Shroud)								Dimensions of rivets								Repair rivets
		A	B	C	D	E	F	G	H	F	G	H	H					
AH.50207*	1	0-145	0-065	0-180	0-142	0-085	0-155	0-275	0-755	0-942	Make rivets AS.457/512 from AS.457/515							
		0-140	0-055	0-170	0-136	0-075	0-145	0-265	0-745	0-932	Make rivets AS.457/512 from AS.457/515							
	2	0-161	0-065	0-196	0-158	0-085	0-155	0-275	0-755	0-942	Make rivets AS.457/612 from AS.457/615							
		0-156	0-055	0-186	0-152	0-075	0-145	0-265	0-745	0-932	Make rivets AS.457/612 from AS.457/615							
AH.50701*	3	0-175	0-065	0-210	0-172	0-085	0-185	0-335	0-755	0-942	Make rivets AS.457/608 from AS.457/613							
		0-170	0-055	0-200	0-166	0-075	0-175	0-325	0-745	0-932	Make rivets AS.457/608 from AS.457/613							
	4	0-192	0-065	0-228	0-189	0-085	0-185	0-335	0-755	0-942	Make rivets AS.457/708 from AS.457/713							
		0-187	0-055	0-218	0-183	0-075	0-175	0-325	0-745	0-932	Make rivets AS.457/708 from AS.457/713							
AH.9982	1	0-175	0-065	0-210	0-172	0-095	0-185	0-335	0-505	0-817	Make rivets AS.457/608 from AS.457/613							
		0-170	0-055	0-200	0-166	0-085	0-175	0-325	0-495	0-807	Make rivets AS.457/608 from AS.457/613							
	2	0-192	0-065	0-228	0-189	0-095	0-185	0-335	0-505	0-817	Make rivets AS.457/708 from AS.457/713							
		0-187	0-055	0-218	0-183	0-085	0-175	0-325	0-495	0-807	Make rivets AS.457/708 from AS.457/713							
	3	0-207	0-065	0-242	0-204	0-095	0-215	0-385	0-505	0-817	Make rivets AS.457/708 from AS.457/713							
		0-202	0-055	0-232	0-198	0-085	0-205	0-375	0-495	0-807	Make rivets AS.457/708 from AS.457/713							
	4	0-223	0-065	0-260	0-220	0-095	0-215	0-385	0-505	0-817	Make rivets AS.457/708 from AS.457/713							
		0-218	0-055	0-250	0-214	0-085	0-205	0-375	0-495	0-807	Make rivets AS.457/708 from AS.457/713							

*Rivet holes adjacent to fixed flange end of valve slot can only be reclaimed twice.

(A.L.70, July 58)

RESTRICTED

TABLE 2
Details of rivet holes and rivets

1. The code letters at the head of the columns refer to the corresponding letters shown in the illustration

Wheel Part No.	Re-claim No.	Dimensions of rivet holes (Hub)				Dimensions of rivets				Rivet hole in Shroud Plate		Repair rivets
		A	B	C	(Shroud)	J	K	L	M	N		
AH.51154	1	0.175 0.170	0.065 0.055	0.210 0.200	0.172 0.166	0.333 0.323	0.692 0.682	1.005 0.995	0.333 0.323	0.179 0.176	Make rivets AS.462/611 from AS.462/616	
	2	0.192 0.187	0.065 0.055	0.228 0.218	0.189 0.183	0.333 0.323	0.692 0.682	1.005 0.995	0.333 0.323	0.179 0.176	Use rivets AS.462/611 and AS.462/616	
	3	0.207 0.202	0.065 0.055	0.242 0.232	0.204 0.198	0.388 0.378	0.692 0.682	1.005 0.995	0.388 0.378	0.211 0.208	Make rivets AS.462/711 from AS.462/716	
	4	0.223 0.218	0.065 0.055	0.260 0.250	0.220 0.214	0.388 0.378	0.692 0.682	1.005 0.995	0.399 0.378	0.227 0.224	Use rivets AS.462/711 and AS.462/716	

TABLE 3
Special Tools

The following is a list of special tools needed to carry out this repair scheme on individual wheels:—

Wheel Part No.	Tool Part No.	Description
AH.50207	AO.52938	Riveting support
AH.50701	AO.52938	Riveting support
AH.9982	AM.19412	Riveting support
AH.51154	A.9982	Riveting support

RESTRICTED.

Intr
1. hut
rin
ov
RI

M
2. C
C

RP 209 RECLAIMING LOCK RING GROOVE ON WHEEL Part No. AHO.5048

P 464
g. 62

Introduction

1. Due to wear the lock ring groove in the hub may be oversize. To repair this the lock ring groove and the loose flange are machined oversize and a new lock ring Part No. RP.209/3 is fitted.

Method of repair

2. (1) Dismantle and degrease the wheel.
- (2) Remove the paint as described in Vol. 1, Sect. 1, Chap. 1.
- (3) Mount the wheel hub in a lathe with the radiused locking groove outwards. It must then be set up so that the hub runs true in both the vertical and horizontal planes; to check for truth apply a dial test indicator to the hub; the maximum permitted D.T.I. variation is 0.002 in.

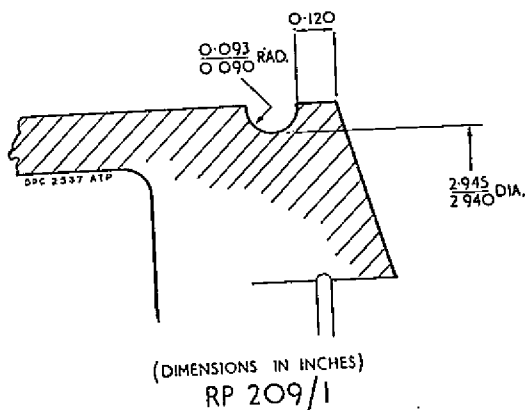

Fig. 1. Lock ring groove

- (4) Machine the lock ring groove to the dimensions given in RP.209/1 (fig. 1).
- (5) Remove the wheel hub from the lathe and set up and machine the loose flange to the dimensions given in RP.209/2 (fig. 2).
- (6) Treat locally the machined faces of both the wheel hub and the loose flange with

- (a) Selenious acid solution (made from 2 oz. selenious acid crystals dissolved in one pint of water) if the wheel is made from elektron.
- or
- (b) If the wheel is made from aluminium alloy no local treatment is applied but the wheel must be painted as soon as possible (refer to para. 4.)

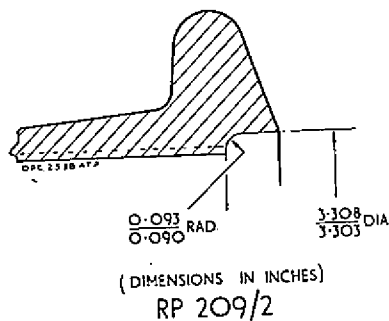

Fig. 2. Loose flange dimensions

Note . . .

The material from which the hub is made may be identified by the stroke number which follows the serial number of the wheel. Thus:—

- /1 indicates elektron
- /2 indicates aluminium alloy

Inspection

3. The repair must be to the satisfaction of the supervising inspector A.I.D., C.I.O./N.A.I. or C.I.O./A.I.S.

Identification

4. After satisfactory completion of the repair use $\frac{1}{8}$ in. metal stamps to mark "RP.209" below the assembly issue number on the wheel. After marking the wheel, paint the indentations with selenious acid solution on elektron hubs and flanges only.

(A.L.70, July 58)

RESTRICTED

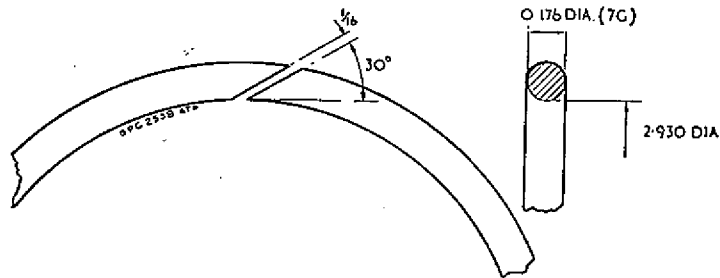

MAT⁴ STAINLESS SPRING STEEL
SPEC. D.T.D. 239

(DIMENSIONS IN INCHES)
RP 209/3

Fig. 3. Lock ring

Painting

5. Repaint the hub as described in Vol. 1, Sect. 1, Chap. 1.

New part

6. The undermentioned new part is required to embody this repair:—

Part No.	Description	No. off
RP.209/3	Lock ring	1

RESTRICTED

F.S./1

Int
1.
be
lo
ar
be
N

2
1
:

RP 345

REPAIR OF BEARING HOUSINGS

WHEEL AH.50787

P 464
Aug. 62

Introduction

1. To repair bearing housings which have become so enlarged that the bearings are loose in the housings. When this condition arises the wheel is machined and a steel bearing housing is fitted.

Note . . .

Bearing creep in a housing is permissible provided that the bearing is not loose in the housing.

2. This repair scheme can be used in lieu of RP.60 or as a secondary repair should the shimmed bearing fail.

New parts

3. The following new parts are required to carry out this repair:—

Part No.	Description	No. off
AHM. 5540	Bearing housing	1
AHO. 35699	Bolt	10
AHO. 35700	Washer	10
AHO. 25832	Nut	10
AHO. 35705	Circlip	1
AHO. 35706	Excluder	1

Requirements

4. Araldite D and Hardener 951 (D.T.D. 900/4365). Selenious acid solution: make from 2 oz. selenious acid crystals dissolved in one pint of water.

Method of repair

5. (1) Dismantle and degrease the wheel.
- (2) Remove the paint as detailed in Vol. 1, Sect. 1, Chap. 1.
- (3) Mount the wheel hub in a lathe so that the chuck jaws locate on the loose flange side of the wheel. Set up the hub so that it runs true in both the vertical

and horizontal planes. To check for truth apply a dial test indicator to the bearing housing. The maximum D.T.I. variation permitted is 0.002 in.

(4) Machine the opposite side of the hub to the dimensions given in fig. 1.

(5) Clean the machined surfaces and coat them with selenious acid solution.

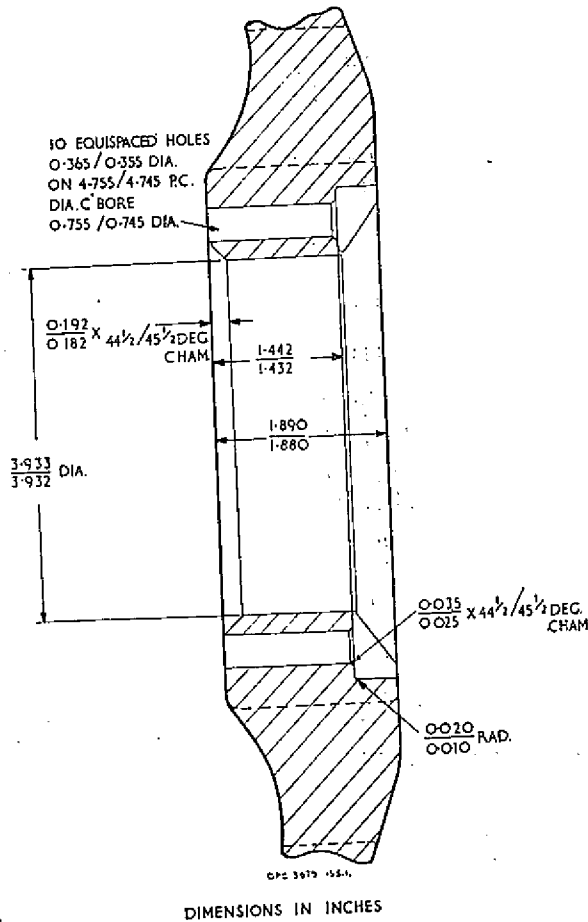

Fig. 1. Dimensions for machining hub RP 345

RESTRICTED

by
i.)
d
h
f

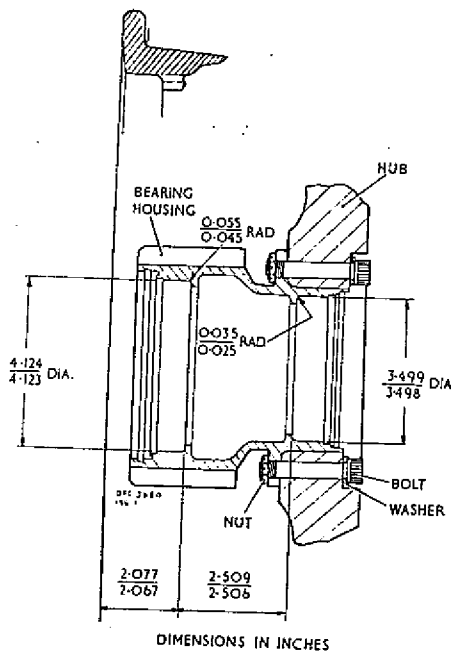

Fig. 2. Machining bearing housing bore
RP 345

- (6) Machine 10 holes (equispaced between the lightening holes) to the dimensions given and at the location shown in fig. 1.
- (7) Protect the bare metal with selenious acid solution. If facilities are available the wheel must be black chromated (D.T.D. 911).
- (8) Heat the hub to a temperature of 150 deg. C by placing it in a muffle furnace. Coat the hub bore and the mating surfaces of the steel housing with the Araldite D and Hardener 951.
- (9) Line up the 0.360 in. dia. holes and press in the bearing housing. There must be no gap between the flange of the housing and the butment face of the hub; check this with a 0.0015 in. thick feeler gauge.
- (10) When the hub is cool ream the 0.360 in. dia. holes to 0.375/0.376 in. dia. Protect the bare metal with selenious acid solution.
- (11) Fit the bolts and washers to the bearing housing, grease the bolts, then tighten the nuts to a torque loading of

20 lb. ft. Lock the nuts by peening the metal of the bolts into the slots.

(12) Set up the wheel in a lathe as in operation (3) and machine the bearing housing bore to the dimensions given in fig. 2.

(13) Grease the machined faces of the bearing housing.

(14) Assemble the bearing housing components as shown in fig. 3. Use the old parts for assembling, but a new excluder and circlip is necessary at the loose flange side of the bearing housing.

Inspection

6. The repair must be to the satisfaction of the supervising inspector A.I.D., C.I.O./N.A.I. or C.I.O./A.I.S.

Identification

7. After satisfactory completion of the repair use $\frac{1}{8}$ in. metal stamps to impress "RP.345" adjacent to the wheel assembly number. Protect the indentations with selenious acid solution.

Painting

8. Repaint the hub as described in Vol. 1, Sect. 1, Chap. 1.

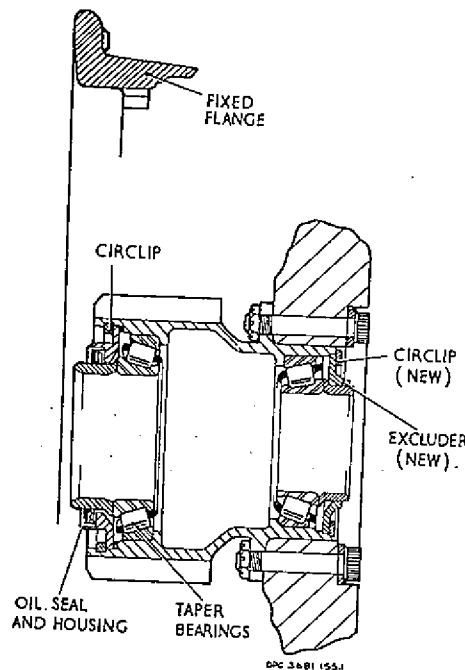

Fig. 3. Bearing housing components RP 345

RESTRICTED

RP 418

REMOVAL OF CORROSION FROM AROUND THE VALVE HOLE OF WHEEL

PART NO. AH.50207, AH.50701

Scheme

1. To remove corrosion from around the valve hole and from the area covered by the metal washer in the tube base support.

Method of repair

2. (1) Dismantle the wheel in accordance with Vol. 1, Book 1, Sect. 1, Chap. 1.
- (2) Vapour blast to remove the corrosion (refer to Vol. 1, Book 1, Sect. 1, Chap. 1).
- (3) Measure the depth of pitting in the affected area and if at any point this is in excess of 0.1 in. the wheel cannot be reclaimed. If, however, the depth of pitting is within the limit, proceed as follows.
- (4) Remove the shroud rivet if corrosion is present around the rivet spread.
- (5) Re-countersink the rivet hole with a 90 deg. inclusive angle cutter to provide a setting for spreading the shroud rivet.
- (6) If necessary, shorten the new rivet as required, then rivet it in position.
- (7) Treat the bare metal with selenious acid solution.

- (8) Restore the profile of the wheel by filling the required area with Araldite 121N.

Identification

3. With $\frac{1}{8}$ in. metal stamps, imprint RP. 418 adjacent to the assembly issue number of the wheel. Treat the bare metal with selenious acid solution.

Painting

4. Repaint the wheel in accordance with Vol. 1, Book 1, Sect. 1, Chap. 1.

Inspection

5. The repair must be to the satisfaction of the supervising inspector A.I.D., C.I.O./N.A.I. or C.I.O./A.I.S.

New parts

6. The undermentioned new part is required to carry out this repair.

Part No.	Description	No. off
AS.457/412	Shroud rivet	1 (if required)

Requirements

7. Selenious acid solution:—Make from 2 oz. selenious acid crystals dissolved in one pint of water.
Araldite 121N.

by
1.)
id
sh
of

f
/

RESTRICTED

RP.423

WHEEL PART NO. AH.50439 AND AH.51337

P 464
48.62

INTRODUCTION

1. This repair scheme is to repair main wheels in which the drive block screw(s) and insert(s) have become loose, damaging the tapped threads.

Note...

Where only the wire insert is damaged but not its threaded hole, the wire insert may be renewed as detailed in Sect.1, Chap.1, App.4 of this volume.

2. The inner drive block hole(s) of main wheel AH.51337 are not at present repaired at user units in accordance with this scheme.

by
)
d
h
f

METHOD OF REPAIR

3. To repair the damaged or stripped thread of a tapped hole fitted with a wire thread insert proceed as follows:-

- (1) Remove the adjacent drive block from the same tenon recess.
- (2) Select the appropriate drilling/tapping jig set (Table 1, Items 1 to 3) for the relevant wheel and drive block position.
- (3) Clean off the old jointing compound and the paint from within the tenon recess to allow the fit of the drilling jig.
- (4) Fit the reduced length end cutter (Table 1, Item 4) into the drilling machine (Table 1, Item 6) and ensure that the length of the end cutter protruding from the chuck jaws is 1.060 in.

Note...

The drill chuck jaws face, contacting the drilling jig face is the correct depth stop. (Hole depth 0.435 in.).

- (5) (a) Wheel AH.50439, insert the end cutter into the working hole in the drilling jig, slide the drill and the jig together into the wheel tenon recess. Position two 1/4 in. B.S.W. bolts 1 in. long through the drilling to engage the threads of the drive block securing holes in the hub adjacent to the drive block securing holes which are being repaired. Tighten the jig into position.

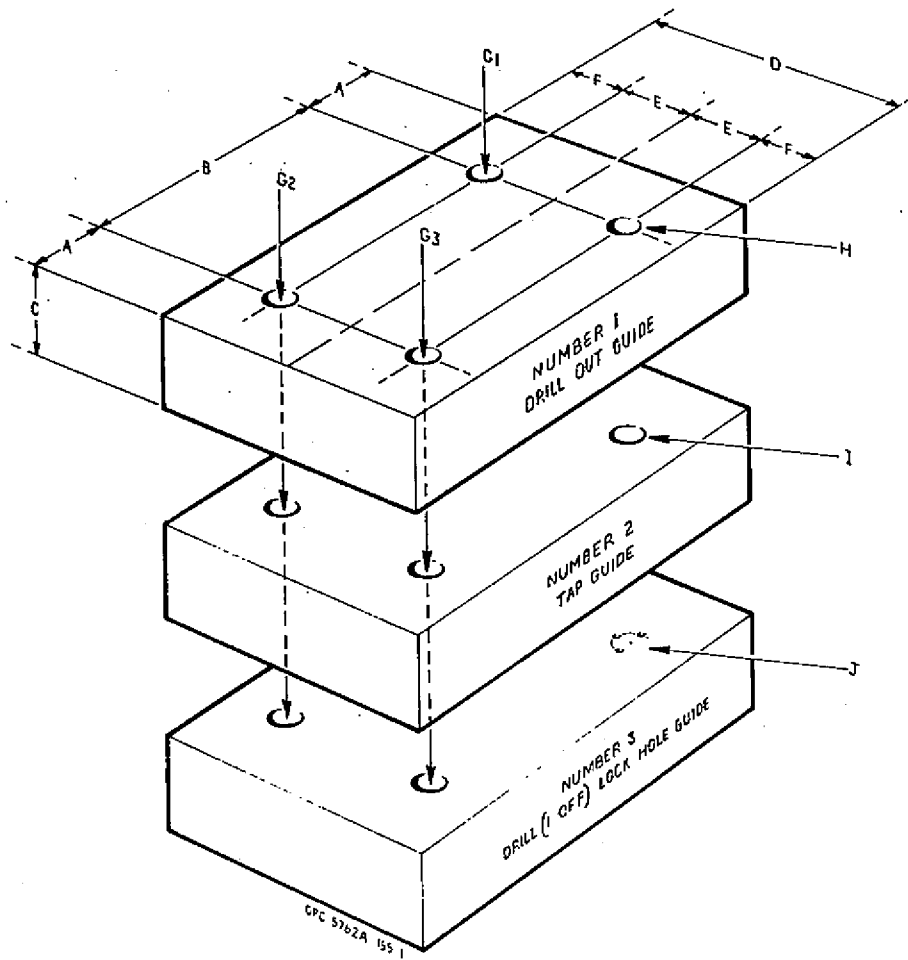

Fig. 1 Locally made drilling/tapping jigs

(b) Wheel AH.51337, fit the drilling jig into the tenon recess. Position two $\frac{1}{4}$ in. B.S.W. bolts 1 in. long through the drilling jig to engage the threads of the drive block securing holes in the hub adjacent to the drive block securing holes which are being repaired. Tighten the jig into position.

(6) Drill the damaged hole to $\frac{3}{8}$ in. dia. and remove the swarf by applying a low pressure compressed air blast. Ensure the hole is thoroughly dry.

(7) Remove the drilling jig and fit the tapping jig. Secure it with the bolts.

(8) Using items 7 and 8 (Table 1) in conjunction with a crescent spanner, carefully cut the $\frac{7}{16}$ in. B.S.F. thread. Remove the swarf as detailed in sub-para.(6). Check the final depth of the tapped thread by trial and error with a steel plug.

(9) issu
 (10) incl
 AP 3
 blas
 (11) var
 its
 doe
 (12) req
 (13) (T
 fro
 No
 (14) 1/
 (15) 33
 Se
 (16) t
 (17) d
 t
 (18) c
 (19) 1
 AL 10

(9) With 1/8 in. metal stamps impress RP.423 adjacent to the assembly issue number of the wheel.

2464
7.62

(10) Apply selenious acid solution to all exposed metal surfaces including threads and the stamped impression in accordance with ◀ AP 119A-0601-1C, Chap.5. ▶ Dry with a low pressure compressed air blast.

(11) Lightly coat the threads of the steel plug with pigmented oil varnish jointing compound (Ref.33H/2202110) and screw the plug into its housing in the wheel until it bottoms. Ensure that the plug does not protrude above the surface.

(12) Fit the lock hole drilling jig (Table 1, Item 1, 2 or 3) as required into the tenon recess and secure it with the two bolts.

(13) Fit the drill (Table 1, Item 5) into the drilling machine (Table 1, Item 6) and ensure that the length of drill protruding from the chuck jaws is 0.937 in. Drill a hole No.51 0.067 in. dia.

Note...

The drill chuck jaws face, contacting the drilling jig face, is the correct depth stop. (Hole depth 0.312 in.).

(14) Lock the plug by driving the P.K. locking screw 0 dia. x 1/4 in. long.

(15) Refit the old drive blocks using pigmented oil varnish (Ref. 33H/2202110) applied to the mating surfaces of the drive block. Secure the drive blocks using the new screws.

(16) Check that a 0.0015 in. feeler gauge cannot be inserted between the wheel and the underside of the drive block.

(17) Drill with a No.51 (0.067 in.) drill new locking holes 0.312 in. deep at different locations from the originals, through the slots in the screw heads and into the drive blocks.

(18) Drive in the locking screws until they are flush with the surface of the drive block.

Note...

There are three drive block dowel screws used also with the normal drive block screws for retaining the inner drive blocks of wheel AH.50439. Care must be taken to ensure that if one of these is removed in the repair, it is replaced by a similar dowel screw.

4. The repair must be to the satisfaction of the Supervisory Inspecting Authority.

5. ◀ Re-assemble wheel Part No. AH.51337 in accordance with Vol.1, Book 1, Sect.1, Chap.1, App.107 of this Air Publication and wheel Part No. AH.50439 in accordance with AP.104F-1016-1. ▶

ASSEMBLY COMPOUNDS

6. Selenious acid solution. Make from 2 oz. selenious acid crystals (Ref.33C/2200748) dissolved in one pint of water. Pigmented oil varnish jointing compound (Ref.33H/2202110).

NEW PARTS

7. The following new parts are required to carry out this repair:-

Ref. No.	Part No.	Description	Quantity
27A/4071	AHO.38001	Drive block screw ◀ 1/4 in. B.S.W. ▶	As required
27A/4072	AHO.38156	Dowel screw	As required
	0 dia. x 1/4 in.	Screw, Parker Kalon headless type U	As required
	AHO.81350	Plug, tapped ◀ 1/4 in. B.S.W. ▶ external thread 7/16 in. B.S.F. x 0.435 in. long	As required

SPECIAL TOOLS

8. The special tools listed in Table 1 are required to carry out this repair:-

Ref. No.	Part No.	Description	Quantity	Item No.
		Drilling/tapping jigs consisting of 3 blocks (Wheel AH.50439 repair to inner drive block holes)	1 set	1
		Drilling/tapping jigs consisting of 3 blocks (Wheel AH.50439 repair to outer drive block holes)	1 set	2
		Drilling/tapping jigs consisting of 3 blocks (Wheel AH.51337 repair to outer drive block holes)	1 set	3

Note...

The drilling/tapping jigs are designed by

Ref.

3E

Ref. No.	Part No.	Description	Quantity	Item No.
		C.S.D.E. and are made locally. Where facilities are insufficient to permit local manufacture jigs may be obtained by application to Maintenance Command		
3B/474		3/8 in. end cutter 2 5/8 in. total length, 7/8 in. cutting length (Reduce shank length to give overall length 1.980 in.)	1	4
1G/9108554		No.51 or 1.7 mm. drill (P.K. locking screw holes in threaded plug and drive blocks)	1	5
3A/		Right-angled pneumatic drilling machine fitted with 3/8 in. chuck	1	6
1C/3360		Taps taper 2nd 7/16 in. B.S.F. (use with crescent spanner)	1	7
1C/3359		Taps, bottoming, 7/16 in. B.S.F. (Grind off lead on plug tap to permit full depth of cut in hole. Use with crescent spanner)	1	8

DETAILS OF DRILL/TAP JIGS
(Refer to fig.1)

Fig.1 ref.	Wheel AH.51337 Outer drive blocks (in.)	Wheel AH.50439 Outer drive blocks (in.)	Wheel AH.50439 Inner drive blocks (in.)	Remarks
A	1.000	0.500	0.750	1. Manufacture from 30A/2966 mild steel bar 3 in. x 1 in. Quantity as required.
B	1.750	1.812	1.250	2. 29A/1204143. Bolts precision 1/4 in. B.S.W. x 1 in.
D	2.446/2.444	2.500/2.498	2.248/2.246	3. File 0.030 in. radius on each long side edge of each block.
E	-	◀ 0.938/0.937	0.812/0.811 ▶	4. Case harden finished blocks
F	0.312	-	-	Holes to be within 0.002 in. of nominal position
G	Initially pilot drill hole, open up to 0.242 in. with a letter C drill, ream to 1/4 in. (3 off holes in each guide block)			Bolt holes
H	Initially pilot drill hole, open up to 3/8 in. to accommodate 3/8 in. end cutter (1 off hole in guide block number 1)			
I	Initially pilot drill hole, open to 29/64 in. to accommodate 7/16 in. B.S.F. tap (1 off hole in guide block number 2)			
J	Scribe an arc 0.200 in. effective radius, from a centre projected through holes H and I. Drill 3 holes with a No.51 drill around 180 deg. of the scribed arc in the direction of hole G1)			Position of holes around the scribed arc is not critical

RP 464

REPAIR TO DRIVE BLOCK TENONS
WHEEL PART NO. AH.9729

Scheme

1. To repair worn inner drive block tenons by machining the tenon abutment faces and fitting non-standard drive blocks. Original drive block tenon wear is permissible down to a width of 0.488 in. When the drive block tenon width has worn to 0.488 in. the tenon may be repaired according to the 1st stage repair, and wear after this repair is permissible down to a width of 0.454 in. At this limit the drive block tenon must be machined according to the 2nd stage repair. Wear after this repair is permissible down to 0.425 in. at which limit the wheel is scrap.

2. Repair only those drive block tenons which are sufficiently worn as laid down in paragraph 1.

Method of repair

3. (1) Dismantle and degrease the wheel (refer to Vol. 1, Book 1, Sect. 1, Chap. 1).
(2) Shear the small Parker Kalon pegs as follows:—
(a) Hold the bit of the screwdriver in position in the slot of the screw by the locally-made jack. Tighten the jack sufficiently to enable the screwdriver bit to be held firmly.
(b) Turn the screwdriver sharply to shear each Parker Kalon locking peg.
(3) Remove the drive block screws and the drive blocks from the worn tenons.
(4) Machine the side faces of the tenons to the required dimension (fig. 1).
(5) Treat the bare metal with selenious acid solution.
(6) Coat the mating surfaces of the drive blocks liberally with pigmented oil varnish jointing compound D.T.D.369. With the screws tightly secure the new drive blocks to the tenons.

(7) Lock the drive block screws by drilling $\frac{1}{8}$ in. deep with a No. 51 (0.067 in.) drill through the slot in the screwhead and into the drive block. Drive in each pin so that it is flush with the surface of the drive block.

4. The repair must be to the satisfaction of the supervising inspector A.I.D., C.I.O./N.A.I. or C.I.O./A.I.S.

Special tools

5. The following special tools are required to embody this repair:—

Part No.	Description
MSD. 206	Screwdriver bit ($\frac{3}{8}$ in. drive)
RPS. 206	Ratchet handle ($\frac{3}{8}$ drive)
—	Jack (made up locally from a hexagon bolt cut to a suitable length, and a nut)
AO. 49801	Holder for screwdriver bit

Identification

6. After satisfactory completion of the repair use $\frac{1}{8}$ in. metal stamps to impress RP. 464 below the assembly issue number of the wheel. Treat the indentations with selenious acid solution.

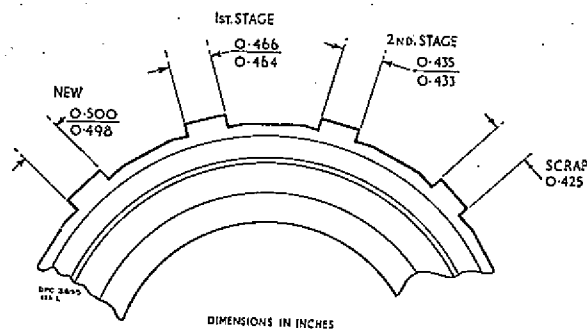

Fig. 1. Machining side faces of tenons RP 464

RESTRICTED

ARC IS NOT CRITICAL

SECTION 2

1
e

New parts

7. The following new parts are required to carry out this repair scheme:—

Part No.	Description	No. off per unit
AHO. 81685	Inner drive block (<i>1st stage</i>)	As required
AHO. 81686	Inner drive block (<i>2nd stage</i>)	As required
AHO. 38214	Inner drive block screw	As required
Type U	Peg (<i>Parker Kalon</i>) "O" dia. $\times \frac{1}{4}$ in. long (<i>headless</i>)	As required

Requirement

8. Selenious acid solution: make from 2 oz. selenious acid crystals dissolved in one pint of water.
Pigmented oil varnish jointing compound D.T.D. 369.

RESTRICTED

RP.480

REPAIR OF WORN MAXARET TRACKS

1. The wheels affected by this repair scheme are given in Tables 1, 2 and 3.

2. The following items are required:—

(1) Selenious acid solution. Make from 2 oz. selenious acid crystals dissolved in one pint of water.

(2) Alocrom 1200.

3. Dismantle the wheel in accordance with Vol. 1, Book 1, Sect. 1, Chap. 1. Examine the hub and if it does not conform to the following limits it cannot be repaired by this scheme.

(1) Refer to Table 1, 2 or 3 and check that diameter A of the appropriate hub does not exceed the maximum.

(2) Check that dimension D is not less than the figure quoted, this is particularly important if RP.453 has already been incorporated in the wheel.

(3) Wheel AH.51631 only. Examine the wheel for distortion, check the diameter at point X and ensure that it does not exceed the figure given in Table 1.

(4) Check the hub for local distortion by mounting the hub on its bearings and applying a dial test indicator to the Maxaret track. Local distortion must not exceed 0.030 in.

Method of repair

4. Machine the Maxaret track of the hub sufficiently to remove the damage or wear. Do not exceed the maximum permitted diameter A or machine below the minimum dimensions D quoted in the relevant table. Maintain dimension C and radii Y and Z. This operation may be carried out indefinitely provided that the maximum permitted diameter A and dimension D are not exceeded.

Magnesium alloy wheels

5. Treat the bare metal with selenious acid solution or if possible, re-chromate. If it is decided to re-chromate stamp the wheel in accordance with para. 8 before re-chromating.

Aluminium alloy wheels

6. Treat the bare metal with Alocrom 1200 as detailed in Vol. 1, Book 1, Sect 1, Chap. 1.

7. The repair must be to the satisfaction of the supervisory Inspecting Authority.

8. After satisfactory completion of the repair impress RP.480 adjacent to the wheel number with $\frac{1}{8}$ in. metal stamps. Protect the impressions with selenious acid solution or Alocrom 1200 as required. If the hub has been re-chromated the RP number will already have been stamped.

9. Assemble the wheel in accordance with Vol. 1, Book 1, Sect. 1, Chap. 1, and the relevant appendix.

RESTRICTED

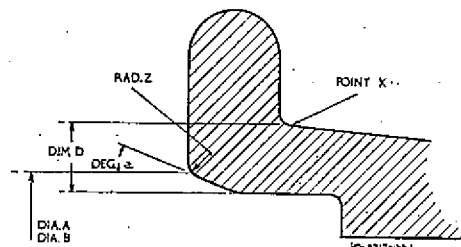

Fig. 1

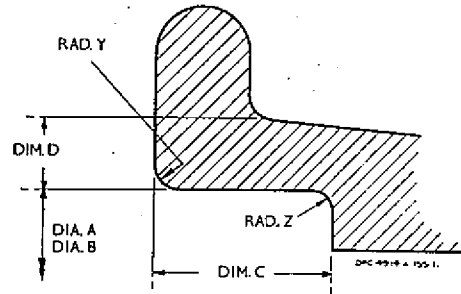

Fig. 2

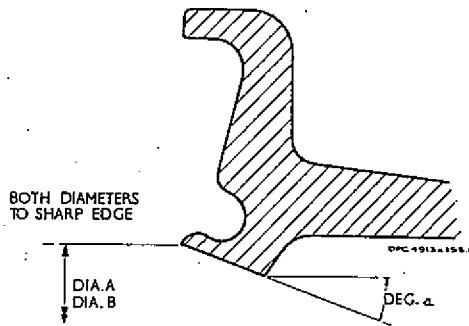

Fig. 3

RESTRICTED !

Whe
No
AH.51

AI
AI

TABLE 1

Refer to fig. 1 for the location of the coded letters

Wheel No.	Hub No.	Diameter A (max.) (in.)	Drawing Dia. B (in.)	Angle a	Dimension D (min.) (in.)	Max. Roll-in (in.)	Radius Z (in.)
AH.51631	AH.41932	15.750	15.687	20 deg.	0.906	0.1 in. dia. at point X	0.030

TABLE 2

Refer to fig. 2 for the location of the coded letters

Wheel No.	Hub No.	Diameter A (max.) (in.)	Drawing Dia. B (in.)	Dimension C (in.)	Dimension D (min.) (in.)	Radius Z (in.)	Radius Y (in.)
AH.50116	AH.40525	13.810	13.750	1.125	0.595	0.187	0.120
AH.51328	AH.41214	14.875	14.812	1.281	0.560	0.250	0.050

TABLE 3

Refer to fig. 3 for the location of the coded letters

Wheel No.	Hub No.	Diameter A (max.) (in.)	Drawing Dia. B (in.)	Angle a
AH.52157	AH.42368	15.762	15.637	20 deg.
AH.51748	AH.42368	15.762	15.637	20 deg.

RESTRICTED

RP.526

REPAIR TO DRIVE BLOCK TENONS
WHEEL, PART No. AH.50945
(Hub, Part No. AH.41251)

Scheme

1. To repair elongated or corroded drive block tenons by fitting drive blocks with integral rivets. Only those tenons which are faulty may be repaired.

2. The following new part is required to carry out this repair:—

Part No.	Description	No. off
AHO.82150	Drive block	As required

Requirements

3. A solution: made from 2 oz. selenious acid crystals dissolved in one pint of water. Pigmented oil varnish jointing compound D.T.D.369.

Examination

4. Examine the drive blocks in situ. If corrosion is present, without elongation, remove it by blasting the drive blocks without stripping them from the hub. If a drive block housing is elongated it must be repaired as follows.

Method of repair

5. (1) Dismantle and degrease the wheel.
- (2) Drill out the old rivets from the relevant half hub and remove the drive blocks from the faulty tenons.
- (3) Remove all corrosion by vapour blasting.
- (4) Machine and drill the faulty tenons to the details given in fig. 1.

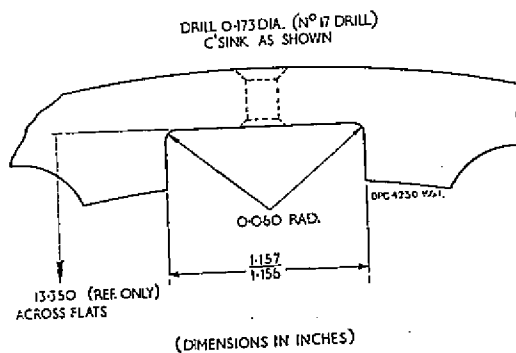
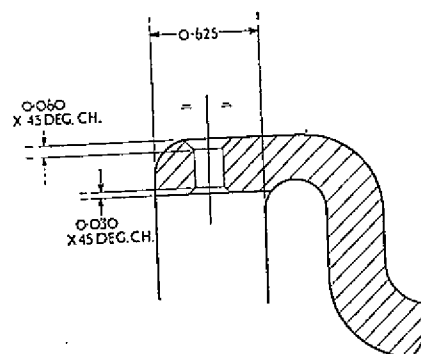

Fig. 1. Drilling and machining the tenons

- (5) Clean the repaired surfaces and coat them with selenious acid solution or if possible re-chromate them. If the wheel is to be re-chromated, stamp "RP.526" in $\frac{1}{8}$ in. metal stamps adjacent to the part number of the half hub before chroming.

RESTRICTED

(6) Coat the mating surface of each new drive block with pigmented oil varnish jointing compound D.T.D.369; ensure a generous fillet at all mating surfaces, and then rivet it to the half hub (fig. 2).

6. The repair must be to the satisfaction of the supervising inspector A.I.D., C.I.O.,/ N.A.I. or C.I.O./A.I.S.

Identification

7. After satisfactory completion of the repair use $\frac{1}{8}$ in. metal stamps to impress RP.526 as detailed in 5(5); if the wheel has been re-chromated it will already have been stamped. Protect the indentations with selenious acid solution.

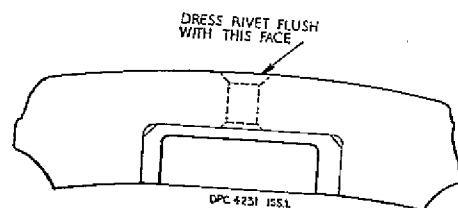
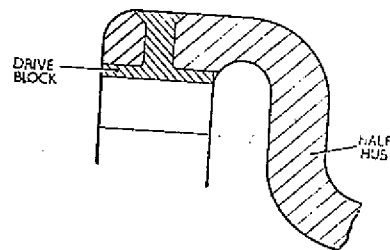

Fig. 2. Riveting the drive blocks

RESTRICTED

F.S./1

RP.541
REPAIR TO DRIVE BLOCK
RETAINING HOLES
Wheel, Part No. AH.9729
(Hub, Part No. AH.40174)

Scheme

1. To repair stripped threads in the wheel hub drive block retaining holes.

New part

2. The following new part is required to carry out this repair:—

Part No.	Description	No. off
S.25020	Tappex insert	As required

Requirements

3. Selenious acid solution: Make from 2 oz. selenious acid crystals dissolved in one pint of water.

Special tools

Part No.	Description	No. off
WHD.25020	Tappex driver	1
AHO.82368	Bush	1
A.5927 and A.5926	Drill jig and foot	1

Method of repair

4. (1) Dismantle and degrease the wheel.
- (2) Drill the faulty holes to the details given in fig. 1. Treat the bare metal with selenious acid solution.
- (3) Assemble the drill jig and foot, the bush, the Tappex driver and the Tappex

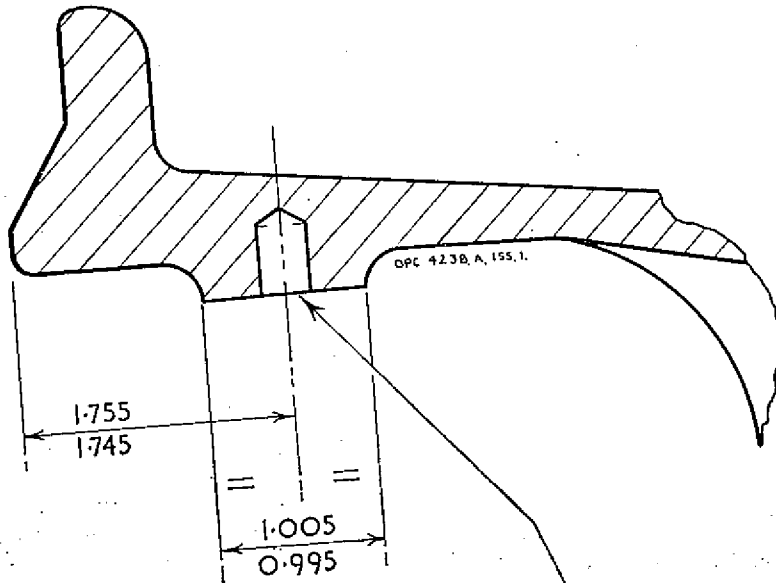

DRILL HOLES AS SHOWN 0.353/0.343 DIA.
(LETTER 'S' DRILL) X 0.450 DEEP TO SHOULDER

(DIMENSIONS IN INCHES)

Fig. 1

RESTRICTED

SECTION 2

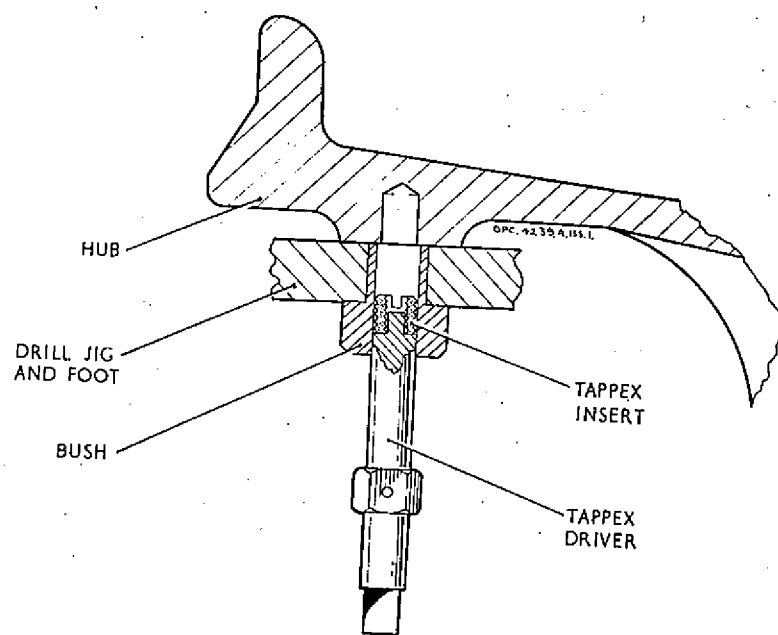

Fig. 2

- insert as shown in fig. 2. Carefully line-up the insert and then drive it clockwise into the hub.
5. The repair must be to the satisfaction of the supervisory Inspecting Authority.

Identification

6. With $\frac{1}{8}$ in. metal stamps impress RP.541 adjacent to the part number of the wheel. Protect the indentations with selenious acid solution.

RESTRICTED

RP.595
REPAIR TO BEARING HOUSING
WHEEL, PART No. AH.51748
(Hub, Part No. AH.42368)

1. This repair scheme is to fit an oversize steel bearing housing to the hub, thus converting the wheel to AH.52157, or to replace a worn bearing housing on wheel AH.52157.

2. The following new parts are required

Part No.	Description	No. off
AHM.6268	Bearing housing	1
AHO.82800	Bolt	10
AHO.36038	Washer	10
AHO.36037	Nut	10

3. Other requirements are a selenious acid solution, made from 2 oz. selenious acid crystals dissolved in one pint of water, and Araldite D.T.D.900/4365 and Hardener D.T.D.900/4440.

Method of repair

4. (1) Dismantle the wheel in accordance with A.P.2337, Vol. 1, Book 1, Sect. 1, Chap. 1.
- (2) Remove the nuts, bolts and washers securing the old bearing housing to the hub.
- (3) Remove the paint, if necessary, and degrease the wheel.
- (4) Heat the hub to 150 deg. C by placing it in a muffle furnace, then remove the bearing housing.
- (5) Set up the hub in a lathe so that the chuck jaws locate on the loose flange side of the rim. The hub must run true in both the vertical and horizontal planes. To check for truth apply a dial test indicator to the hub bore. The maximum permitted d.t.i. variation is 0.002 in.
- (6) Machine the bore to the details given in Fig. 1.
- (7) Clean the machined surfaces and apply selenious acid solution or if

possible re-chromate (refer to para. 6). Heat the hub to 150 deg. C. Coat the bore of the hub and the mating faces of the bearing housing with the Araldite and Hardener. Line up the bolt holes carefully and press in the bearing housing. Check that a 0.0015 in. feeler gauge cannot be inserted between the bearing housing flange and the hub.

(8) After cooling, ream out the bolt holes through the hub and sleeve to 0.454 in./0.453 in. dia. on a 7.5 p.c. dia.

(9) Protect the machined surfaces with selenious acid solution.

(10) Secure the sleeve to the hub with the new bolts, nuts and washers. Tighten the nuts to a torque loading of 40 lb ft (greased). Lock by peening the ends of the bolts into both slots in the nuts.

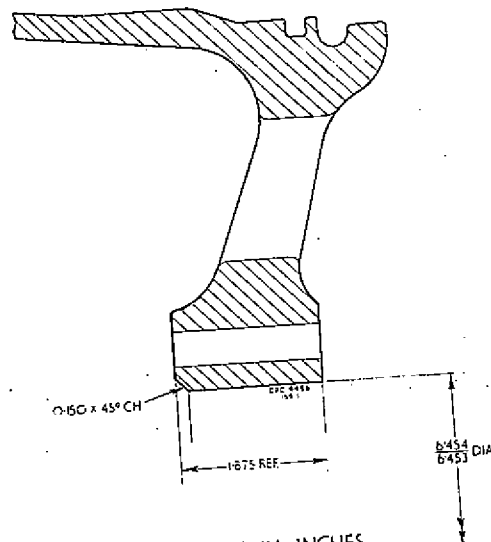

DIMENSIONS IN INCHES

Fig. 1

RESTRICTED

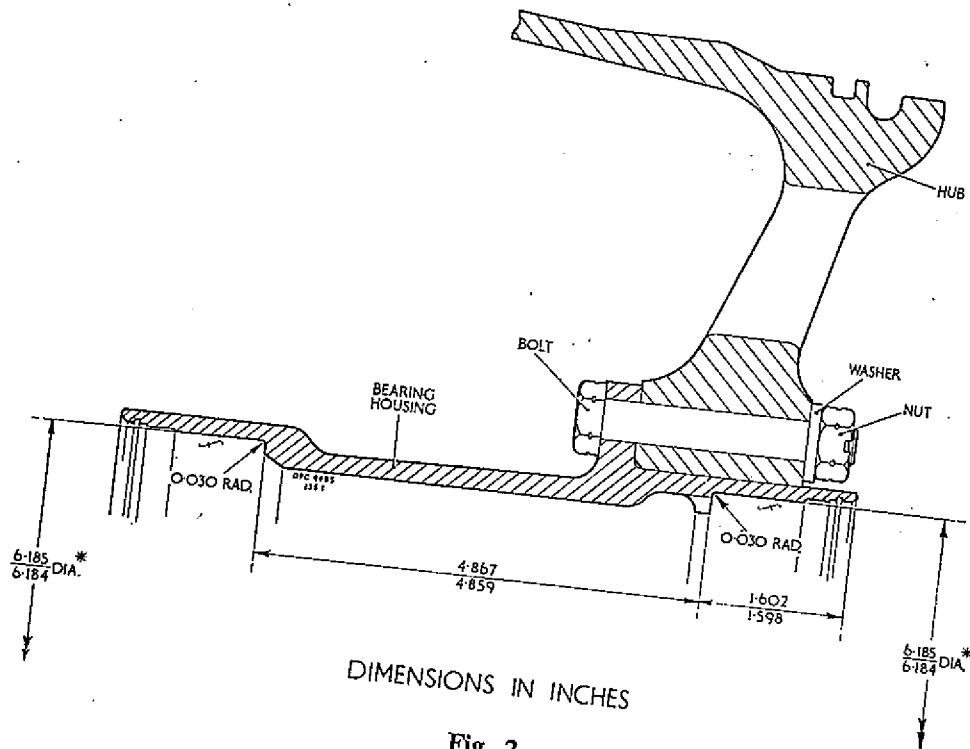

Fig. 2

- (11) Machine the bearing liner to the details given in Fig. 2. Machine at f only. Diameters marked * must be concentric with the outside diameter to within 0.002 in. total indicator reading.
- (12) Remove the swarf and protect the exposed metal with grease.
5. The repair must be to the satisfaction of the supervisory Inspecting Authority.
6. After satisfactory completion of the repair impress RP595 on the face of the wheel adjacent to the wheel number with $\frac{1}{8}$ in. metal stamps. If the hub is to be re-chromated, stamp the RP number before re-chromating. If this repair scheme has been undertaken to convert wheel Part No. AH.51748 to wheel Part No. AH.52157, the old identification must be obliterated and the wheel re-identified as AH.52157.
7. If necessary re-paint in accordance with Vol. 1, Sect. 1, Chap. 1.
8. Re-assemble the wheel in accordance with Vol. 1, Book 1, Sect. 1, Chap. 1, and App. 120.

This file was downloaded
from the RTFM Library.

Link: www.scottbouch.com/rtfm

Please see site for usage terms,
and more aircraft documents.

