

## CHAPTER 4

### RADIO

#### LIST OF CONTENTS

	<i>Para.</i>		<i>Para.</i>
General ... ..	1	Using the transmitter ... ..	8
Whip aerial ... ..	2	Unfavourable kite-flying conditions ... ..	9
Kite aerial ... ..	3	Signalling lamp, Type M-308 ... ..	10
Launching the kite ... ..	6	Using the receiver ... ..	11
Setting up instructions (kite aerial)	7	Communication ... ..	12
		T.3180 (Walter) ... ..	16

#### LIST OF ILLUSTRATIONS

	<i>Fig.</i>
Radio installation, wiring diagram... ..	1
Switch unit ... ..	2
Transmitter, Type BC-778 ... ..	3
Receiver, Type R.1545 ... ..	4
Transmitter, Type T.3180 (Walter) ... ..	5

#### General

1. It should be borne in mind that radio signals are a means whereby aircraft, or surface craft, can home on the lifeboat. Transmitter, Type T.3180 (Walter), a radar oscillator for homing purposes only, is stowed in protective bags in No. 3 port stowage compartment, and a hand-generator transmitter, Type BC-778, which operates only on the International Distress Frequency of 500 kcs., and is capable of transmitting an automatic signal, or which can be key-operated, as desired, is stowed together with a receiver, Type R.1545, beneath the forward self-righting chamber on the port side of the deck. The BC-778 transmitter has a normal range of 100 miles approximately, when used in conjunction with the kite aerial, although, under favourable conditions, signals have been received at distances in excess of 300 miles. The radio wiring installation is illustrated in fig. 1.

#### Whip aerial

2. When unfavourable weather conditions prohibit a kite from being launched and so preclude the use of the kite aerial, use can be made of the standby whip aerial attached to the mast head. With the whip aerial connected, the range of the BC-778 transmitter is reduced to 25 miles approximately; it is preferable, therefore, weather conditions permitting, to launch a kite and use the kite aerial.

#### Kite aerial

3. Kites and flying lines are stowed in No. 3 starboard stowage compartment. The kite should be launched in accordance with the instructions printed on it and also given in para. 6.

**R E S T R I C T E D**

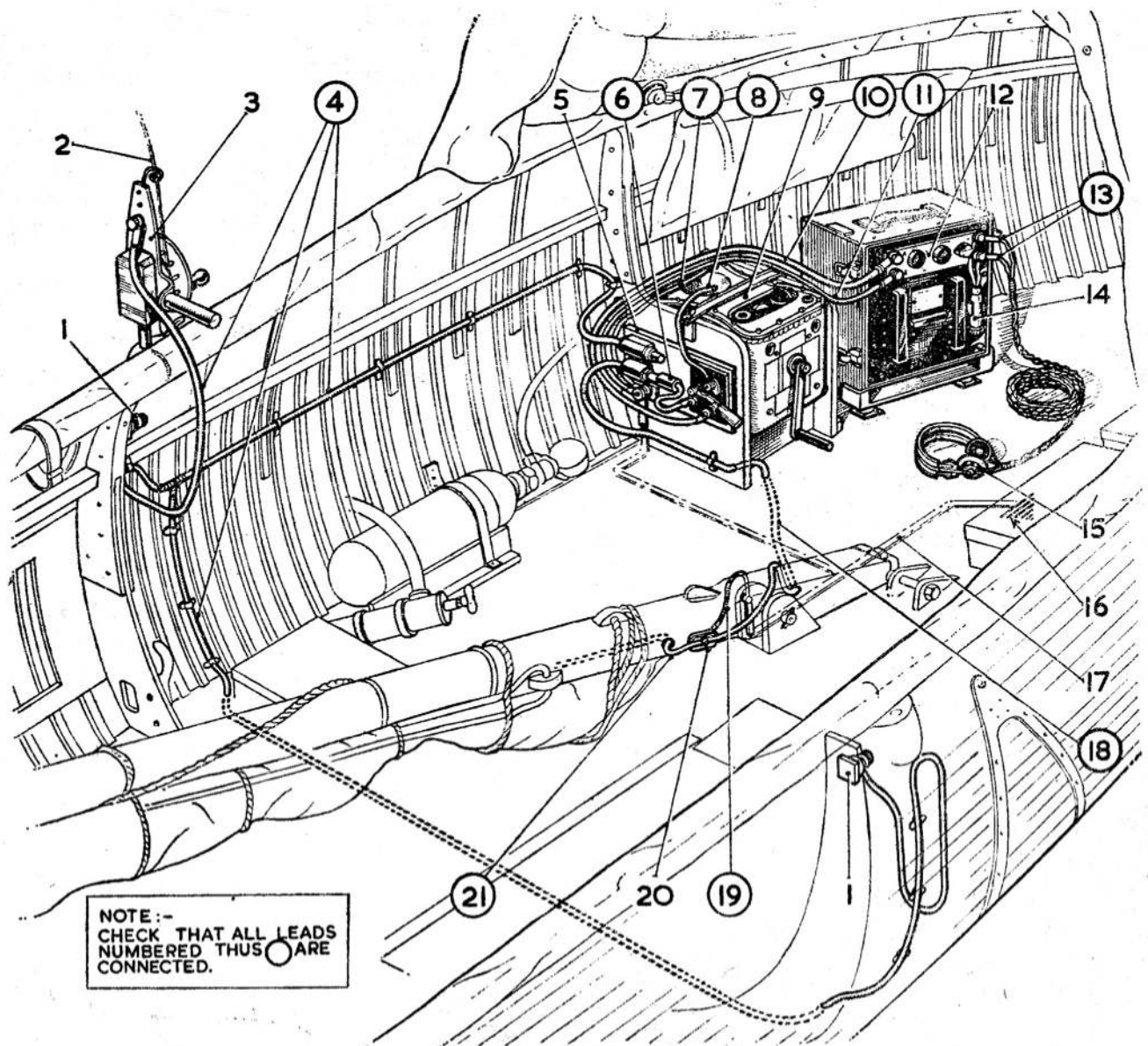

- |    |                                       |    |   |
|----|---------------------------------------|----|---|
| 1  | INSULATED STOWAGE TERMINAL            | 13 | TELEPHONE TERMINALS                         |
| 2  | AERIAL SYSTEM, TYPE 411 (KITE AERIAL) | 14 | INTERCOMM. SOCKET                           |
| 3  | AERIAL WINCH, TYPE 10                 | 15 | TELEPHONES                                  |
| 4  | KITE AERIAL LEADS                     | 16 | EARTH PLATE (BELOW DECK)                    |
| 5  | SWITCH UNIT, TYPE 188                 | 17 | BONDING SYSTEM (BELOW DECK)                 |
| 6  | AERIAL CHANGE-OVER SOCKET             | 18 | WHIP AERIAL LEAD (CONDENSER TO SWITCH UNIT) |
| 7  | TRANSMITTER EARTH LEAD                | 19 | CONDENSER EARTH WIRE                        |
| 8  | TRANSMITTER AERIAL LEAD               | 20 | CONDENSER, TYPE 126                         |
| 9  | TRANSMITTER, TYPE BC-778              | 21 | WHIP AERIAL LEAD (CONDENSER TO WHIP AERIAL) |
| 10 | RECEIVER AERIAL LEAD                  |    |   |
| 11 | RECEIVER EARTH LEAD                   |    |   |
| 12 | RECEIVER, TYPE R.1545                 |    |   |

FIG. I. RADIO INSTALLATION, WIRING DIAGRAM

**RESTRICTED**

4. Before an attempt is made to launch a kite, it is advisable to strike the mainsail and bring the lifeboat round until the wind is on the beam; it will be found that, by making use of the foresail and the tiller, the lifeboat can be brought to lie across wind.

5. An aerial winch, Type 10, on which is wound an aerial system, Type 411, is stowed in No. 2 stowage compartment. When it is desired to use the kite aerial, the winch should be removed from its stowed position, mounted in the socket of the forward rowlock block on the lee side of the lifeboat, and connected to the switch unit as described in para. 7.

#### Launching the kite

6. The kite should be launched as follows:—

- (1) Remove the lid of the container, and withdraw the cardboard box which contains the flying line. One end of the flying line is attached to the top bridle point of the kite by a snap-hook, and the other end is clipped inside the container lid.
- (2) Withdraw the kite from its container, in which it is stowed in two sections, and remove the rubber bands from the fabric. Assemble the four main longerons by inserting the tube ends into their corresponding halves, commencing with the tubes located by a registering cord.
- (3) Develop the kite by holding one of the longerons and shaking the kite partially open. Press outward on the spiders at each end until the spreading members seat in their outward position which is slightly beyond dead-centre. The kite is now ready to be launched.
- (4) If the wind speed is less than 20 m.p.h., the flying line snap-hook is to be removed from the top bridle point and attached to the bottom bridle point of the kite.

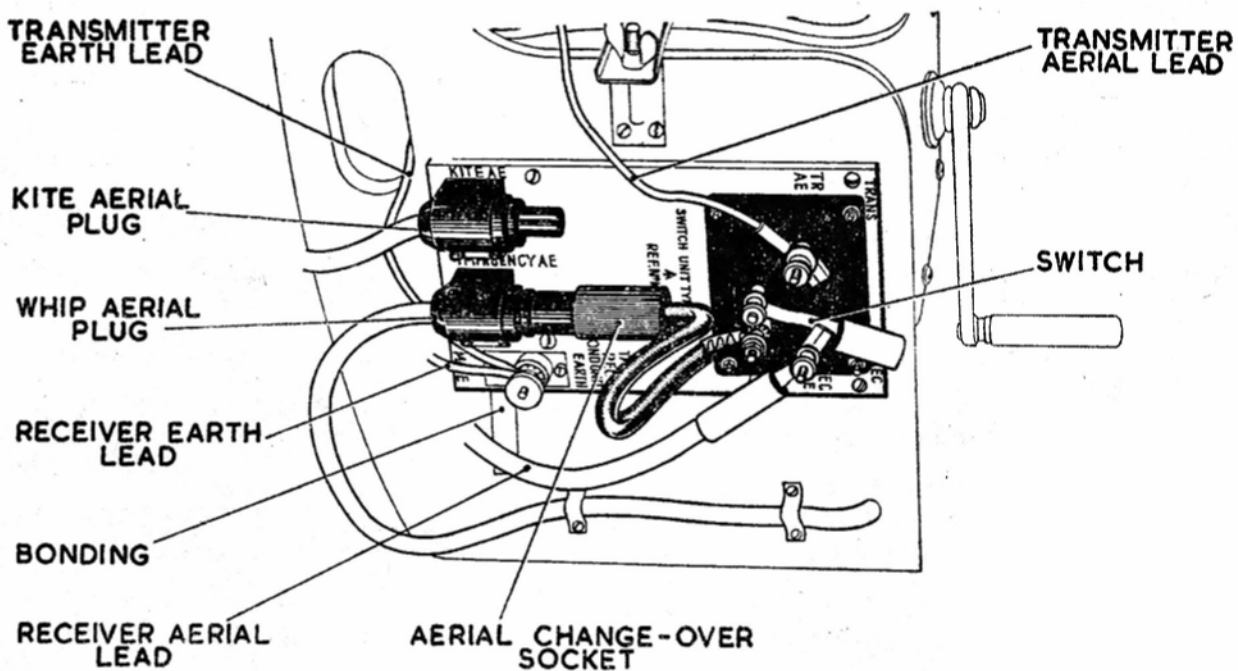

FIG. 2. SWITCH UNIT

**R E S T R I C T E D**

- (5) Launch the kite by hand, on the lee side of the lifeboat, pay out the flying line gently until it is withdrawn completely from its cardboard box. Detach the cardboard box by pulling off the adhesive tape.
- (6) Disconnect the metal ring, on the inboard end of the flying line, from the spring clip inside the container lid, attach the ring to the aerial clip, and allow the kite to take up the aerial (para. 7).

#### Setting up instructions (kite aerial)

7. The kite aerial system should be set up in the following manner:—
  - (1) Assemble and launch the kite in accordance with the instructions printed on it and also given in para. 6.
  - (2) Attach the spring clip on the end of the aerial to the ring on the end of the flying line if this has not been done already.
  - (3) Pay out the aerial wire slowly until all but two turns of wire have left the drum of the winch. The brake, situated below the drum of the winch, controls the speed at which the aerial is paid out.
  - (4) Connect the aerial winch to the switch unit for the transmitter and receiver; to do this, detach the end of the appropriate aerial lead from its position on the insulated stowage terminal below the lee gunwale, and attach it to the terminal on the aerial winch (fig. 1). Ensure that the unused lead, on the windward side of the lifeboat is secured to its insulated stowage terminal.

#### **WARNING**

All metal parts of the aerial winch are live when the transmitter is being used, and, for this reason, care must be taken to prevent contact between the winch and any part of the body, or with wet parts of the lifeboat. This warning is particularly applicable to the brake of the winch.

- (5) The switch unit (fig. 1 and 2), which is situated on the port gunwale knee, aft of the transmitter, carries a plug which is marked KITE AE, and the aerial change-over socket, on the end of the short switch cable, is to be pushed home firmly on this plug.

#### Using the transmitter

8. When it is desired to operate the BC-778 transmitter (fig. 1 and 3), the following procedure should be adopted:—

- (1) Place the switch lever, on the switch unit, to the position marked TRANS.
- (2) Set the selector switch, on the top of the transmitter case, so that the word RADIO, on the knob, appears opposite the word MANUAL on the transmitter case.
- (3) Rotate the handle of the transmitter in a clockwise direction, increasing speed until the SPEED INDICATOR, on the left-hand top corner of the inboard end of the transmitter case, is illuminated; no advantage is obtained by exceeding this speed.
- (4) Another member of the crew is to press down the manual key, on the top of the transmitter case, left-hand side, and is to hold it in this position.
- (5) Rotate the handle at the correct speed for 25 seconds, and then turn the TUNE control, on the top of the transmitter case, until the maximum amount of light is seen in the

**R E S T R I C T E D**

unit, and press it home firmly on the plug marked EMERGENCY AE; ensure that the aerial leads, one of which emerges from the deck, near the port side of the mast foot, and the other from the starboard side of the mast, are connected to the terminal on the condenser unit on the starboard side of the mast, and that the condenser earth wire is connected to the terminal on the port lug of the mast tabernacle. The transmitter and the receiver will both require to be re-tuned when the standby whip aerial is brought into use, and again, when it is desired to revert to the kite aerial system.

### Signalling lamp, Type M-308

10. A small signalling lamp, Type M-308-A or B, is stowed in No. 2 stowage compartment. If it is desired to employ this lamp to communicate with aircraft or surface craft, the procedure is as follows:—

- (1) Insert the 2-pin plug, on the end of the signalling lamp lead, into the socket in the right-hand corner of the top of the transmitter case, and focus the lamp on the target.
- (2) Set the selector switch on the top of the transmitter case, so that the word LIGHT, on the knob, appears opposite the desired position, and rotate the handle of the transmitter. When the MANUAL setting is selected, the manual key is to be used; but when the AUTO 1 or AUTO 2 setting is used, the lamp will flash intermittently (some of the later transmitters give a continuous light in both the AUTO settings).

#### **Note . . .**

(a) It is not necessary to have either aerial system connected to the transmitter when the signalling lamp is being used.

(b) The transmitter is inoperative for radio purposes when the selector switch is in one of the LIGHT settings.

### Using the receiver

11. The following procedure should be adopted when it is desired to operate the receiver (fig. 1 and 4):—

- (1) Remove the lid of the container, and attach the thick aerial lead to the aerial terminal on the left-hand upper corner of the front of the receiver.
- (2) Attach the earth lead (marked E) to the earth terminal, directly below that for the aerial lead.
- (3) Connect the telephones to the terminals on the right-hand upper corner of the front of the receiver, above the intercomm. socket.
- (4) Place the switch lever of the switch unit, which is situated on the forward gunwale knee on the port side of the lifeboat, to the position marked REC.
- (5) Set the SWITCH knob, on the front of the set to its ON position.
- (6) Turn the TUNING knob to 500 on the scale.
- (7) Rotate the REACTION knob fully in an anti-clockwise direction.
- (8) Turn the REACTION knob slowly in a clockwise direction until a rushing noise is heard in the telephones; this noise indicates that the receiver is oscillating.
- (9) With the REACTION knob in this position, searching is to be commenced by rotating the TUNING knob from 470 to 530, and then from 530 back to 470 as shown on the scale.

**R E S T R I C T E D**

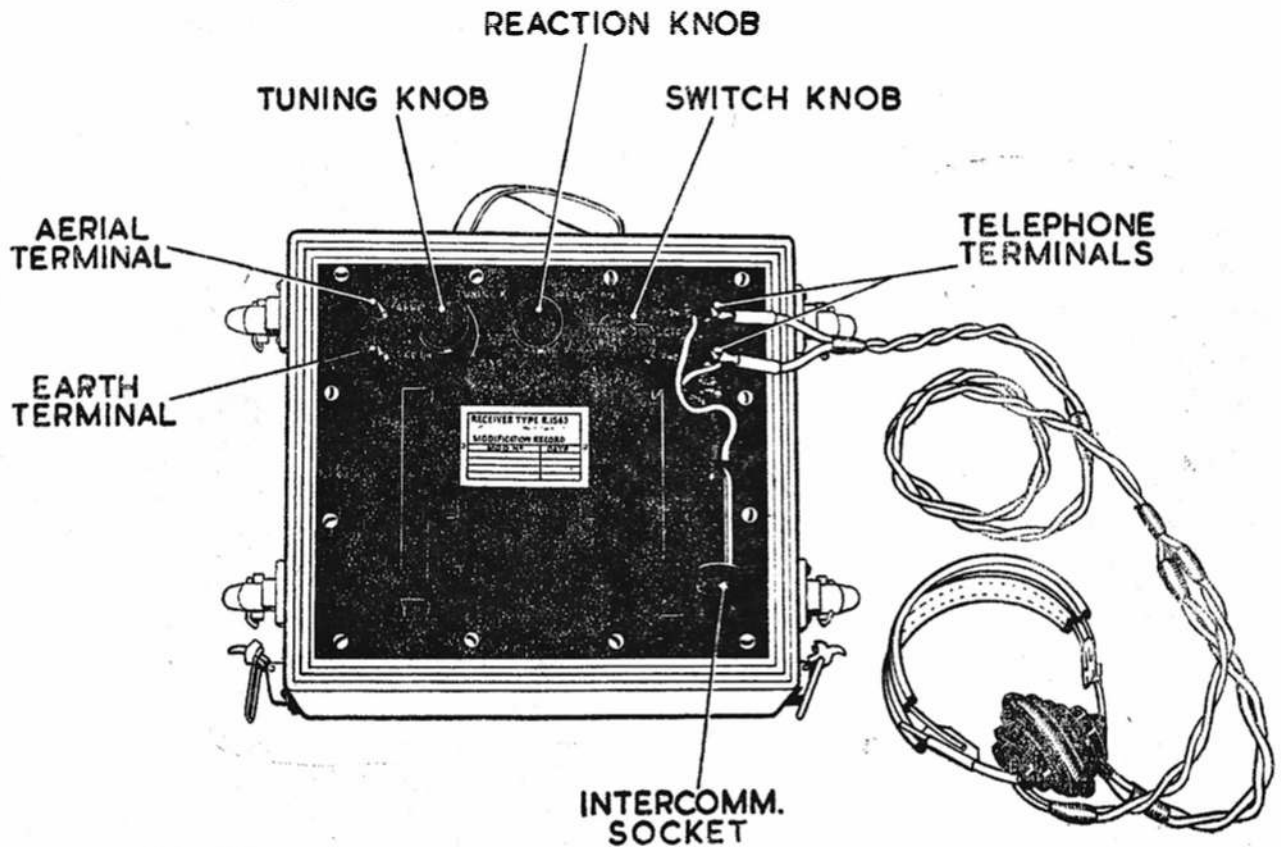

FIG. 4. RECEIVER, TYPE R.1545

A whistling noise will probably be heard in the telephones, and this noise will increase and decrease in pitch as the knob is rotated.

- (10) With the TUNING knob turned to the position at which the whistling noise is most intense, rotate the REACTION knob slowly in an anti-clockwise direction until the whistling noise becomes intelligible as a signal. If the signal so received is not the one desired, the searching procedure should be repeated and is to be continued for the period stipulated (para. 13), or until the desired signal is received; when this occurs, the exact position on the tuning scale is to be noted, and the listening watch can then be maintained without further searching.

**Note . . .**

(a) If it is desired to use a flying-helmet telephone set with the receiver, it is to be plugged into the intercomm. socket on the front of the receiver; but, if this is done, the telephone supplied with the receiver, must be disconnected at the terminals above the intercomm. socket, as only one set of telephones should be connected to the receiver at any one time. Ensure that the wires from the intercomm. socket are connected to the telephone terminals on the front of the receiver.

(b) The receiver operates from power supplied from storage batteries contained in the set, and, as the size of these batteries is limited of necessity, it is important that the receiver should be used only with the strictest economy. To conserve battery power, the SWITCH knob must always be turned to the OFF position as soon as the listening

**R E S T R I C T E D**

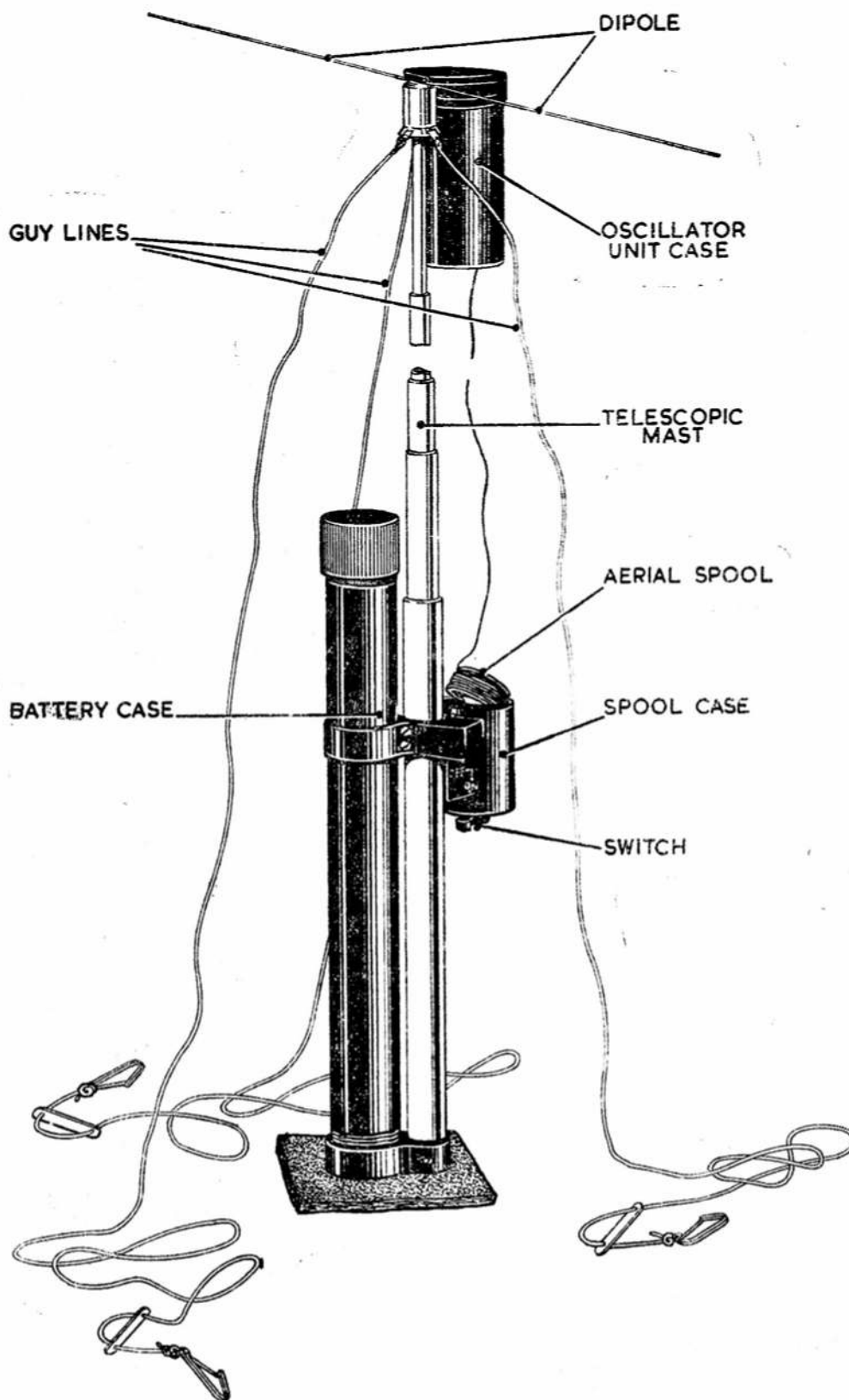

FIG. 5. TRANSMITTER, TYPE T.3180 (WALTER)

**R E S T R I C T E D**

This file was downloaded from the RTFM Library.  
Link: [www.scottbouch.com/rtfm](http://www.scottbouch.com/rtfm)

Please see site for usage terms, and more aircraft documents.

