

CHAPTER 7

GAS TURBINE ENGINE STARTING SYSTEMS

Objectives

1. When you have studied this Chapter, you should be able to satisfy the objectives listed in the relevant Skill and Knowledge Specifications (SAKS) for your trade in this subject area. In particular you should be able to:
 - a. State the need for a starter in a gas turbine engine.
 - b. State the need for correct sequencing and timing of the events during the starting cycle.
 - c. List the types of gas turbine engine starters in use and explain, in outline, the broad principles of operation of each.
 - d. State the safety precautions involved in starting—in particular, when operating cartridge type starters and in handling iso-propyl-nitrate (IPN) liquid fuel.
 - e. Explain how ignition is achieved in gas turbine engines.

Introduction

2. To start a gas turbine engine, it is necessary to:
 - Rotate the engine shaft up to a speed that provides an adequate airflow; this is achieved by using a starter motor.
 - Provide fuel to mix with the airflow to provide a correct mixture for combustion.
 - Ignite the air/fuel mixture; a high energy ignition system is used to provide this.
3. **Need for a starter.** Before it is safe to ignite fuel in the combustion chamber, the engine main shaft must be revolving at a speed which enables the compressor to provide an adequate airflow through the engine. The airflow must be sufficient to mix with the atomized fuel at the burners and to sustain ignition; it must also provide adequate cooling to protect the engine during the 'light-up' period. Some form of starter motor is necessary to spin the engine shaft up to the required self-sustaining speed. Various types of starter motors are used in practice (see later).
4. **Ignition.** Having induced the required airflow through the engine to mix with the fuel, we must now provide a means of igniting the mixture to cause the engine to run under its own power. This is usually achieved by an electrical high energy spark which takes place at the igniter plugs in the combustion chamber(s) and 'lights' the fuel as it is sprayed from the burners. Just as in a piston engine, the 'light-up' will be successful only if ignition occurs at the correct instant in time—*ie* when all the necessary conditions are satisfied. This is achieved by having an electrical starting circuit, containing timing and switching devices, to ensure the correct sequencing and timing of events. The starting cycle is automatic once a start has been initiated by pressing the starter button.

BASIC ENGINE STARTING SYSTEM

Starting Cycle

5. It must be clearly understood that a starter motor is merely a means of spinning the rotating assembly of the engine up to the required speed and that it is only one component in the engine starting system. The starting cycle is controlled by a start master switch and a sequence control unit.

The electrical circuits must also include a means of energizing the engine ignition system without the use of the starter motor. This is called the 're-light' circuit and is intended for re-starting an engine in flight; but it can also be used on the ground to test the operation of the high energy ignition system (see later).

Starting Circuit

6. The electrical circuit supplying the services for starting a gas turbine engine varies from one aircraft to another and is governed by the starting requirements. Detailed knowledge of the starting circuit and its servicing are the responsibility of the electrical tradesman and need not concern you to any great extent. However, some background knowledge of the sequence of events in a starting cycle are relevant and are considered below.

7. Fig 2.7.1 illustrates an example of the switching and time delays applicable to the starting circuit of the Viper engine installed in the Jet Provost. In this engine, an electric motor is used to drive the aircraft gas turbine engine. Remember however, that the type of starter used, the circuits being switched, and also the various time delays involved vary considerably from one aircraft type to another. For information on a particular aircraft starting system consult the appropriate aircraft AP.

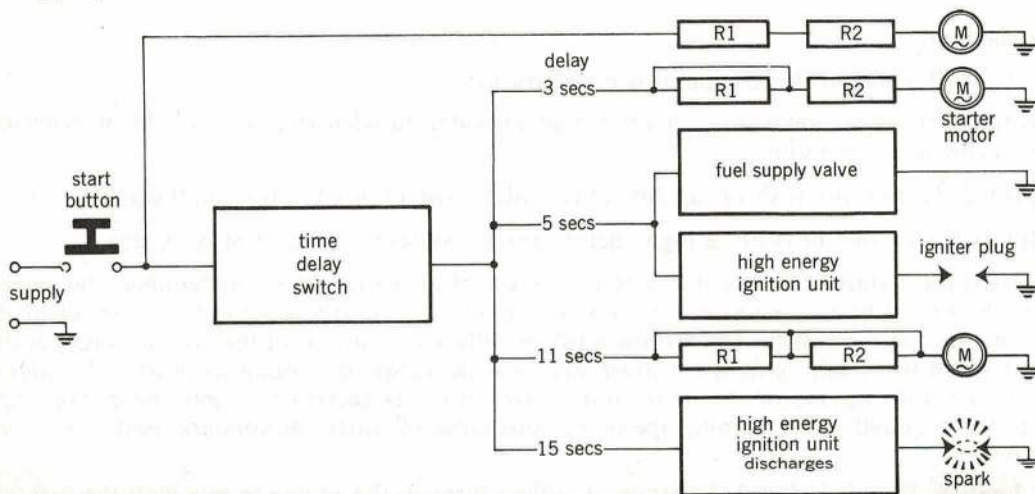

Fig 2.7.1 Example starting cycle

8. Fig 2.7.1 shows the following sequence:

- On pressing the starter button, current is applied from the supply to:
 - The electric starter motor through two series resistors R1 and R2, which reduce the current to the motor and, consequently, its initial speed.

- The time delay switch, which controls the sequencing and timing.
- After a delay of 3 seconds, R1 is short-circuited, the current to the motor increases and the motor speeds up.
- Five seconds after pressing the starter button, current is supplied to:
 - A fuel supply valve, which operates to provide a supply of fuel to the engine.
 - The high energy ignition unit which begins to charge.
- At 11 seconds, resistor R2 is short circuited and the motor speeds up to its maximum speed. This is such that the airflow through the gas-turbine engine produces the required fuel/air mixture.
- At 15 seconds, the high energy ignition unit discharges across the gap of the igniter plugs (situated in the engine combustion chamber) and ignition takes place.
- At 35 seconds, the start contacts open to release the starter button and de-energise the starter motor. The time delay switch will continue to run until the contacts return to the original pre-start positions.

Engine Starter Motor

9. In the example just discussed, an electrical motor was used to 'crank' the gas-turbine engine. In fact, one of a number of methods may be used. Fig 2.7.2 shows that gas-turbine engine starters are in one of the following groups:

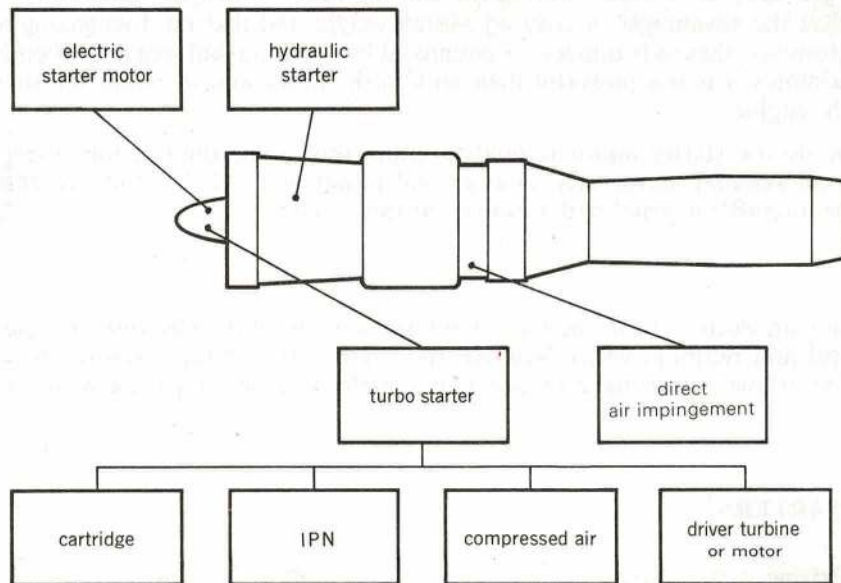

Fig 2.7.2 Starters for gas-turbine engines

- Electric starter motors.
- Turbo-starter motors, in which the energy required to drive the turbo-starter is derived from one of the following:

- Explosive cartridge.
- Iso-propyl-nitrate (IPN) fuel.
- Compressed air.
- A 'driver' (either a smaller gas turbine engine or an electric motor).
- Direct air impingement into the aircraft's engine turbine blades.
- Hydraulic starter.

We shall consider each of these in turn in the following paragraphs.

ELECTRIC STARTER MOTOR

Principle

10. Early types of gas turbine engines were small and, in general, employed an electric motor to spin the engine shaft during the starting cycle. The electric starter is usually a direct current (dc) motor coupled to the engine shaft through a reduction gear and a ratchet-mechanism or other automatic disengaging drive. The electric motor suffers from the disadvantage that it cannot accelerate the engine to self-sustaining speed as quickly as many other types of starting mechanisms.

Some engines use a separate electric motor for starting, whereas others may use the aircraft dc generator as a motor during the starting cycle. When the generator is used as a motor it offers the advantages of reduced overall weight and that no disengaging mechanism is needed. However, these advantages are countered by the disadvantages that when a generator is used as a motor it is less powerful than an electric motor and increases the time taken to accelerate the engine.

When an electric starter motor is used to crank the engine the starting current must be supplied by an external source such as a 'ground power unit' (GPU); this prevents excessive strain on the aircraft's internal batteries and ensures a start.

Servicing

11. Servicing an electric starter motor is the responsibility of the electrical tradesman. Apart from removal and refitting, when required, the engine fitter should examine the starter for security of attachment and make certain that the electrical leads are clean, serviceable and secure.

TURBO STARTERS

Method of Driving

12. A turbo-starter consists of a small high-speed turbine which, as we saw in Fig 2.7.2, may be driven by:

- The gases from an explosive cartridge.
- The exhaust gases from a burning liquid fuel (IPN).
- Compressed air from an external source, such as the auxiliary airborne power plant (AAPP) in the aircraft, or from the compressor of a running engine.

- A small 'driver' gas turbine or electric motor.

Cartridge Turbo-Starter

13. **Principle.** This starter system is entirely self-contained and requires no connection to an external power source. The starter motor is, basically, a small impulse type turbine which is driven by the powerful gases of an explosive cartridge (Fig 2.7.3). The cartridge is fired electrically and the gases developed by the explosion are used to rotate the engine *via* a reduction gear and an automatic connect/disconnect mechanism. The cartridge burns for approximately two seconds and is capable of driving the starter motor at 40 000 rev/min, at which speed safety devices are introduced to prevent overspeeding. The pressure of the explosive gas is controlled by a system of relief valves.

14. **Construction.** When loaded, the starter houses three cartridges, enabling three starting attempts to be made before reloading is necessary. Described as a 'triple breech' starter, the assembly consists of three sub-units:

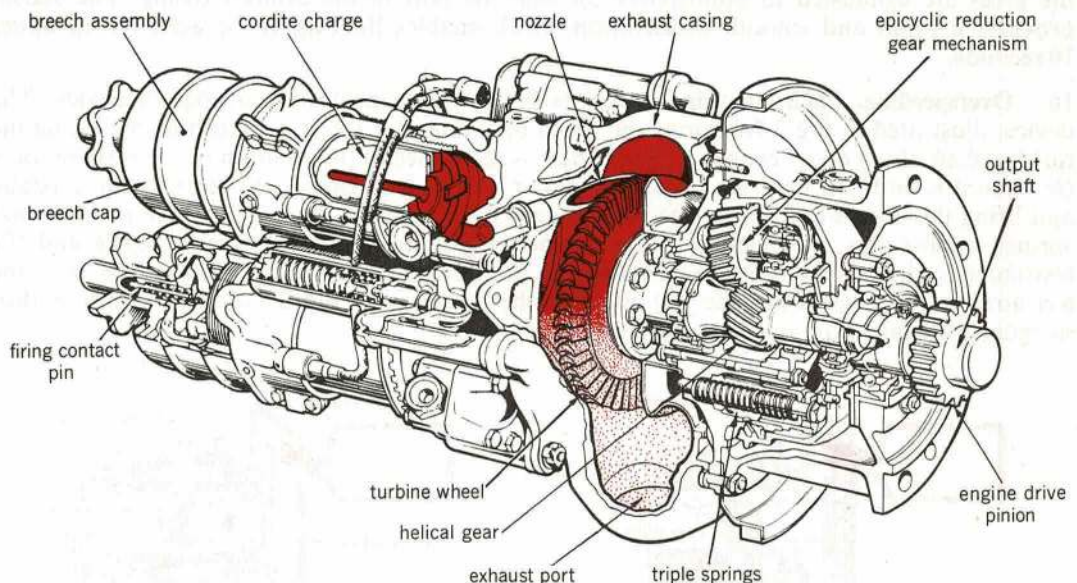

Fig 2.7.3 Triple breech turbo-starter

- **Turbine and reduction gear mechanism.** The turbine and reduction gearing are housed in a single casing which is bolted to the starter mounting face of the engine. The turbine shaft has an integral helical gear and can move end wise in its bearings against a triple spring loading; the turbine is mounted on a flange at one end of the shaft. The helical gear forms the sun wheel of the epicyclic reduction gearing and transmits the power to the engine through the output shaft.
- **Exhaust casing.** The exhaust casing separates the turbine assembly from the breech mechanism. A heat-resisting steel casting, it forms a large exhaust chamber with three equally-spaced exhaust ports at its outer edge.
- **Breech assembly.** Three breech mechanisms of identical design are arranged symmetrically around the gas inlet casing which is attached to the front of the exhaust casing. The axes of the breech mechanism lie parallel to the centre line of the starter. Each mechanism consists

of a cartridge barrel, a pressure relief valve, and a pair of gas discharge nozzles that lead into the turbine chamber. A breech cap holds the cartridge in the barrel; it screws on to the forward end of the barrel and seats on a rubber ring to form a watertight seal. When the breech cap is screwed home, a firing pin in the centre of the cap is connected to the electrical system through a slip ring and spring contact. When the starter is loaded, the firing pin is in contact with an electrically operated primer in the centre of the base of the explosive cartridge. There are two pairs of spring-loaded claws in the breech cap: one pair mates with the serrations on the barrel to form a cap-locking device, which is released by hand pressure on the centre plunger of the cap; the other pair of claws fits over the base flange of the cartridge and automatically extracts the cartridge as the breech cap is unscrewed.

15. **Operation.** The cartridge to be fired is selected automatically by a firing selector switch in the cockpit. When the cartridge is fired, the explosive gases, at tremendous pressure, pass swiftly through the two discharge nozzles into the turbine housing. The convergent/divergent nozzles direct the high pressure gas on to the turbine rotor blades causing it to turn at high speed and, *via* the reduction gear, turn the engine for starting. On leaving the turbine blades, the gases are exhausted to atmosphere through the port in the exhaust casing. The starter provides a rapid and smooth acceleration which enables light-up to be achieved in under 10 seconds.

16. **Overspeeding.** Each cartridge starter is fitted with a protective overspeed device. The device, illustrated in Fig 2.7.4, limits the speed of rotation of the starter turbine by sliding the turbine shaft along its bearings. When there is resistance to the rotation of the turbine rotor (*ie* when it is on load) the helix angle of the gear on the shaft causes the shaft to move axially and bring the blades directly in line with the gas nozzles, as in Fig 2.7.4a; three compression springs oppose this movement. As the engine speeds up during the starting cycle and the resistance to the turbine rotation decreases, so the springs move the rotor out of line with the gas nozzles and away from the full effect of the gas stream (Fig 2.7.4). The starter is thus safeguarded against overspeeding of the turbine.

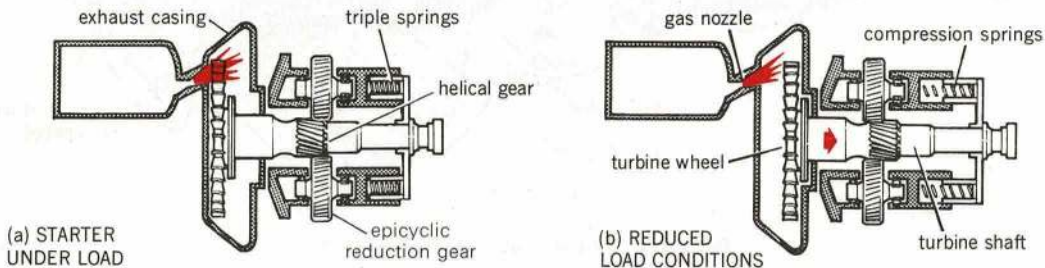

Fig 2.7.4 Overspeeding device

17. **Loading.** Before any attempt is made to load the starter with cartridges, two important checks are necessary. First, that the electrical supply is 'OFF' and, secondly, that the breeches are clean and dry (particularly their electrical contacts). Once these conditions are assured, proceed as follows:

- Depress the central plunger in the breech cap and unscrew the cap.
- Remove the transportation cover from the cartridge mouth.
- Push the cartridge into the breech cap until the two extractor claws clip over the cartridge base.
- Insert the complete assembly into the barrel and screw the breech cap home, handtight only.

- Repeat these operations for the other two barrels.
- Fit the starter cowling nose piece (when applicable).

Note: Cartridges should always be pointed away from the operator and other nearby people.

18. **Unloading.** Before attempting to unload the starter, check that the electrical power supply is OFF, and that the starter itself is sufficiently cool to handle.

- Remove the cowling nose piece (when applicable).
- Depress the plunger in the centre of the cap and unscrew to extract the cartridge.
- Depress the two small plungers to lift the pawls of the cartridge extractor and remove the spent cartridge from the nose cap.

Note. Undamaged spent cartridge cases can be reclaimed; therefore, care must be taken to avoid damaging them.

- Wipe the breech cap with a clean rag, ensuring that the insulating slip ring is free from oil and grease. Examine the breech bore and remove any loose residue. If the grid plate of the cartridge was damaged by the explosion, check that all particles are removed from the breech.

19. **Safety.** The handling of explosive stores requires the utmost care and attention—and starter cartridges are no exception. In your dealings with these potentially dangerous items, always ensure that:

- Cartridges are removed before any servicing task on the engine is begun.
- Spent cartridges are removed from their breeches as soon as possible to avoid the corrosive effect of the explosive residue.
- The starter is allowed to cool before attempting to unload.
- In the event of a misfire, a 'safe' period of at least one minute is allowed, before approaching the starter.
- During start-up procedure, ensure that the safety distances, in front of and behind the engine, are observed.

Liquid Fuel Turbo Starter

20. **Principle.** The turbine and reduction gear mechanisms of a liquid fuel starter are basically similar to those of the triple breech unit. It is designed to fit the same mounting flange on the engine and to engage the compressor shaft in the same manner as that of the cartridge type starter. Here the similarity ends. The turbine of this starter is powered by the gas flow produced when burning a highly volatile liquid fuel (Iso-propyl-nitrate—IPN) in a combustion chamber. IPN is fed into the combustion chamber through a spray type burner and ignited by a high energy electrical spark supplied by the ignition system. The gases produced by burning the fuel are fed on to the blades of the single stage turbine which, through an epicyclic reduction gear, provides the power for turning the engine compressor shaft (Fig 2.7.5). After the aircraft engine reaches a self-sustaining speed, the starting system is closed down by a speed sensitive switch operated when the starter output exceeds 12 000 rev/min.

21. **Iso-propyl-nitrate is a mono-fuel;** that is, it is a fuel which, under certain conditions of temperature and pressure will sustain combustion in the absence of air or other oxidants. In contact with the atmosphere, IPN is very flammable and, when mixed with air, it forms a fuel/air mixture which burns readily and rapidly develops a large volume of gas. When ignited in the confined space of the combustion chamber the temperatures and pressures rise above the critical value needed to support combustion without more air from the atmosphere and, once combustion has started, air is no longer needed.

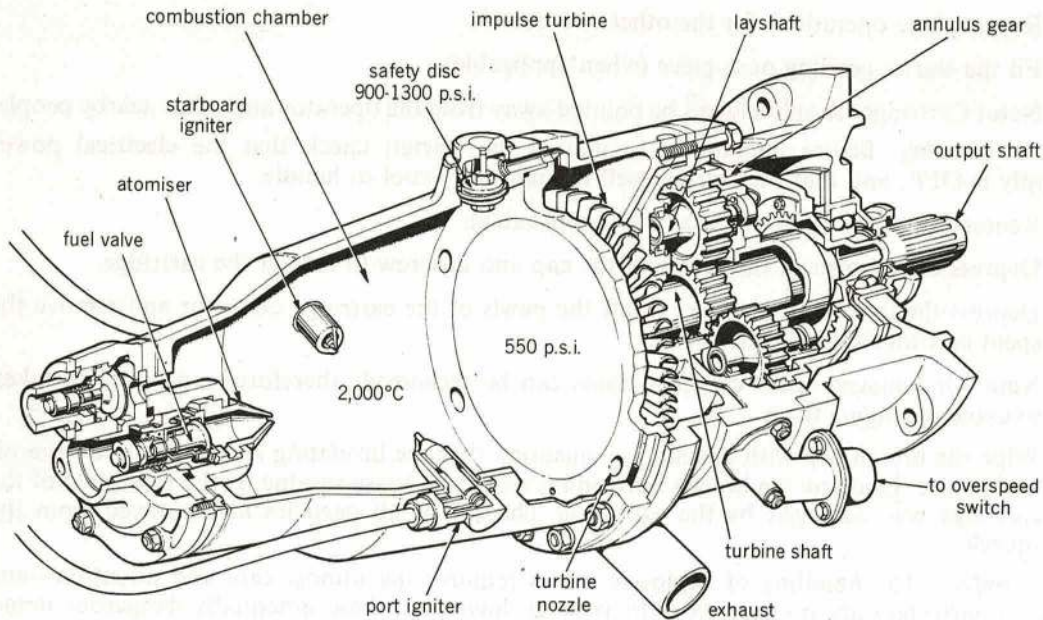

Fig 2.7.5 Liquid fuel turbo starter

22. **Starting the IPN turbo starter.** The liquid fuel turbo-starter motor is, in itself, a gas turbine engine and requires the services of a starting system. The system, which is electrically controlled, includes a fuel tank, suitable fuel and air pumps with connecting pipework, automatic switches and a high energy ignition unit (see Fig 2.7.6). Pressing the engine starter button feeds current to a time switch in the control box; this controls the starting and running sequence of the IPN starter:

- Contacts in the control box close to energize the fuel pump and the air blower in the pumping unit.
- During the first 2 to 3 seconds the air blower provides a flow of air for scavenging the combustion chamber, whilst the fuel flow is diverted back into the fuel tank.
- At 3 seconds, the time switch energizes the fuel supply solenoid valve and fuel is directed to the atomizer head in the combustion chamber of the starter motor.
- Ignition of the fuel in the combustion chamber causes a pressure rise in the fuel line which is sufficient to operate the high pressure switch to:
 - Switch off the starter motor ignition.
 - Operate an 'air dump' valve so that no further air is fed into the combustion chamber. The starter motor is now self-sustaining.
- The exhaust gases from the starter combustion chamber drive the single stage turbine which cranks the aircraft engine for starting.
- After the engine has started, an overspeed switch on the starter motor shuts down the starter system when the starter output shaft reaches 12 000 rev/min.
- If the engine fails to start, the time switch in the control box shuts down after a specified time.

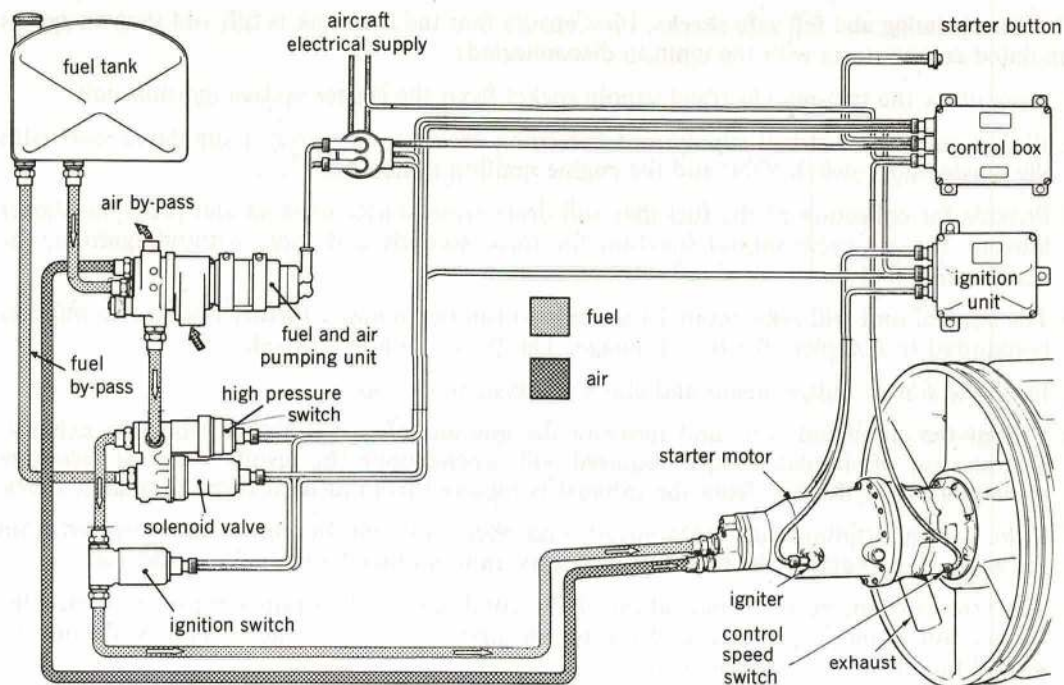

Fig 2.7.6 Liquid fuel starting system

23. **'Light-up' of aircraft engine.** Let us assume the following conditions:

- The aircraft engine compressor is being driven by the IPN starter motor up towards idling rev/min.
- The ignition spark is repeatedly discharging across the face of the igniter plug.
- The correct fuel/air mixture is being sprayed into the aircraft engine combustion chamber.

The high energy spark is obtained from the discharge of capacitors in the high energy ignition units. The instant at which the spark occurs is timed through contacts in the control box (Fig 2.7.6). The timing is such that the engine should 'light-up' and attain idling rev/min between 9 and 10 seconds after pressing the starter button. Whether or not the engine starts, the high energy installation is automatically switched off, by the time switch in the control box about 10 seconds after initiating a start.

24. **Servicing the IPN starter.** For servicing information, refer to the appropriate Air Publications Volume 1 or 6, which lists the correct lubricants, torque loading data, and special tools to be used. If the starter motor is being replaced, the driving pinion must be transferred to the new starter; fuel and air pipe sealing rings and the starter jointing washer must be replaced and, before use, the reduction gear of the starter must be primed with engine oil. During scheduled servicing, the system components and pipelines are examined for security of attachment and fuel leaks. Because there is a possibility of cracks developing, particular attention is given to the starter motor.

After installation of replacement components in a starting system, particularly if electrical or fuel components have been disturbed, fuel priming and 'fail safe' checks must be made to ensure that there are no fuel leaks and that the system actually 'fails safe'. These checks are described in AP103D series and the procedure must be strictly followed. However, for general information the sequence is described below.

25. **Fuel priming and fail safe checks.** First ensure that the fuel tank is full and then carry out simulated engine starts with the ignition disconnected:

- Disconnect the two-pin electrical supply socket from the starter system ignition unit.
- With a suitable electrical supply, not exceeding 26 volts, carry out a simulated start with the master start switch 'ON' and the engine ignition switch 'OFF'.
- Provide for collection of the fuel that will drain from starter exhaust and press the starter button. The air cycle should function for three seconds and then, without ignition, the system will 'shut down' as a 'fail safe' precaution.
- The control unit will take about 18 seconds to run down and a further one to two minutes is required to complete the fuel drainage. The system is now primed.
- Press the starter button again and check the system for leaks.
- Repeat the simulated start and measure the amount of fuel drainage from the exhaust. The number of simulated starts required will depend upon the results obtained; accurate measurement of the fuel from the exhaust is required from at least three simulated starts.
- If the system is 'failing safe' mechanically and electrically, the amount of fuel obtained from the exhaust, on each of the measurement tests, should range between 75 cc and 100 cc.
- The rate of drainage is an indication of the condition of the drain system. A serviceable system will drain 75% of the fuel during the first minute, and the remainder during the second minute after a simulated start.
- If 'fail safe' tests are satisfactory, remove all traces of the fuel from around the starter exhaust and reconnect the ignition unit.

WARNING: It is important that no attempt be made to carry out a 'fail safe' check when the starter is hot. At least one hour must elapse after a start, before a check is made.

26. **Handling IPN—safety precautions.** Because there is danger in careless handling of IPN liquid fuel, stringent safety rules are laid down concerning container material and personnel protection. These rules are produced in the appropriate aircraft AP. The fuel is highly corrosive and it is important to avoid spilling, particularly when filling the starter system tank in the aircraft. IPN (AVPIN) liquid fuel is normally stored in 20 litre or 200 litre drums; because of its dangerous nature, bulk storage underground is not permitted and no storage containers must exceed 200 litres.

AVPIN is a Class A dangerous fluid with a flash point of 52°F (+ 11°C) (AP 830 Vol 2 leaflet A8 refers), and adequate fire precautions are necessary. Safety tools are required for opening the drums to avoid the possibility of sparks causing an explosion. Fuel dispensers and funnels should be made from spark proof materials such as polythene; metal containers should never be used. Funnels and dispensers should be marked 'AVPIN ONLY', and the only approved cleaning agent is methylated spirit.

The containers should be stacked in single tiers, on mounting stands in a cool, well-ventilated place. The fuel is drawn off through a tap as required for replenishing starter systems.

AVPIN gives off poisonous fumes; it can also be absorbed through the skin; therefore, protective clothing is to be worn when working with AVPIN. Always wash the hands and face after working with AVPIN, regardless of whether or not there are obvious signs of contamination.

Air Driven Turbo Starters

27. Air-driven turbo starters are lighter than the turbo-starters described in the preceding paragraphs; they consist of a turbine, reduction gear, clutch and driving shaft (Fig 2.7.7). Low

pressure air at about three bars (40 psi approx) is used to drive the turbine which produces the torque needed to spin the engine shaft for starting. The low pressure air supply may be obtained from any of the following sources:

- An external ground supply (*eg* low pressure air trolley).
- An airborne Auxiliary Power Plant (AAPP) in the aircraft.
- Air from the compressor of an engine that is running (multi-engined aircraft).
- A combustor (*see* para 29).

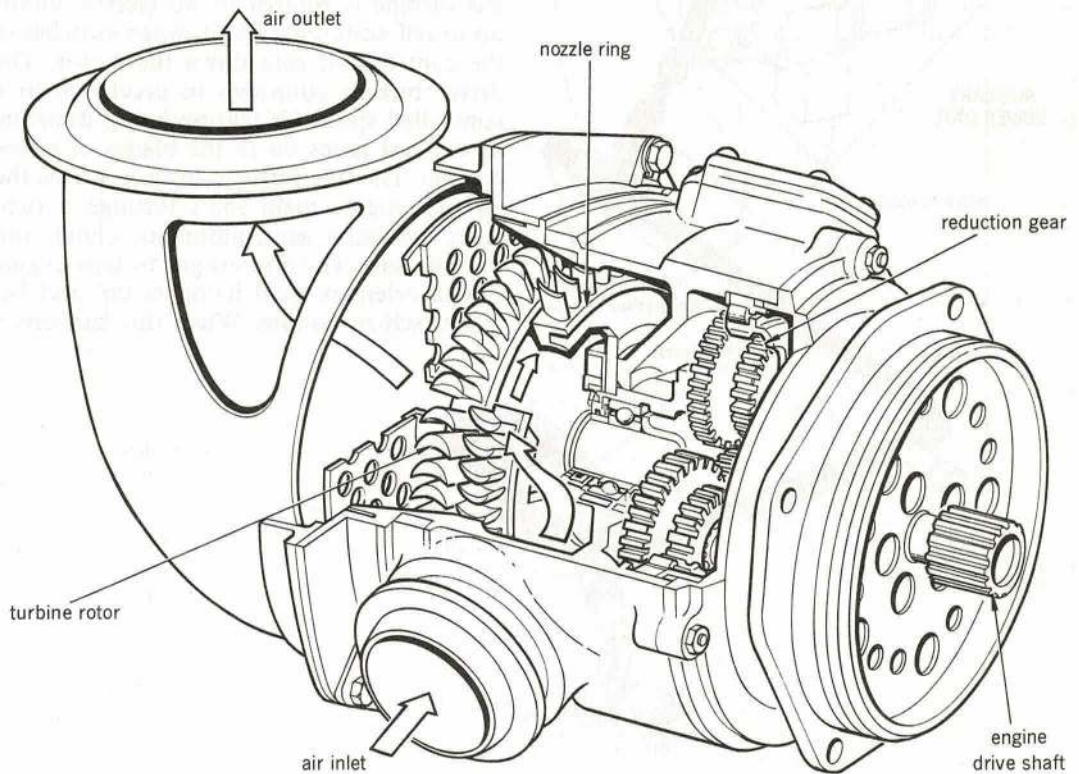
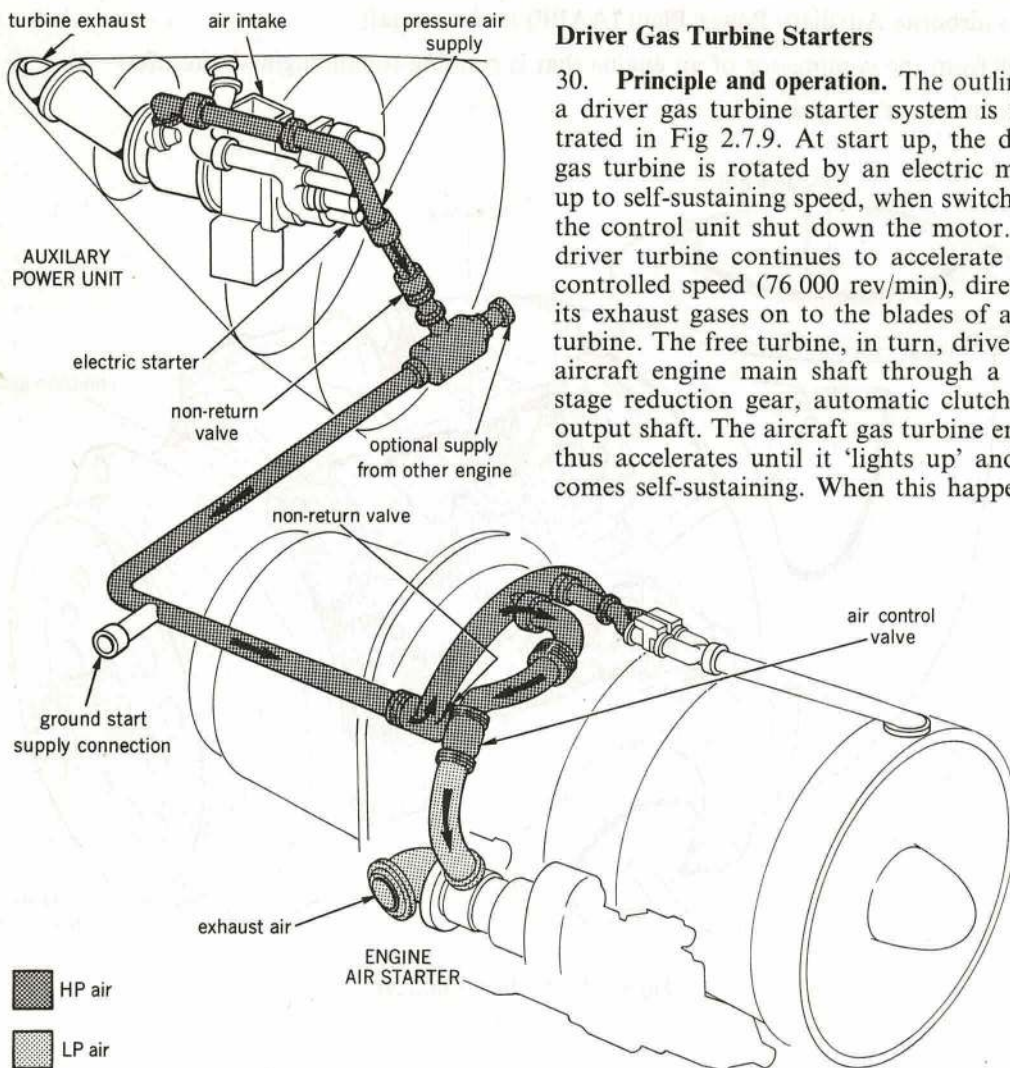

Fig 2.7.7 Air turbo-starter

28. **Operation.** The air supply from any of the sources listed above is directed to the starter through an electrically operated control and pressure reducing valve (Fig 2.7.8). This valve opens when an engine start is selected and shuts off the air supply at a pre-determined starter speed. After 'light up' as the engine accelerates to idling speed, the clutch disengages and the starter comes to rest ready for the next start.

29. **Combustor.** This is used in conjunction with an air-driven turbo starter where no external air supply is available. It is sometimes fitted to one engine of a multi-engined aircraft. The combustor consists of a small combustion chamber in which engine fuel mixes with high pressure air (about 215 bars, 3000 psi) and is burned to provide a gas flow to power the air starter turbine. The high pressure air is obtained from storage bottles in the aircraft and the supply to the combustor is controlled by electrically-operated valves. The airflow pressurizes

a fuel accumulator to produce an atomized fuel flow and simultaneously activates the continuous ignition system. The fuel/air mixture burns in the combustion chamber and the exhaust gas is directed onto the turbine blades of the air turbo starter. Time switches shut off the system on completion of the starting cycle.



Driver Gas Turbine Starters

30. Principle and operation. The outline of a driver gas turbine starter system is illustrated in Fig 2.7.9. At start up, the driver gas turbine is rotated by an electric motor up to self-sustaining speed, when switches in the control unit shut down the motor. The driver turbine continues to accelerate to a controlled speed (76 000 rev/min), directing its exhaust gases on to the blades of a free turbine. The free turbine, in turn, drives the aircraft engine main shaft through a two-stage reduction gear, automatic clutch and output shaft. The aircraft gas turbine engine thus accelerates until it 'lights up' and becomes self-sustaining. When this happens a

Fig 2.7.8 The air starter system

frequency signal (fed back to the control unit from the aircraft ac generator) causes the driver gas turbine to shut down and the free turbine to be disengaged from the output shaft.

31. Construction. A typical driver gas turbine starter (which includes also the free turbine) is illustrated in Fig 2.7.10. It consists of a small compact gas turbine engine, featuring a turbine-driven centrifugal air compressor, a reverse flow combustion system, and a mechanically independent free-power turbine. The free turbine drives the engine main shaft through a two-speed epicyclic reduction gear, automatic clutch and output shaft. This type of starter unit is economical to operate and provides a high power output for a low weight.

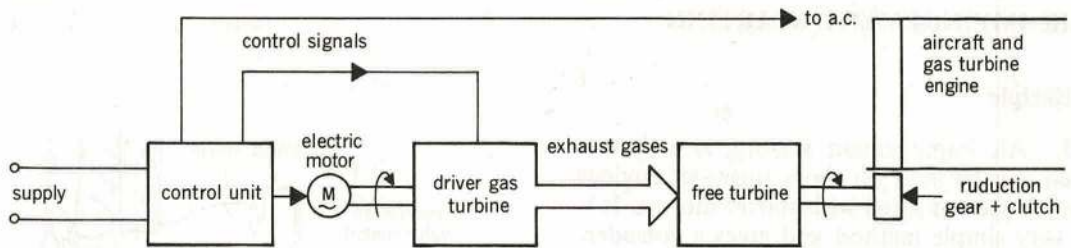

Fig 2.7.9 Driver gas-turbine starter system

32. **Use as an auxiliary power unit.** The driver gas turbine starter system can also be used in the role of an auxiliary power unit (APU) as well as that of a gas turbine starter (GTS). A combined GTS/APU of this type is fitted to the Pegasus engine of the Harrier aircraft. It is similar in basic construction to the unit illustrated in Fig 2.7.10. The driver gas turbine operates on fuel from the aircraft's tanks and, as well as cranking the main engine, it drives an accessories gearbox and an auxiliary generator. The free power turbine is used exclusively for cranking the Pegasus engine, through a reduction gear and clutch unit. The GTS/APU can be selected and operated as a means of starting the aircraft engine or as a ground auxiliary power unit to supply power for aircraft services. When used as an APU, a brake grips the free turbine mechanism to prevent rotation of the Pegasus engine.

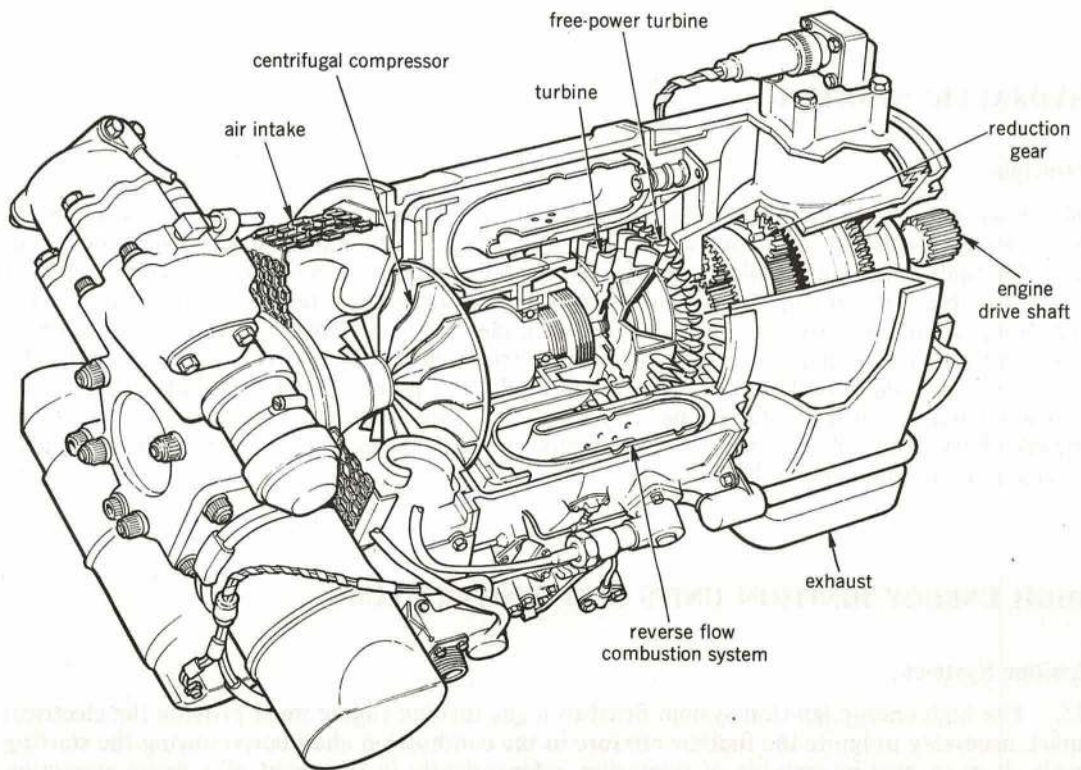

Fig 2.7.10 A driver gas-turbine starter

AIR IMPINGEMENT STARTING

Principle

33. Air impingement starting is a system that can be used on those turbo-jet engines which are not fitted with starter motors. It is a very simple method and gives a considerable saving in weight compared with other starting systems. An external air supply is connected to the engine, as illustrated in Fig 2.7.11, and jets of air impinge directly on to the engine turbine blades to rotate the engine up to self-sustaining speed. The air feed to the turbine is controlled by a simple on/off cock and the engine ignition system is controlled by a suitable timing device. The considerable amount of high velocity air required for this type of starting is obtained from an external source or, on multi-engined aircraft, from an engine that is running; it is fed through non-return valves and nozzles on to the turbine blades.

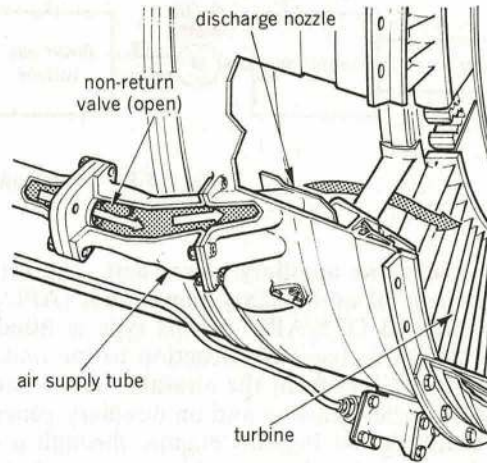

Fig 2.7.11 Air impingement starting

HYDRAULIC STARTING

Principle

34. Exceptionally, some of the small gas turbine engines may be started by feeding hydraulic oil at high pressure to an engine-driven hydraulic pump. The engine-driven hydraulic pump used for engine starting is called a pump/starter and is capable of spinning the engine up to a speed suitable for 'light up' and then assisting it to reach self-sustaining rev/min. Power for the pump/starter is provided by hydraulic oil under pressure from a 'ground supply unit'. The starting operation is controlled by an electrical circuit which also operates hydraulic valves, so that, on completion of the starting cycle, the pump/starter functions as a normal hydraulic pump. Other installations may use a separate hydraulic pump for starting. The means of transmitting the torque to the engine may also vary but, in every case, a suitable disengaging mechanism will be included.

HIGH ENERGY IGNITION UNITS AND IGNITER PLUGS

Ignition Systems

35. The high energy ignition system fitted to a gas turbine engine must provide the electrical spark necessary to ignite the fuel/air mixture in the combustion chamber(s) during the starting cycle. It must also be capable of operating independently in the event of a flame extinction (flame out) in flight. A dual system is used on each engine to provide a positive light up on starting, with each high energy ignition unit connected to its own igniter plug. To aid flame

propagation, each of the two igniter plugs is situated in a different combustion chamber or at different positions in an annular chamber.

36. Electrical energy (measured in joules) is the product of voltage, current and time. Thus, if we require to produce a high energy spark (which lasts for only a fraction of a second) we shall usually need both high voltage and high current.

The actual energy required to ensure ignition varies with atmospheric and flight conditions; for example, more energy is required as the altitude increases. Thus, high energy (12 joules) systems are normal for certain conditions of flight and for engine starting. For other adverse conditions, such as icing or when taking-off in heavy rain or snow, it may be desirable to have the ignition system operating continuously to give an automatic re-light should 'flame-out' occur. For continuous operation, a low energy (3 joules) system is adequate. Where continuous operation of the ignition unit is not desirable, a 'glow plug' can be fitted in the combustion chamber to ensure re-light if needed.

37. **Re-lighting in flight.** Certain unusual conditions of flight may extinguish the flame in the combustion chamber(s) leaving the aircraft without power. Provision is made to re-start the engine in flight, but the pilot may need to fly at a favourable altitude and forward speed to achieve this. If the pilot is able to fulfil these conditions, and the engine has no mechanical defects the engine compressor will 'windmill' to provide a fuel flow and the conditions will be suitable for re-starting the engine. Because the engine is turning, the starter motor is not needed during a re-light start of the engine. Consequently, the re-light switch is designed to energize the ignition system only.

High Energy Ignition Unit

38. **Basic operation.** The outline of a high energy ignition system is illustrated in Fig 2.7.12. Each high energy ignition unit has a low voltage supply which is controlled by the control unit in the starting system. Depending upon the engine and installation, the supply voltage may be either direct current (dc) or alternating current (ac). If the supply is dc, either a trembler mechanism or a transistor generator is used to convert the dc input to low voltage ac. Thereafter, the operation is the same as that of the system supplied with ac:

- The low value of ac is stepped up to a high value by a transformer.
- The high value alternating voltage is then 'rectified' to provide a high value of direct voltage which is used to charge a capacitor.
- When the capacitor voltage is high enough it breaks down a discharge gap and the discharge is applied to the igniter plug when the energy (high voltage, high current) is converted to a spark across the face of the igniter plug.

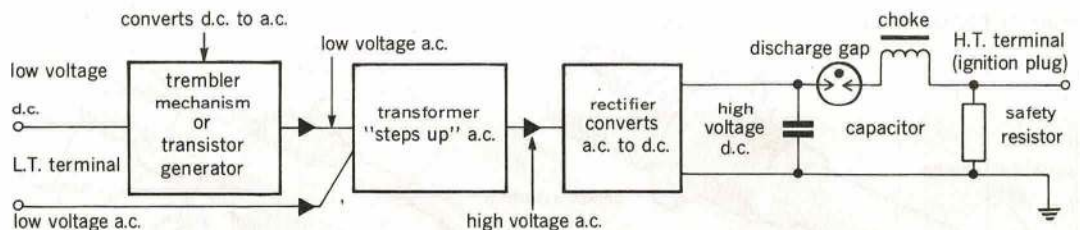

Fig 2.7.12 High energy ignition unit—basic outline

39. **Construction.** A modern transistorized version of a high energy ignition unit is illustrated in Fig 2.7.13. Although the construction varies according to the type of ignition unit, the basic

operation is as described in para 38. A choke is fitted to extend the duration of the discharge and safety resistors are fitted to ensure dissipation of energy in the capacitors.

LETHAL WARNING. The electrical energy stored in the HE ignition unit is potentially lethal and, even though the capacitor is discharged when the electrical supply is disconnected, safety precautions are necessary. Before handling the components the associated circuit breaker should be tripped, or the fuze removed. Never rush in; at least one minute must be allowed between disconnecting the power supply and touching the ignition unit, HT lead, or igniter plug.

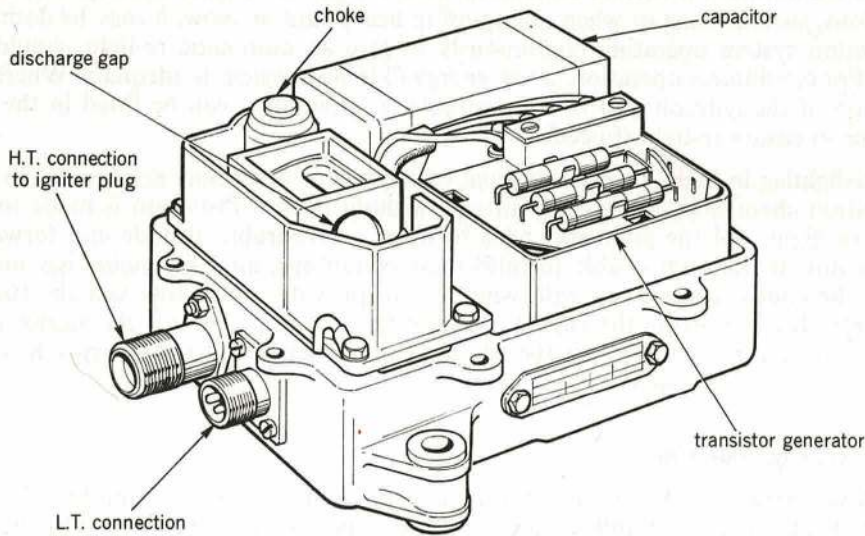

Fig 2.7.13 Transistorized ignition unit

Igniter Plug

40. The igniter plug consists of a central electrode and an outer body, the space between being filled with an insulating material which terminates at the firing end of the electrode (Fig 2.7.14). During operation a small electrical leakage from the ignition unit is fed through the central electrode to the plug body to produce an ionized path across the surface of the pellets; any subsequent high intensity discharge takes place across this low resistance path. This igniter plug is classed as a 'surface discharge' plug because the energy does not have to jump an air gap. The contact button mates with a similar button on the ignition lead.

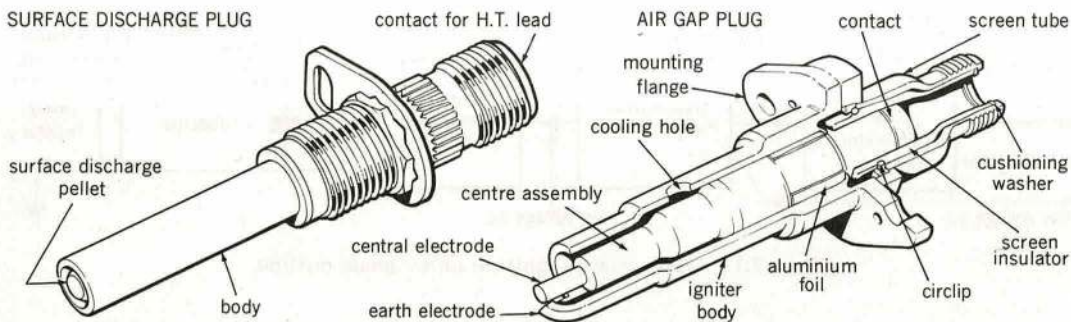

Fig 2.7.14 Typical igniter plugs

Ignition Lead

41. The high energy ignition lead that is used to carry the intermittent high voltage outputs from the ignition unit to the igniter plug, consists of a single insulated core encased in a flexible metal sheath and it terminates in a spring-loaded contact button at each end. The end fittings usually incorporate a self-locking attachment nut.

Servicing the Ignition System

42. Before any servicing is carried out on an ignition system you must read the relevant Safety and Servicing Notes together with technical orders relating to this work. You must, in particular, understand the lethal warning notice regarding handling high energy ignition equipment and the safety precautions you are to observe.

43. **Repairs and testing.** Repair and testing of HE ignition system components is the responsibility of the electrical tradesman. However, if an igniter plug becomes unserviceable, it is removed and the replacement is fitted by the aircraft fitter (propulsion) who will also examine the HE ignition unit mountings and the condition of the HT leads.

44. The ignition leads should be examined for security and the sheath should be examined in the vicinity of the support clips for signs of chafing or other damage, such as oil contamination or fracture. Before a new ignition lead is fitted, the spring-loaded contacts should be examined for freedom of movement, and the electrical tradesman should test continuity and insulation.

54. Igniter plugs are removed for examination as part of the scheduled servicing but, if they are removed at any other time, take the opportunity to examine the plugs for signs of heat damage, cracks, and erosion of the pellet surface. Igniter plugs are not normally cleaned on the discharge surfaces because a carboned igniter plug tends to give a better spark (flash over). However, if the carbon deposits prevent examination of the pellet they may be cleaned off, provided that the pellet is not damaged in the process; areas other than the discharge surfaces may be cleaned with a cloth damped with white spirit.

46. When a new igniter plug is to be fitted a new sealing washer must be used; the threads of the plug should be smeared lightly with anti-seize compound and the plug should be tightened to the correct torque-loading value.

Testing the System

47. Functional tests of the ignition system are a part of a scheduled servicing, but the system must be proved whenever any ignition system component has been changed. The testing is done by the electrical tradesman who is aided by the aircraft fitter (propulsion). The aircraft should, when possible, be located in the open air and the engine compartment must be free from fuel leaks and flammable vapours. Adequate fire extinguishers must be available and then the system can be functionally tested by operating the re-light switch. Test each ignition system in turn by isolating the other, either by fuze removal or circuit breaker whichever is simpler. If the ignition system is working correctly, the 'flash over' will be heard as a regular cracking noise from the igniter plug.

48. After changing a component, such as a time delay unit which affects the whole system, a full functional test is necessary. The ignition system can be tested as described in para 47 but the operation of the delay unit can only be tested during a 'dry run'. For a 'dry run' the preparations are the same as those necessary for a normal engine start but, when the starter switch is operated, the HP fuel cock remains 'OFF'.

This file was downloaded from the RTFM Library.
Link: www.scottbouch.com/rtfm

Please see site for usage terms, and more aircraft documents.

