

Chapter 3 EMERGENCY CONTROLS, EQUIPMENT AND EXITS

LIST OF CONTENTS

	Para.		Para.		Para.
Introduction	1				
Controls		Jettison system controls		Equipment	
Air systems	2	Bombs, flash bombs and flares ...	9	Type M.S.9 dinghies	15
Alighting gear	3	Auxiliary fuel tank	10	Type S.S. dinghies	16
Flaps	4	Automatic fire extinguisher		Parachute packs	17
Bomb doors	5	system controls		Miscellaneous equipment	18
Retractable scanner	6	Engines	11	Ditching and crash stations ...	19
Manual operation of hydraulic		Fuel and water/methanol		Exits and rescue points	
control valves		fluid tanks	12	Parachute exit	20
Flaps	7	Warning horns	13	Escape and ditching exits	21
Scanner	8	Miscellaneous	14	Fuselage door	22
				Rescue and break-in points ...	23

LIST OF ILLUSTRATIONS

	Fig.		Fig.
Emergency equipment and controls	1	Emergency exits, ditching and crash stations	4
Forward dinghy release	2	Rescue and break-in points ...	5
Aft dinghy release	3		

ADDENDUM 1 - PHASE 2

	Fig.
Emergency equipment and controls ...	1A

Introduction

1. This chapter describes the controls, equipment and exits provided for use in emergency and contains, where necessary, brief descriptions of their use and operation. The location of each control, item of equipment or exit is shown in the illustration indicated after the title of the paragraph in which it is described.

CONTROLS

Air systems

2. Three separate air systems are fitted for the emergency operation of the hydraulic services as follows:-

- (1) Alighting gear and flaps
- (2) Bomb doors
- (3) Retractable scanner

Alighting gear (fig.1)

3. Emergency lowering of all three wheels can be accomplished by operating the left hand lever of a pair at the bottom of the flight engineer's panel slightly to

port of centre. The lever is held in the 'OFF' position by a quick-release pin which must be removed before operation of the lever is possible. Although the wheels are lowered by this system irrespective of the positions of the normal hydraulic control push-buttons, nevertheless the "DOWN" button should be pressed in prior to operating the lever, which should then be held down until the wheels are locked down. Selection of undercarriage DOWN operates the associated hydraulic control valve to prevent any loss of air pressure, which may cause the wheel unit down-locks to be released with consequent collapse of the units, and will cause the automatic retraction of the scanner, provided that the associated hydraulic circuit is serviceable. After the alighting gear has been lowered, a check must be made of the scanner position.

Flaps (fig.1)

4. Operation of the emergency air

control lever, which is to starboard of the alighting gear lever, admits compressed air to the flaps hydraulic control valve, and the flaps may be lowered or raised in the usual manner by use of the flap selector switch on the pilots' panel.

Bomb doors (fig.1)

5. Two control levers, one for opening and one for closing the bomb doors, are fitted on the port side of the bottom of the flight engineer's panel. The levers are held in the 'OFF' position by a spring-loaded slide pin arranged to release one lever only at a time. The left-hand lever is labelled OPEN and the right one CLOSED.

Retractable scanner (fig.1)

6. On the port side of the radar operator's scanner control panel is an emergency air control lever, which, when depressed, admits air to the up line of the scanner control

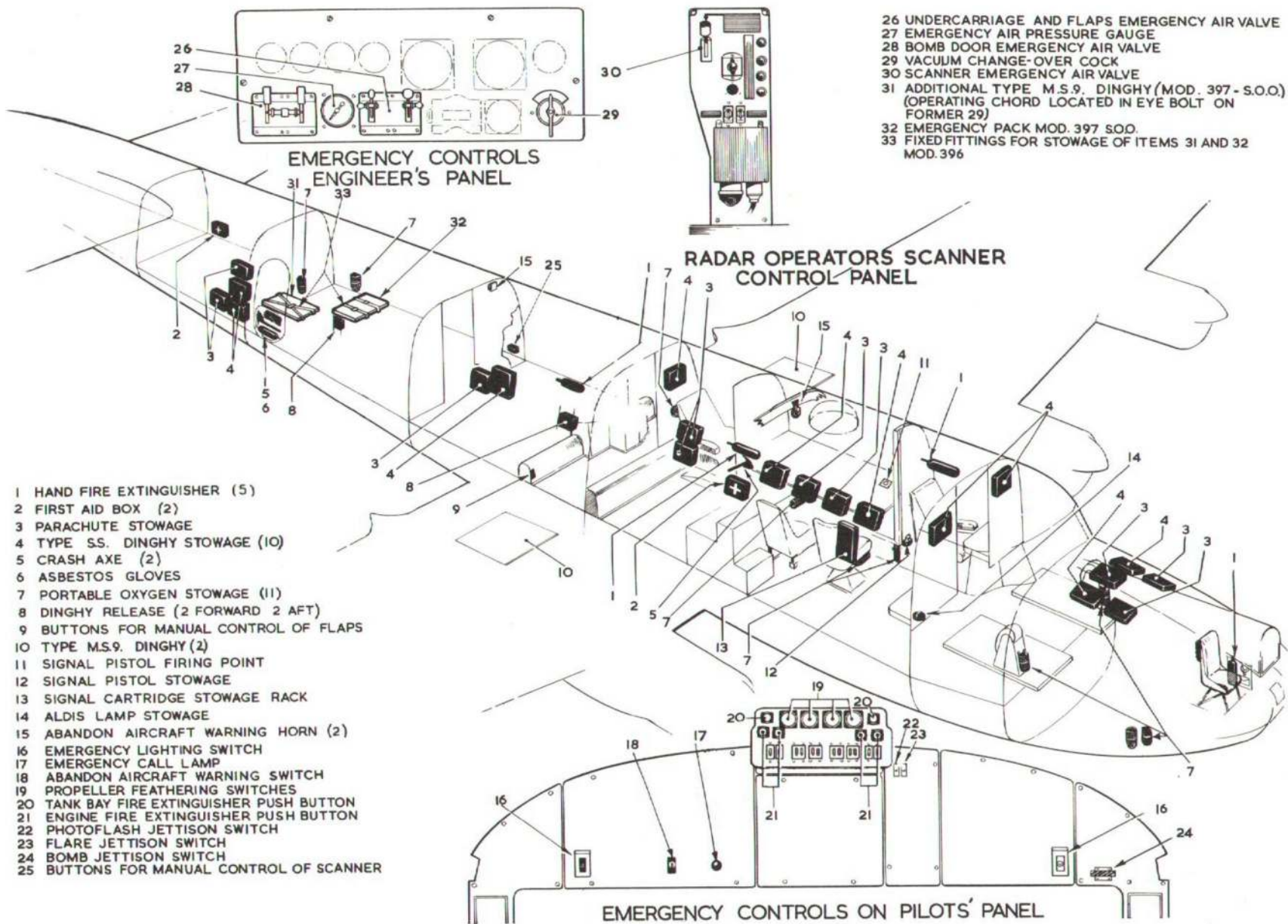

Fig. 1. Emergency equipment and controls

RESTRICTED

circuit and retracts the scanner from any of its three down positions. The scanner cannot be lowered by use of this system.

WARNING...

The scanner is arranged to retract automatically if the undercarriage DOWN push-button is pressed. If the undercarriage fails to lower and the scanner does not retract, set the scanner control switch to UP prior to operating the undercarriage emergency lowering air control. This prevents loss of oil should the scanner be selected UP after undercarriage emergency lowering. When the scanner retracts simultaneously with undercarriage lowering the time of these two operations occurring together is equal to the sum of the times for each service when operated separately, i.e., 40-45 seconds.

MANUAL OPERATION OF HYDRAULIC CONTROL VALVES

Flaps (fig.1)

7. In the event of failure of the flaps control valve electrical circuit, the valve may be manually operated by the use of

two small spring-loaded push-buttons situated one above the other on the forward face of the valve. The push-buttons are reached through a hole in the starboard flap jack cover and their use is as described on an adjacent label on the cover which reads MANUAL OPERATION OF FLAP CONTROL VALVE, TOP BUTTON-FLAPS UP, LOWER BUTTON-FLAPS DOWN. When the push buttons are used, the appropriate button must be pressed until the flaps have reached the desired attitude.

Scanner (fig.1)

8. Two similar buttons are provided on the scanner control valve, which is basically the same type as that used in the flaps circuit. This valve is mounted on a bracket attached to the port side of the fuselage floor between formers 22 and 23, and is covered by a guard. An opening in the aft face of the guard enables the two buttons to be manually operated. Inscribed on the guard is UP, above the opening, and DOWN, below the opening, indicating that the upper button is to be pressed for retraction of the scanner, and the lower button pressed for lowering

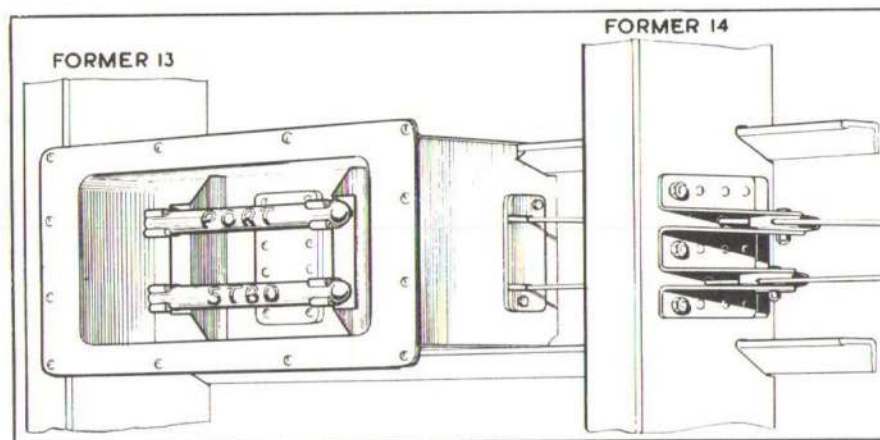

Fig.2. Forward dinghy release

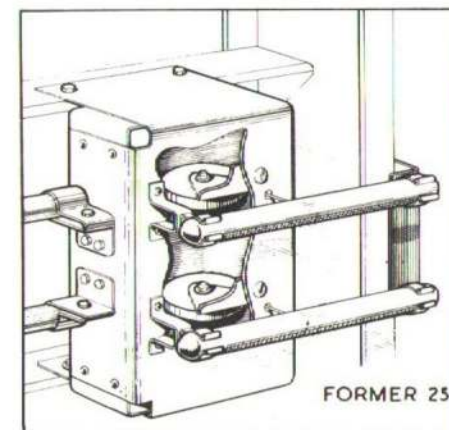

Fig.3. Aft dinghy release

it. The buttons are spring-loaded to OFF and each must be kept pressed until the desired movement of the scanner is complete.

**JETTISON SYSTEM CONTROLS
Bombs, flash bombs and flares (fig.1)**

9. Flare and flash bomb jettisoning switches are mounted on the pilot's panel to starboard, near the top right corner of the central engine instrument panel. A bomb jettisoning handle is fitted on the extreme right-hand panel. After the bomb doors have been opened, all stores may be jettisoned from the bomb-racks by pulling the handle.

Auxiliary fuel tank

10. This may be jettisoned by operating the bomb jettison handle.

**AUTOMATIC FIRE EXTINGUISHER
SYSTEM CONTROLS**

Engines (fig.1)

11. In the event of fire occurring in any of the engines during flight, the extinguisher system can be brought into operation manually by depressing the appropriate push-button on the pilot's panel, or automatically by feathering the propeller of the engine concerned. Should the aircraft crash with sufficient impact to operate the inertia switches in the nose

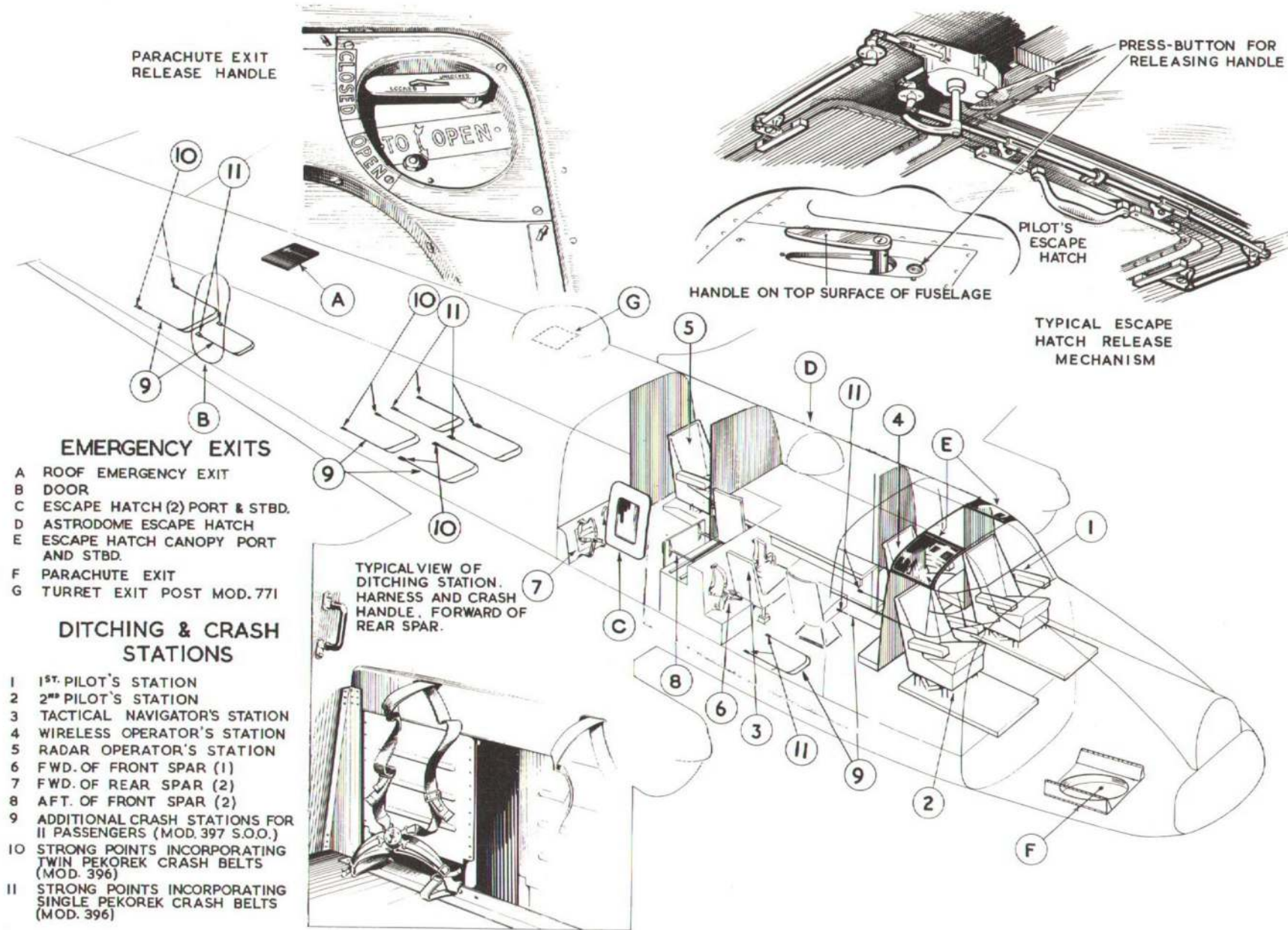

Fig. 4. Emergency exits , ditching and crash stations

RESTRICTED

of the aircraft, the whole system will be operated. The system is described in Sect 4, Chap.5 and Sect.5, Chap.1.

Fuel and water/methanol fluid tanks (fig.1)

12. Automatic operation of this system is initiated by the inertia switches in the nose. ► ◀ If the automatic operation should fail, manual operation of either the port or starboard half of the system may be effected by depressing the appropriate push-button on the upper centre portion of the pilots' panel. The system is described in Sect.4, Chap.5 and in Sect.5, Chap.1.

WARNING HORNS (fig.1)

13. Warning to abandon the aircraft is given by pressing a push-button on the pilots' panel. This operates an electric horn at former 6 and another at former 22 above the rest bunks.

MISCELLANEOUS (fig.1)

14. These are as follows:-

- (1) A vacuum change-over which, if operated in the event of failure of the vacuum pump normally connected to the flight instruments, connects them to the pump normally connected to the Mk.3 bomb sight. The control is situated at the bottom of the flight engineer's main panel.
- (2) Two release points for the Type M.S.9 dinghies in the wings (para. 15) are fitted on the port side of the fuselage. One is between formers 13 and 14 (fig.2) and the other is between formers 24 and 25 (fig.3).
- (3) Two emergency lighting switches are located in the cockpit, one at the lower left hand corner of the first pilot's flying instrument panel and the other at the lower right hand corner of the second pilot's flying instrument panel.
- (4) An I.F.F. distress signal switch at the bottom of the first pilot's flying instrument panel.

NOTE... This switch is deleted on the Phase II aircraft.

- (5) Four propeller feathering switches on the upper centre portion of the pilots' panel.

EQUIPMENT

Type M.S.9 dinghies (fig.1)

15. Each dinghy release point incorporates two dinghy release toggle handles (fig.2 and 3). The upper toggle at each point releases the port dinghy and the lower toggle releases the starboard dinghy. Direct manual removal of the lids of the two dinghy compartments in the centre-plane trailing edge can be effected by breaking a transparent panel over a release handle, visible through the panel in each compartment lid. When a lid has been removed the inflation gear can be operated by a sharp pull on the cord near the inflation bottle. The system is described in Sect.3, Chap.11, Mod.397 (S.O.O.) introduces an additional Type M.S.9 dinghy for use by passengers. The dinghy valise is strapped to fittings (Mod.396) secured to the floor aft of the aircraft entrance door, the operating cord being attached to an eyebolt at former 29, about 12 in. above floor level. An emergency pack is also similarly secured to the floor opposite the door.

Type S.S. dinghies (fig.1)

16. Ten of these dinghy packs are carried in stowages located as shown in the illustration.

Parachute packs (fig.1)

17. Ten parachute packs are carried for the crew in stowages adjacent to crew stations.

Miscellaneous equipment (fig.1)

18.(1) Stowage for an axe, fire extinguisher and asbestos gloves is provided in a detachable compartment in the main door. The detachable compartment is removable from the outside of the door by lifting two catches low down on the panel and pulling outwards and downwards to free the two locating dowels at the top. An additional axe is stowed on the starboard side of the fuselage opposite the navigator's station.

- (2) Hand fire extinguishers and portable oxygen bottles are stowed near each crew station.
- (3) Two first-aid kits are provided, one on the port side of the fuselage which is easily accessible from the outside of the fuselage, and one on the starboard side of the centre section.
- (4) A desert equipment trunk (S.O.O.) with a 15-gallon water tank strapped to the lid, can be fitted to the fuselage floor on the port side between former 25 and 27. A detailed list of equipment stowed in the trunk is given in Vol.3, Part 2 (Appendix 'A') of this publication.

DITCHING AND CRASH STATIONS (fig.4)

19. Four members of the crew, namely, both pilots and the wireless and radar operators, remain strapped in their seats. The navigator seated immediately forward of the front spar turns to face forward in his seat and uses the straps provided on the front spar. The remaining five crew members take station as follows:-

- (1) One at the step at the forward face of the front spar, alongside the navigator.
- (2) Two sitting on the floor aft of the front spar facing aft with their backs against the padded surfaces provided, which are normally stowed folded and must be opened up before use.
- (3) Two sitting on the floor forward of the rear spar and facing forward.

Quick-release harness is provided at the three forward facing stations. Aircraft incorporating Mod.397 (S.O.O.) and Mod.396, which provides the necessary attachment points on the floor, are equipped with eleven additional ditching and crash stations which all face aft. One of these is used by the flight engineer, instead of his original station, and is located between his own and the wireless operator's seats. The eleven passenger crash stations are, therefore, as follows:-

- (1) One behind the flight engineer's seat.

- 1 FIRE EXTINGUISHER, AXE AND ASBESTOS GLOVES STOWAGE, IN EXTERNALLY REMOVABLE DOOR PANEL.
- 2 ESCAPE HATCH
- 3 MID-UPPER TURRET-BREAKABLE PANEL IN FAIRING
- 4 BREAK-IN PANEL DEFINED BY SEGMENTED RED LINE
- 5 STEP
- 6 DITCHING EXITS TO WINGS - PORT AND STARBOARD
- 7 FIRE EXTINGUISHER AND AXE - ACCESSIBLE INSIDE
- 8 FIRST AID KIT - ACCESSIBLE INSIDE
- 9 BREAKABLE ASTRODOME
- 10 FIRE EXTINGUISHER - ACCESSIBLE INSIDE
- 11 TWO ESCAPE HATCHES IN CANOPY
- 12 BREAKABLE WINDOWS - PORT AND STARBOARD
- 13 SLIDING WINDOWS - PORT AND STARBOARD - BREAK FORWARD LOWER CORNERS TO REACH CATCHES
- 14 BREAKABLE WINDOW. BOMBSIGHT CAN BE SLID CLEAR
- 15 FIRST AID KIT - ACCESSIBLE EXTERNALLY BY PULLING HANDLE
- 16 BREAKABLE REAR FAIRING
- 17 FIRE EXTINGUISHER - ACCESSIBLE INSIDE (POST MOD.771)

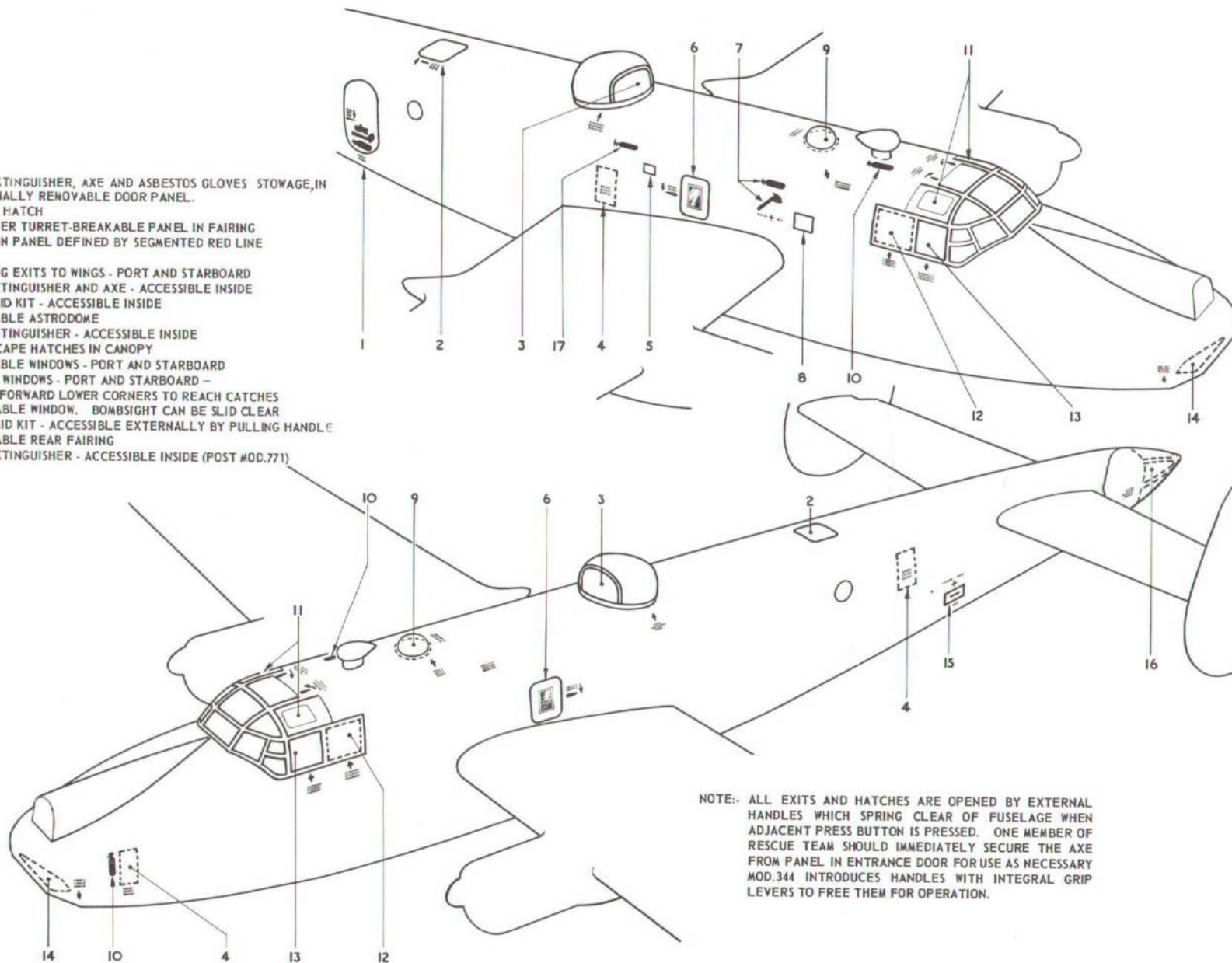

NOTE:- ALL EXITS AND HATCHES ARE OPENED BY EXTERNAL HANDLES WHICH SPRING CLEAR OF FUSELAGE WHEN ADJACENT PRESS BUTTON IS PRESSED. ONE MEMBER OF RESCUE TEAM SHOULD IMMEDIATELY SECURE THE AXE FROM PANEL IN ENTRANCE DOOR FOR USE AS NECESSARY MOD.344 INTRODUCES HANDLES WITH INTEGRAL GRIP LEVERS TO FREE THEM FOR OPERATION.

Fig.5. Rescue and break-in points

RESTRICTED

- (2) One aft of the rear spar.
- (3) Two double and two single stations, one of each secured to the floor at former 19 and between formers 21 and 22.
- (4) One single station at former 30 and a double station at former 32.

EXITS AND RESCUE POINTS

Parachute exit (fig.4)

20. The parachute exit is in the floor of the nose of the aircraft and can be used by all crew members. The exit is covered by two doors to which are fitted the air bomber's leg cushions. The doors can be opened to expose the exit door below and are held shut by fore-and-aft bolts which are released by pressing together two finger latches on the outer half of each door. The release handle for the escape hatch is at the forward starboard corner of the circular pressing in which the hatch is held by two bolts and a pin set round

the circumference of the circular opening. Inscriptions CLOSED and OPEN are provided on the rim of the pressing adjacent to the handle and are located to indicate the use of the handle. This, in turn, is inscribed LOCKED and UNLOCKED with reference to a pointer which protrudes through the face of the handle and is integral with a handle release grip under the handle. The bottom of the dishing for the handle assembly is inscribed OPEN, with a bent arrow indicating the direction of operation of the handle. The door is automatically jettisoned when released.

Escape and ditching exits (fig.4)

21. In addition to the parachute exit, there are five (six when the turret and its cupola are replaced by the emergency exit panel) emergency escape exits which are shown in the illustration. Each handle is protected against inadvertent operation by a locking device which must be released by use of an adjacent press-button before the handle can be turned to open the exit. Mod.344 introduces handles with integral grip levers to free them for operation.

Fuselage door

22. This is provided with a handle and lock of the same type as those of the escape hatches. This door may be used as a parachute exit if the crew members are at the rear crew stations, or if a large crew is carried. It is jettisoned by pulling a handle located between the door hinges and indicated by an arrow. The inscription TO JETTISON DOOR-PULL is painted in red paint on the inside of the door, which after release, must be lifted clear of its frame and manually jettisoned top or bottom end first.

RESCUE AND BREAK-IN POINTS (fig.5)

23. The aircraft is marked externally to indicate to rescuers the position of the door, hatches, break-in points and fire extinguishers. Inscriptions giving instructions for break-in or opening panels are painted in red letters adjacent to each relevant part of the aircraft. The key on the illustration gives a general guide to those instructions.



ADDENDUM 1

MOD.771 - INTRODUCTION OF PHASE 2
EQUIPMENT

EMERGENCY EQUIPMENT AND CONTROLS

The illustration which follows depicts the changes in emergency equipment and controls when Phase 2 is embodied in the aircraft.

LIST OF ILLUSTRATIONS

	Fig.
Emergency equipment and controls - Phase 2	1A

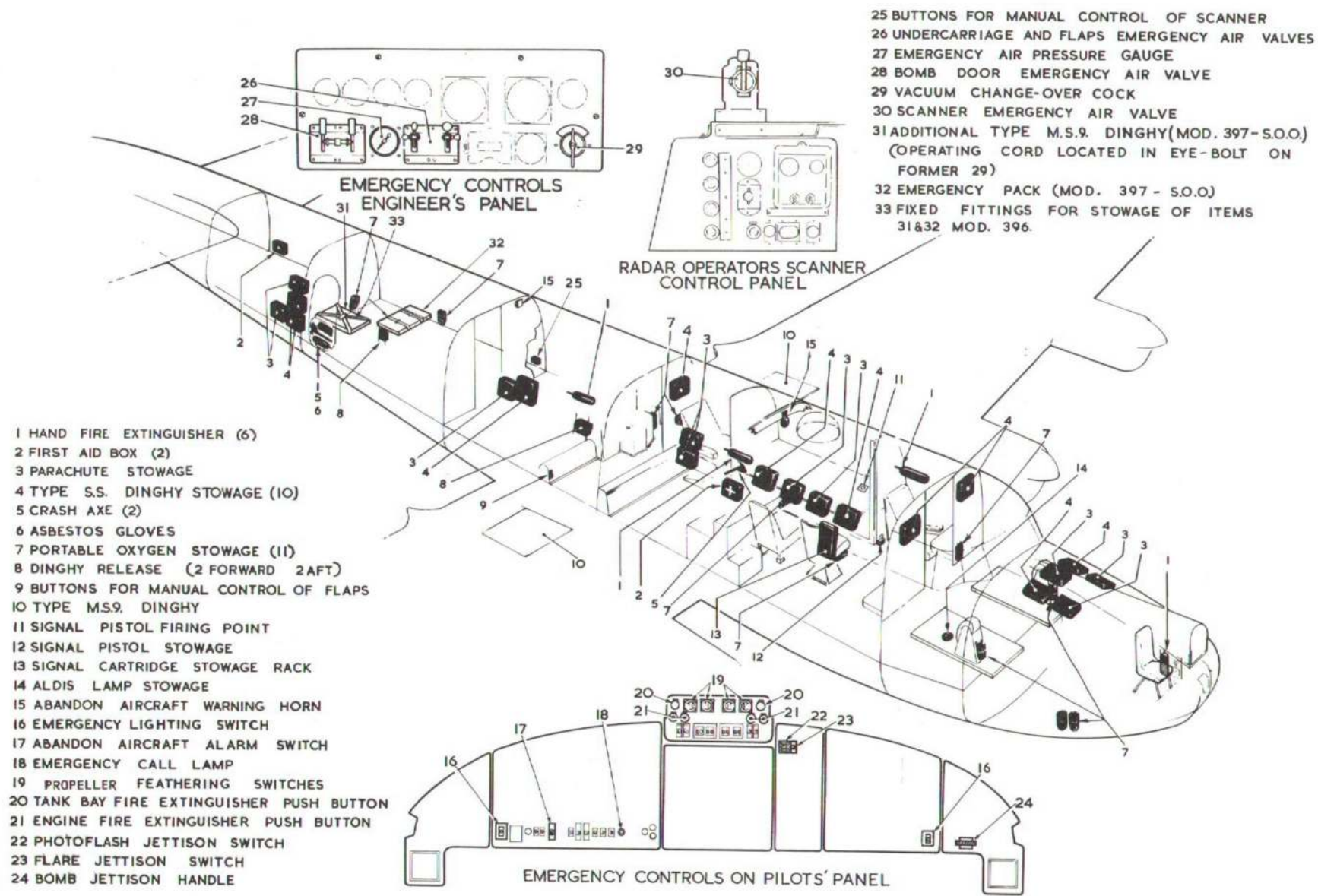

Fig. 1A. Emergency equipment and controls-Phase 2

RESTRICTED

This file was downloaded
from the RTFM Library.

Link: www.scottbouch.com/rtfm

Please see site for usage terms,
and more aircraft documents.

**TELEBRIEF
CONNECTIONS**

E