

Chapter 2 PREPARATION FOR FLIGHT

LIST OF CONTENTS

	Para.		Para.
Location of servicing points ...	1	Emergency air system	10A
Replenishing		Oxygen crate	11
Main fuel tanks	2	Nitrogen system	12
Water/methanol fluid tanks	3	Aircraft master switch and	
Auxiliary fuel tank	4	external supply socket	13
Oil tanks	5	Windscreen anti-misting system ...	14
Hydraulic oil reservoir	6	Alighting gear	15
Windscreen wiper hydraulic pump		Power plants	
reservoir	6A	Engine cooling systems	16
Vision de-icing tank	7	Accessories gearboxes	17
Propeller and aerofoil de-icing		Propeller translation unit oil	
tanks	8	tanks	18
Fresh water tanks	9	Oil dilution system	19
Charging storage bottles		Engine priming	20
Pneumatic system	10		

LIST OF ILLUSTRATIONS

	Fig.
Servicing points	1
Details of servicing points (1) ...	2
Details of servicing points (2) ...	3
Installation of auxiliary fuel	
tank	4

LOCATION OF SERVICING POINTS
(figs. 1, 2 and 3)

1. All points requiring servicing before flight are shown in the illustration. Specifications or Ref. Numbers for fuel, oil, hydraulic oil, de-icing fluids, etc., are stated in Leading Particulars. All tanks must be filled with the aircraft in the tail down attitude.

REPLENISHING

Main fuel tanks

2. Dipsticks for the main fuel tanks are stowed in clips fitted to brackets between two formers aft of the main entrance door. The illustration shows the position of the fillers for the No.1, 2 and 4 tanks. Circular hinged panels provide access to these fillers. Each No.3 tank is filled from the adjacent No.4 tank.

Water/methanol fluid tanks

3. A door on the inboard side of each outboard rear nacelle fairing provides access to the filler neck of the tank inside. No dipsticks are provided for these tanks and they are full when the fluid level is approximately 3½ in. above the lower portion of the filler orifice, measured up the slope of the neck. Use trolley Ref.No. 4G/4422 for filling these tanks.

Auxiliary fuel tank (fig.4)

4. This tank is filled after it is installed. Installation is shown in the illustration and removal is the reverse of installation. When the tank is fitted, the filler neck is at the forward end and is approximately 5 in. below the roof of the bomb compartment, and is inclined to port to enable a refuelling nozzle to be used. A dipstick is fitted to a screw cap at the

top of the tank. This assembly can be removed by withdrawing it through No.15 bomb slip housing after removing the bomb slip cover.

Oil tanks

5. Access doors for the inboard oil tanks are on the top surfaces of the main plane just outboard of No.2 and 3 nacelles, those for the outboard oil tanks on the outboard side of No.1 and of No.4 nacelle. A dipstick for each oil tank is integral with its filler cap.

Hydraulic oil reservoir

6. Access to the filler cap is gained by removing the top cowling panel aft of the No.4 nacelle firewall. The cap has an integral dipstick marked MAX. and MIN. A filter is fitted inside the filler opening and this should be examined for possible damage to ensure that no foreign matter

1. HYDRAULIC OIL RESERVOIR
2. WATER/METHANOL FLUID TANK (one port outboard, one starboard outboard)
3. PROPELLER DE-ICING FLUID TANK
4. EMERGENCY AIR SYSTEM CHARGING POINTS
5. GALLEY WATER TANK
6. GROUND ELECTRICAL SUPPLY POINT
7. NITROGEN SYSTEM CHARGING POINT
8. TAIL-WHEEL UNIT LIQUID SPRING CHARGING
9. TAIL-WHEEL TYRE INFLATION
10. AEROFOIL DE-ICING SYSTEM FLUID TANK
11. INBOARD OIL TANK (one port, one starboard)
12. ACCESSORIES GEARBOX (one in each nacelle)
13. NO. 2 FUEL TANK (one port, one starboard)
14. NO. 3 AND 4 FUEL TANKS (port and starboard)

15. OUTBOARD OIL TANKS (No. 1 and 4 nacelles)
16. COOLANT HEADER TANK (one in each nacelle)
17. SHOCK-ABSORBER STRUT CHARGING AND INFLATION (four)
18. MAIN-WHEEL TYRE INFLATION (port and starboard)
19. PNEUMATIC SYSTEM CHARGING POINT (one port, one starboard)

20. NO. 1 FUEL TANK (one port, one starboard)
21. TRANSLATION UNIT OIL TANK (one for each propeller)
22. AUXILIARY FUEL TANK DIPSTICK (fig. 2)
23. AUXILIARY FUEL TANK FILLER NECK (fig. 2)
24. OXYGEN SYSTEM CHARGING POINT
25. WINDSCREEN DE-ICING FLUID TANK
26. WINDSCREEN WATER-SPRAY TANK
27. FRONT GUNNER'S WINDSCREEN WIPER PUMP UNIT

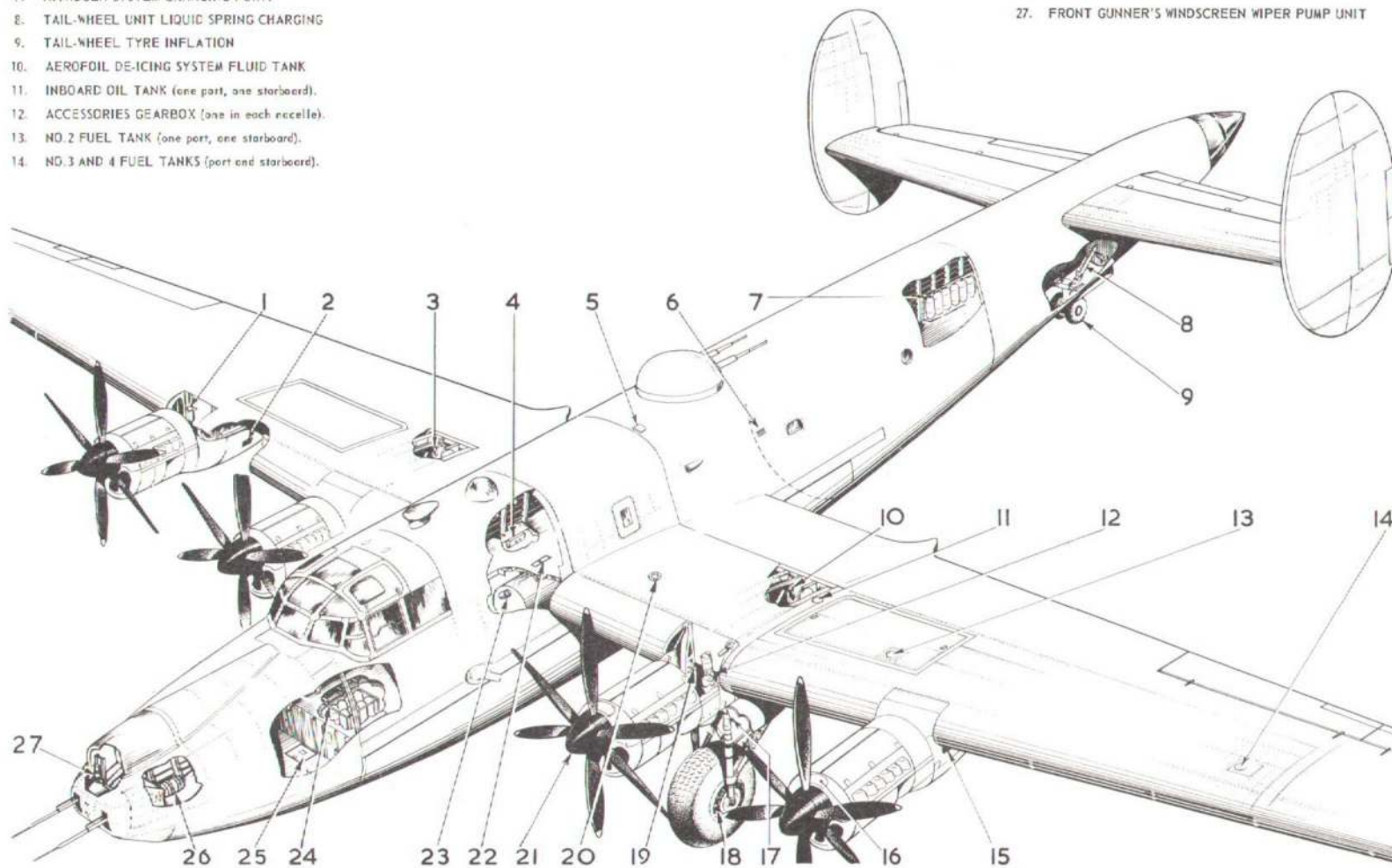

Fig. 1. Servicing points
 (Mod. No. 987)
RESTRICTED

is introduced into the system when filling. A label on the filler cap is inscribed FILL WITH U/C DOWN AND BOMB DOORS CLOSED. Failure to return the hydraulic reservoir two-way cock to the correct position after replenishing the system may cause venting at, and probable damage to the pumps when No.3 and 4 engines are started up. If the oil has fallen to or below the "MIN" mark, the starboard engines are not to be started until the reservoir has been topped up and the hydraulic pumps re-primed.

Windscreen wiper hydraulic pump reservoir

6A. The wiper hydraulic pump, located on the starboard side of the nose section beside the front gunner's seat, has a replenishing point at the base of its forward face. The filler cap is removed by rotating the leaf spring which holds the cap in position. The reservoir is to be filled to within ½ in. of the filler orifice (Sect.3, Chap.6).

Vision de-icing tank

7. A panel in the middle of the floor of the nose just forward of the former E bulkhead can be removed to reach the tank which has a filler at the top, surrounded by an annular depression which serves as a drip tray. Integral with the filler cap is a dipstick graduated in gallons.

Propeller and aerofoil de-icing tanks

8. These are located at the aft end of the two main-wheel compartments and are to be filled to within approximately 1 in. of the top of the filler neck. Use trolley Ref.No.4G/4222 for filling these tanks. With Mod.768 embodied, which utilises the propeller tanks to supplement the aerofoil de-icing, the propeller de-icing system is deleted.

Fresh water tanks

9. A hinged flap on the top of the fuselage just aft of the rear spar is opened

to expose the screw-type filler cap to the galley fresh water tank. This is provided with an annular rim in which are two slots for turning it. Access to the filler cap of the windscreen water-spray tank, located just above floor on the starboard side of the nose section, is gained by lifting the flap of the fibreglass jacket surrounding the tank. Ensure that clean drinking water is used when replenishing the galley tank.

CHARGING STORAGE BOTTLES

Pneumatic system

10. There are two storage bottles for the port system which are charged through a standard A58, Mk.2 connection mounted on a small panel attached to the starboard undercarriage beam of No.2 nacelle. Pre.Mod.392 the single bottle of the starboard system is charged through an identical connection on a similar panel attached to the starboard undercarriage beam of No.3 nacelle. Post Mod.392 the additional bottle in the starboard system is charged from the same connection. The systems are fully charged at a pressure of 1,000 p.s.i.

Emergency air system

10a. Three charging points and three associated pressure gauges will be found in the bomb compartment on the starboard side just forward of the rear spar. If replenishment is required, charge each point with dry compressed air until each associated gauge indicates a pressure of 1,800 p.s.i. Check also that the jettison valve associated with the flaps circuit has been reset as indicated in Sect.3, Chap.6.

Oxygen crate

11. At the forward end of the crate, when it is slung in the aft end of the bomb compartment from the middle

bomb slip, is a charging point. The maximum charging pressure is 1,800 p.s.i. (refer to A.P.1275, Vol.1, Sect.8, Chap.3, for instructions regarding charging the bottles).

Nitrogen system

12. The nitrogen charging point is at the forward end of the storage bottle rack. The bottles are to be charged to a maximum pressure of 1,800 p.s.i. in accordance with the instructions contained in A.P.1275A, Vol.1, Sect.10, Chap.4, which are supplemented by information contained in Sect.4, Chap.6, of this Volume.

AIRCRAFT MASTER SWITCH AND EXTERNAL SUPPLY SOCKET

13. The master switch is located inside the aircraft at the aft end of the main power panel near former 5 and must be switched to GROUND position immediately after the aircraft is parked in order that the indicating circuits of the aircraft may not constitute a drain on the aircraft battery. The external supply socket is accessible outside the aircraft by lifting a hinged panel on the starboard side of the fuselage aft of the bomb compartment.

WINDSCREEN ANTI-MISTING SYSTEM

14. Inspect the activated silica-gel cartridges which are situated forward of the port ammunition box in the nose of the aircraft. If the contents are two-thirds pink instead of wholly blue, the cartridge must be changed. Whilst changing cartridges, ensure that all unions are fully serviceable and afterwards, securely tightened.

ALIGHTING GEAR

15. Inflate the aircraft tyres in accordance with the information given in Volume

RESTRICTED

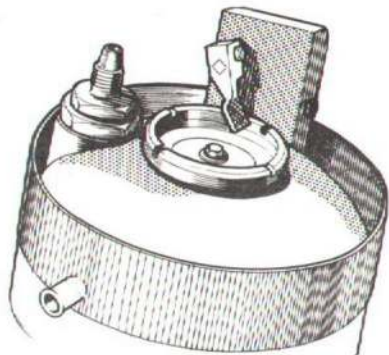

HYDRAULIC RESERVOIR

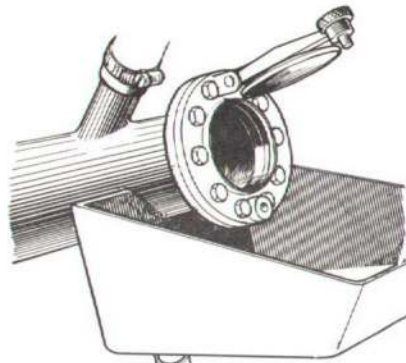

WATER/METHANOL TANK

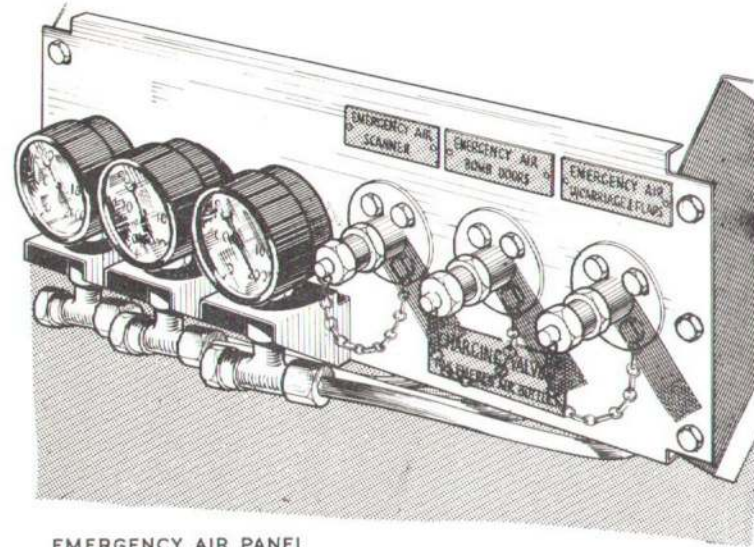

EMERGENCY AIR PANEL

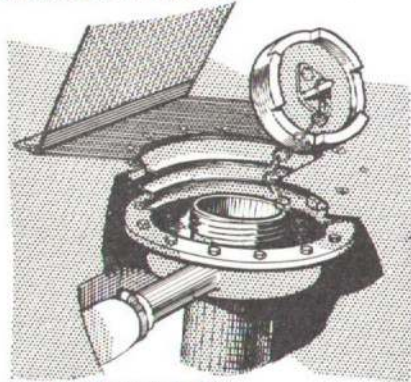

GALLEY WATER TANK

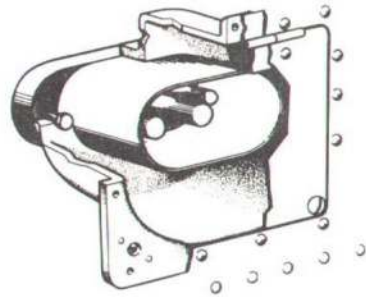

GROUND STARTER SOCKET

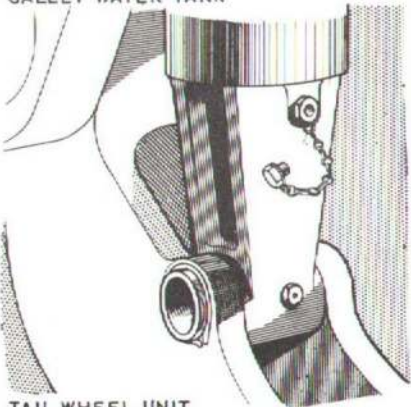

TAIL WHEEL UNIT

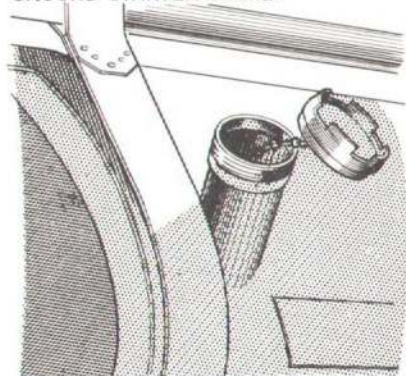

DE-ICING TANK

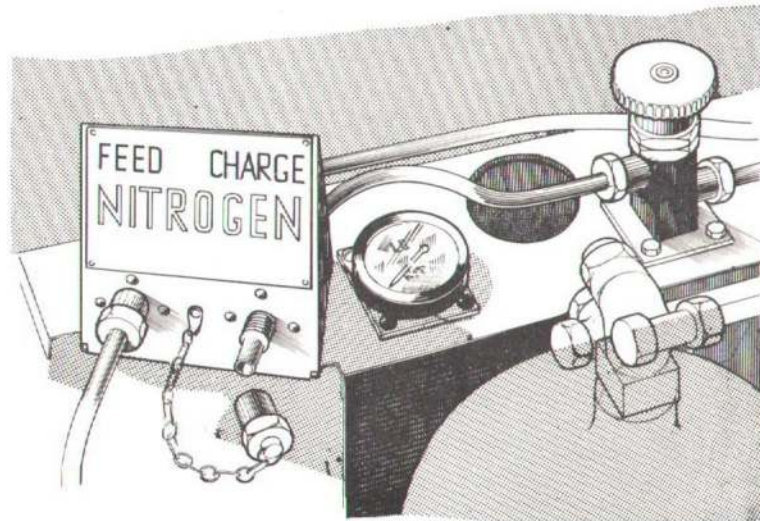

NITROGEN SYSTEM

Fig.2. Details of servicing points(1)

RESTRICTED

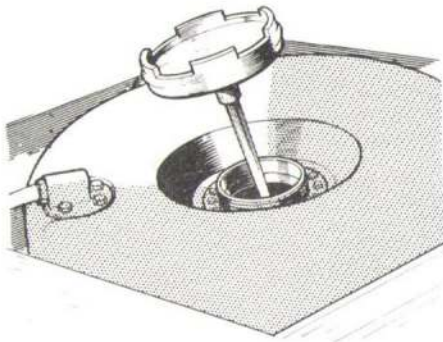

WINDSCREEN DE-ICING TANK

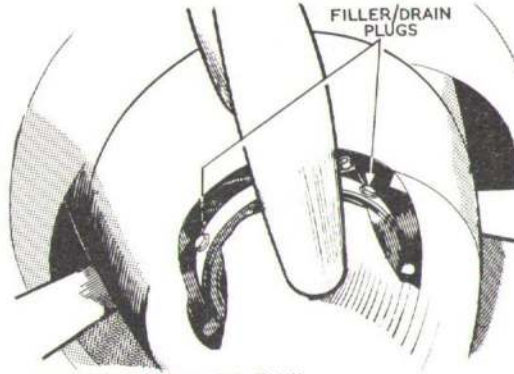

TRANSLATION UNIT OIL TANK

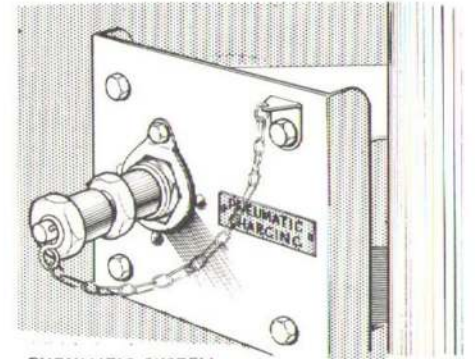

PNEUMATIC SYSTEM

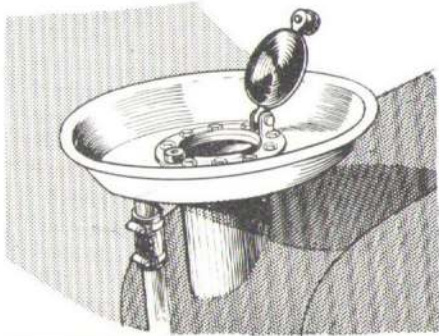

INBOARD OIL TANK

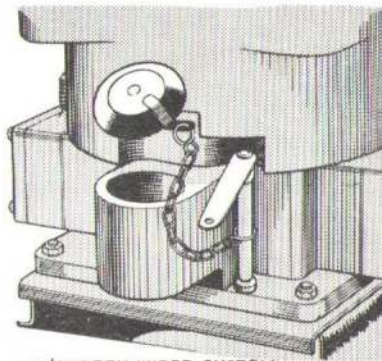

W/SCREEN WIPER SYSTEM

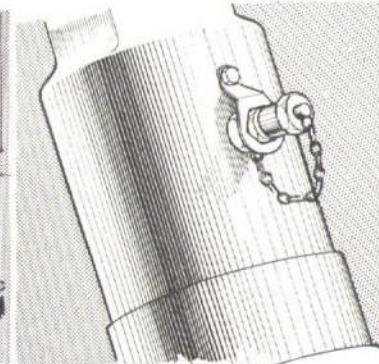

SHOCK-ABSORBER STRUT

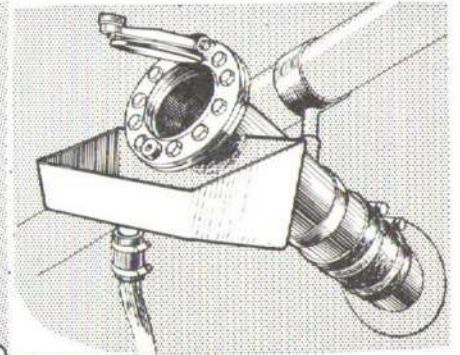

OUTBOARD OIL TANK

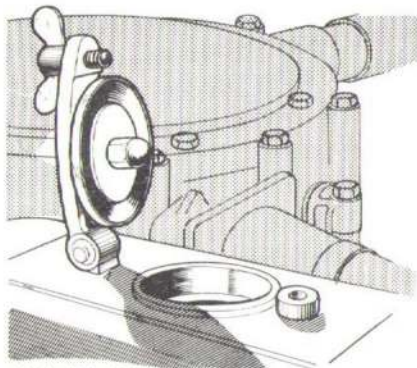

COOLANT HEADER TANK

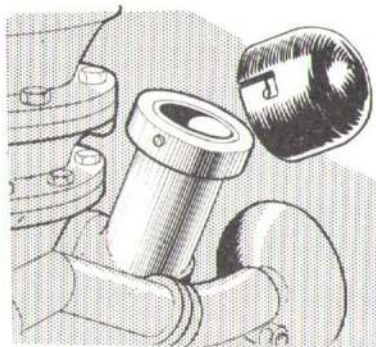

ACCESSORIES GEARBOX



W/SCREEN WATER SPRAY SYSTEM

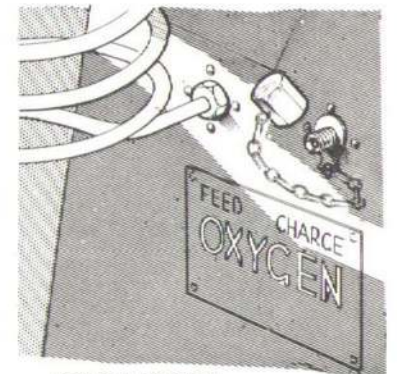

OXYGEN SYSTEM

Fig.3. Details of servicing points (2)

(Mod. No. 987)

RESTRICTED

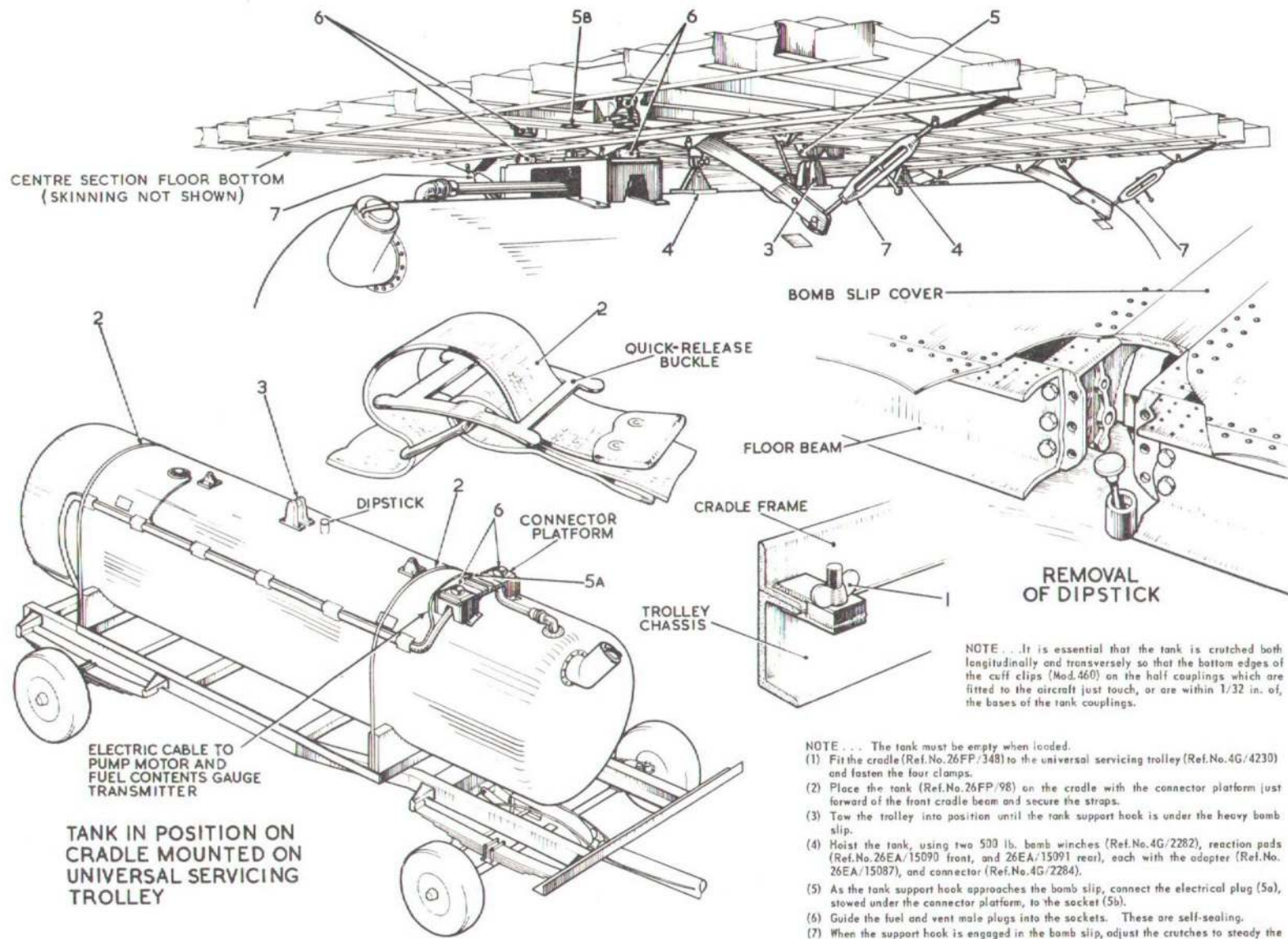

CENTRE SECTION FLOOR BOTTOM
(SKINNING NOT SHOWN)

BOMB SLIP COVER

QUICK-RELEASE
BUCKLE

FLOOR BEAM

CRADLE FRAME

REMOVAL
OF DIPSTICK

ELECTRIC CABLE TO
PUMP MOTOR AND
FUEL CONTENTS GAUGE
TRANSMITTER

TANK IN POSITION ON
CRADLE MOUNTED ON
UNIVERSAL SERVICING
TROLLEY

TROLLEY
CHASSIS

NOTE . . . It is essential that the tank is crutched both longitudinally and transversely so that the bottom edges of the cuff clips (Mod.460) on the half couplings which are fitted to the aircraft just touch, or are within 1/32 in. of, the bases of the tank couplings.

- NOTE . . . The tank must be empty when loaded.
- (1) Fit the cradle (Ref.No.26FP/348) to the universal servicing trolley (Ref.No.4G/4230) and fasten the four clamps.
 - (2) Place the tank (Ref.No.26FP/98) on the cradle with the connector platform just forward of the front cradle beam and secure the straps.
 - (3) Tow the trolley into position until the tank support hook is under the heavy bomb slip.
 - (4) Hoist the tank, using two 500 lb. bomb winches (Ref.No.4G/2282), reaction pads (Ref.No.26EA/15090 front, and 26EA/15091 rear), each with the adapter (Ref.No.26EA/15087), and connector (Ref.No.4G/2284).
 - (5) As the tank support hook approaches the bomb slip, connect the electrical plug (5a), stowed under the connector platform, to the socket (5b).
 - (6) Guide the fuel and vent male plugs into the sockets. These are self-sealing.
 - (7) When the support hook is engaged in the bomb slip, adjust the crutches to steady the tank.

Fig. 4. Installation of auxiliary fuel tank.

RESTRICTED

4 of this Air Publication. Alighting gear shock-absorber strut inflation is described in Sect.3, Chap.5, of this Volume.

POWER PLANTS

Engine cooling systems

16. Take care during removal of the filler caps of the four header tanks unless the cooling systems are cool or cold. When the systems are hot, partially unscrew the wing bolt holding down each filler cap and allow the pressure to escape slowly, before fully releasing the cap. The systems are replenished in accordance with the instructions contained in A.P.1464C, Vol.1. Na. M.B.T. inhibitor is used in these systems.

Accessories gear boxes

17. In each nacelle the oil filler of the gearbox sump is at the port side and is reached by removing the port side panel immediately aft of the firewall. The filler cap is removed by depressing it, twisting it anti-clockwise and lifting it clear. It has an integral dipstick. Use only the oil specified in (Leading Particulars).

Propeller translation unit oil tanks

18. Each propeller oil tank has two plugs on its circumference set 120 deg. apart. Turn the propeller to set these plugs at 10 and 2 o'clock respectively, remove the plugs and syringe the oil (Leading Particulars) into one of the holes until it is about to overflow from the other hole. The tank is then replenished to the correct level and the plugs are refitted and locked with wire.

Oil dilution system

19. An operating push-button for each of the engines is mounted on the flight engineer's auxiliary panel. Operating times are:-

At temperatures down	
to -9 deg.C.	1 min.
At -10 deg.C. and below	2 min.

Engine priming

20. No hand priming system is fitted to this aircraft. Electrically-operated priming valves for the engines are supplied with fuel under pressure by two electric pumps, one port and the other starboard. A five position switch, inscribed, 1, 2, OFF, 3 and 4, is mounted on the flight engineer's auxiliary panel. When the

switch is turned to either 1 or 2, the port pump is operated and when it is turned to 3 or 4, the starboard pump is operated. When the correct pressure has been built up by either motor, one of two red indicating lamps integral with the switch is lit. By pressing in the switch handle the valve to which the handle is pointing is opened and the associated engine is primed. After use, the switch must be returned to the OFF position. If it is not, one of the red lamps will indicate the fact. The system is illustrated in Sect.4, Chap.2. Operating times according to ambient temperature are as follows:-

Prevailing air temp. (deg. centigrade)	Injection period-seconds (100/130 grade fuel)
30	1½
20	2
10	3
5	3½
Zero	4
-5	7½
-10	15
-20	22½
-30	27½

For fuel priming drill associated with starting the engines, refer to A.P.4267B, P.N.



This file was downloaded
from the RTFM Library.

Link: www.scottbouch.com/rtfm

Please see site for usage terms,
and more aircraft documents.

