

Chapter 4

GENERAL SERVICING

LIST OF CONTENTS

DESCRIPTION	Para.		Para.		Para.
<i>Introduction</i>	1	<i>Dismantling</i>	6	GENERAL SERVICING INFORMATION	
<i>List of references</i>	2	<i>Bonding, locking and sealing</i> ...	7	<i>Former and rib positions</i>	13
<i>List of servicing equipment and tools</i>	3	<i>Hydraulic system components</i> ...	8	<i>Access panels</i>	14
DISMANTLING THE AIRCRAFT		<i>Pop-rieveted panels</i>	9	<i>Jacking and slinging for servicing</i>	15
<i>Sections of aircraft</i>	4	<i>Trim tab cables</i>	10	<i>Rigging of fixed surfaces</i>	16
<i>Jacking and trestling complete aircraft</i>	5	ASSEMBLING THE AIRCRAFT		<i>Rigging position</i>	17
		<i>Sequence of assembly</i>	11	<i>Main plane</i>	18
		<i>Assembly panels</i>	12	<i>Tail plane</i>	19

LIST OF TABLES

Table	1	Table	2
<i>List of ground servicing equipment</i>	1	<i>Flight tool kit</i>	2

LIST OF ILLUSTRATIONS

	Fig.		Fig.		Fig.
<i>Sections of aircraft</i>	1	<i>Assembly panels - under surfaces</i>	7	<i>Rigging position and main incidence checks</i>	11
<i>Jacking and trestling</i>	2	<i>Former and rib positions (1)</i> ...	8	<i>Access panels - upper surfaces</i> ...	12
<i>Jacking one main wheel</i>	3	<i>Former and rib positions (2)</i> ...	9	<i>Access panels - under surfaces</i> ...	13
<i>Slings aircraft sections</i>	4	<i>Wing tip, tail plane and fin checks</i>	10	<i>Weatherproofing</i>	14
<i>Weights and packing dimensions of components</i>	5			<i>Walkways</i>	15
<i>Assembly panels - upper surfaces</i>	6				

DESCRIPTION

similar notes on the radio and radar installations in Sect.6.

List of references

2. For servicing notes and information not dealt with in this chapter, reference should be made to the relevant Air Publications, a list of which is given at the beginning of this book.

LIST OF SERVICING EQUIPMENT AND TOOLS

3. Particulars of all special and standard equipment and tools required for servicing the aircraft are contained in Table 1, and a list of items in the flight tools kit in Table 2. These tables do not refer to any items listed in Vol.3, Part 3 (Appendix "A") excepting item 32 in Table 2 which is listed for reference only.

RESTRICTED

Introduction

1. This chapter gives a description of servicing operations of a general nature related to the aircraft as a whole. Parts of these operations are carried out in conjunction with servicing and removal operations in other chapters in this volume and suitable references are made to these chapters where applicable. Servicing notes on the electrical and instrument installations will be found in Sect.5, and

TABLE 1
LIST OF GROUND SERVICING EQUIPMENT

Item	Ref.No.	Part No.	Description	Application
TOWING AND STEERING EQUIPMENT (CHAP.1)				
Standard equipment				
1	4G/4139	GS.2151	Bridle, forward towing	At main wheels
Special equipment				
2	26FP/333 ✓	1/U939	Arms, towing	At tail wheel
4	26FP/353	1/U1010	Arms, steering, tail wheel	For use with bridle.
5	26FP/301	1/U813	Cables, towing bogged aircraft	At main wheel
6	26FP/352	U1007	Adapter, towing arm, Mk.2	
JACKING EQUIPMENT (FIG.2)				
Standard equipment				
10	4Q/1309 ✓	-	Jack, 8 ton pillar Type B	Post Mod.272 tail-wheel jacking
11	4Q/2320 ✓	-	Adapter, Mk.26	Used with item 10 and 19
13	4Q/2610 ✓	-	Jack body, hydraulic, 25 ton.	At main plane
14	4Q/2612 ✓	-	Trestle Mk.2, 25 ton	Used with item 13 and 15
15	4Q/2616 ✓	-	Adapter,head, Mk.45	Used with item 13 and 14
16	4Q/2614 ✓	-	Units, fixed leg	Wheel transportation
17	4Q/2615 ✓	-	Units, trailing leg	Wheel transportation
Special equipment				
18	26EA/33069 ✓	2/U796	Jacking pads, main plane	Used with item 13, 14 and 15
19	26FP/372 ✓	U1087	Stand, jacking	Used with item 10 and 11
19a	26FP/381 ✓	U1083	Clamp, jury	Tail-wheel leg
TRESTLING EQUIPMENT (FIG.2)				
Standard equipment				
20	4G/-	-	Trestle U.J. No.9A	Former E
21	4G/-	-	Trestle U.J. No.11	Former 33 and tail plane
22	4G/-	-	Trestle U.J. No.12	Former 29
23	4G/-	-	Trestle U.J. No.15	Former 41, rigging position
24	4G/-	-	Trestle U.J. No.17	Former 41 scanner testing

NOTE . . .

All the above to be completed with brackets Type A and used with items overleaf (26 to 38)

RESTRICTED

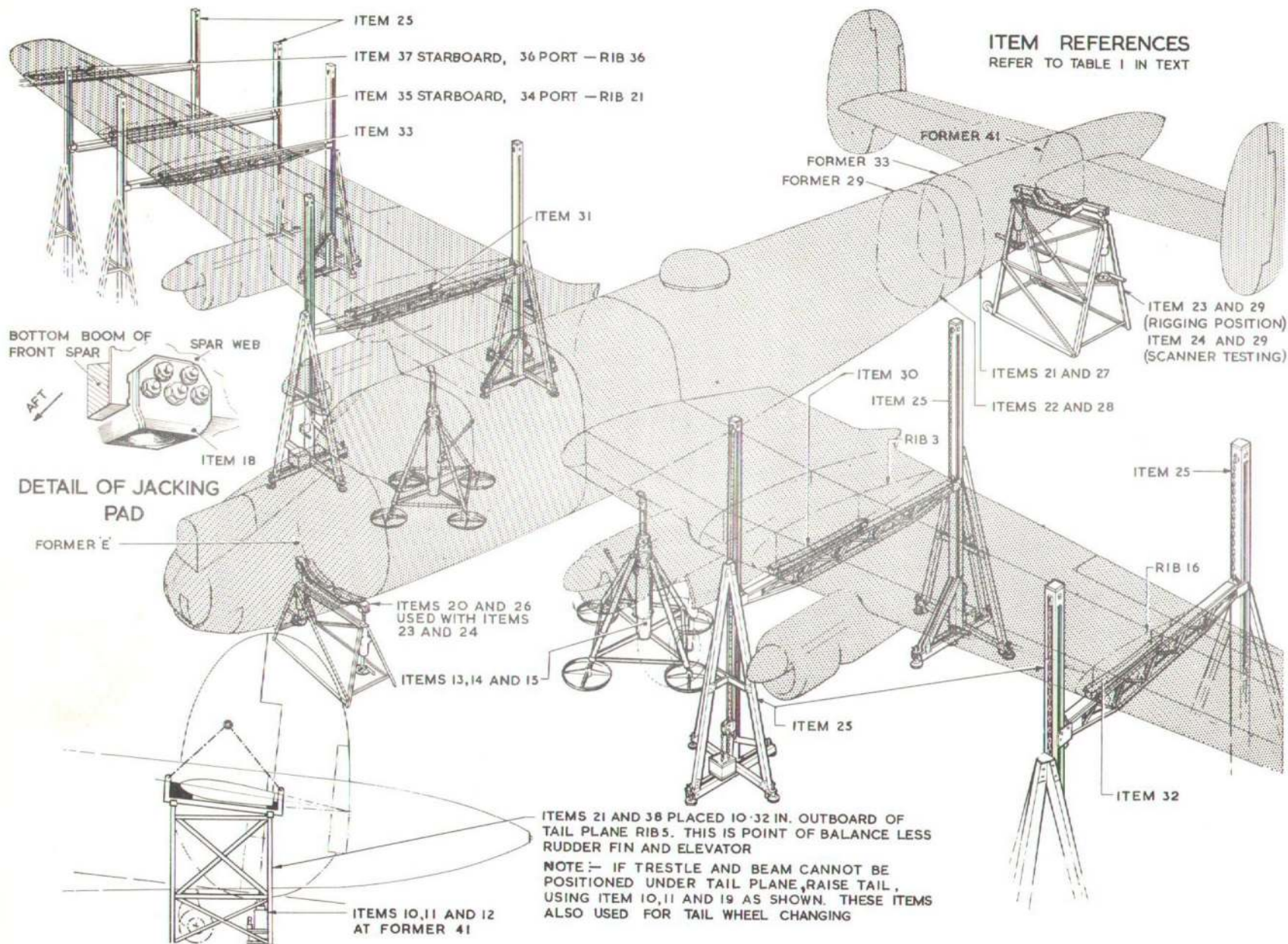

Fig. 2. Jacking and trestling

RESTRICTED

TABLE 1 cont.

Item	Ref.No.	Part No.	Description	Application
25	-	-	Gantry lifting heavy Consisting of:-	
	4Q/2309	-	(a) Uprights, Type A	Used with items 30 to 37
	4Q/2310	-	(b) Beams, Type A	Used with items 30 to 37
	4Q/2311	-	(c) Beams, Type B	Used with items 30 to 37
Special equipment				
26	26FP/314	U900	Beam, former E	Used with item 20
27	26FP/304	U891	Beam, former 33	Used with item 21
28	26FP/332	U896	Beam, former 29	Used with item 22
29	26FP/303	U890	Beam, former 41	Used with item 23 and 24
30	26EA/32091	1/U739	Beam, wing rib 3, port	Used with item 25
31	26EA/32108	2/U739	Beam, wing rib 3, starboard	Used with item 25
32	26EA/32109	1/U765	Beam, wing rib 16, port	Used with item 25
33	26EA/32110	2/U765	Beam, wing rib 16, starboard	Used with item 25
34	26EA/32111	1/U766	Beam, wing rib 21, port	Used with item 25
35	26EA/32112	2/U766	Beam, wing rib 21, starboard	Used with item 25
36	26EA/32113	1/U767	Beam, wing rib 36, port	Used with item 25
37	26EA/32114	2/U767	Beam, wing rib 36 starboard	Used with item 25
38	26FP/330	U921	Beam, tail plane	Used with item 21
SLINGING EQUIPMENT				
Special equipment				
39	26FP/493	U1578	Beam, scanner slinging	Used with item 52 and 53
40	26FP/305	5/U883	Eyebolt, slinging	Used with item 46 and 47
41	26FP/306	U882	Sling	Centre section
42	26FP/355	U991	Sling	Nose and front centre section with guns and mountings
43	26FP/354	U995	Sling	Nose section
44	26FP/309	U876	Sling	Front centre section Nose and front centre section less guns and mountings. Rear centre section with turret.
45	26FP/356	U994	Sling	Rear centre section less turret
46	26FP/357	U992	Sling	Rear section
47	26FP/312	U887	Sling	Tail lifting to rigging position
48	26EA/32088	U760	Sling	Intermediate plane section
49	26EA/32089	2/U760	Sling	Outer plane section
50	26FP/315	U907	Sling	Fin or rudder
51	26FP/316	U918	Sling	Tail plane
52	26FP/351	-	Eyebolt, slinging	For scanner unit
53	26FP/375	U1091	Sling	Scanner Type 85

RESTRICTED

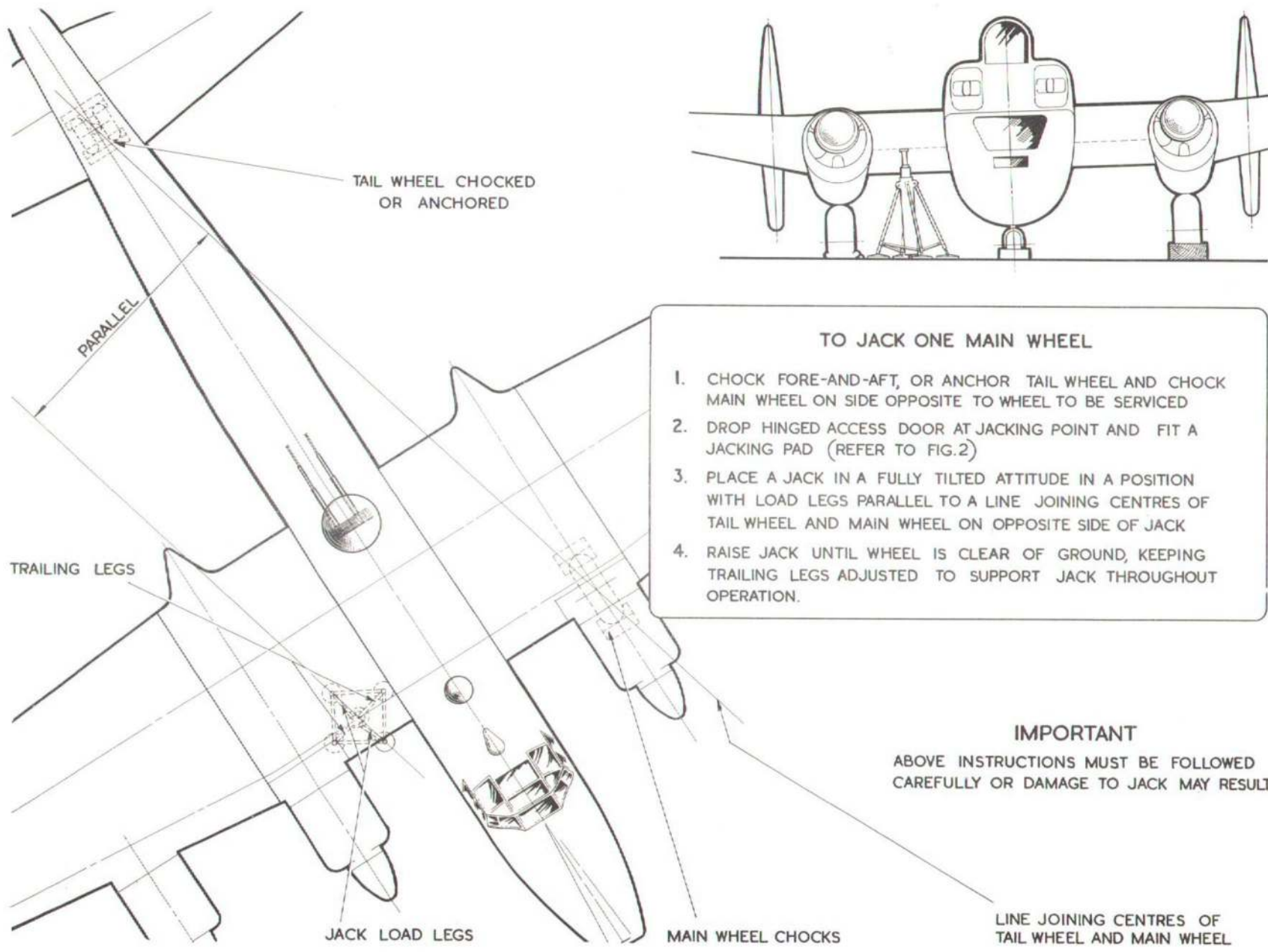

TAIL WHEEL CHOCKED
OR ANCHORED

PARALLEL

TRAILING LEGS

JACK LOAD LEGS

MAIN WHEEL CHOCKS

- TO JACK ONE MAIN WHEEL**
1. CHOCK FORE-AND-AFT, OR ANCHOR TAIL WHEEL AND CHOCK MAIN WHEEL ON SIDE OPPOSITE TO WHEEL TO BE SERVICED
 2. DROP HINGED ACCESS DOOR AT JACKING POINT AND FIT A JACKING PAD (REFER TO FIG.2)
 3. PLACE A JACK IN A FULLY TILTED ATTITUDE IN A POSITION WITH LOAD LEGS PARALLEL TO A LINE JOINING CENTRES OF TAIL WHEEL AND MAIN WHEEL ON OPPOSITE SIDE OF JACK
 4. RAISE JACK UNTIL WHEEL IS CLEAR OF GROUND, KEEPING TRAILING LEGS ADJUSTED TO SUPPORT JACK THROUGHOUT OPERATION.

IMPORTANT

ABOVE INSTRUCTIONS MUST BE FOLLOWED CAREFULLY OR DAMAGE TO JACK MAY RESULT

LINE JOINING CENTRES OF
TAIL WHEEL AND MAIN WHEEL

Fig.3. Jacking one main wheel

RESTRICTED

TABLE 1 cont.

Item	Ref.No.	Part No.	Description	Application
POWER PLANT CHANGING EQUIPMENT				
Standard equipment				
60	4L/2015	-	Block, pulley, 2 ton	-
61	4G/4170 K	-	Sling	Power plant
62	4G/2350 +	-	Sling	Griffon engine
63	4G/1	-	Stand engine erecting Type A	-
64	4G/2421	-	Sets, modification	Used with item 63 and 65
65	4G/4349	-	Adapter, Type B	Used with item 63 and 64
66	40B/1014 K	-	Stand, power plant, Type D modified	-
67	40B/475	-	Backplate, Type A, No.1	Used with item 66 and 68
68	40B/337	2001/47	Adapter, Type 1 (top)	Used with item 66 and 67
69	40B/1059	-	Adapter, Type 1A (bottom)	Used with item 66 and 67
Special equipment				
70	26EA/32084 * *	U746	Gantry	Power plant changing
71	26FP/344 x	U969	Strut extension, outer	For propeller changing, used with item 70
72	26FP/345 x	U970	Strut extension, inner	For propeller changing, used with item 70
73	26FP/317 x	U916	Platform	Gantry erecting
74	26FP/318 x	U908	Mat, inboard nacelle	
75	26FP/319 <	U906	Mat, outboard nacelle	
INSTALLATION EQUIPMENT				
Standard equipment				
80	4G/4230 *	-	Trolley, basic chassis	Auxiliary fuel tank
Special equipment				
82	26FP/348	U956	Frame support	Used with item 80
COMPONENT HANDLING AND STORAGE EQUIPMENT				
Special equipment				
85	40E/400	-	Cradle, transport	Port radiator
86	40E/401	-	Cradle, transport	Starboard radiator
87	26FP/346	JD2545	Cradle, lifting	Port radiator
88	26FP/347	JD2546	Cradle, lifting	Starboard radiator
89	26FP/331	U923	Frame, storage	Mid turret fairing

RESTRICTED

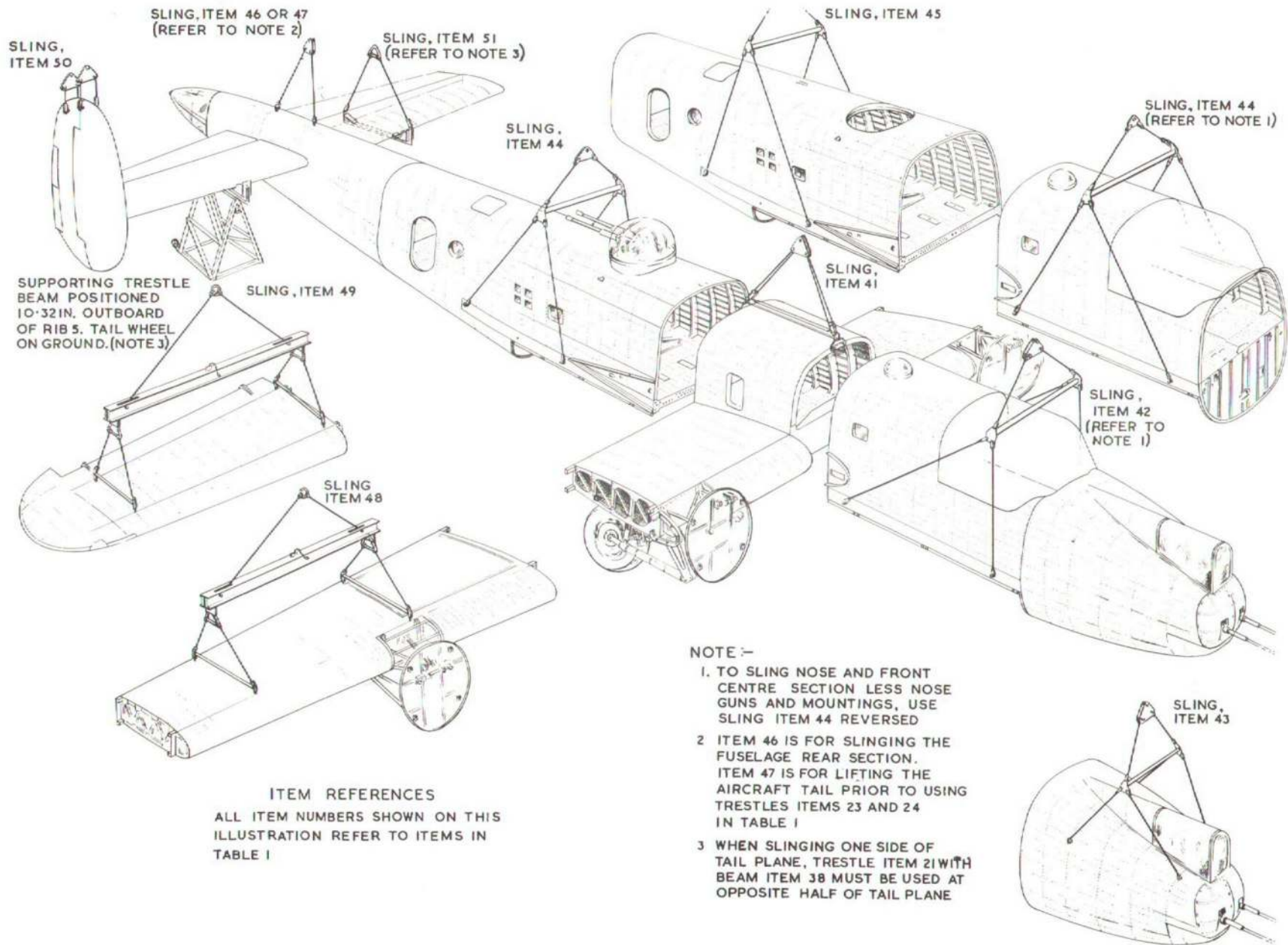

ITEM REFERENCES
ALL ITEM NUMBERS SHOWN ON THIS ILLUSTRATION REFER TO ITEMS IN TABLE I

- NOTE :-
1. TO SLING NOSE AND FRONT CENTRE SECTION LESS NOSE GUNS AND MOUNTINGS, USE SLING ITEM 44 REVERSED
 2. ITEM 46 IS FOR SLINGING THE FUSELAGE REAR SECTION. ITEM 47 IS FOR LIFTING THE AIRCRAFT TAIL PRIOR TO USING TRESTLES ITEMS 23 AND 24 IN TABLE I
 3. WHEN SLINGING ONE SIDE OF TAIL PLANE, TRESTLE ITEM 21 WITH BEAM ITEM 38 MUST BE USED AT OPPOSITE HALF OF TAIL PLANE

Fig.4. Slinging aircraft sections
RESTRICTED

TABLE 1 cont.

Item	Ref.No.	Part No.	Description	Application
RIGGING EQUIPMENT				
90	26EA/3848	Z1275	Gauge, incidence	Main plane centre section
91	26EA/32093	Z2750	Gauge incidence	Main plane, rib 3
92	26EA/32094	Z2751	Gauge, incidence	Main plane, rib 16
93	26EA/32095	Z2752	Gauge, incidence	Main plane, rib 21
94	26EA/32096	Z2753	Gauge, incidence	Main plane, rib 36
95	26EA/32098	Z2754	Gauge, wing tip setting	Main plane, rib 39
96	26EA/32097	Z2765	Gauge, dihedral	Main plane, rear spar
97	26FP/320	Z4899	Gauge, incidence	Tail plane, rib 3
98	26FP/321	Z4900	Gauge, incidence	Tail plane, rib 11
99	26FP/322	Z4906	Pegs, rigging check	Fuselage rear centre section
100	26FP/323	Z4902	Straight edge, transverse check	Fuselage former 37
101	26FP/324	Z4901	Straight edge, transverse check	Fuselage former 14
102	26EA/4319	Z1427	Straight edge, longitudinal check	Fuselage, rear centre section
103	26FP/325	Z4911	Gauge setting	Elevator, rib 4
104	26FP/326	Z4903	Gauge, checking	Fin
105	26FP/327	Z4910	Gauge, setting	Rudder

MISCELLANEOUS SERVICING EQUIPMENT

Standard equipment

110	4G/6246	-	Adapter, inflation Mk.2	Used with item 114
111	4G/3026	-	Gauge, 0-600 lb./sq.in.	Used with item 110
112	4G/3027	-	Gauge, 0-1,500 lb./sq.in.	Used with item 110
113	4G/3029	-	Gauge, 0-3,500 lb./sq.in.	Used with item 110
114	4G/257	-	Pump, oleo, Type A	Shock-absorber strut inflation
115	4G/4269	-	Primer, oil Mk.2	
116	4G/4243	-	Ladder, servicing, Mk.2	
121	4G/4342	-	Mats, main plane, Type C	
122	4G/2596	-	Platform, inspection, Type M	
124	4G/2604	-	Platform, inspection, Type N	
128	33C/1115	-	Outfit, engine coolant	
129	4G/4042	-	Trolley, stowage	For engine and P/P cowlings
130	4G/4200	-	Trolley, engine coolant	For replenishing
131	4G/4422	-	Trolley, water/methanol	
132	4G/4423	-	Trolley, de-icing fluid	
133	4G/4221 or 5888	-	Trolley, H.P. air charging Mk.2	
134	4F/1718	-	Trolley, starting, Mk.5	
135	4F/1693 or 1783	-	Trolley, compressor, air, Type L, Mk.2 or Mk.2A	
136	4F/1913	-	Trolley, electrical servicing and testing, Mk.4	

RESTRICTED

TABLE 1 cont.

Item	Ref.No.	Part No.	Description	Application
137	4F/1796	-	Trolley servicing, hydraulic Mk.2A	
138	4F/1715 or 1856	-	Trolley, instrument and auto-pilot testing Mk.1A	
139	4F/1805	-	Trolley, servicing, pneumatic L.P. Mk.1B	
140	4A/1757	-	Tank, aircraft cowling washing, large	
141	4G/4169	-	} Cleaners, vacuum, aircraft, heavy duty Mk.1A and 1B respectively	} Mk.1A petrol engine Mk.1B - 400/440v, 3 ph., 50 cycles
142	4G/4519	-		
Special equipment				
150	26EA/32107	AH.8364	Extractor wheel	
152	26EA/4274	U575	Ladder, maintenance	
153	26FP/313	U314	Struts, main wheel	
154	26FP/433	U1159	Adapter	Front and rear air conditioning intake No.1
155	26FP/328	U889	Struts, bomb doors, jury	
SALVAGE EQUIPMENT				
160	26FP/430	U1127	Jacking pads, front	} Aircraft salvage Aircraft salvage
161	26FP/431	U1128	Jacking pads, rear	

TABLE 2
FLIGHT TOOL KIT

Item	Ref.No.	Part No.	Description	Application
Special tools				
1	26EA/32635	Z2877	Spanner, wing attachment	Front spar - inboard joint.
2	26EA/32636	Z2878	Spanner, wing attachment	Rear spar - inboard joint,
3	26EA/16996	Z2501	Spanner, wing attachment	Both spars - outboard joint
4	26EA/3819	Z1268	C-spanner	Flap operating system ball joint connectors
5	26EA/33015	Z3847	Extractor	Flap link pins
7	26EA/33017	Z3956	Spanner	Aileron hinge bolts
8	26EA/19842	Z6053	Pop rivet drill	
10	26FP/363	Z6130	Claw spanner, 1/8 in. B.S.F.	Hydraulic connections at wing root panels on front centre section
11	26FP/364	Z6131	Claw spanner, 1/4 in. B.S.F.	Hydraulic connections at wing root panels on front centre section
12	26FP/365	Z6312	Claw spanner, 3/8 in. B.S.F.	Hydraulic connections at wing root panels on front centre section
13	26FP/366	Z6133	Claw spanner, 5/8 in. B.S.F.	Hydraulic connections at wing root panels on front centre section
14	-	29/O3453	Handle assembly	
15	-	18/O3453	Shaft assembly	
16	26FP/367	Z6880	Box key	For engine tuning
17	26FP/369	Z6887	Spanner	Spark plug nut on cabin heaters.
18	26FP/368	Z6888	Spanner	Starter motor connections
19	26FP/371	Z6925	Extractor	Spark plug lead on cabin heaters
20	-	Z7341	Box spanner	Rudder hinge bracket bushes Tail plane centre joint

RESTRICTED

TABLE 2 cont.

Item	Ref.No.	Part No.	Description	Application
21	-	Z7190	Spanner	Aircraft battery attachment nuts
22	-	Z7266	Tubular peg spanner	Spindle stop nut in oil filter
23	26EA/32641	1Z/3245	Spanner, 1.7 in. A/F, 7½ deg.	
24	26EA/32642	2Z/3245	Spanner, 1.7 in. A/F, 22½ deg.	
25	26EA/32643	1/Z3246	Spanner, 2.06 in. A/F, 7½ deg.	
26	26EA/32644	2Z/3246	Spanner, 2.06 in. A/F, 22½ deg.	
27	26EA/32638	Z3254	Spanner, 2.24 in. A/F, straight	
28	26EA/32645	Z3247	Spanner, 1.9 in. A/F, straight	
29	26EA/32649	Z3251	Spanner, 1.16 in. A/F, straight	
30	26EA/32637	U779	Spanner, 2 B.A. universal jointed	
31	26FP/362	Z6063	Spanner, 1.875 in. A/F, straight	
32	* 26EA/4306	Z1436	Spanner	Radiator drain plug
34	26EA/32107	AH8364	Extractor	Wheels
Standard items				
40	1L/10	-	Ratchet handle 3/8 in. sq. drive	
41	1A/4105	-	Tommy bar	Used with item 42
42	1C/2229	-	Box spanner, 1/8 in. x 3/16 in. Whit.	
43	1L/48	-	Extension bar 1/2 in. sq. drive x 9 in.	
44	1B/4467	-	Universal lubricating gun	
45	1L/50	-	Ratchet handle 1/2 in. sq. drive	
46	1L/137	-	Ratchet handle 9/32 in. sq. drive	
47	1L/9	-	Swivel handle 9/32 in. sq. drive x 6 in.	
48	1B/4463	-	Miniature nozzle	Used with item 44
49	1B/4468	-	Pull-on nozzle	Used with item 44
50	3A/1854	-	Riveters, Type P.G.O.3	Hydraulically operated
51	1L/45	-	Bi-hexagonal socket, 11/16 in. Whit.	
52	1L/136	-	Hexagon socket, 7/16 in. A/F.	
* This item is included in the appendix 'A', but is included in this list for convenience of reference.				
53	1L/59	-	Open jaw spanner 9/16 in. x 5/8 in. Whitworth. 11 in. long.	
54	1L/73	-	Open jaw spanner 11/16 in. x 3/4 in. Whitworth. 12½ in. long.	
55	1C/6436	-	Single ended spanner 1½ in. A/F	
56	1C/229	-	Box spanner 1/8 in. x 3/16 in. Whitworth	
57	1C/6452	-	Automatic spiral screwdriver	
58	1C/2167	-	Common screwdriver 18 in. long.	
59	3A/1855	-	Tools for servicing item 50.	
60	1B/4428	-	Circlip pliers, flap links	
61	3A/1854	-	Pop riveter and pump	
62	1C/6182	-	Adjustable C-spanner	

SECTIONS OF AIRCRAFT (fig.1)

4. The illustration shows the sections into which the aircraft can be dismantled and is keyed with references to the chapters in this volume in which relevant

DISMANTLING THE AIRCRAFT

information is to be found.

JACKING AND TRESTLING COMPLETE
AIRCRAFT (fig.2)

5. Equipment used to support the

complete aircraft is indicated on the illustration, and the item numbers refer to the equipment listed in Table 1 under the same numbers. When dismantling the aircraft to a stage where the rear or front

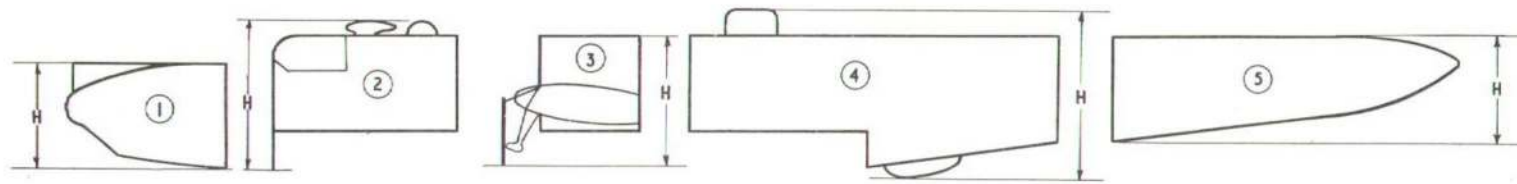

NOTE:- FOR WEIGHT OF EACH COMPONENT REFER TO THE KEY TO THIS ILLUSTRATION

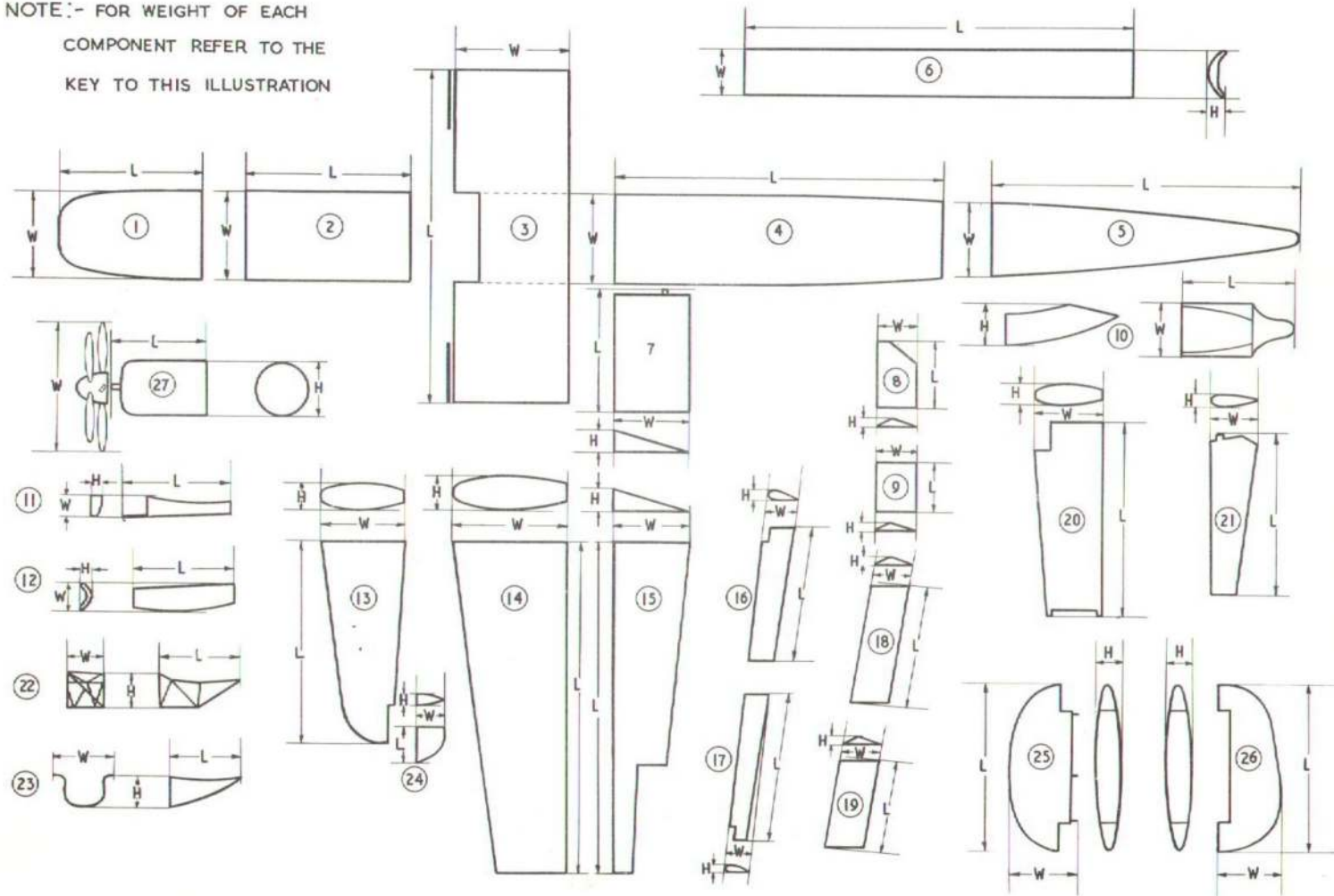

Fig.5. Weights and packing dimensions of components

RESTRICTED

KEY TO FIG.5
(WEIGHTS AND PACKING DIMENSIONS OF COMPONENTS)

Item	Component	Weight (lb)	Height (ft)	Length (ft)	Width (ft)
1	Nose with equipment and gun mounting	1635	8.0	11.75	7.5
2	Front centre section with equipment	3873	11.66	13.5	8.0
3	Intermediate centre section with equipment	6726*	9.5	28.75	7.75
4	Rear centre section with equipment and turret	4857	13.25	27.1	8.0
5	Rear section with equipment	1100*	8.5	27.75	6.25
6	Bomb door	355	1.33	33.25	5.0
7	Centre plane trailing edge	230	3.0	10.5	6.5
8	Inner flap	25	0.5	5.66	3.5
9	Dummy flap	14	0.5	4.75	3.5
10	Inboard rear nacelle fairing	51	3.5	10.5	4.75
11	Valance	20	0.5	9.75	2.0
12	Undercarriage door	36	1.0	9.0	3.0
13	Outer wing section	393	1.5	17.0	7.5
14	Intermediate wing section	2728	3.0	29.0	9.75
15	Intermediate trailing edge	428	2.75	29.0	6.5
16	Inboard aileron section	89	0.75	12.0	3.33
17	Outboard aileron section	69	0.75	13.5	2.5
18	Outer flap	53	0.5	12.33	3.5
19	Outer flap extension	28	0.5	7.0	3.5
20	Tail plane	327	1.5	17.0	7.5
21	Elevator	165	0.75	13.25	4.0
22	Outboard sub-frame	206	3.5	8.0	3.25
23	Outboard rear nacelle fairing	33	4.0	7.0	5.0
24	Detachable wing tip	11	0.5	3.25	2.5
25	Fin	165	1.0	14.5	6.0
26	Rudder	155	1.0	14.5	5.25
27	Power plant (refer to A.P.4275A, Vol.1)	3940	5.0	8.5	13.25

* NOTE:- Weight given for component less undercarriage units.

centre section is to be parted from the intermediate centre section, or a new nose is to be fitted, reference to fig.4 will indicate the slings to be used and it should be realised that it is impracticable to employ jacking trestles along the bomb compartment. When any of the above components are removed, support must be provided for the remainder as follows:-

- (1) Removal of nose: support the rear end of the fuselage at former 41,

or 29 if the rear fuselage has been removed. Normally this section is removed with the front centre section.

- (2) Removal of front centre section with or without nose: support as in (1) above.
- (3) Removal of rear centre section: this must be effected only when the two previous sections are attached to the intermediate centre

section. Steady these three sections, by using a nose steady-ing trestle as indicated in the illustration, before removing the rear centre section.

DISMANTLING

6. Complete dismantling of an aircraft for packing and transport is done in the reverse order to that given in para.11. The slings, to be used on the various major sections of the aircraft, are indicated in fig.4, on which the item numbers given against the slinging equipment used, refer to correspondingly numbered items in Table 1. Packing sizes and weights of components are given in fig.5 and its associated key.

Bonding, locking and sealing

7. Details of bonding, locking and sealing should be carefully noted, especially the arrangement of locking wire to ensure correct restoration when affected components are reassembled or reinstalled. A description of bonding will be found in A.P.1464D, Chap.1.

Hydraulic system components

8. Before disconnecting any union, other than self-sealing couplings, the system must be depressurised by operating the appropriate valve at the top of the reservoir. (Sect.3, Chap.6).

Pop-riveted panels (fig.6 and 7)

9. Pop rivets securing assembly panels must be drilled out before the panels can be removed, using drill, Ref.No.26EA/19842, which is constructed to prevent the rivets turning whilst being drilled. After drilling, the rivets should be punched out.

Trim tab cables

10. When disconnecting a cable, weights or some system of tying should be used to prevent the cable unwinding from the control box and from the aileron trim gear drums.

RESTRICTED

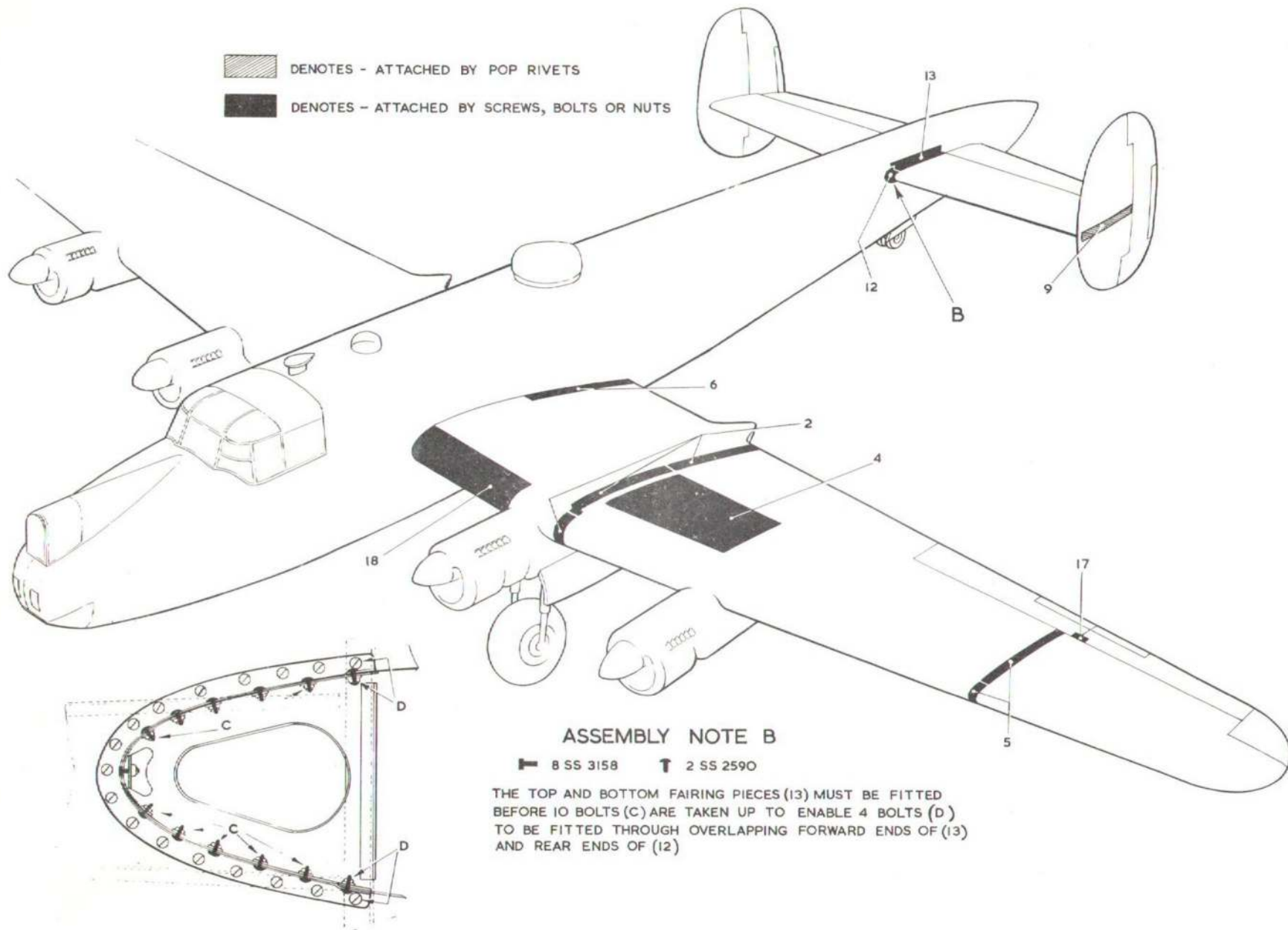



Fig.6. Assembly panels - upper surfaces

RESTRICTED

KEY TO FIG 6 and 7 (ASSEMBLY PANELS)

Item	Description and Purpose	Screws	Bolts	Pop Rivets
1	No. 1 fuel tanks assembly panel	26EA/33049(20) 26EA/33050(42) 26EA/18720(54) 26EA/18721(43) 26EA/19276(57) 26EA/19277(55)	— — — — — —	— — — — — —
	Note.—Fit screws until $\frac{1}{4}$ — $\frac{3}{8}$ in. proud, apply Plastic Hermatite, Stores Ref. 33C/1093, to exposed shanks and underside of heads, and tighten			
2	Inner wing joint assembly panels, nose and top surface	26EA/51	—	—
3	Inner wing joint assembly panel, bottom surface	5/SS.3158	—	—
4	Assembly panel, No. 2, 3 and 4 fuel tanks	—	28D/9326 & 10084	—
5	Outer wing joint assembly panels—Nose	—	28D/8300	—
	Top	5/SS.3158	28D/8341	—
	Bottom	5/SS.3158	28D/8306	—
6	Assembly panels, fuselage to trailing edge	5/SS.3158	—	—
7	Assembly panels, attaching centre plane trailing edge	—	28D/8484	28Q/9517 (Forward edge) and 9374 (Rear edge and ribs)
8	Assembly panels, nuts securing wing tips to rear spar	26EA/50	—	—
9	Assembly panels, fins to tail plane	—	—	3, 4 and 7/SS.3790
10	Access panel, engine controls and services, front spar	—	—	28Q/9275
11	Assembly panels (4) tail plane to fuselage	26EA/576	—	—
12	Nose fairing, tail plane to fuselage	26EA/766	—	—
13	Joint fairing pieces, tail plane to fuselage	26EA/12511	28D/9588 28D/9353	— —
14	Assembly panels (4), transport joint bolts at longerons	—	—	28Q/9192, 9366, 9870
15	Assembly panels (4), attaching intermediate trailing edge	—	—	28Q/9374
16	Assembly panels, rudder control bell cranks	—	—	5/SS.3158
17	Assembly cover, aileron control linkage	—	28D/9853	—
18	Assembly panel, services on front spar	Secured by nuts to front spar		

-  DENOTES - ATTACHED BY POP RIVETS
-  DENOTES - ATTACHED BY SCREWS, BOLTS OR NUTS

THE SCREWS SPECIFIED MUST
BE USED - NO ALTERNATIVES
ARE PERMISSIBLE

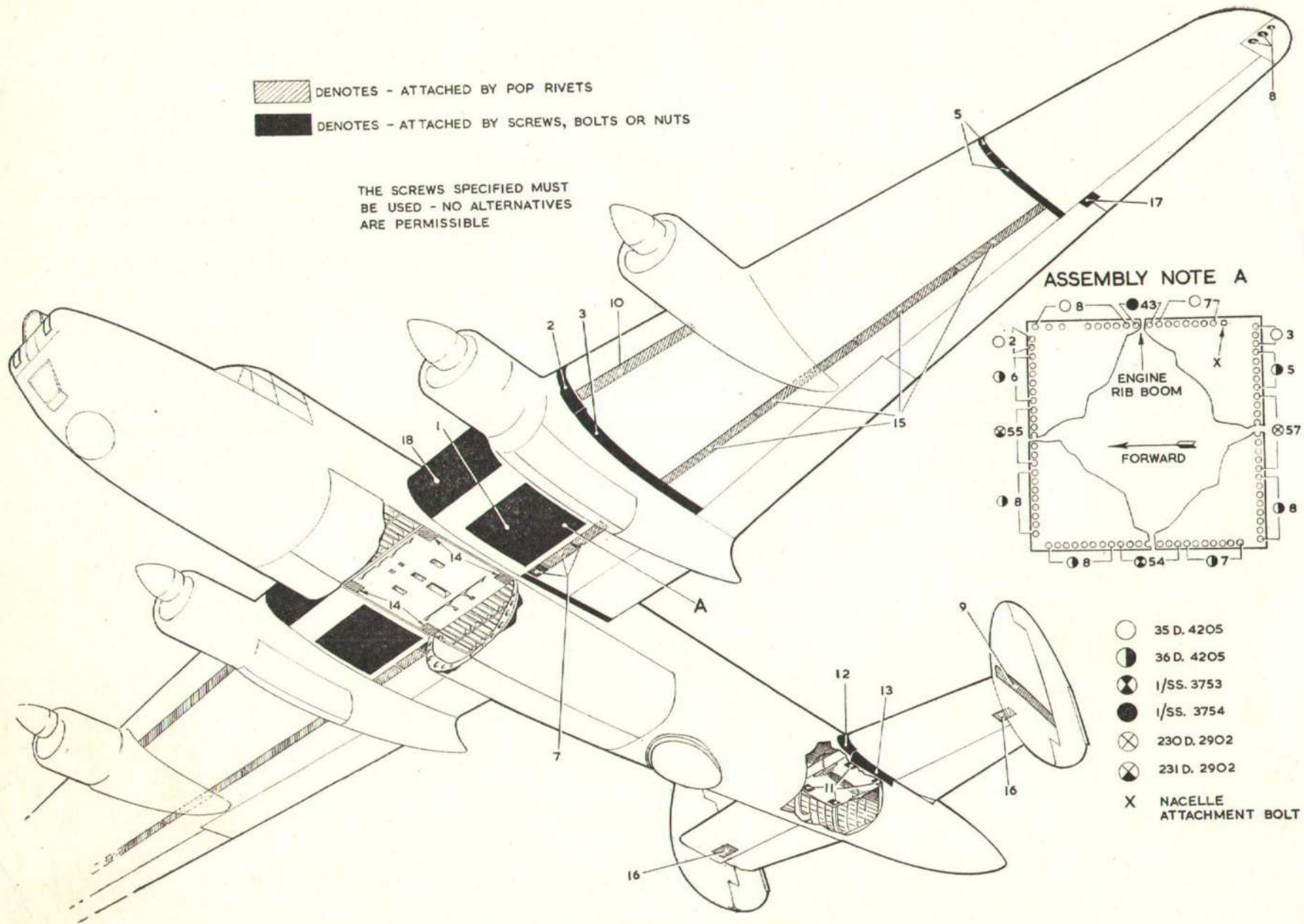

Fig. 7. Assembly panels—undersurfaces

RESTRICTED

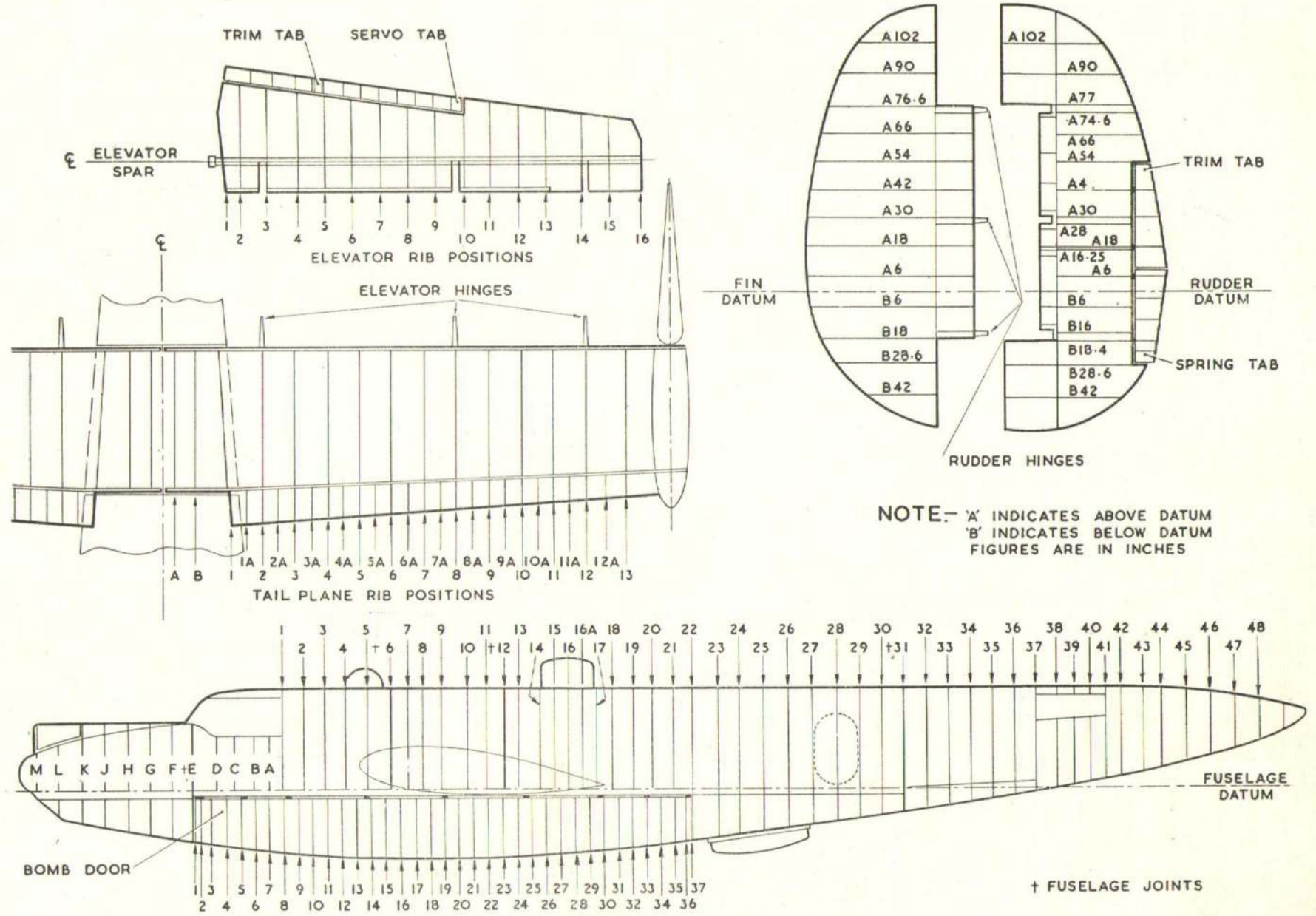

Fig. 8. Former and rib positions (I)

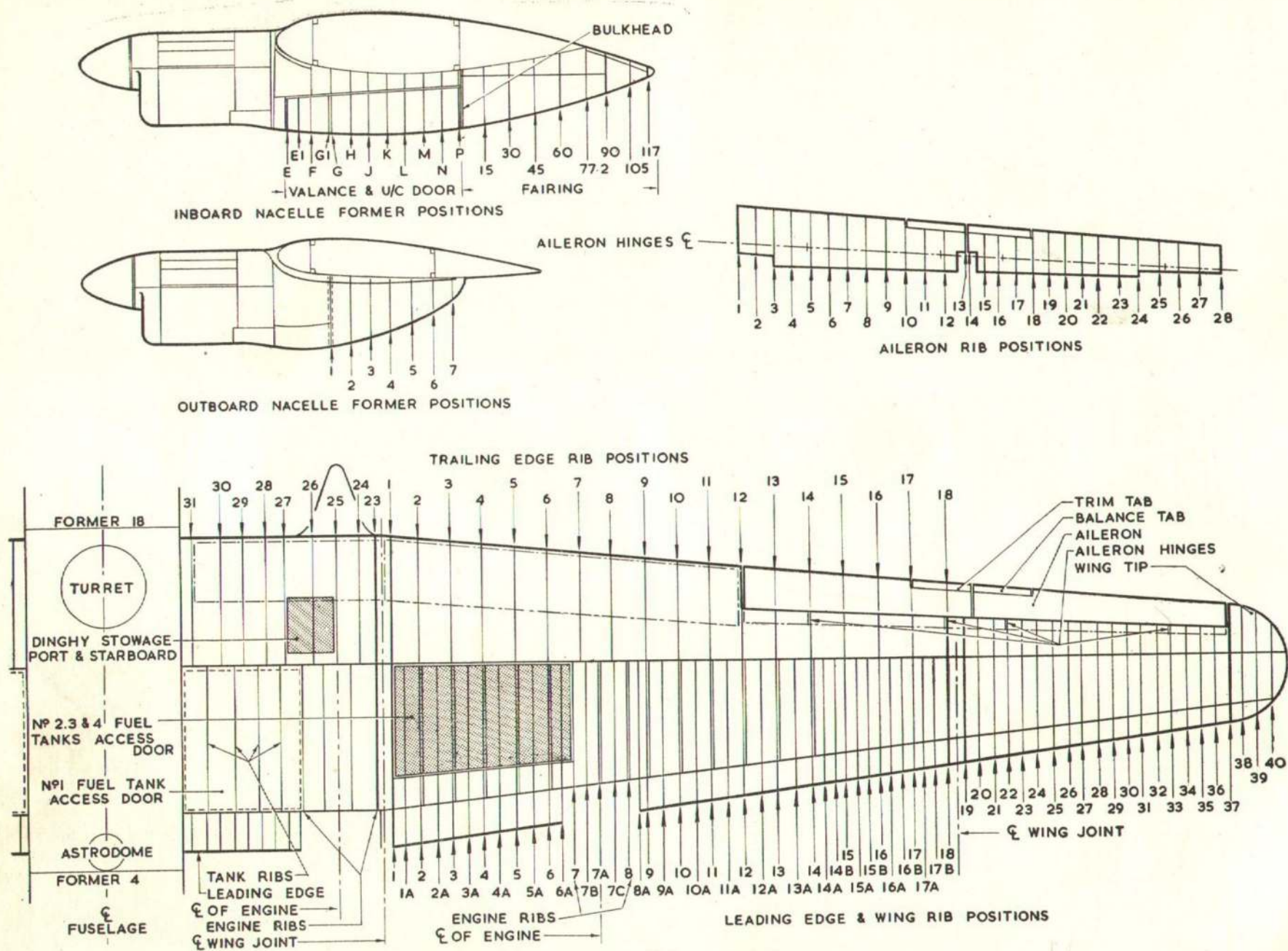

Fig. 9. Former and rib positions (2)

SEQUENCE OF ASSEMBLY

11. The following sequence of operations is recommended:-

- (1) Undercarriage to undercarriage beams and main plane centre sections (Sect.3, Chap.5).
- (2) Fuselage nose to front centre section (if not already assembled)-these are rarely separated (Sect.3, Chap.1).
- (3) Rear fuselage section (with retractable tail-wheel unit fitted) to rear centre section. The transparent rear fairing and the portion of the fuselage between formers 44 and 48 are sub-components of this section and the joints between them are manufacturing joints (Sect.3, Chap.1).
- (4) Rear fuselage assembly (3) to fuselage intermediate centre section (Sect.3, Chap.1).
- (5) Front fuselage assembly (2) to fuselage intermediate centre section (Sect.3, Chap.1).
- (6) Tail plane to fuselage (Sect.3, Chap.1).
- (7) Fins, rudders and elevators to tail plane (Sect.3, Chap.3).
- (8) Intermediate plane sections, without trailing edges, to centre plane (Sect.3, Chap.2).
- (9) Outer plane sections to intermediate plane sections.
- (10) Centre plane trailing edges, including flaps, to centre plane (Sect.3, Chap.2).
- (11) Intermediate plane trailing edges, including outboard flaps, to intermediate plane sections (Sect.3, Chap.2).

ASSEMBLING THE AIRCRAFT

- (12) Wing tip trailing edges to wing tips (Sect.3, Chap.2).
- (13) Ailerons to main plane (Sect.3, Chap.2).
- (14) Engine sub-frames, valances, undercarriage doors and nacelle fairings to main plane (Sect.4, Chap.1).
- (15) Firewalls to sub-frames (Sect.4, Chap.1).
- (16) Power plants to sub-frames (Sect.4, Chap.1).
- (17) Propellers to power plants (A.P.1538K, Vol.1).
- (18) Bomb doors to fuselage (Sect.3, Chap.1).

Assembly panels (fig.6 and 7)

12. Refer to the illustrations. Particulars of the methods employed for securing these panels are given in the relevant keys.

GENERAL SERVICING INFORMATION

FORMER AND RIB POSITIONS (fig.8 and 9)

13. The two illustrations show the former and rib positions of all major portions of the airframe. In addition, the positions of the transport joints in the fuselage and main planes are indicated.

ACCESS PANELS

14. The positions and purpose of the access panels on the aircraft are indicated in the illustrations. Mod.444 introduces a panel in the bomb compartment rear bulkhead to provide access to the ground supply socket connections.

JACKING AND SLINGING FOR SERVICING
(fig.2 and 4)

15. Equipment required to prepare the aircraft for servicing operations involving jacking or slinging, and the method of using it, is detailed in the following subparagraphs. Item numbers quoted refer to equipment listed in Table 1.

- (1) Jacking both main wheels; use two each of items 13, 14 and 15. Securely chock the tail wheel. Clearance required at the main wheels for removal is 5 in.
- (2) Jacking one main wheel; use one each of items 13, 14 and 15. Securely chock the tail wheel. The method for using the jack is shown in fig.3, and the instructions given on this illustration must be followed.

WARNING...

Failure to carry out the proper drill for raising one side of the aircraft only, can result in a serious accident.

- (3) Jacking all three wheels; use two each of items 13, 14 and 15 for the main wheels and 10, 11 and 19 for the tail wheels. It should be noted that the only steadying influence is the bases of the jacks, therefore, firm standing must be used under these circumstances.
- (4) Jacking in the rigging position; use two each of items 13, 14 and 15, one each of items 20 and 26, and one each of items 23 and 29. First chock the main wheels and, using a suitable crane and sling item 47, carefully lift the tail to enable trestle item 23, with item 29, to be placed under former 41. Place item 20, with item 26, under the nose at former E to steady the aircraft. Then raise the main-wheels 2 in. clear of the ground,

following up with beam item 26, on trestle item 20. The attitude of the aircraft can then be adjusted by differential alteration by the adjustment provided on items 20 and 23.

- (5) Hydraulic system operation testing; refer to Sect.3, Chap.6. The aircraft is to be jacked in accordance with para.15(4), substituting a No.17 universal jacking trestle (item 24) fitted with item 29 in place of items 23 and 29. Whilst there is no definite tendency for the aircraft to tip forward if the tail is raised high enough to place a No.17 trestle under former 41 (introduced from aft), the trestle item 20 with item 26 should be used when the aircraft tail is being raised above approximate rigging position. The beam on the trestle must be kept very near the skin at former E and gradually lowered as the tail is raised.

WARNING ...

Under no circumstances must the tail be lifted quickly, otherwise damage may result owing to inability to lower the nose steady-ing beam quickly enough. Before the scanner is lowered to the 'attack' position, the main-wheels must be raised 5 in. clear of the ground, then the screws on the No.17 trestle extended to raise the beam 12 in. from its initial bottom setting.

- (6) Main plane sections; the method of using the gantries employed, is indicated in the illustration.
- (7) Tail plane; it is essential, when one half of the tail plane is being removed, that the other half is supported by one each of item 21 with item 38, and the half to be removed properly slung, before any of the fuselage attachment or centre joint bolts are loosened or removed.

ITEM REFERENCES

REFER TO TABLE I IN TEXT

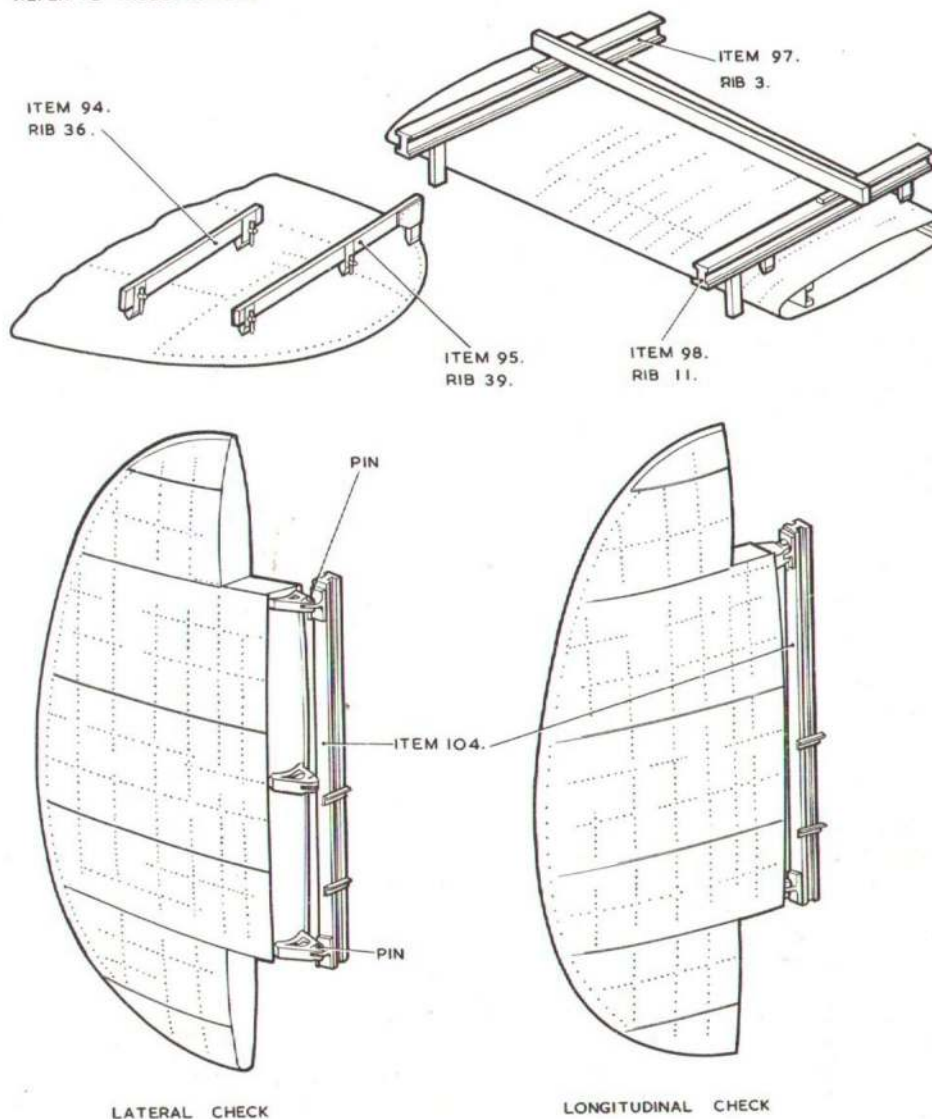

Fig.10. Wing tip, tail plane and fin checks

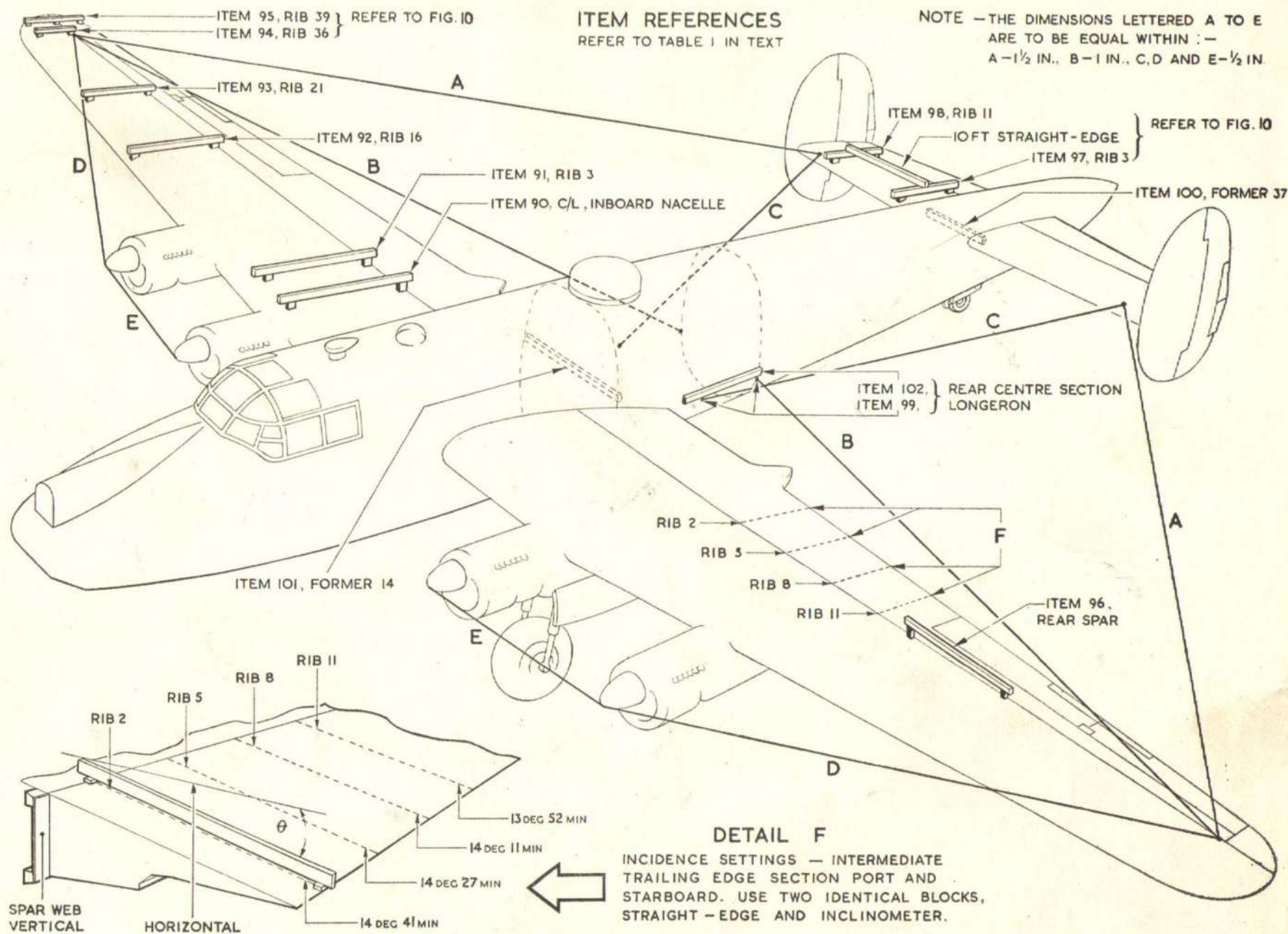

Fig. 11. Rigging position and main incidence checks

RESTRICTED

KEY TO FIG. 12

- | | |
|---|--------------------------------------|
| 1 VENT PIPE CONNECTION | 19 FUEL GAUGE TRANSMITTER |
| 2 UNDERCARRIAGE UP-LOCK CATCH PINS | 20 FIRE PROTECTION SYSTEM |
| 3 FIRE PROTECTION SYSTEM (fuel tanks) | 21 WING JOINT SHACKLE BOLTS |
| 4 INBOARD OIL TANK FILLER | 22 DINGHY COVER MANUAL RELEASE LEVER |
| 5 NO. 2 TANK FILLER | 23 DINGHY RELEASE CABLE PULLEY |
| 6 VENT PIPE CONNECTION | 24 WATER TANK FILLER |
| 7 VENT PIPE AND CABLE CLIPS | 25 DE-ICING PIPE CONNECTION |
| 8 VENT PIPE CONNECTION | 26 BELL CRANK BEARING |
| 9 TANK SUPPORT STRAPS | 27 TRIM CONTROL CABLES |
| 10 VENT PIPE CONNECTION | 28 TRIM CONTROL CABLES |
| 11 VENT PIPE CLIP | 29 TAPER BOLTS |
| 12 NO. 4 TANK FILLER | 30 FUEL GAUGE TRANSMITTER |
| 13 REBECCA AERIAL | 31 TANK FILLER DRAIN PIPE CONNECTION |
| 14 VENT PIPE AND FIRE PROTECTION SYSTEM | 32 NO. 1 TANK FILLER |
| 15 FLUX DETECTOR (port wing only) | 33 AUXILIARY FUEL PIPE CONNECTION |
| 16 FIRE DETECTOR SWITCHES | 34 AUXILIARY FUEL PIPE COUPLING |
| 17 FUEL GAUGE TRANSMITTER | 35 MAIN ENGINE FUEL FILTERS |
| 18 TANK ASSEMBLY PANEL LIFTING HANDLES | 36 OUTBOARD OIL TANK FILLER |

RESTRICTED

KEY TO FIG. 13

1 VIGATION LIGHT TERMINALS	20 OIL FILTER, TANK DRAIN VALVE AND FEATHERING WELL DRAIN COCK.	47 TRIM CONTROLS FAIRLEAD
2 BONDING CLIP AND CABLE FAIRLEAD.	21 ENGINE FUEL FILTER	48 HINGE BOLTS (INBOARD AILERONS)
3 BONDING CLIP AND CABLE FAIRLEAD.	22 OUTBOARD OIL TANK FILLER	49 NITROGEN SYSTEM VENT VALVES
4 BONDING CLIP AND CABLE FAIRLEAD.	23 WATER/METHANOL TANK FILTER	50 TORQUE TUBE ATTACHMENT BOLTS
5 BONDING CLIP, CABLE FAIRLEAD AND DE-ICING CONNECTION.	24 FUEL TANK REMOVAL PROCEDURE	51 HINGE BOLTS (OUTBOARD AILERONS)
6 BONDING CLIP, CABLE FAIRLEAD AND T.B.88	25 OIL FILTER AND FEATHERING WELL DRAIN COCK.	52 AILERON CONTROLS AND TORQUE TUBE
7 BONDING CLIP AND CABLE FAIRLEAD.	26 PICKETING ATTACHMENT	53 AILERON CONTROLS
8 BONDING CLIP, CABLE FAIRLEAD AND DE-ICING CONNECTION	27 ENGINE FUEL FILTER	54 T.B.325
9 BONDING CLIP AND CABLE FAIRLEAD.	28 VISION DE-ICING FLUID TANK DRAIN.	55 HINGE BOLTS (OUTBOARD AILERONS)
10 BONDING CLIP, CABLE FAIRLEAD AND DE-ICING CONNECTION	29 JACKING POINT	56 DETACHABLE WING TIP TRAILING EDGE ATTACHMENT
11 BONDING CLIP AND CABLE FAIRLEAD.	30 MASTER ENGINE FUEL COCK INDICATOR	57 STATIC VENT DRAINS
12 BONDING CLIP AND CABLE FAIRLEAD.	31 FUEL GAUGE DRAIN SUMP	58 RUDDER CONTROLS AND FIN DE-ICING PIPE
13 BONDING CLIP AND CABLE FAIRLEAD.	32 NO.1 FUEL PUMP	59 TRIM CABLE FAIRLEAD
14 BONDING CLIP, CABLE CONNECTION AND T.B. 51, 52 AND 59.	33 NO.1 TANK DRAIN COCK	60 DE-ICING PIPE CONNECTIONS AND AERIAL TENSIONING DEVICE
15 PICKETING ATTACHMENT	34 DE-ICING PIPE AND AILERON CONTROL CONNECTION	61 RUDDER LOCKING SYSTEM BELL-CRANK
16 NITROGEN SYSTEM REDUCING VALVES.	35 FUEL SYSTEM MANIFOLD, NO.1 FUEL COCK AND MAIN FUEL DRAIN VALVE.	62 RUDDER LOCKING BOLT OPERATING LEVER
17 BONDING CLIP, CABLE FAIRLEAD AND DE-ICING CONNECTION	36 DE-ICING SYSTEM PUMP AND FILTER	63 RUDDER HINGE BOLTS
18 BONDING CLIP AND CABLE FAIRLEAD.	37 OIL TANK DRAIN VALVE	64 RUDDER SPRING TAB CONTROL LINKAGE
19 NO.4 TANK DRAIN COCK.	38 NO.2 TANK DRAIN COCK	65 ELEVATOR HINGE BOLT
20 BONDING CLIP, CABLE FAIRLEAD AND DE-ICING CONNECTION	39 AILERON CONTROL RODS	66 HINGE BOLTS
21 BONDING CLIP, CABLE FAIRLEAD, FIRE PROTECTION AND PRIMING STEM VENT PIPES	40 NO.2 FUEL PUMP	67 ELEVATOR TRIM OPERATING JACK
22 BONDING FAIRLEAD AND DE-ICING CONNECTIONS	41 FUEL TANK REMOVAL PROCEDURE	68 TORQUE TUBE ATTACHMENT TAPER BOLTS
	42 NO.3 FUEL COCK	69 DE-ICING CONNECTION
	43 NO.3 FUEL PUMP	70 RUDDER CONTROL BELLCRANK SHAFT BEARING
	44 FIRE PROTECTION SYSTEM	71 RUDDER CONTROLS
	45 WATER/METHANOL FLUID PUMPS	
	46 WATER/METHANOL FLUID FILLER	

RESTRICTED

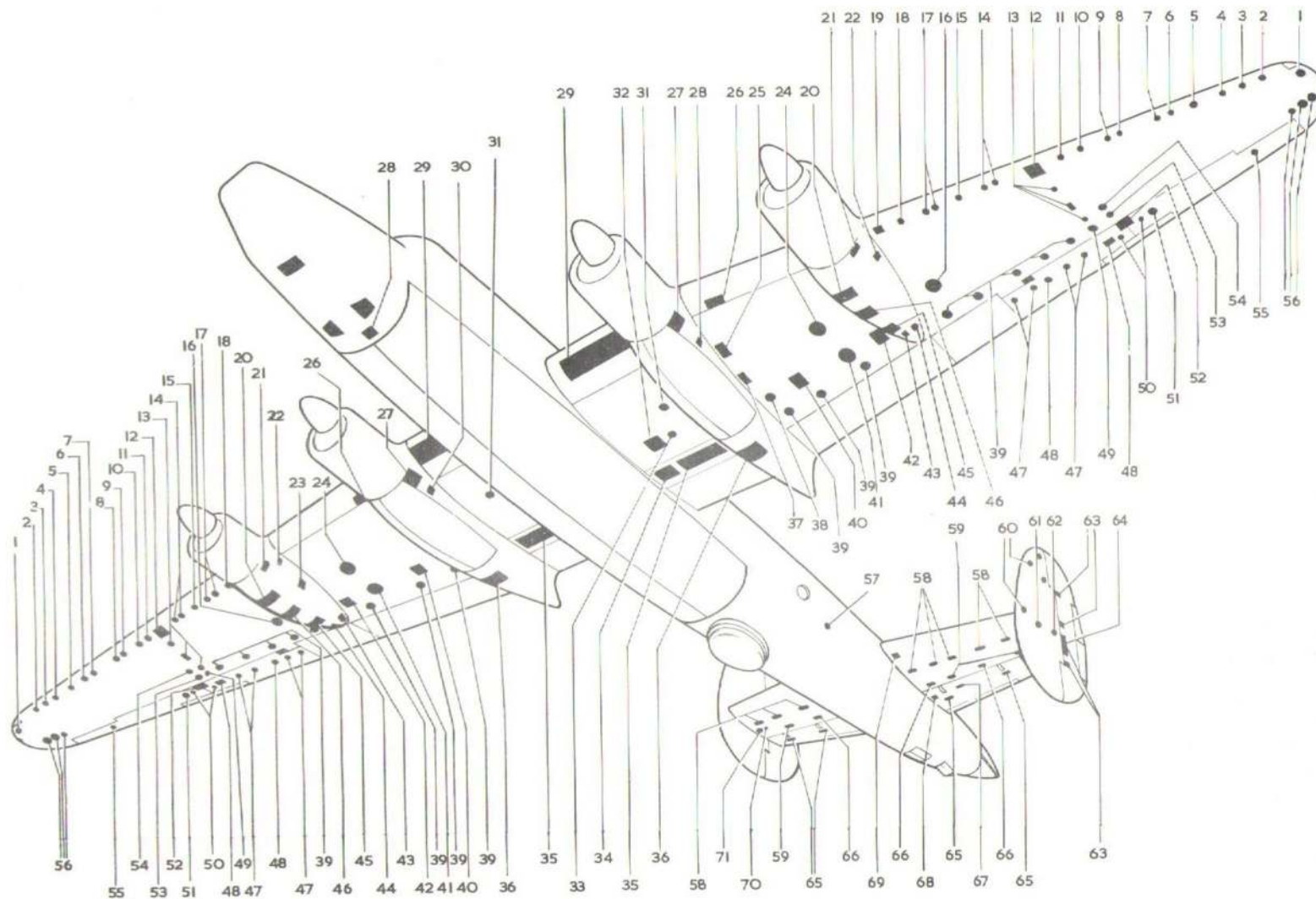

Fig.13. Access panels - undersurface

RESTRICTED

RIGGING OF FIXED SURFACES

16. The main plane and tail plane are fixed cantilever structures and their attitude is determined during assembly of the component sections. No adjustments can be made to the attitude of the tail plane or fins, but the incidence of the intermediate and outer sections of the main plane can be predetermined during assembly (Sect.3, Chap.4). The normal rigging operations are those of checking the incidence and dihedral of the main and tail planes and the attitude of the fins.

Rigging position (fig.11)

17. Jack and trestle the aircraft (para.15, sub-para.4) and level the aircraft as follows:-

- (1) Level longitudinally by fitting two pegs, Table 1, item 99, into the two slinging points at the rear end of one of the rear centre section longerons (at floor level). Place a straight edge, item 102, across the pegs and check with a spirit level.
- (2) Level laterally by placing the straight edges, item 100 and 101 across the datum blocks attached to formers 37 and 14 respectively, inside the fuselage, and check each with a spirit level.

Main plane (fig.10 and 11)

18. The normal incidence of the main plane is 4 deg. \pm 15 min., but the following points should be noted:-

- (1) The incidence of the port wing must be increased by 3 min. and that of the starboard wing decreased by 3 min. from the nominal setting to give a differential setting of 6 min. when initially rigging the main plane or on replacement.

NOTE . . .

This initial differential setting may be modified by any final adjustments made after flight testing (Sect.3, Chap.4).

- (2) This incidence variation of the complete span from tip to tip may not exceed 0 deg. 20 min.

- (3) The incidence variation in the centre section may not exceed 0 deg. 4 min. from end to end.

- (4) The variation in each intermediate section may not exceed 0 deg. 3 min.

KEY TO FIG.14 (WEATHERPROOFING)

- (1) Fuselage joints are to be made with Bostik jointing compound, Ref.No.33H/185 both inside and outside line of bolts before bolting up. Cover joints with 3 in. strip (serrated-edge fabric).
- (2) Joints between centre section leading and trailing edge and fuselage are to be made with Bostik Ref.No.33H/185. Apply 4 in. fabric strip (detail F).
- (3) Apply Bostik, Ref.No.33H/185, between all aerial lead-in insulators and fuselage skin.
- (4) 3 in. fabric strip around edge of dinghy stowage covers.
- (5) Use Bostik Ref.No.33H/185, around outside of clamping ring and insulator.
- (6) Apply Bostik Ref.No.33H/185, to ice guard of sonobuoy aerial.
- (7) Use Bostik, Ref.No.33H/185, between edges of detachable panels, fairings and tail plane or fuselage skin. Apply 3 in. fabric strip in angle, 4 in. strip at edges of fairing and a madapollam patch, D.T.D.343A (Ref.No.32B/556), opposite leading edge (Detail A and B).
- (8) 1½ in. strip at edges and 3 in. strip over expansion gap (wing joint assembly panels)
- (9) 1½ in. strip over wing tip detachable trailing edge.
- (10) 1½ in. strip around transparent panel over taxiing lamps.
- (11) 2 in. strip along edge of wing joint panels.
- (12) 5 in. strip around No.4 tank filler assembly and vent connection access panel.
- (13) 5 in. strip along trailing edge joint (detail E) and tank assembly panel.
- (14) 5 in. strip, cut to shape, at mounting flange of aerial masts (detail D).
- (15) When fitting gun turret, use Celloseal chromated sealing compound Ref.No.33H/113 between turret base and dished mounting.
- (16) 1¼ in. strip around bombaimer's window.

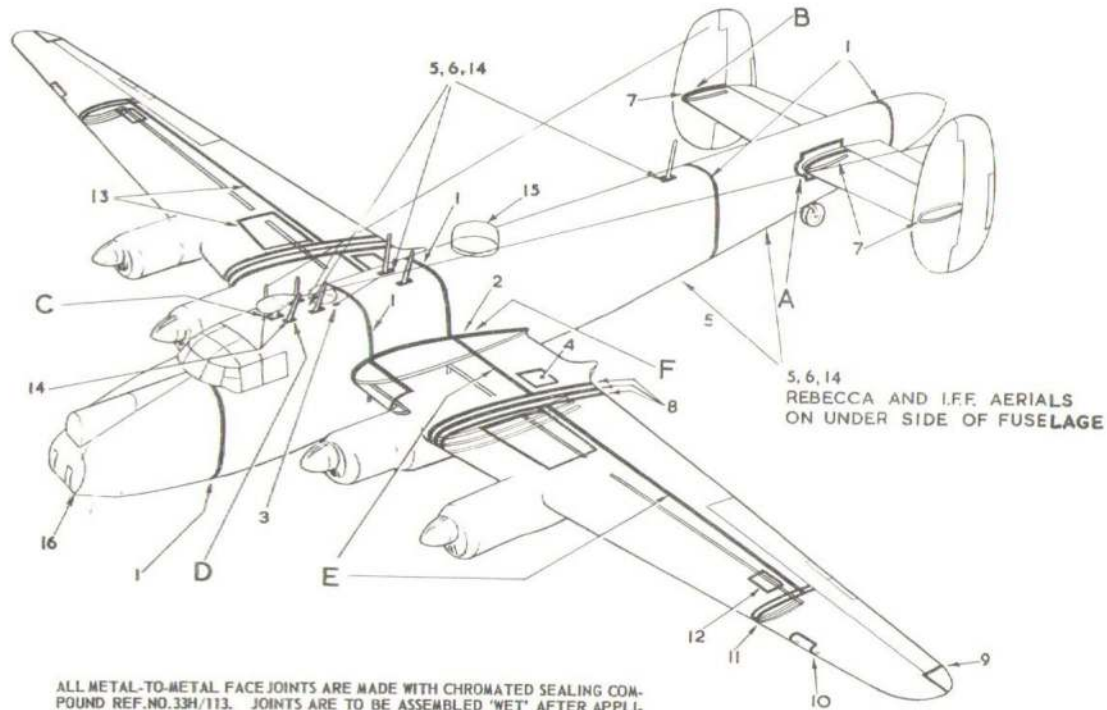

ALL METAL-TO-METAL FACE JOINTS ARE MADE WITH CHROMATED SEALING COMPOUND REF.NO.33H/113. JOINTS ARE TO BE ASSEMBLED "WET" AFTER APPLICATION OF SUFFICIENT SEALING COMPOUND TO PRODUCE A FILLET AT EACH JOINT.

IN ALL FUSELAGE TRANSPORT JOINTS A BEAD OF BOSTIK (REF.NO.33H/185) IS TO BE INSERTED BEFORE BOLTING UP.

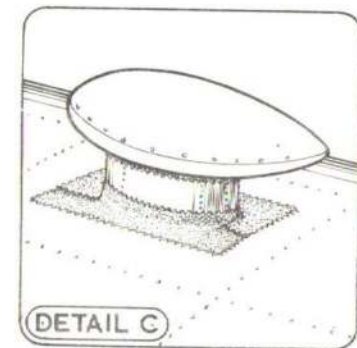
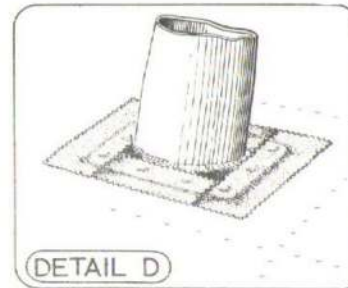
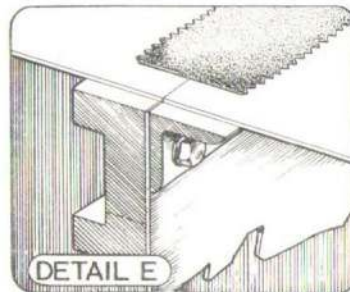
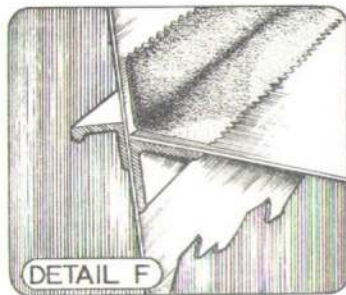
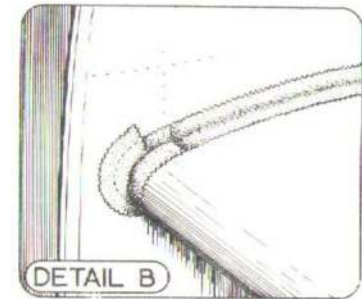
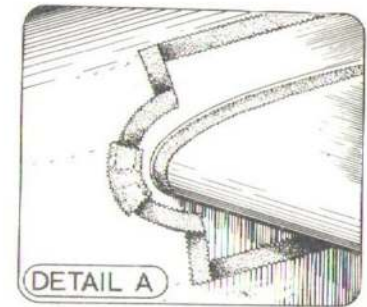

Fig.14. Weatherproofing
RESTRICTED

- (5) The variation in each outer section may not exceed 0 deg. 5 min.

Check the incidence of the main plane at the centre-line of the inboard engine and at ribs 3, 16, 21, 36 and 39, as shown in the illustrations on which the Table 1 item numbers of the gauge to be used are indicated. Check also the main plane dihedral as shown in the illustration.

NOTE...

When using an inclinometer, readings should be 0 deg. \pm 15 min.

Tail plane (fig.10 and 11)

19. The tail plane incidence is 1 deg. 15 min. \pm 15 min. and is checked as shown in either illustration (inclinometer readings should be 0 deg. \pm 15 min.). The horizontal level is checked by using a spirit level. A tolerance of \pm 15 min. is permissible.

Fins (fig.10)

20. The hinge line should be vertical in the lateral plane, and have a 1 deg. 15 min. \pm 15 min. forward inclination from vertical in the fore and aft plane. These

checks are made as indicated in the illustration, using a spirit level and inclinometer respectively on the angle brackets provided on the gauge.

SETTING THE FLYING CONTROLS

21. Refer to Sect.3, Chap.4.

WEATHERPROOFING (fig.14)

22. Sealing of joints in the aircraft is accomplished by fabric strips of varying widths, attached with Titanine adhesive F.1. To prepare the adhesive mix 10

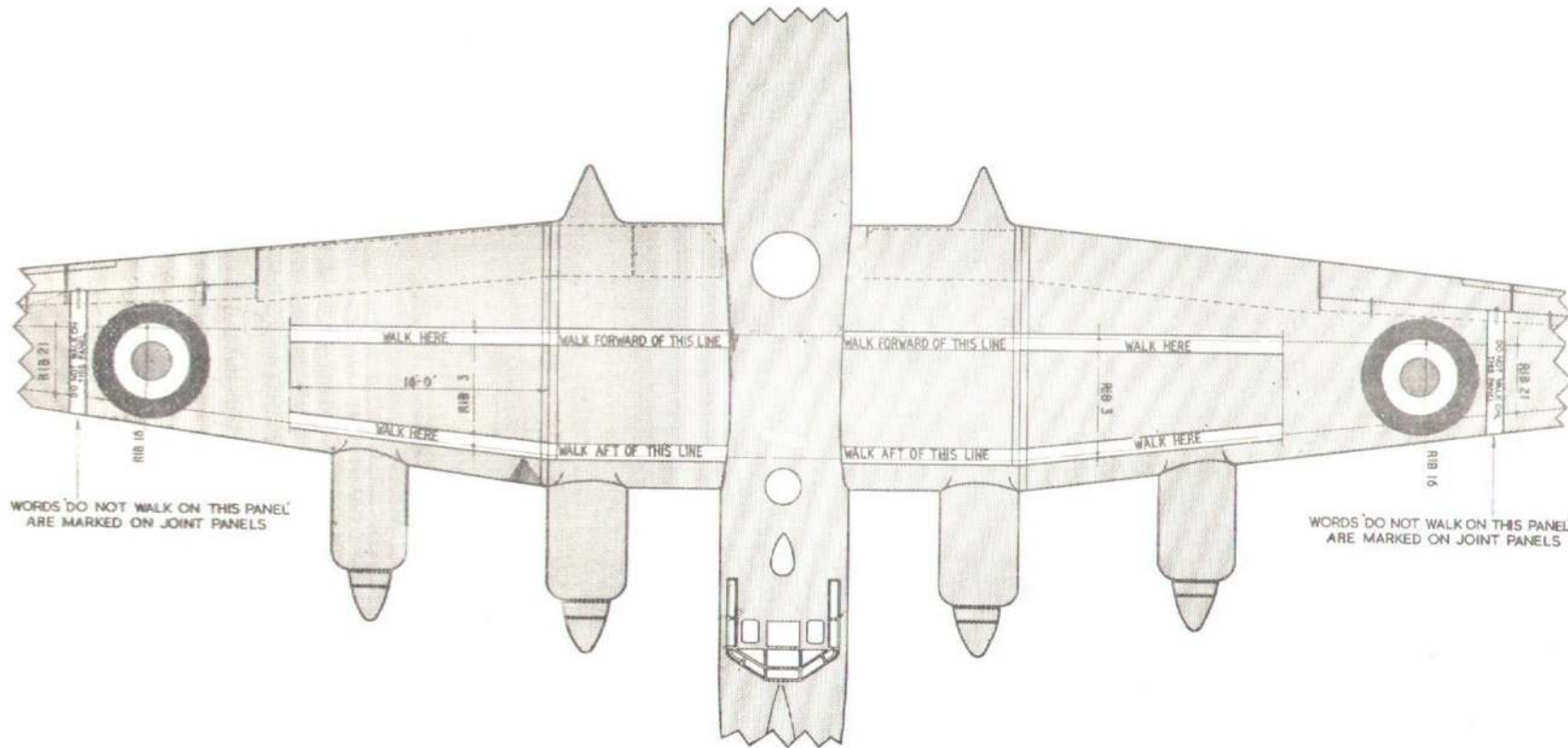

Fig.15. Walkways.

RESTRICTED

parts by volume of adhesive F.1 (Ref.No. 33H/19), with an approximate equal volume of thinners F.T.1. (Ref.No.33H/21). Add one part by volume of catalyst F.C.1. (Ref.No.33H/20), and mix thoroughly. The adhesive has an approximate "pot life" of 4 hours. Before application of fabric, the aircraft finish should be removed down to the primer.

23. To apply fabric to aircraft joint, proceed as follows:-

- (1) Apply one brushcoat of adhesive (as previously prepared in para.22) on area to be covered with fabric. Allow 30 minutes drying.
- (2) Apply a second coat of adhesive

and allow 10 minutes drying.

- (3) Lay fabric over the prepared area, stretching it as much as possible, at the same time removing creases and wrinkles.

NOTE...

It is essential that the fabric be applied correctly at this stage, corrections at a later stage are very difficult, as the adhesive when dry does not soften back with solvent.

- (4) Brush one coat of adhesive through the fabric, and allow 20 minutes drying. Use a wooden scraper to pull out any imperfections and to

press adhesive through the weave.

- (5) Allow 24 hours to dry before applying the appropriate finishing scheme.
- (6) All tooling and routing holes are to be sealed with doped canvas patches to prevent ingress of water.

NOTE...

To achieve a better finish, the fabric may be smoothed out by lightly dry scuffing with 320 grade abrasive paper.

WALKWAYS

24. The permitted walkways and restricted areas are shown in fig.15.



This file was downloaded
from the RTFM Library.

Link: www.scottbouch.com/rtfm

Please see site for usage terms,
and more aircraft documents.

