

Chapter 5 CHANGE OF ROLE

(This chapter supersedes that issued with A.L.83 and 90)

POWER PLANT TRANSPORTATION

	Para
Introduction	1
Carrier and transport cradle	2
Loading operations	
Attaching a power plant to the carrier	3
Attaching the carrier to the aircraft	4
Removal operations	5

Introduction

1. Mod. 316 (S.O.O.) introduces a carrier which can be attached to the aircraft bomb release units after being loaded with a Griffon Mk. 57 power plant complete, less propeller. The carrier is normally always attached to a wheeled transport cradle of which the wheels are detachable and can be stowed when the complete loaded assembly is attached to the aircraft. Stops are fitted to prevent the bomb doors being closed more than by the amount permissible when the assembly is carried. The following instructions are complimentary to those contained in the information leaflet for Mod. 316.

CARRIER AND TRANSPORT CRADLE

2. These are illustrated in fig. 1. The carrier is the upper and rear part of the assembly and is bounded at the rear by four attachment forks. At the front end it is bounded by the upper half of a collar which is secured to a lower half-collar by two quick-release pins. The upper pair of the four forks attach directly to the upper lugs of a Griffon 57 power plant whilst the lower pair are attached to the transport cradle as well as to the power plant. The carrier, which carries the whole weight of the power plant when attached to the aircraft, is suspended from bomb slips No. 13, 17, 19 and 23 by

LIST OF CONTENTS

	Para.
Servicing	6
MAIN WHEEL TRANSPORTATION	
Introduction	7
Carrier	8
Loading operations	
Attaching a wheel to a carrier	9

LIST OF ILLUSTRATIONS

	Fig.
Power plant transport carrier	1
Spare wheel transport carrier	2
Mounting of lifeboat carrier	3
E.M. release unit assembly	4

POWER PLANT TRANSPORTATION

the four hooks shown, being steadied by the crutching pads forward and the steady screws aft, all of which are illustrated.

LOADING OPERATIONS

Attaching a power plant to the carrier

3. Assuming the assembly erected as illustrated, but less a power plant, proceed as follows:—

- (1) Part the front collar of the carrier and cradle assembly by removing the two quick-release pins (*detail top left, fig. 1*).
- (2) Lift the front end of the carrier up and over to the rear until the rear steady screw brackets are on the ground.
- (3) Remove the two top power plant attachment point assemblies as detailed below:—
 - (a) Remove nut (7) washer and cup washer (6) and bolt (5).
 - (b) Re-assemble these items reversed, i.e., items (6) and (7) at the side where (5) was previously. Tighten (7) and tap (5) with a light hammer until the taper plug (4) is loose. Finally remove (4), (5), (6) and (7), then split bush (3).

	Para.
Attaching a loaded carrier to the aircraft	10
Removal operations	11
Servicing	12

LIFEBOAT TRANSPORTATION

Introduction	13
Attachment of pylon to aircraft	14

SERVICING

Release unit testing	16
-----------------------------	----

- (4) Similarly, remove items 5 to 9 of the lower power plant attachment point assemblies, initially reversing items (7), (8) and (9) and proceeding as in (b) above—tighten (9) and tapping (7), and finally remove (6) and (5). Leave items (3) joining (1) and (2).
- (5) Using a sling, Stores Ref. 4G/4170, lift the power plant from its transport stand, lower it into the cradle and locate the power plant lower rear lugs in the lower attachment points and fit items (5) to (9). Allow the power plant propeller shaft to rest in the lower half of the front collar.
- (6) Remove the sling, swing the carrier over the power plant and join the two halves of the front collar with the two quick release pins.
- (7) Refit the upper power plant attachment point assemblies items (3) to (7) and then lock all four attachment assembly nuts with split pins.
- (8) Do not adjust the wing nut under the front bracket except to ensure that all the thread of the screwed rod is above the nut as shown in the main portion of the illustration.

(A.L.96, May 57)

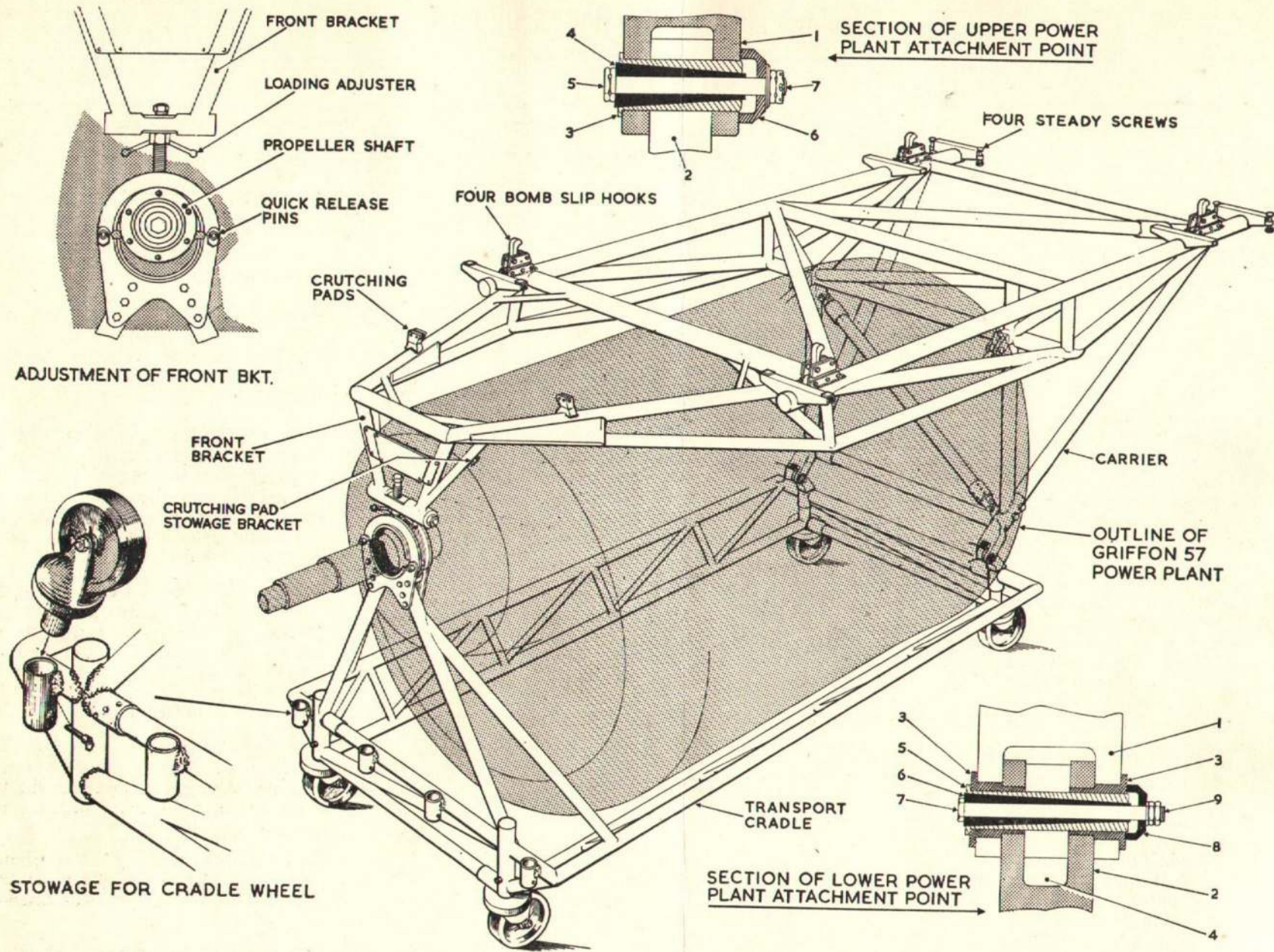

Fig. 1. Power plant transport carrier

RESTRICTED

Note . . .

Read the label on the front bracket. The reason for the instructions on it and for those in this sub para. is that the power plant assembly incorporates rubber anti-vibration devices which must not be negatively loaded for any length of time. This entails the wing nut being screwed to the top of the thread when the loaded power plant carrier is attached to the aircraft. However, when it is not attached, the necessary stresses cannot be borne by the carrier and the opposite instruction is operative, but the following warning is then applicable.

WARNING . . .

Do not leave a loaded carrier assembly standing about at all. It is most essential to attach a carrier to an aircraft immediately after loading it with a power plant and to carry out the instructions on the label (NOTE above) to produce a down thrust on the propeller shaft. No time limit under these latter conditions is applicable, since the engine supports of the power plant are then normally loaded.

Attaching the carrier to the aircraft

4. To attach the loaded carrier to the aircraft proceed as follows:—

- (1) Open the bomb doors.
- (2) Wheel the loaded carrier and cradle, as illustrated in fig. 1, from the front of the aircraft to under the bomb compartment and position the four attachment hooks under the bomb station 13, 17, 19 and 23 with the propeller shaft of the engine facing forward.
- (3) Remove the two crutching pads which

Introduction

7. Mod. 317 (S.O.O.) introduces adapters to enable main wheels to be suspended from those bomb release units which are on the centre line of the aircraft. Information regarding the fitment of the wheel to the

are secured to stowage brackets (*illustrated*) at the front end of the carrier and, using the attachment bolts, fit them to the 12th and 13th holes outboard of the aircraft centre line in the floor joint under the front spar. They should be fitted so that the offset of each locates the pad surface outboard relative to the attachment bolts. Stow the four bolts taken from the floor joint in the holes in the pad stowage brackets.

Note . . .

The centre line of the aircraft is located between two bolt holes in the floor joint between which the interval is less than that between all the other bolts.

- (4) Fit four 2,000 lb. Mk. 2 bomb winches, Stores Ref. 4G/2331, to the bomb stations to be used (*sub-para.* 2) to hoist the loaded carrier into position until the carrier is correctly suspended from the four bomb release units, checking that the releases are correctly cocked and that all is safe in accordance with current authorised procedure before removing the winches.
- (5) Adjust the rear crutching screws in accordance with normal crutching procedure.
- (6) Carry out the instructions borne on the label attached to the front bracket of the carrier (the appearance of the front collar, after this course has been taken, is to resemble that of the associated inset in the illustration). Refer also to para. 3 (8).
- (7) Release the carrier transport cradle wheels by removing the securing quick-release pins and stow these in the four

MAIN WHEEL TRANSPORTATION

carrier and the carrier to the aircraft is contained in the information leaflet to Mod. 317. The following information is supplementary to the above.

sockets provided at the front of the cradle, securing them with quick-release pins.

- (8) Fit the stop blocks provided to the bomb door jacks. They must be fitted with the slotted end downwards. Then close the doors, using the handpump.

Note . . .

Whilst the doors are closing (they can only partially close with the stops fitted) check that none of the stop blocks foul any locking wire on the jack glands. If necessary, fit new wire in such a way as to prevent any chafing against the stops when the doors are closing or fully closed up to limit set by stops.

- (9) It should be noted that the loaded carrier weighs 4,025 lb. and that its moment about the aircraft C of G is +16,781 lb. ft.

REMOVAL OPERATIONS

5. In each case these are the logical reversal of the preceding two paragraphs and no difficulty should be encountered in carrying them out.

Note . . .

Read the label at the front of the carrier first.

SERVICING

6. Storage and periodical servicing of the complete carrier should be in accordance with the practice current for armament equipment of similar nature. Particular attention should be paid to careful checking of the assembly after use to ensure that all parts are available, and correctly fitted or stowed for future use.

CARRIER (fig. 2)

8. This consists of two parts between which the wheel is clamped with the aid of a tie-bolt and wing nut. One of these parts is the upper half when the wheel is loaded on the aircraft in a horizontal attitude and is fitted

NOTE IN EXPLODED VIEW BELOW THE CENTRAL TIE ROD IS SHOWN BROKEN FOR CONVENIENCE IN ILLUSTRATING UPPER AND LOWER PARTS OF CARRIER.

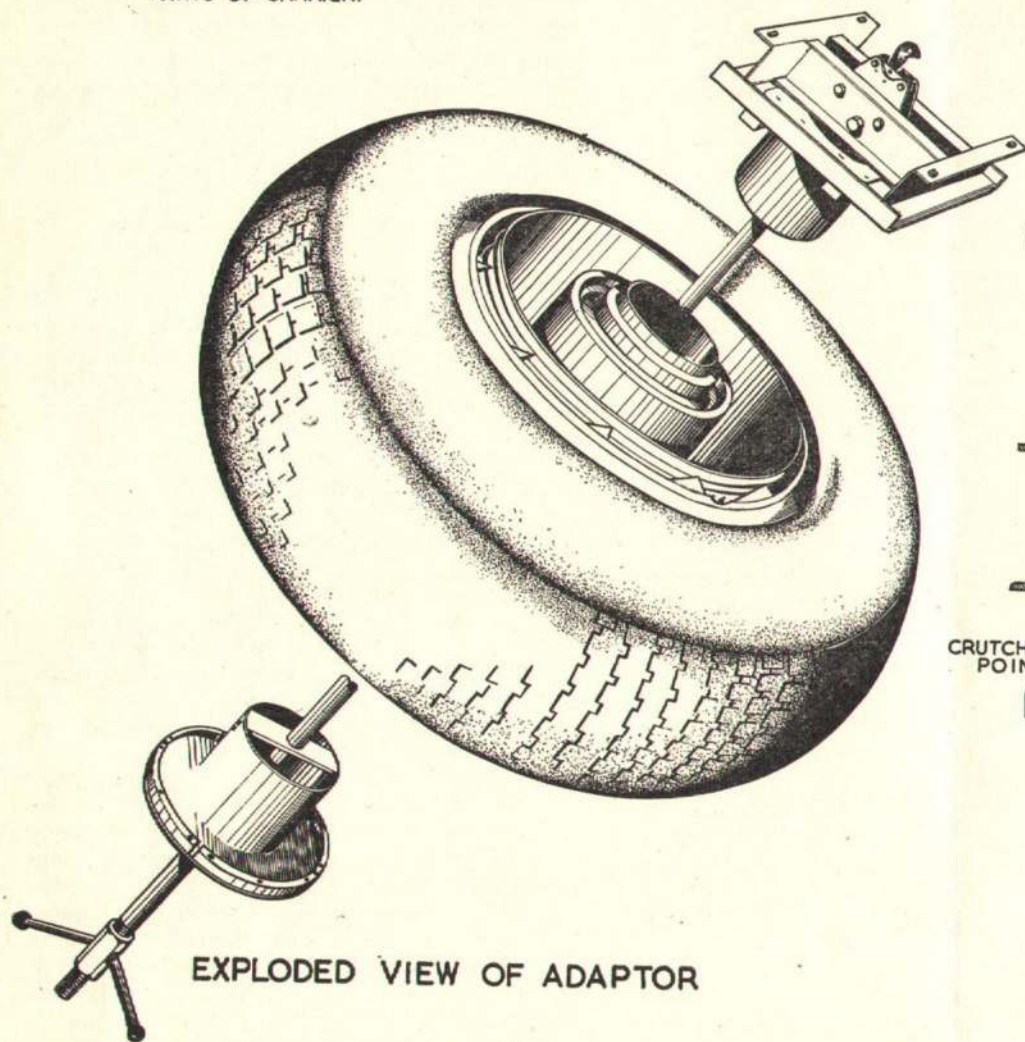

EXPLODED VIEW OF ADAPTOR

USE NO 4 ADAPTOR
TYPE A.V.122

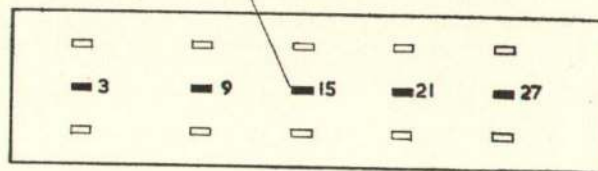
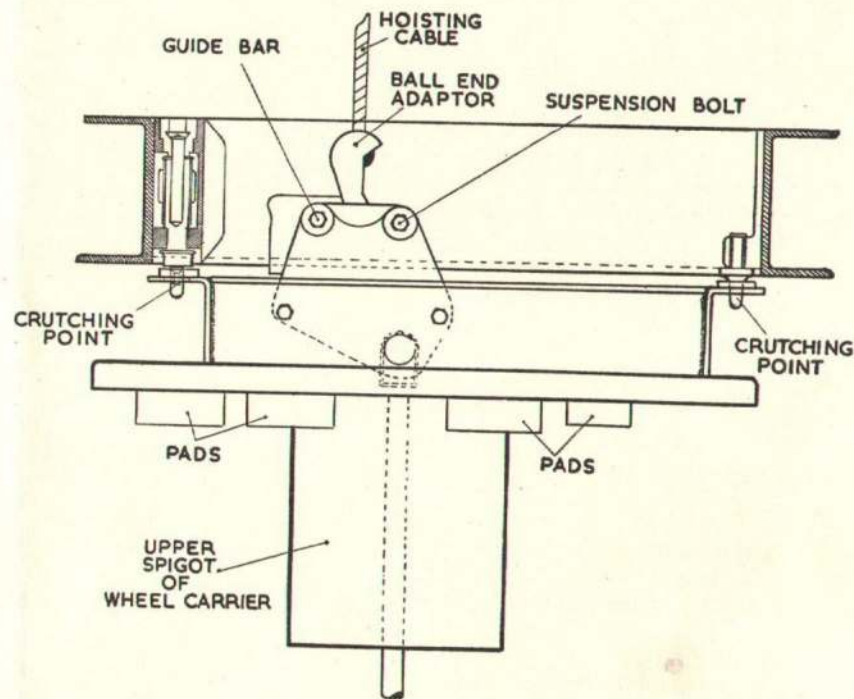

DIAGRAM OF FITTING POINTS IN BOMB BAY



INSTALLATION DIAGRAM

Fig. 2. Spare wheel transport carrier

RESTRICTED

with a bushed bolt retaining a distance piece between two hoisting plates. This latter assembly engages with any bomb release unit on the centre line of the bomb compartment, except No. 15, the heavy unit. In this latter case, a No. 4 adapter, type AV.122, must be used to enable a carrier to be fitted.

LOADING OPERATIONS

Attaching a wheel to a carrier (fig. 2)

9. Assuming the carrier is assembled less a wheel, proceed as follows:—

- (1) Remove the wing nut from the carrier tie rod, first removing the split cotter pin if one is fitted.
- (2) Remove the lower fitting (circular) from the tie rod.
- (3) Remove the brake unit (refer to Sect. 3, Chap. 5, para. 3) from the wheel, stow the unit in the aircraft and secure it in accordance with the current regulations.
- (4) Thread the tie rod of the carrier and the

INTRODUCTION

13. Mod.177 (S.O.O.) introduces a removable transport pylon suspended from the slip hooks in the bomb gear housings at bomb stations 9, 13, 15 and 17. The procedure for attaching the pylon to the bomb compartment roof is contained in the following paragraphs and illustrations.

ATTACHMENT OF PYLON TO AIRCRAFT (fig. 3)

14. Proceed as follows:—

- (1) Open the bomb doors and remove the detachable panels between ribs 16 and 18 retaining all parts for future use (refer to Sect. 3, Chap. 1, para. 22).
- (2) Suspend the eyebolts from the rear strut assembly on the slip hooks in the bomb gear housings at bomb stations 13 and 17, using the relevant pins, washers and split pins. (Detail A).
- (3) Secure the connecting block at bomb station 15 with the relevant bolt, washer and self-locking nut. (Detail B).
- (4) Offer up the rear strut assembly and secure the port and starboard struts to the eyebolts suspended at bomb stations

spigot of the upper fitting into the wheel hub, refit the lower fitting of the carrier on the tie rod and the associated spigot into the wheel hub so that the threaded end of the tie rod protrudes from the lower fitting central boss.

- (5) Refit the wing nut and fit a new split cotter pin, Stores Ref. 28P/12463.

Attaching a loaded carrier to the aircraft

10. Proceed as follows:—

- (1) Open the bomb doors and select the bomb station or stations to be utilised from No. 3, 9, 15, 21 and 27. These are the centre longitudinal row of bomb stations—No. 15 the centre one, must be fitted with a No. 4 adapter in order to accommodate the attachment hook of the carrier.
- (2) Fit a 2,000 lb. bomb winch, Stores Ref. 4G/2331, to the selected station, lower the winch cable and fit the end ball to the ball socket of the carrier.

LIFEBOAT TRANSPORTATION

13 and 17 with washer, nut and split pin. (Detail A). Secure the cross-stays to the connecting block and screw the turnbuckle of the tie-rod on to the threaded portion of the connecting block.

- (5) Position the slip winch and message tube and secure in position with the clips at the upper and lower ends. (Detail C and E).
- (6) Insert the crutching unit on the slip hook at bomb station 9. Adjust the eyebolt in the forward stay until the pin can be inserted at the release unit housing and the split pin fitted. (Fig. D).
- (7) Adjust the tie-rod and the forward stay to obtain the dimensions given in detail E. Tighten the lock-nuts on the eyebolt and turnbuckle and lock with wire. Tighten the crutching unit and lock the handwheel with wire.
- (8) Secure the bracket for manual release to the existing stiffening plate aft of floor beam 9 with the relevant screws.
- (9) Uncoil the plug lead with ident.

- (3) Hoist the carrier, guiding the roller between the forward ends of the hoisting plates into the locating guide of the bomb release unit until the unit is cocked, in accordance with normal bombing-up procedure.
- (4) Remove the winch and close the bomb doors.
- (5) It should be noted that the loaded carrier weighs 832 lb. plus 110 lb. for the associated brake drum (para. 9, sub-para. 3); also that the moment arms at the various stations are as stated below fig. 2 of Chapter 3 of this Section.

REMOVAL OPERATIONS

11. In each case these are the logical reversal of the preceding two paragraphs and no difficulty should be experienced in carrying them out.

SERVICING

12. The recommendations made in para. 6 also apply to spare wheel carriers.

B.S.9 and tape the lead to the forward stay as required. Pass the plug through the hole in the bomb gear housing side plate at bomb station 9 and plug into the socket. Leads with ident. B.S.13 are to be plugged into the socket at bomb station 13 and leads with ident. B.S.15 into the socket at bomb station 15. Connect socket leads with ident. "Rel. Skt." to the two-pin plug at bomb station 15. Connect the positive lead at the bottom end of ident. B.S.15 to the E.M. release unit and the earthing tag to the bolt on the socket mounting bracket at the E.M. release unit housing. Plug the leads with ident. B.S.17 into the socket at bomb station 17. Connect the positive lead from the socket (Stores Ref. 5C/455) to the E.M. release unit and the earthing tag to the socket mounting bracket.

15. Full instructions for loading and unloading the lifeboat and associated gear are contained in A.P.4366A, Vol. 1, Sect. 1, and A.P.4046A, Vol. 1.

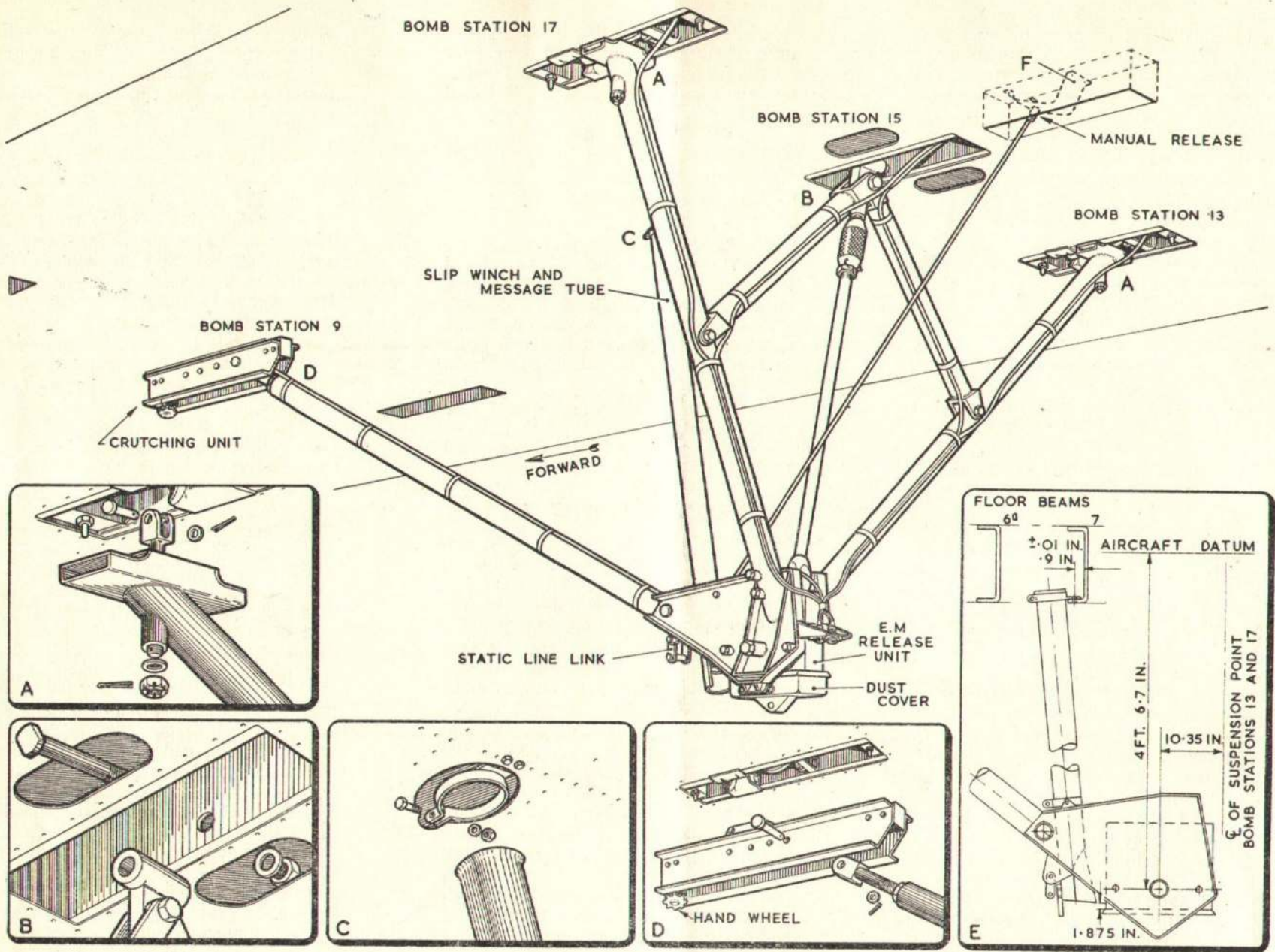

Fig. 3. Mounting of lifeboat carrier

RESTRICTED

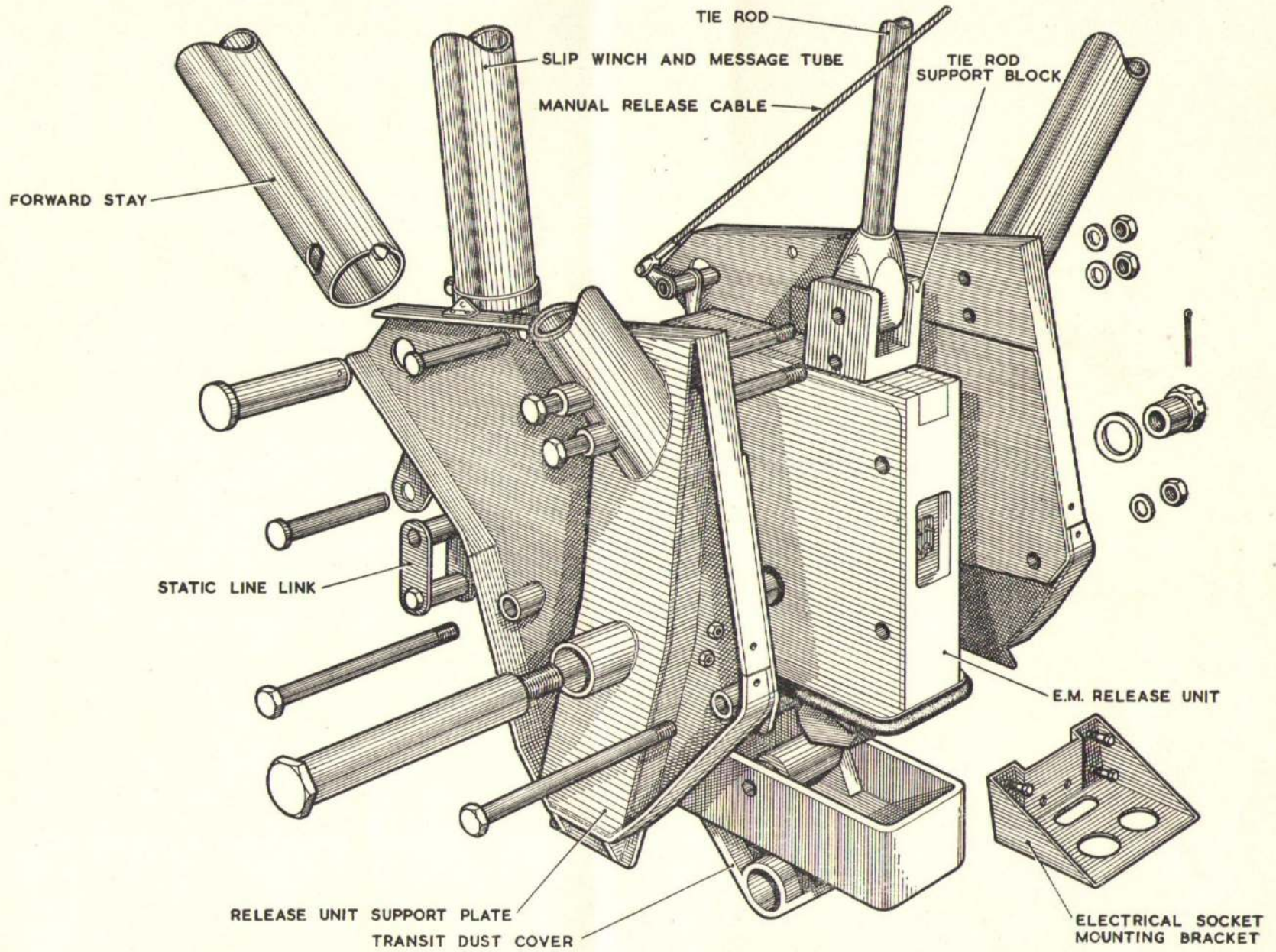

Fig. 4. E.M. release unit assembly

RESTRICTED

SERVICING

RELEASE UNIT TESTING

16. After each drop the release unit should be tested in accordance with A.P.1664A, Vol. 2, Part 3, Sect. 4, Chap. 2, paragraphs 11 and 12. It is recommended that only release tests be made and that any release unit which fails these tests should be returned to an M.U. or Repair Depot and a serviceable unit fitted.

RESTRICTED

This file was downloaded
from the RTFM Library.

Link: www.scottbouch.com/rtfm

Please see site for usage terms,
and more aircraft documents.

