

## Chapter 1 FUSELAGE

### LIST OF CONTENTS

	Para.		Para.		Para.
Introduction ... ..	1	Camera compartments... ..	20	◀ Removal of side windcreens ...	29
Construction ... ..	2	Bomb doors ... ..	21	Fitting a side windscreen ... ..	30
<b>Fuselage sections</b>					
<b>Nose section</b>					
Formers... ..	5	<b>SERVICING</b>			
Parachute exit ... ..	6	Lubrication ... ..	23	Removal of centre windscreen ...	31
Front centre section ... ..	7	Emergency equipment stowages ...	24	Fitting a centre windscreen ... ..	32
Formers... ..	8	Elsan ... ..	25	Air bomber's window ... ..	33
Fittings... ..	9	Dry-air sandwich panels ... ..	26	Fitting a replacement window ...	34
Navigator's table... ..	10	Care and maintenance of Perspex		Auxiliary window ... ..	35
Canopy ... ..	11	panels ... ..	27	Removal of front gunner's	
Intermediate centre section ... ..	12	<b>REMOVAL AND ASSEMBLY</b>			
Ditching exits ... ..	15	General ... ..	28	windscreen ... ..	36
Rear centre section ... ..	16	Dry-air sandwich panels		Fitting of front gunner's	
Retractable scanner ... ..	17			windscreen ... ..	37
Rear section ... ..	18			Removal of front gunner's canopy	38
Tail wheel compartment ... ..	19			Fitting of front gunner's canopy ...	39
				Other transparent panels ... ..	40
				Bomb doors ... ..	41
				Front spar covers ... ..	42

### LIST OF ILLUSTRATIONS

	Fig.		Fig.		Fig.
Nose ... ..	1	Former 12 - rear spar joint ... ..	10	Rear centre section ... ..	18
Stringer-normal former joint, nose	2	Canopy ... ..	11	Retractable scanner ... ..	19
Stringer-former 6, nose ... ..	3	Longeron - front spar joint ... ..	12	Rear section ... ..	20
Stringer-double former joint ... ..	4	Longeron - rear spar joint ... ..	13	Tail wheel compartment ... ..	21
Front centre section ... ..	5	Intermediate centre section ... ..	14	Bomb doors ... ..	22
Stringer-heavy former joint ... ..	6	Stringer - heavy former joint, rear		Canopy glazing and sealing ... ..	23
Former-bomb floor joint ... ..	7	centre section ... ..	15	Removal of bomb doors ... ..	24
Floor beam - longeron joint,		Stringer bracket at transport joint		Removal of front spar covers ...	25
bomb compartment ... ..	8	formers, rear centre section ... ..	16	◀ Sealing of air bomber's window ...	26
Former 6 - front spar joint ... ..	9	Mid-upper turret mounting ... ..	17		

#### Introduction

1. The five sections of the fuselage and locations of crew stations are as follows:-

- (1) Nose section - air bomber's and front gunner's stations.
- (2) Front centre section - first and second pilot's, flight engineer's, wireless operator's and navigator's stations.

- (3) Intermediate centre section - sonobuoy and radar operator's stations.
- (4) Rear centre section - mid-upper gun turret and two air observer's stations.
- (5) Rear section - rear look-out's station.

For transportation, the fuselage divides into four parts, the nose and front centre

sections being carried as one unit. Former positions are given in Sect.2, Chap.4.

#### CONSTRUCTION

2. The five sections, when they are bolted together, form a light-alloy monocoque structure incorporating channel-section formers pressed from light-alloy sheet, excepting those at the

**RESTRICTED**

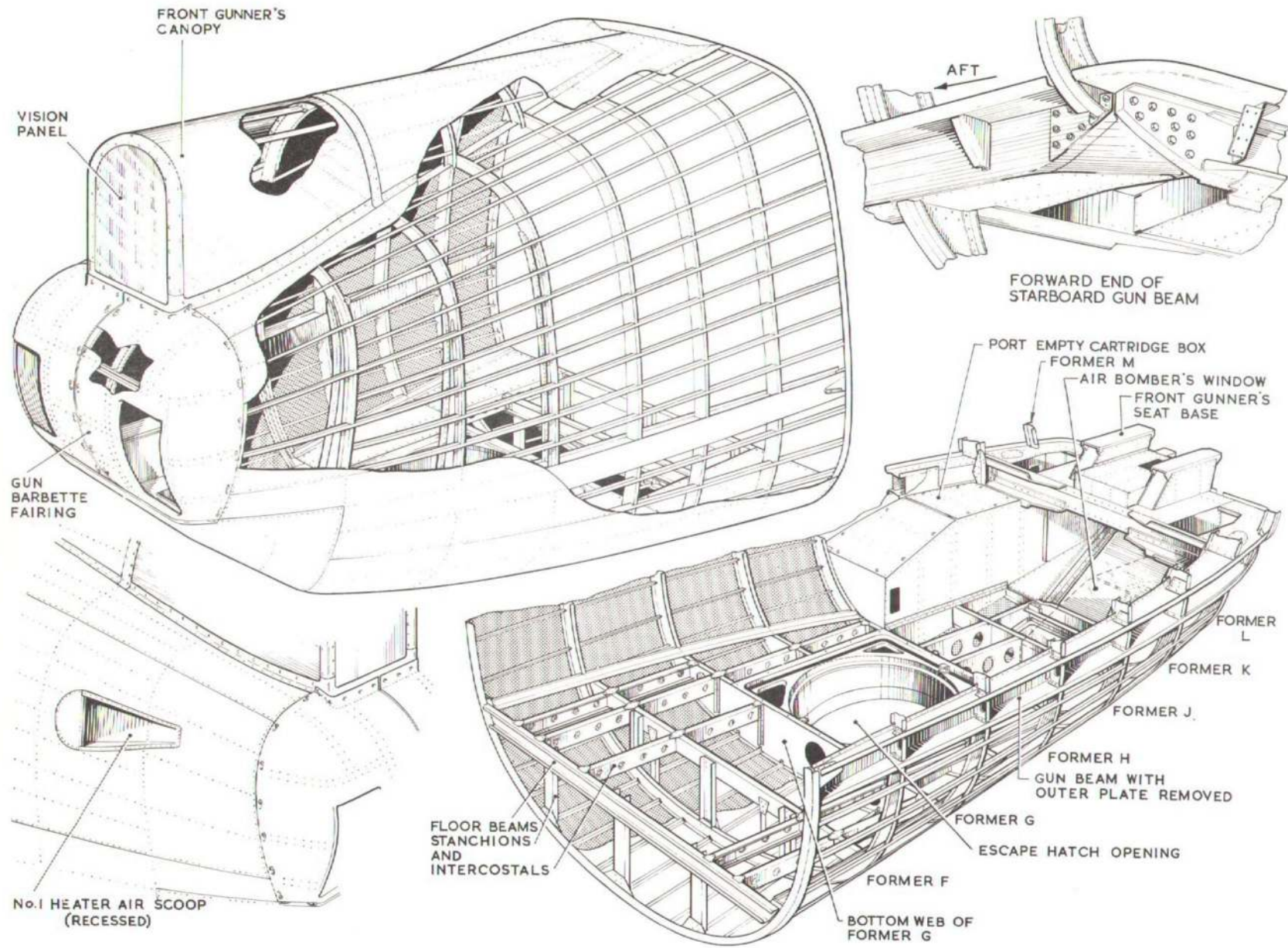

Fig. 1. Nose.

**RESTRICTED**

fuselage joints and other former positions where reinforcement is necessary. These reinforced formers are described in later paragraphs dealing with the fuselage sections. All formers, except the double formers at the joints, are cut away at their outer edges to take angle-section stringers which are attached to them by riveted brackets. Between former E and former '22, the fore and aft limits respectively of the bomb compartment, the fuselage cross-section is constant above the floor. The nose section is tapered to give streamline shape. Aft, from former 22, the fuselage tapers to a point at the extreme end.

3. Formers M to E form the nose section, E to A and 1-6 the front centre section, 6 to 12 the intermediate centre section, 12 to 31 the rear centre section and 31 to 48 the rear section. Aft of former 48 is a transparent tail fairing. Formers 1 to 21 are all of the same contour.

4. The transport joints are at formers 6, 12 and 31 and these, together with the manufacturing joint at former E, consist of front and rear portions providing flanges for bolting the sections together.

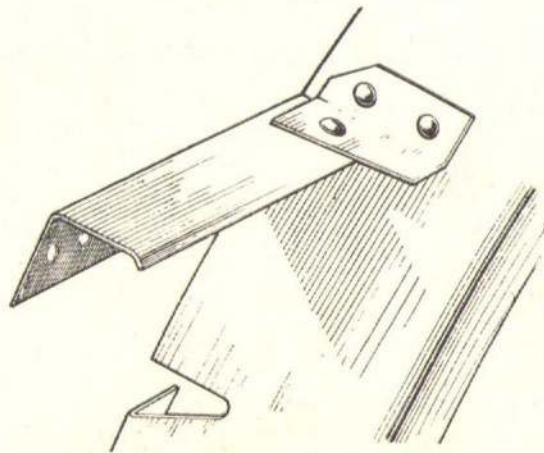

Fig. 2. Stringer—normal former joint, nose

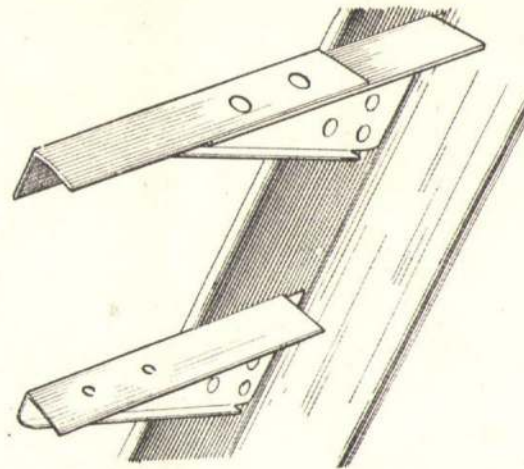

Fig. 3. Stringer—former 6, nose

#### FUSELAGE SECTIONS

##### Nose section (fig. 1)

###### Formers

5. Forward of the front portion of former E, which is at the rear of this section, are formers F to M. To each side of former E, below the mid-point, is attached the aft end of a gunbeam. The two gunbeams extend forward to the tip of the nose. Attached to the underside of the beams are the lower portions of formers F to L, of which that of former H is cut away at an escape hatch and that of former L at the air bomber's window. Between formers K and M are two cockpit rails and the upper ends of formers L and M are attached to these. Former M does not continue below the gunbeams.

###### Parachute exit (fig. 1)

6. This is formed by a flanged circular lower pressing riveted to the edges of a corresponding hole in the skin. An upper pressing is fitted to the square support formed by an intercostal at each side and bulkheads fitted to the lower portions of formers G and J. The space between the cylindrical flanges of these two pressings is filled by a circular strip, the whole forming

a short, smooth skinned exit between the floor and bottom skinning. The door is described in Chapter 11 of this Section.

##### Front centre section (fig. 5)

7. This section, which extends from former E to the main plane front spar (former 6), has a strong floor which forms the roof of the bomb compartment. Extruded longerons, to which the lower ends of the formers are riveted, carry transverse extruded channel-section floor beams. Between these beams are pressed channel-section intercostals with end flanges which are riveted to the beams. The floor surface plating is riveted to the floor beams and intercostals. Hinges for the bomb doors are bolted to the lower edges of the longerons and sealing strip is secured to the longerons between the hinges (fig. 22).

##### Formers

8. Former E is of extruded channel section and incorporates a bulkhead below floor level which forms the forward end of the bomb compartment. Formers A to F come to an end on each side at two cockpit rails and B, C and D are of heavy rolled-plate channel section. Formers 1, 3 and 4 are pre-fabricated from extruded angle section riveted to heavy gauge webs.

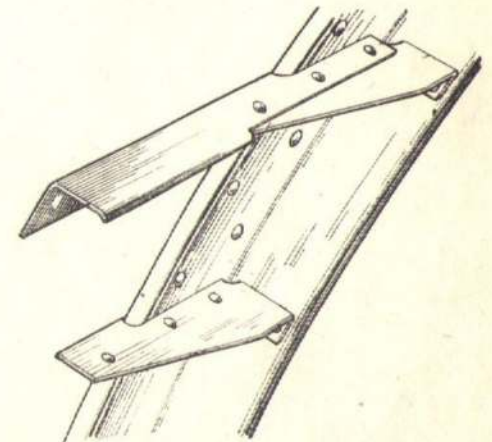

Fig. 4. Stringer—double former joint

(A.L.82, Mar. 55)

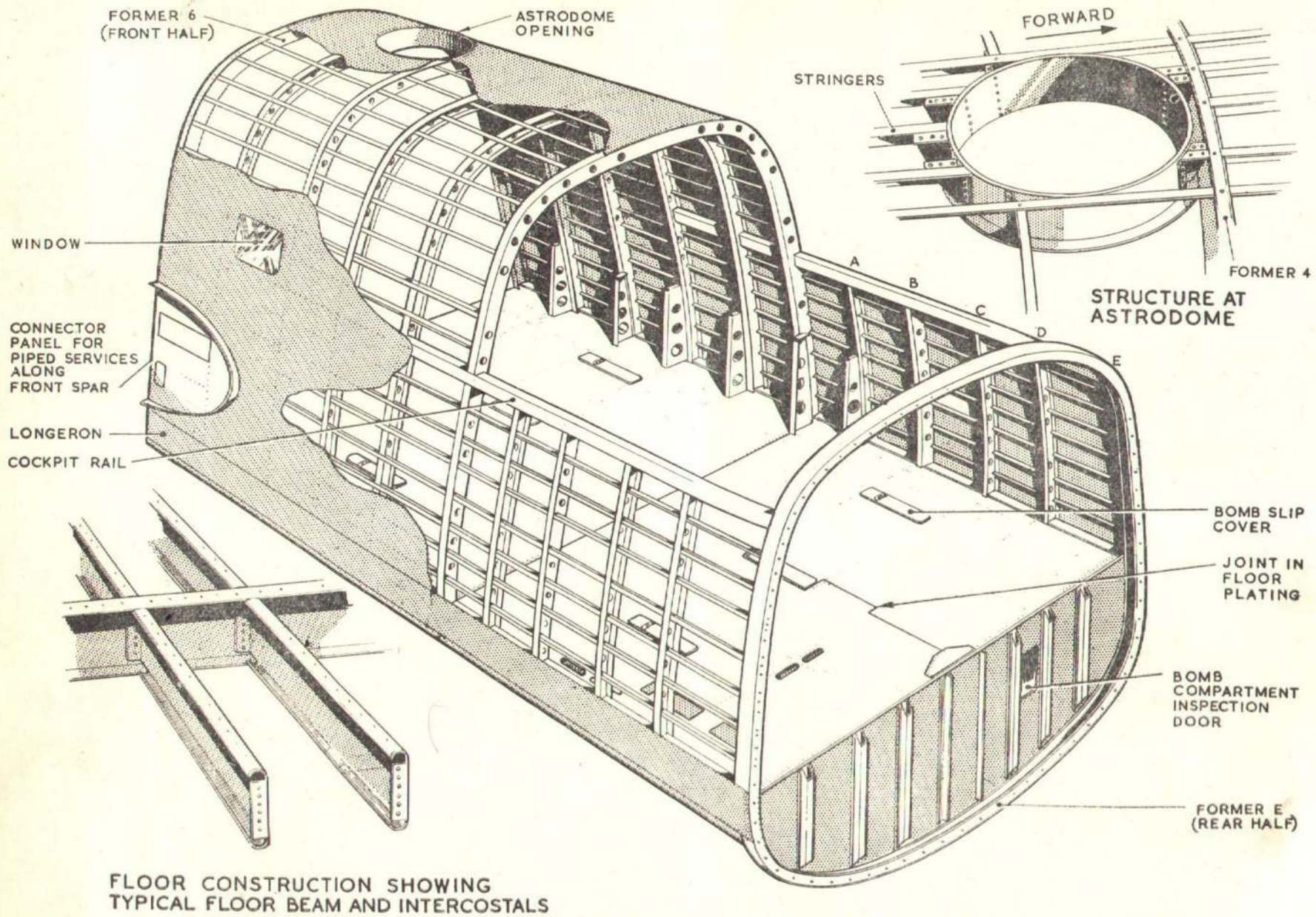

Fig. 5. Front centre section

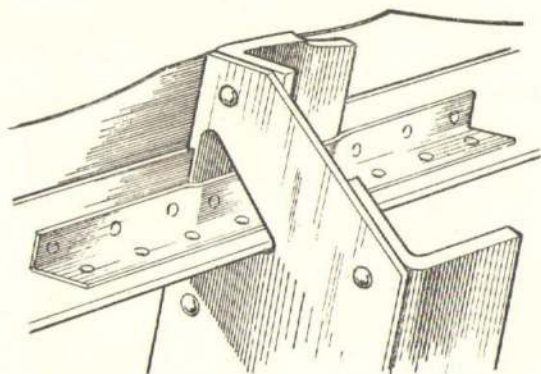

Fig. 6. Stringer—heavy former joint

**Fittings**

9. In the floor are six bomb gear housings which consist of heavy channel-section intercostals, each with triangular lightening holes in the web, fitted with their flanges facing outwards (Sect. 7). In the cockpit above the main floor are two pilot's floors. They are each supported on four inverted V-shaped tubular members, lateral bracing being provided by attachment brackets between the outboard edges of these floors and the fuselage sides.

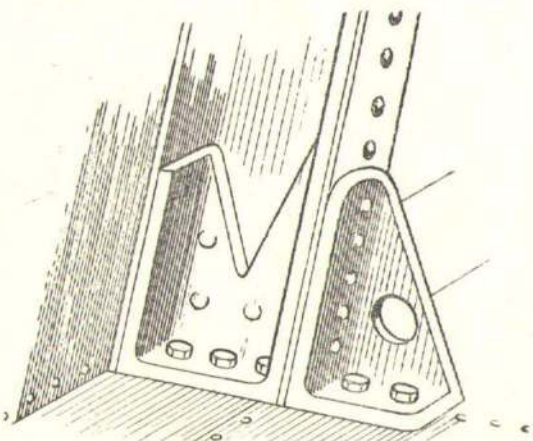

Fig. 7. Former—bomb floor joint

**Navigator's table**

10. Extending from between formers 2 and 3 to former 6 at the front spar, the table serves three crew members. It is illustrated and described in Sect. 3, Chap. 16.

**Canopy (fig. 11)**

11. Forward of former 1 the front centre section is faired over by the canopy—a tubular framework glazed with transparent material forward and covered by plating aft. At the front is the pilot's windscreen which is a die-cast frame with three dry-air-sandwich type vision panels. At one of the upper corners of each of these panels is a self-sealing valve (fig. 11) to which is connected a dry-air system. The outer panels of the die-cast frame assembly are each divided into an upper and a lower panel. In each upper panel is fitted a direct-vision window and the lower panel is glazed with transparent material. At each side of the roof is an escape hatch.

**Intermediate centre section (fig. 14)**

12. The cross-sectional area is uniform throughout and construction is similar to that of the rear part of the front centre section, except for the floor which is heavier.

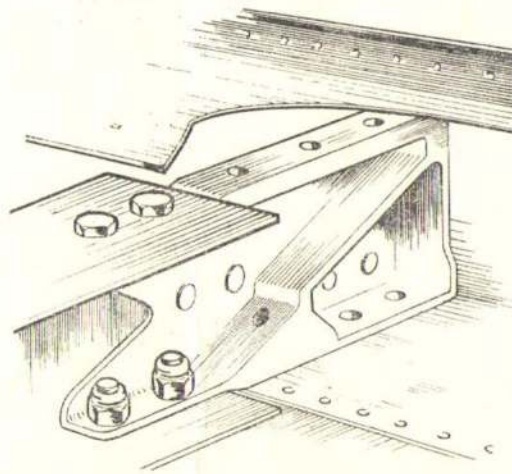

Fig. 8. Floor beam—longeron joint, bomb compartment

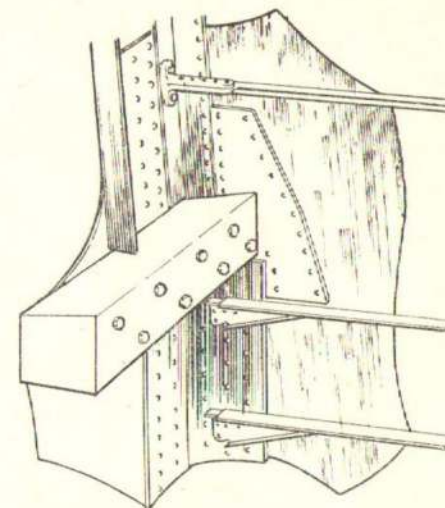

Fig. 9. Former 6—front spar joint

Formers 6 and 12 are integral with the front and rear main plane spars and, together with former 8 and 9, are of prefabricated angle-and-web construction. Formers 8 and 9 are reinforced at their highest point.

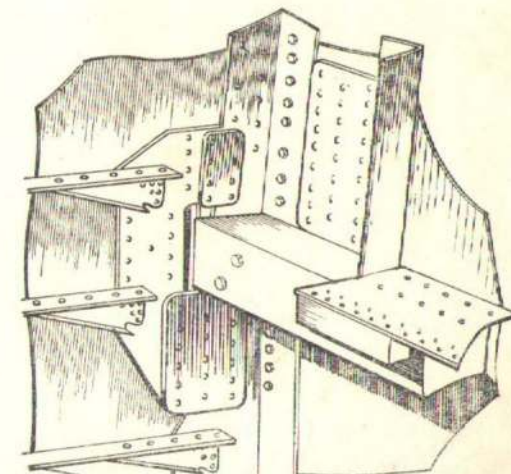

Fig. 10. Former 12—rear spar joint

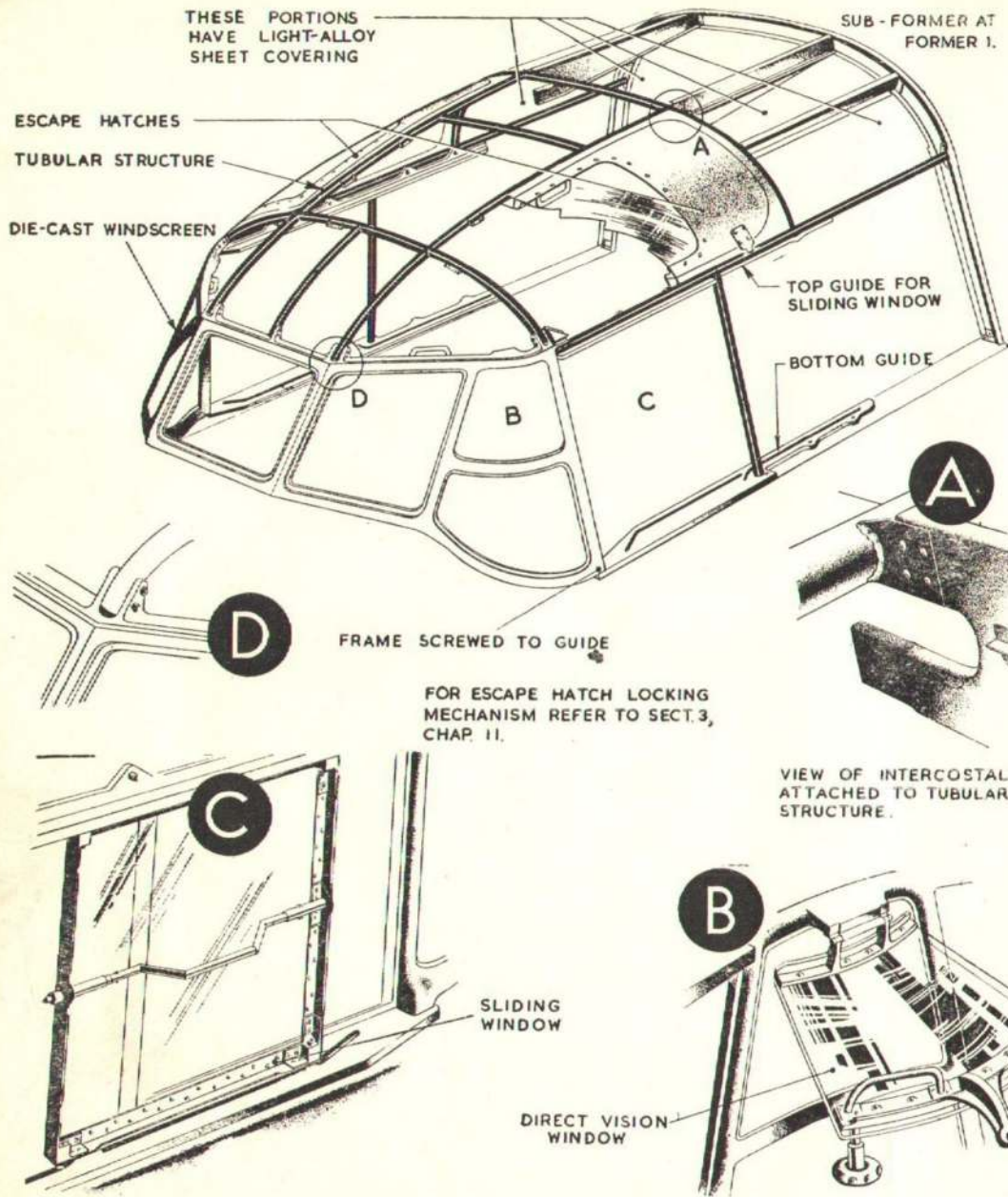

Fig. 11. Canopy

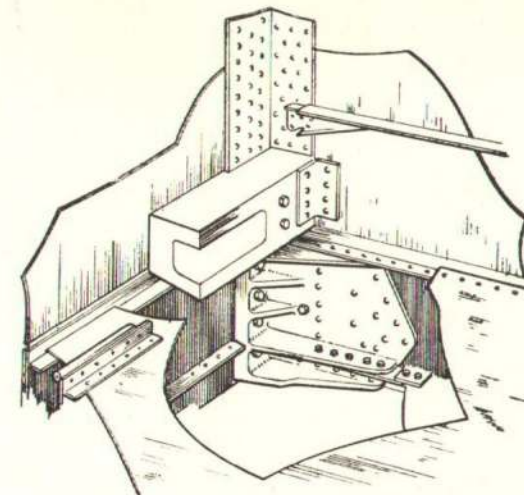

Fig. 12. Longeron—front spar joint

13. Between floor beams 8 and 9 (both positioned under the formers of corresponding numbers) a heavy bomb slip is fitted. These two beams are, therefore, supported centrally by two tie-rods secured at their upper ends to the reinforced part of former 8 and 9.

14. Extruded angle-section members are riveted to the outside of the skinning to provide for the attachment of the inboard edges of the main plane centre section skinning.

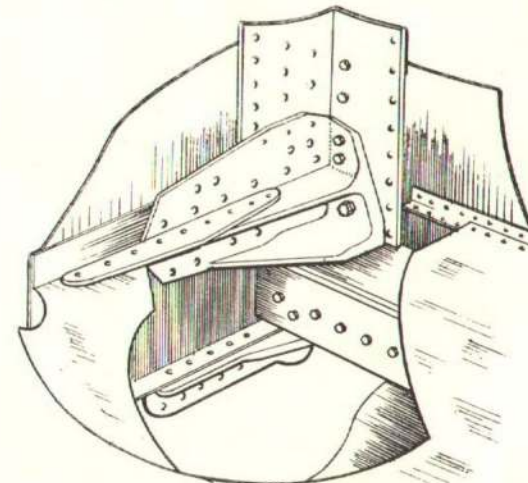

Fig. 13. Longeron—rear spar joint

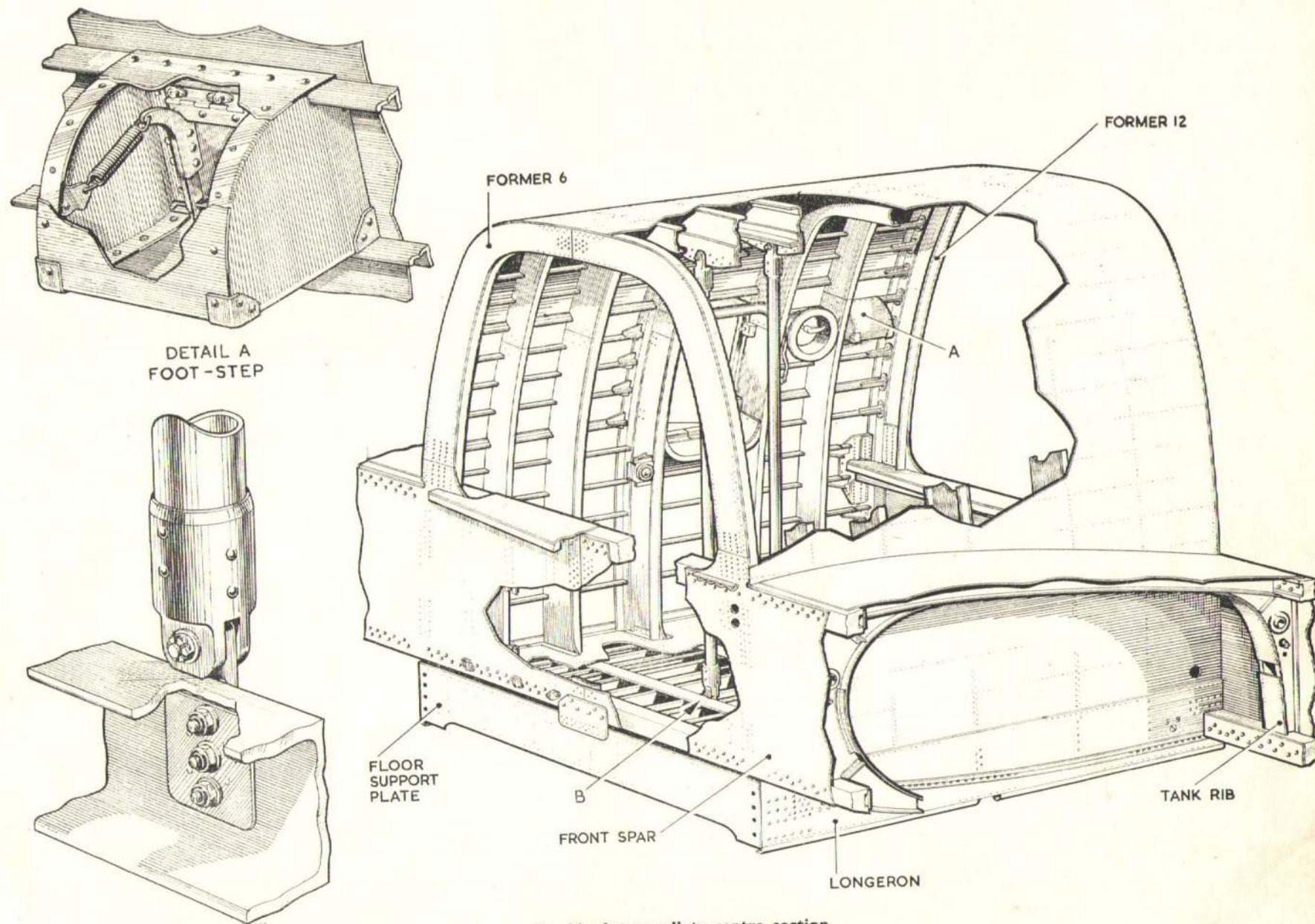

Fig. 14. Intermediate centre section

RESTRICTED

#### Ditching exits

15. On either side of the fuselage, between formers 9 and 10, is a ditching exit which opens on to the upper surface of the main plane. The opening is bounded by part of formers 9 and 10 and top and bottom members with curved ends which round off the corners. The door is described in Chapter 11 of this Section.

#### Rear centre section (fig. 17 and 18)

16. This section extends from former 12 at the rear spar to former 31 which is aft of the entrance door. This is on the starboard side, between formers 27 and 29. In the roof, between formers 14 and 17, is the mid-upper turret mounting (fig. 20). A bulkhead, below the floor at former 22, forms the aft end of the bomb compartment. The bomb floor is similar to that of the nose and front centre section and incorporates six bomb slips. Aft of former 22, the floor is of lighter construction. The structure around the opening for the scanner is shown in fig. 18.

#### Retractable scanner (fig. 19)

17. Two hydraulic jacks operate the retractable scanner fairing which is in two sections arranged to telescope when the fairing is retracted. The cupola is rigidly attached to the ends of the jack piston-rods.

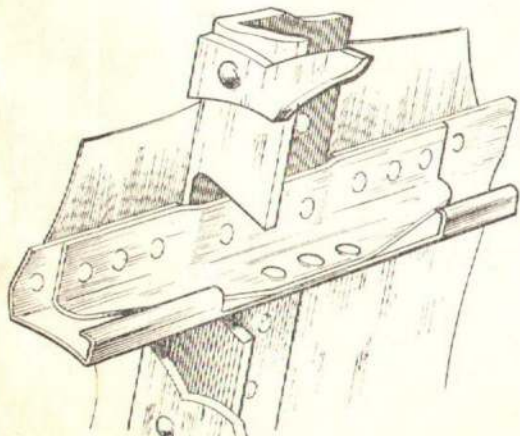

Fig. 15. Stringer—heavy former joint, rear centre section

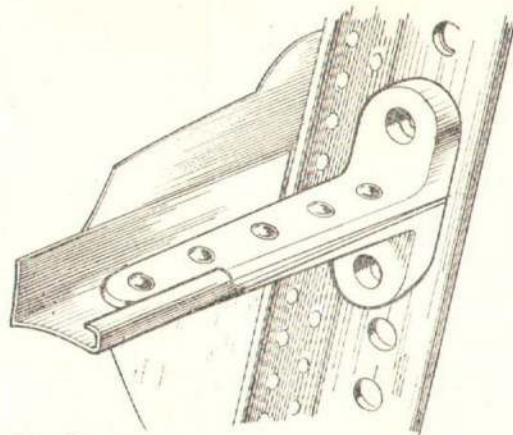

Fig. 16. Stringer bracket at transport joint formers, rear centre section

#### Rear section (fig. 20)

18. The rear section is an assembly of three components: (1) The main portion extending from former 31 to former 44 which consists of front and rear portions forming a joint; (2) The rear portion of former 44 which is integral with an extension which ends at former 48; (3) Aft of former 48, consisting of a transparent fairing which tapers to a point. Formers 37 and 41 are of heavy prefabricated construction and carry fittings to which the tail plane is bolted (*this Section, Chapter 3*). All floor plating in the illustration is omitted to show the floor construction.

#### Tail wheel compartment (fig. 21)

19. Reinforced bulkheads at the lower portions of former 37 and 41 carry brackets at which the retractable tail wheel assembly and the anchored end of the hydraulic jack are pivoted. A cover, inside the rear section, is attached to the upper edges of the two bulkheads and to the fuselage structure at the sides and forms a compartment into which the tail wheel retracts. An UP-lock catchpin assembly is secured to the top of the compartment. This is described in Chapter 5 of this Section.

#### Camera compartments (fig. 20)

20. There are two compartments, one between former 42 and 44 and the other between formers 45 and 47. Each of these four formers incorporates a bulkhead at its lower portion and between each pair of bulkheads are fitted the compartment sides to form a rectangular bay. A rectangular plate at the top of each bay incorporates an attachment ring to which the camera mountings are fitted. Space for the cameras is provided by a raised floor structure which is shown in the illustration. This structure, of which the aft part is raised above the forward part to allow for the taper of the underside of the rear section, is covered with plating to form the floor. The opening between each compartment is faired over by two doors which are operated by links attached to the camera cupola. Each door consists of a dished pressing with two flanged lightening holes which forms the inner surface. The pressing is stiffened by two double, pressed ribs and covered with a light-alloy skin which is spot welded to the outer flange and to the flanges around the lightening holes. The doors are secured to the sides of the openings by piano-type hinges.

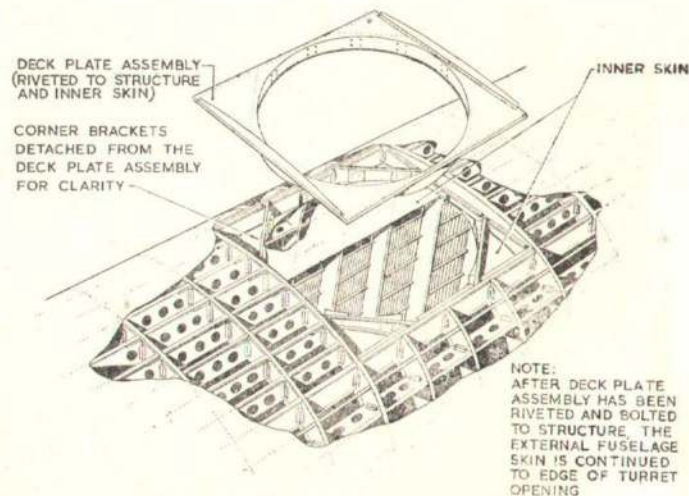

Fig. 17. Mid-upper turret mounting

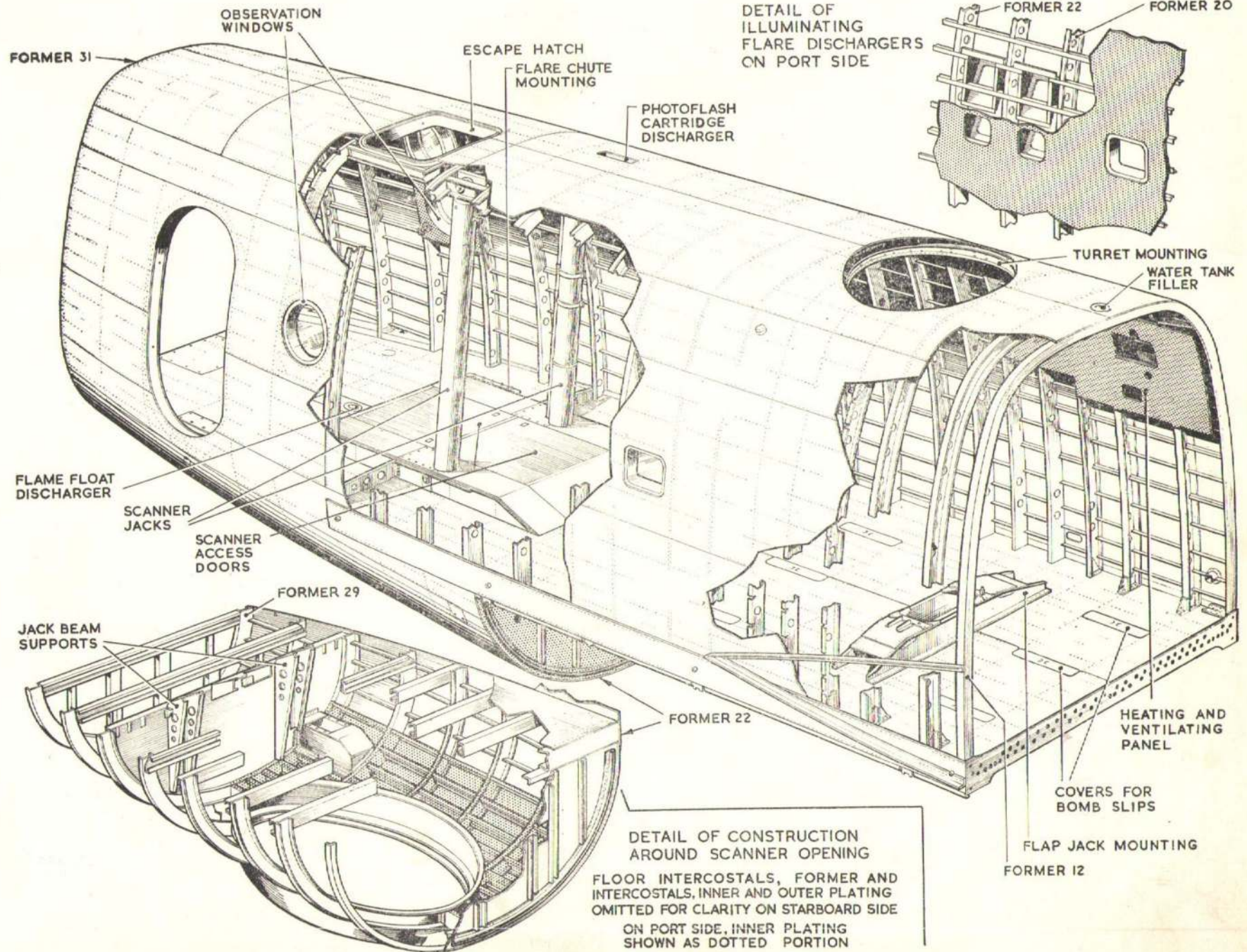

Fig. 18. Rear centre section

NOTE:- FLOOR PLATING  
AND ACCESS DOORS  
BETWEEN JACK SUPPORT  
BEAMS OMITTED FOR  
CLARITY

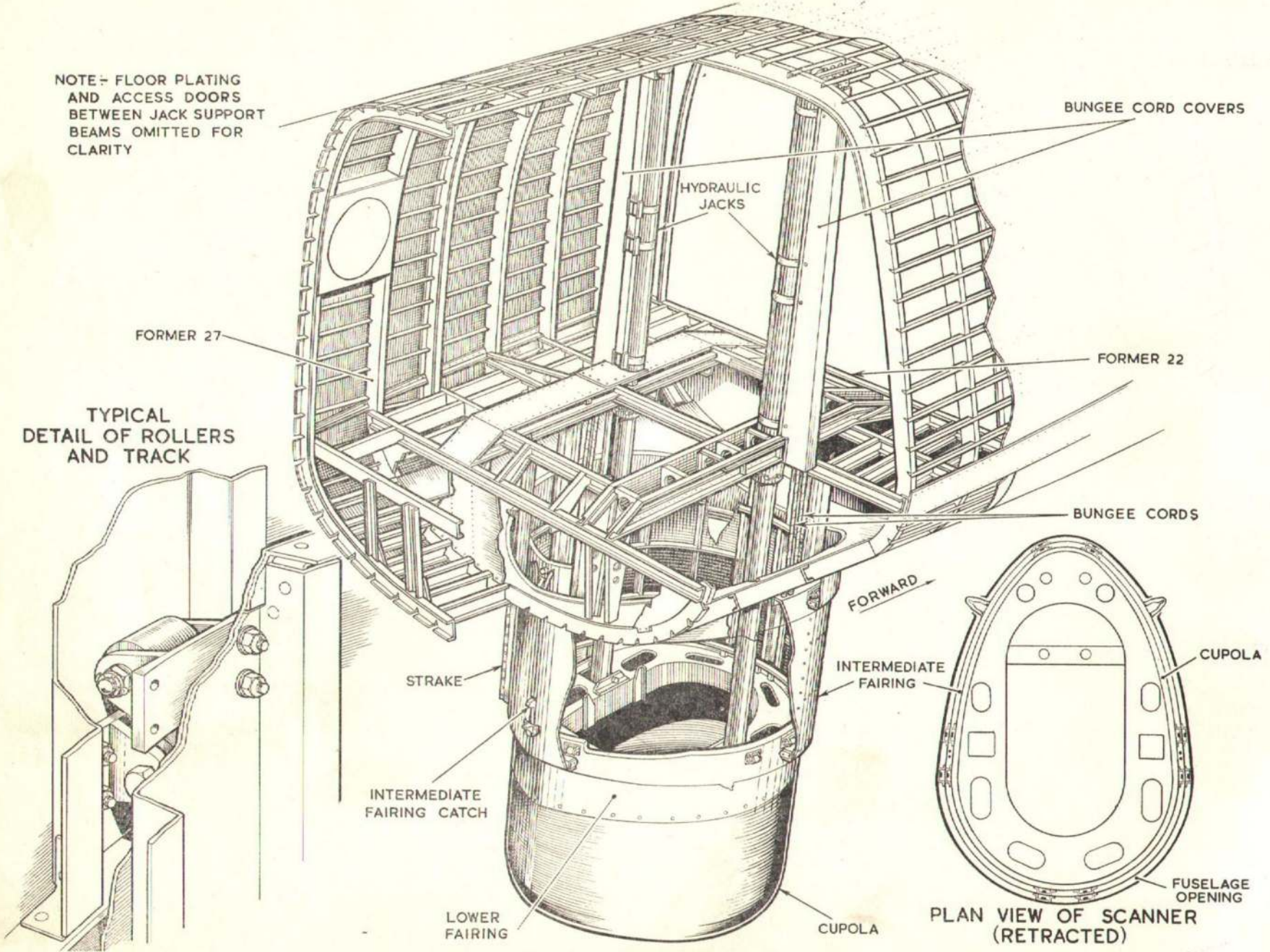

Fig. 19. Retractable scanner

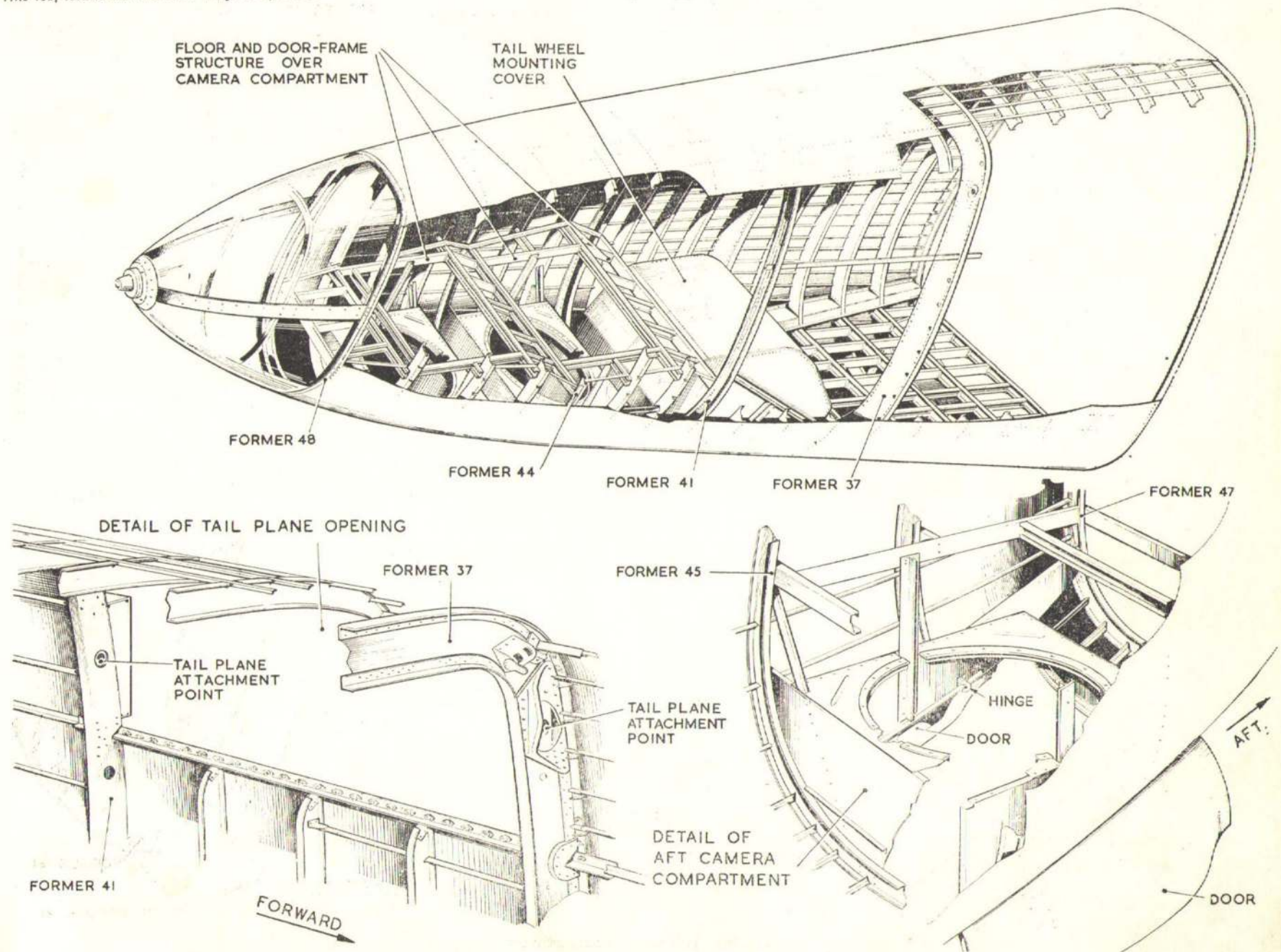

Fig. 20. Rear section

RESTRICTED

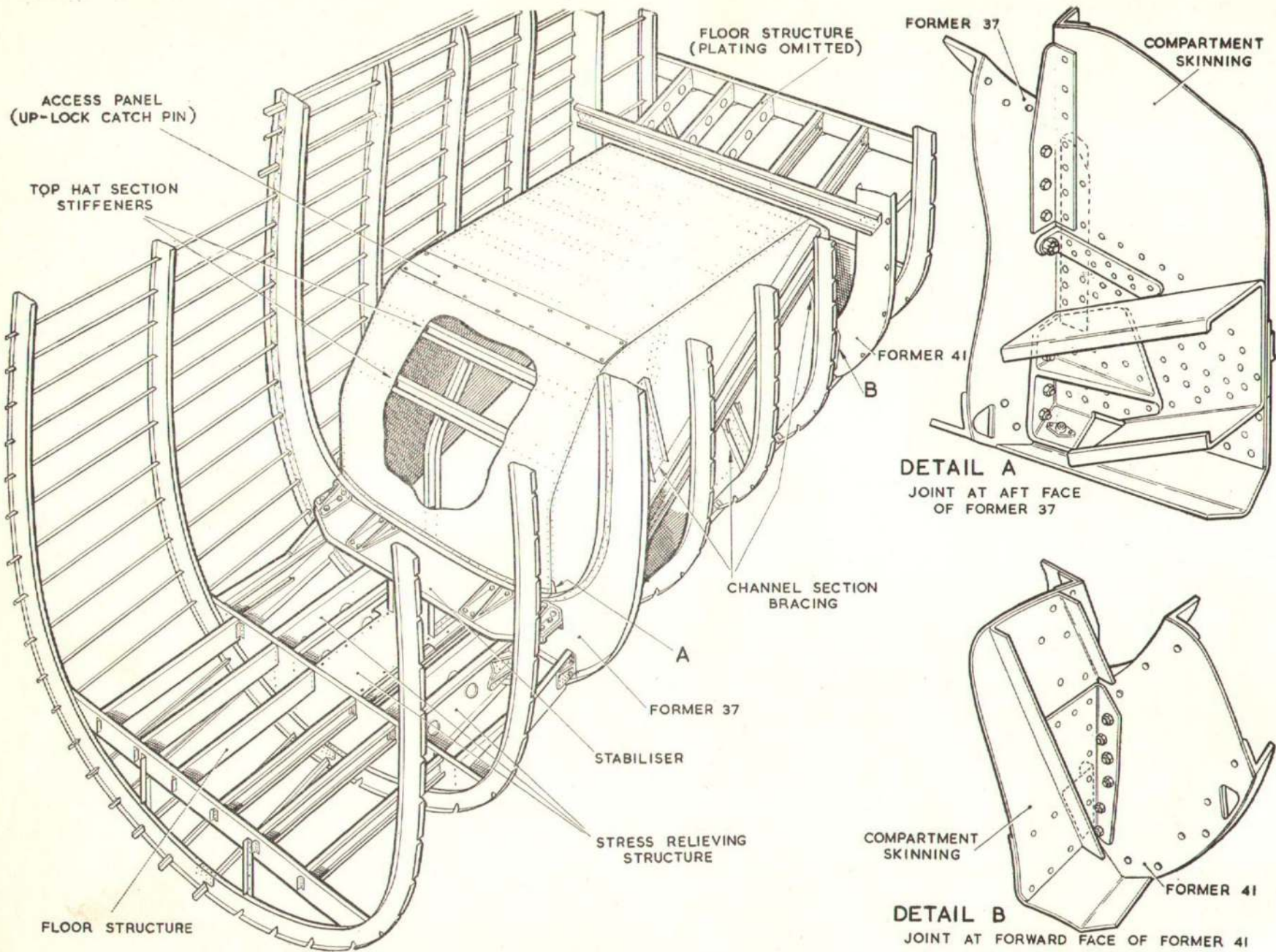

Fig. 21. Tail wheel compartment

**BOMB DOORS (fig.22)**

21. Between formers E and 22, the lower sides and undersurface of the fuselage are formed by the bomb doors. They are constructed of light alloy and each is built up on a centre spar consisting of a web plate with four lengths of extruded angle section, riveted to it to form an I-section beam. To each end of the spar is attached a double rib, consisting of two webs spaced and reinforced by

lengths of channel section which incorporate lightening holes. Detail C in the illustration shows the method of attachment of the operating-jack piston-rod to each end-rib.

22. All intermediate ribs are in two parts attached to the central spar. The upper edge or hinge beam of each door consists of a length of extruded channel section which incorporates an integral lip (detail A), which acts as a draught excluder, in conjunction with a

hook-section strip riveted to the longeron between the hinges (detail B). The hinge spindles are bolts which allow for removal of the doors. The lower edge of each door is a length of pressed-sheet channel section. A false edge on the starboard door and a length of rubber extrusion act as a seal when the doors are closed (detail D). Removal of two inserts in the lower edges of both doors permit them to be closed when the lifeboat suspension gear is fitted.

**SERVICING****LUBRICATION**

23. All escape hatches, the main entrance door and parachute exit are dealt with in Chapter 11 of this Section. The minimum necessary quantity of oil, OM-150 or OX-14, must be used to lubricate the hinges and screw clamps for the direct vision windows and the locking control and retaining grooves for the sliding windows at each side of the cockpit. Compartment door hinges are lubricated with oil OM-150 and the check cables on the seat safety harnesses with oil OM-13 when necessary.

**EMERGENCY EQUIPMENT STOWAGES**

24. Checks are to be made at frequent intervals of the serviceability of the external and internal means of access to the first-aid kit in the fuselage rear section (Sect.1, Chap.3), and the operation of the catches of the removable panel in the lower part of the main entrance door.

**ELSAN**

25. It is important that the sewage is always covered by liquid, if necessary add water occasionally. At the specified times, remove the container, a wire handle is provided, empty it and swill it out with water. Recharge the container with fluid Ref.No.33F/400. The elsan is mounted on an anti-spillage tray which has rounded raised edges to confine spillage and is painted with two coats of acid resisting paint Ref.No.33A/9428699, 9428700 or 9428701. Periodic checks of the tray are to be made to ensure that the coating of paint is intact.

**DRY-AIR-SANDWICH PANELS**

26. If any panel is suspected to be leaking a pressure test may be carried out as a check. Use an A.S.I. test pump and manometer and test at a pressure not exceeding  $\frac{1}{2}$  p.s.i. If this pressure is

held over a period of 15 minutes without sensible drop, the panel is serviceable. If pressure cannot be built up, as will often happen in unserviceable panels, check all connections before placing the panel unserviceable. The method of changing a panel is described in para.30.

**CARE AND MAINTENANCE  
OF PERSPEX PANELS**

27. Great care must be taken when cleaning and polishing transparent panels and fairings since the material is easy to scratch. Certain liquids, if they are allowed to spill on the transparent material, cause it to "craze". All relevant information is contained in A.P.1464D, Vol.1.

**NOTE...**

At suitable intervals apply Boscolite primer Ref.No.33H/9429604 to all exposed edges of the Prestik filling at the edges of panels likely to be contaminated by windscreen de-icing fluid.

**RESTRICTED**

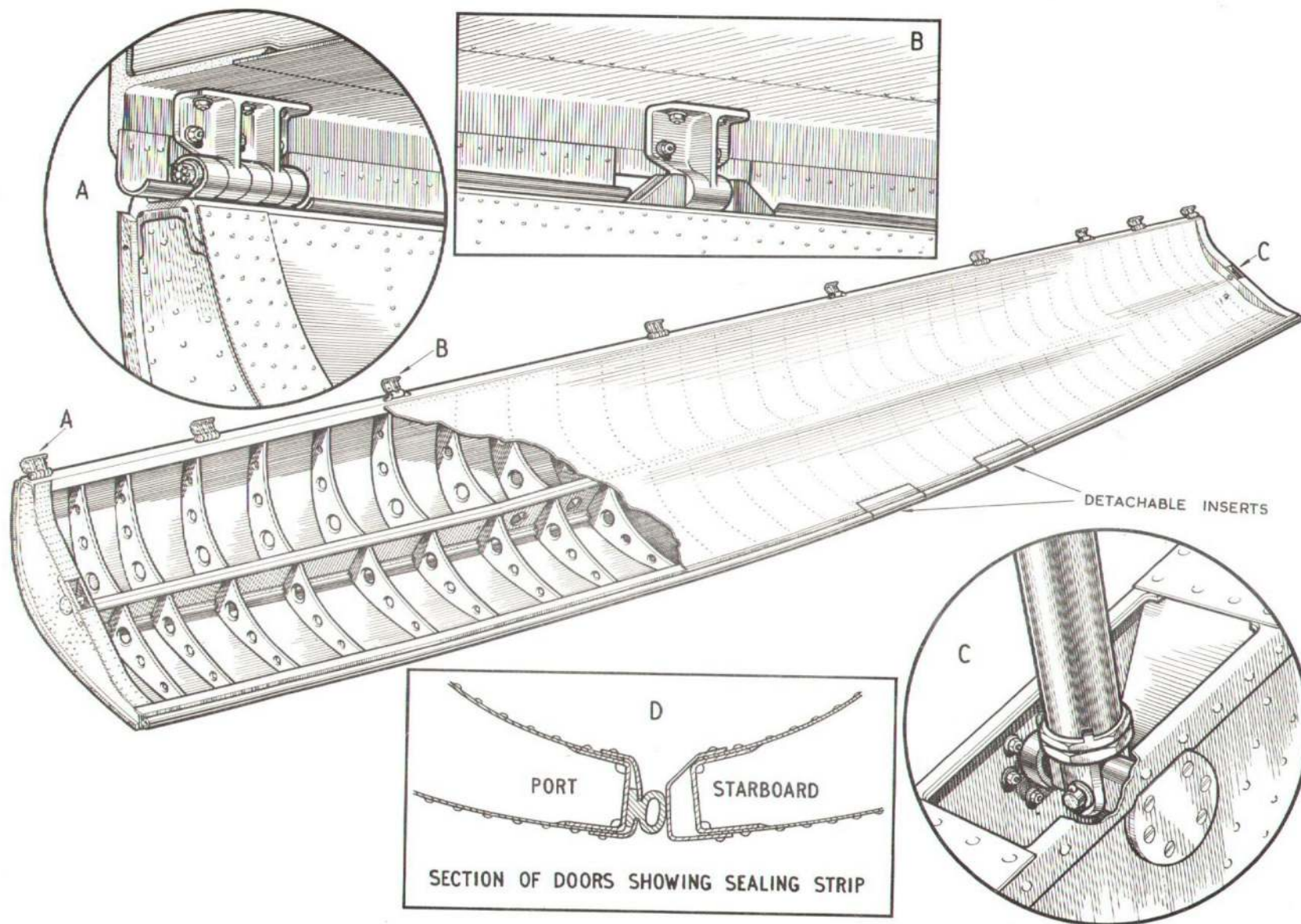

Fig. 22. Bomb doors

**RESTRICTED**

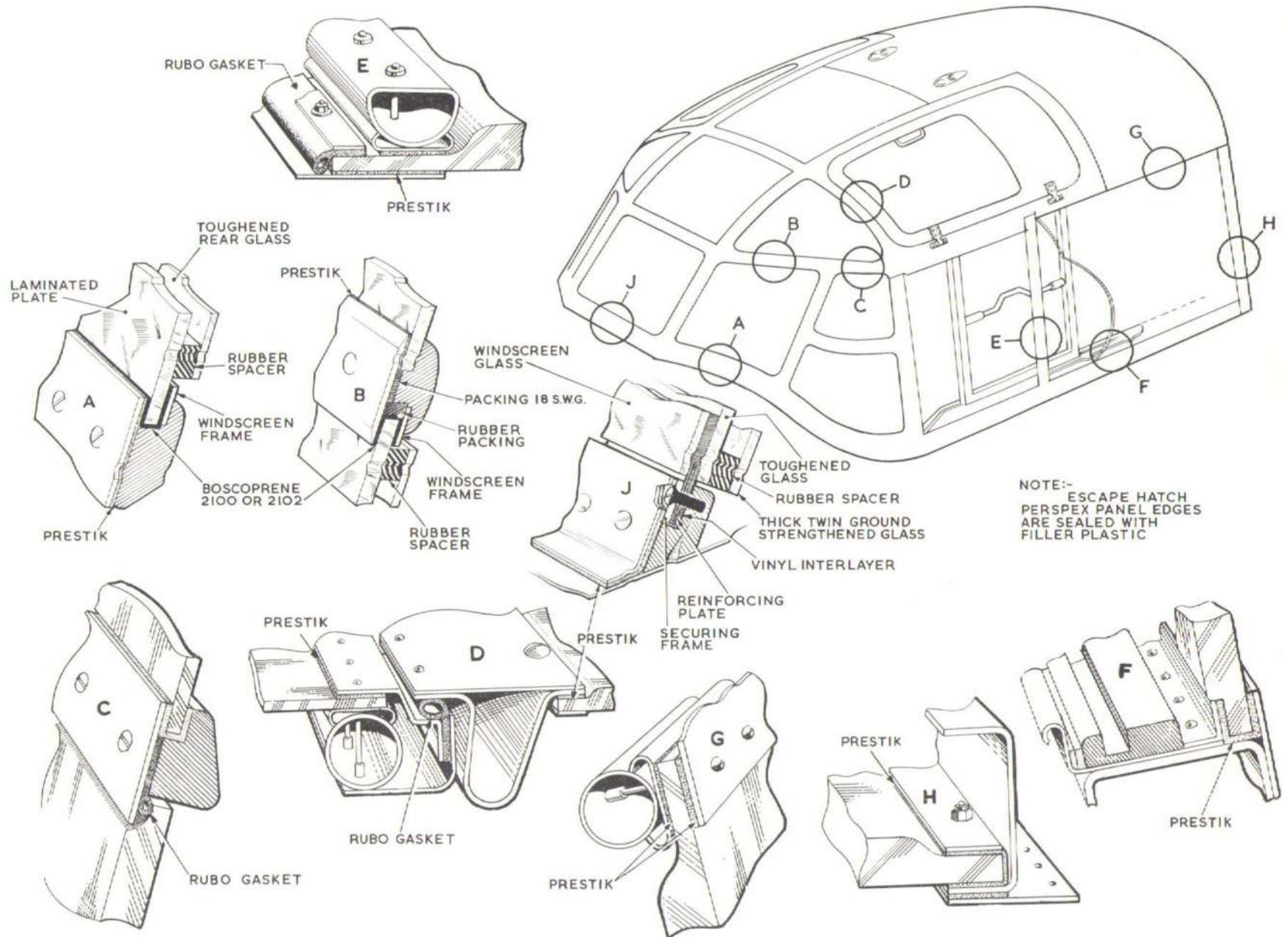

Fig. 23. Canopy glazing and sealing.  
( Amendment of sealing )

**RESTRICTED**

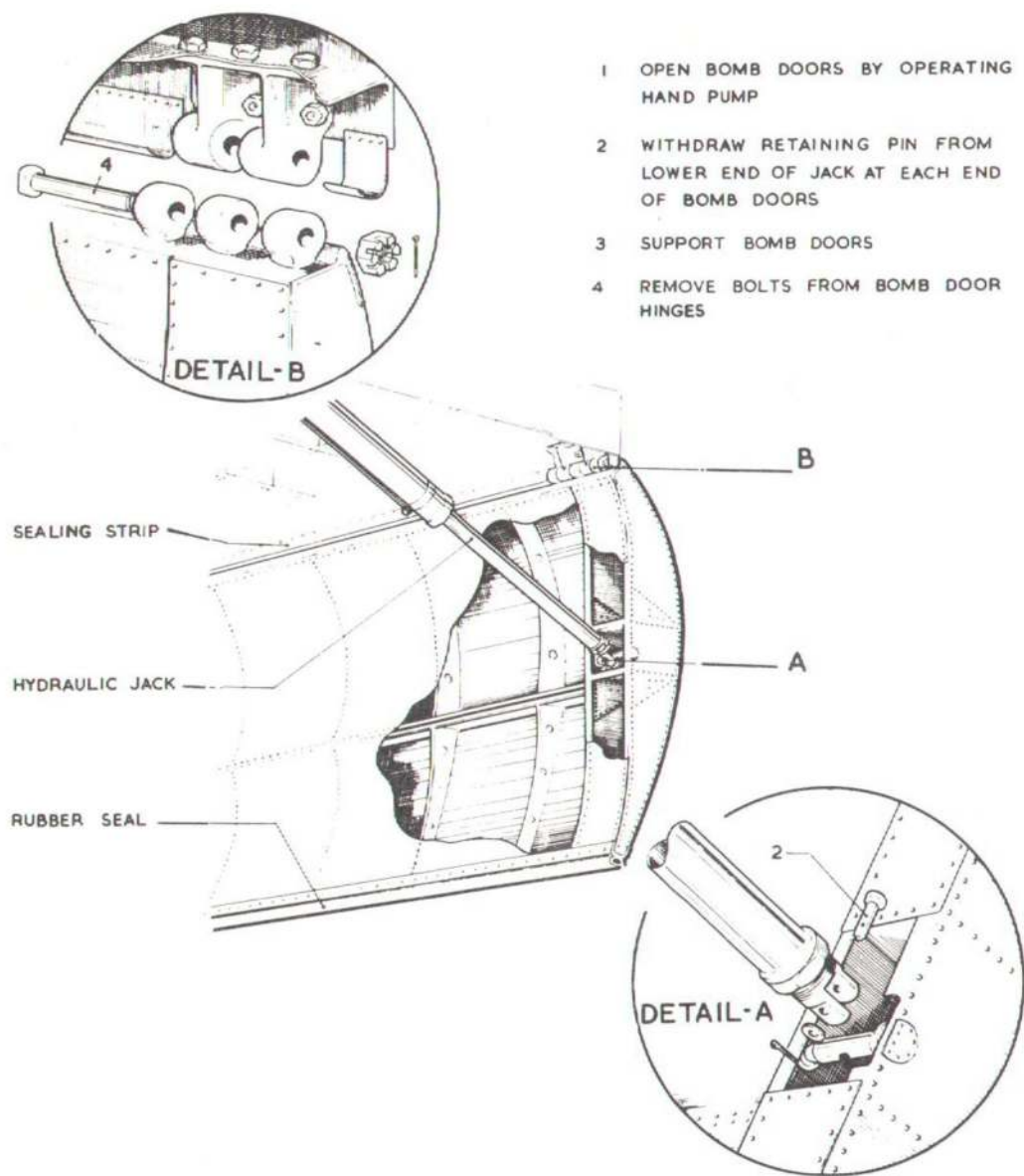

Fig.24. Removal of bomb doors

RESTRICTED

## REMOVAL AND ASSEMBLY

### General

28. Minor operations, of a special nature only, relating to the fuselage, are described in the following paragraphs:-

### DRY-AIR SANDWICH PANELS (fig.23)

#### Removal of side windcreens

29. To remove a side windscreen, proceed as follows:-

- (1) Disconnect the de-misting system breather pipe from the dehydrator valve at the upper corner of the panel and blank off the pipe immediately.
- (2) Remove the metal securing strips round the panel on the outside of the frame.
- (3) Remove all the Prestik plastic filler from beneath the bottom securing strip until the panel can be eased out of its frame.

#### Fitting a side windscreen (fig.23)

30. To fit a replacement side windscreen, proceed as follows:-

- (1) Thoroughly clean the frame and ensure that the rubber packing and backing frame are in good condition.

#### WARNING...

*It is important that the frame be thoroughly clean, to allow the panel to seat evenly in the frame rebate, otherwise damage may result when fitting the metal securing strips.*

- (2) Test the new panel (para.26) before fitting it.
- (3) Apply Boscoprene (Ref.No.33H/50 or 53) round the edges of the panel and seal the panel into the frame.

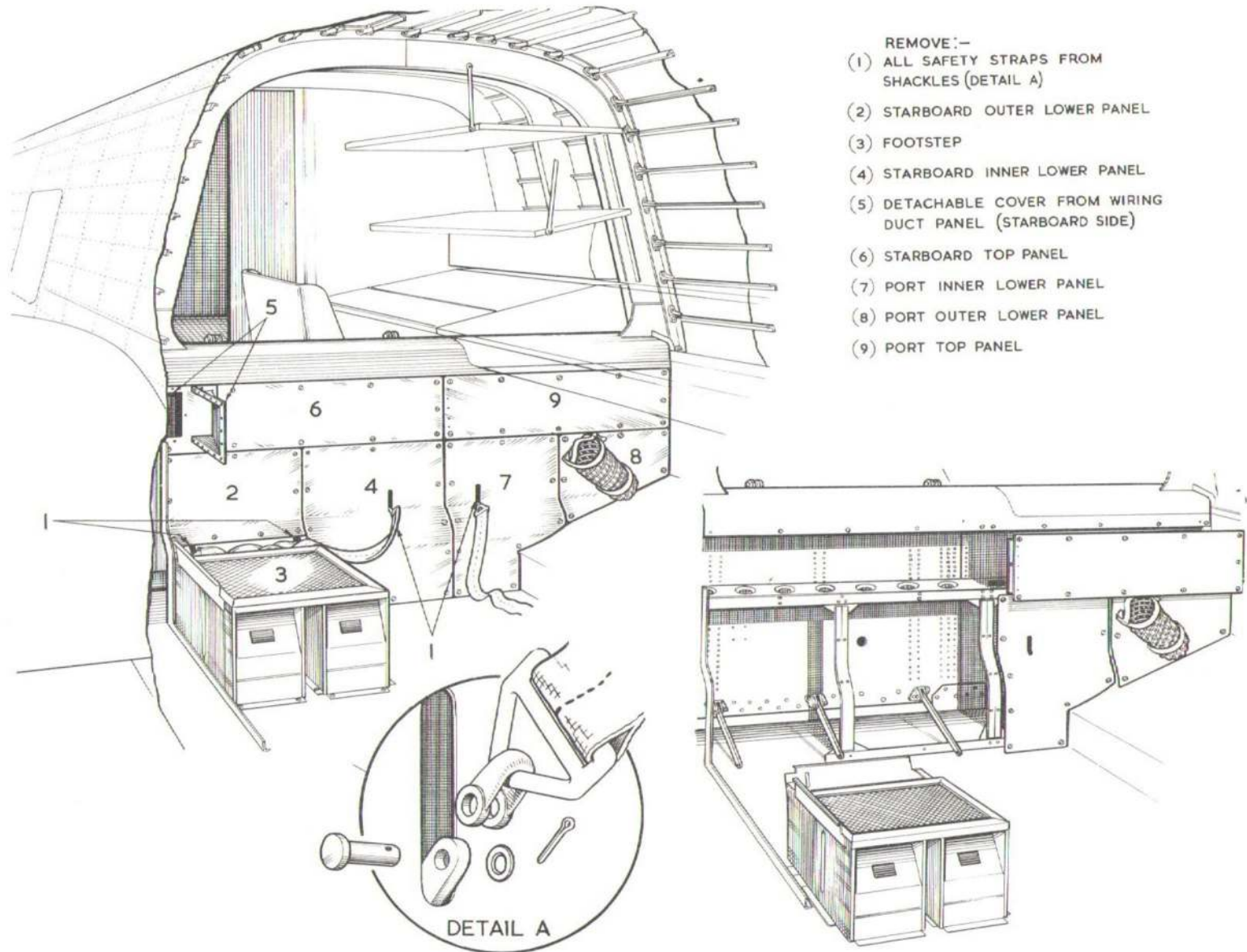

Fig.25. Removal of front spar covers.

**RESTRICTED**

- (4) Apply Prestik filler (Ref.No.33H/148) over the area to be covered by the bottom securing strip (detail A).
- (5) Fit the metal securing strips, taking care not to over-tighten the screws. Finish off the edges of the plastic filler and Boscoprene as shown in the illustration and apply one coat of Boscolite primer (Ref.No.33H/9429604) to the exposed edges of the Prestik filler and Boscoprene.
- (6) Test the new panel again at this stage (para.26).
- (7) Remove the blanking plug from the de-misting pipe and connect the pipe to the valve on the new panel.

#### Removal of centre windscreen

31. The removal sequence for the centre panel is as follows:-

- (1) Disconnect the de-misting system breather pipe (para.29(1)).
- (2) Remove the metal securing strips round the panel on the outside of the frame.
- (3) Remove all the plastic filler from beneath the bottom securing strip.
- (4) Remove the 36 screws which secure the securing frame and the Vinyl interlayer to the windscreen casting. Retain the screws.
- (5) Ease the panel out of its frame.

#### Fitting a centre windscreen

32. To fit a replacement centre windscreen, proceed as follows:-

- (1) Thoroughly clean the frame.

#### WARNING...

*It is important that the frame be thoroughly clean, to allow the panel to seat evenly in the frame rebate, otherwise damage may result when fitting the metal securing strips.*

- (2) Test the new panel (para.26) before fitting it.
- (3) Fit the panel into the windscreen frame complete with securing frame and screws. Ensure that the panel is seated correctly by tightening the screws in rotation. Do not overtighten the screws, and pop-lock them in position.

#### NOTE...

*The 12 screws (Ref.No.26FF/1597) along the top of the frame are 2 B.A. with 120 deg. countersunk heads and are 0.5 in. long. The remaining 24 screws (Ref.No.26FF/1598) are 2 B.A. with 120 deg. countersunk heads and are 0.63 in. long.*

- (4) Apply Prestik filler (Ref.No.33H/148) over area to be covered by the bottom securing strip.
- (5) Fit the metal securing strips, taking care not to overtighten the screws. Apply one brushcoat of Boscolite primer (Ref.No.33H/9429604) to the exposed edges of the Prestik filler.
- (6) Test the new panel again at this stage (para.26).
- (7) Remove the blanking plug from the de-misting pipe and connect the pipe to the valve on the new panel.

#### AIR BOMBER'S WINDOW (fig.26)

33. To remove the air bomber's window, proceed as follows:-

- (1) Disconnect the de-icing and fresh water pipes from the spray assembly at the top of the window and blank off the pipelines.
- (2) Remove the spray assembly.
- (3) Remove the sealing strips from the edges of the panel.
- (4) Remove all the plastic filler from beneath the sealing strips.
- (5) Remove the screws securing the cover strip and the Vinyl interlayer to the windscreen casting and ease out the panel.

#### Fitting a replacement window

34. To fit a replacement window, proceed as follows:-

- (1) Thoroughly clean the frame.
- (2) Secure the window into the frame rebate with a few screws and check that there is a gap of between 0.07 in. and 0.15 in. between the edge of the outer glass layer and the windscreen frame (section A-A)
- (3) Remove the window from the frame rebate.
- (4) Apply Prestik filler (Ref.No.33H/150) all round the frame rebate.
- (5) Fit the new panel complete with cover strips and screws.
- (6) Apply Prestik filler (Ref.No.33H/148) over the area to be covered by sealing strips.

**RESTRICTED**

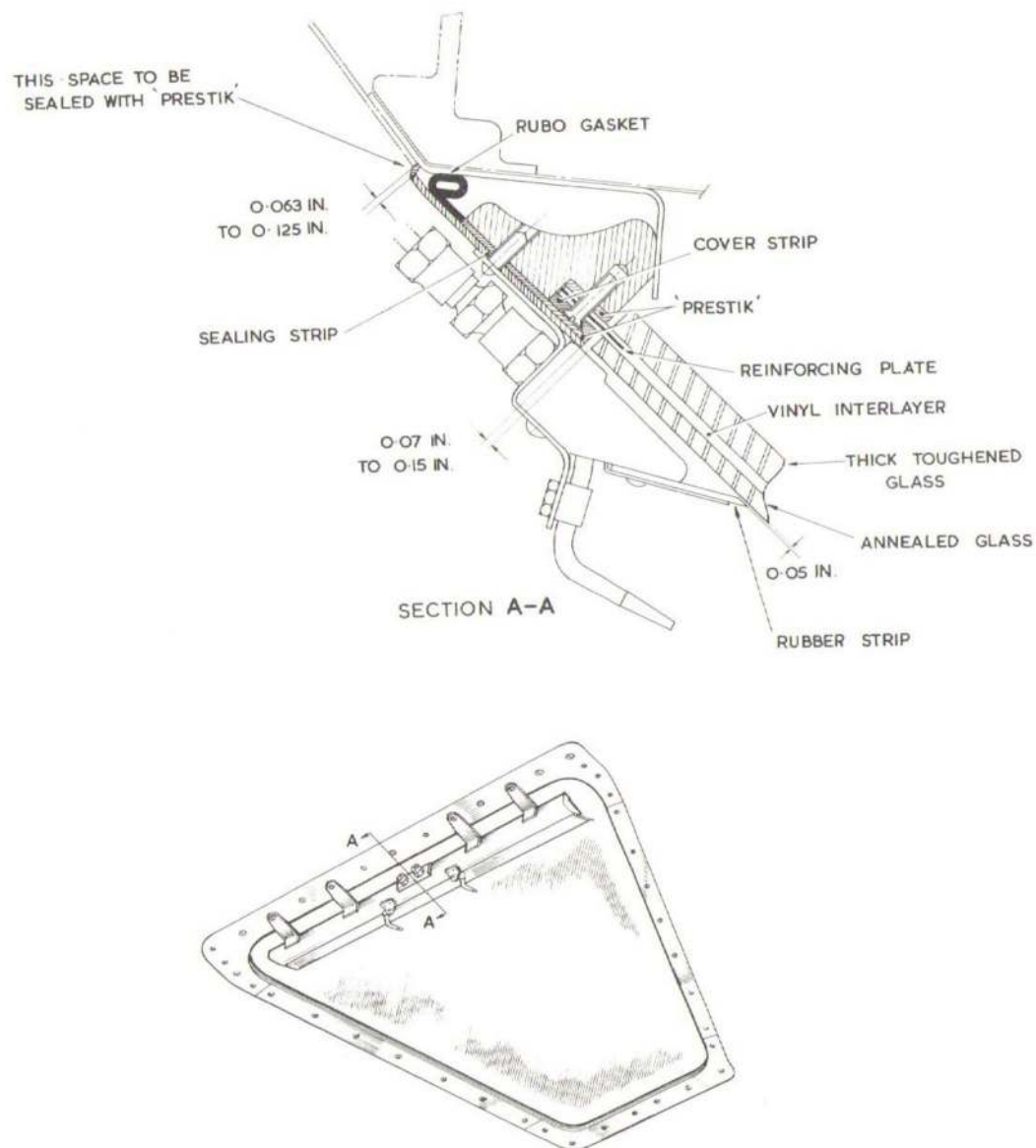

Fig.26. Sealing of air bomber's window

- (7) Fit the sealing strips, taking care not to overtighten the screws and apply one brush coat of Boscolite primer (Ref.No.33H/9429604) to the exposed edges of the Prestik filler.
- (8) Attach the spray assembly to the top of the window (section A-A). Leave a space of 0.05 in. between the rubber strip and the window, and a space of 0.063 in. to 0.125 in. between the top edge of the sealing strip and the aircraft skin. Seal this space with Prestik filler.
- (9) Remove the blanks from the de-icing and fresh water pipes and connect the pipes to the spray assembly.

**Auxiliary window**

35. This is below the main window and is provided with a rubber sealing ring. It is removed and fitted from inside the nose. On the inside of the frame are angle-section retaining strips screwed to anchor nuts. Remove the screws and ease the panel inwards to remove it. Remove the old plastic filler before fitting a new seal and panel. Prestik filler (Ref.No.33H/148) is used to bed the rubber sealing ring on to the external flange of the opening. Treat the exposed Prestik filler with Boscolite primer (Ref. No.33H/9429604).

**REMOVAL OF FRONT GUNNER'S WINDSCREEN**

36. To remove the front gunner's windscreen, proceed as follows:-

- (1) Remove the metal capping strips round the panel on the outside of the frame.
- (2) Remove all the plastic filler from beneath the capping strips.

◀ (3) Remove the screws which attach the securing strip and the Vinyl interlayer to the windscreen casting.

(4) Ease the panel out of the frame.

(5) Remove the rubber sealing strip.

#### FITTING OF FRONT GUNNER'S WINDSCREEN

37. When fitting a replacement windscreen, proceed as follows:-

(1) Thoroughly clean the frame.

#### WARNING...

*It is important that the frame be thoroughly clean, to allow the panel to seat evenly in the frame rebate, otherwise damage may result when fitting the securing strips.*

(2) Fit the rubber sealing strip (Ref.No.26FP/4126) to the frame rebate.

(3) Fit the new panel, complete with securing strip and screws, taking care not to overtighten the screws.

(4) Apply Prestik filler (Ref.No. 33H/148) over the area to be

covered by capping strips.

(5) Fit the capping strips, taking care not to overtighten the screws and apply one brush coat of Boscolite primer (Ref.No.33H/9429604) to the exposed edges of the Prestik filler.

#### REMOVAL OF FRONT GUNNER'S CANOPY

38. To remove the front gunner's canopy, proceed as follows:-

(1) Remove the capping strips round the canopy on the outside of the frame.

(2) Remove the Prestik filler from beneath the capping strips.

(3) Ease the canopy off the frame.

#### FITTING OF FRONT GUNNER'S CANOPY

39. To fit a replacement panel, proceed as follows:-

(1) Thoroughly clean the frame.

(2) Apply Prestik filler (Ref.No. 33H/148) all round the frame rebate.

(3) Fit the canopy in position.

(4) Apply Prestik filler (Ref.No. 33H/148) over the area to be covered by the capping strips.

(5) Fit the capping strips, taking care not to overtighten the screws.

(6) Apply one coat of Boscolite primer (Ref.No.33H/9429604) to the screw heads and the exposed edges of the Prestik filler.

#### OTHER TRANSPARENT PANELS

40. Refer to fig.23 as a general guide to the removal and fitting of all other panels.

#### BOMB DOORS

41. Refer to fig.24 for removal instructions. Re-assembly is the reversal of removal.

#### FRONT SPAR COVERS

42. Refer to fig.25. Re-assembly is a reversal of the removal instructions given. ▶

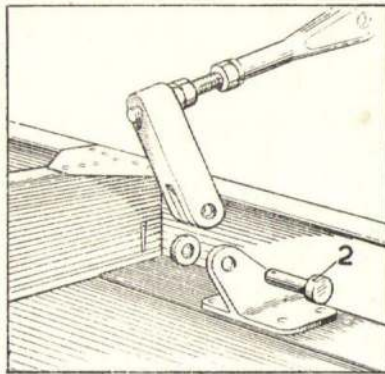

**DETAIL A**  
PORT INBOARD FLAP ONLY

- 1 LOWER FLAPS
- 2 DISCONNECT FLAP INDICATOR TRANSMITTER ASSEMBLY LEVER, PORT INBOARD FLAP ONLY (DETAIL A)
- 3 DISCONNECT FLAP LINKS AT EYEBOLT IN FLAP SPAR (DETAIL B)
- 4 REMOVE BOLTS SECURING FLAPS TO TRAILING EDGE FALSE SPAR (DETAIL C)

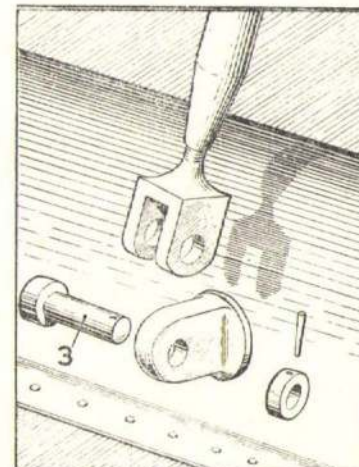
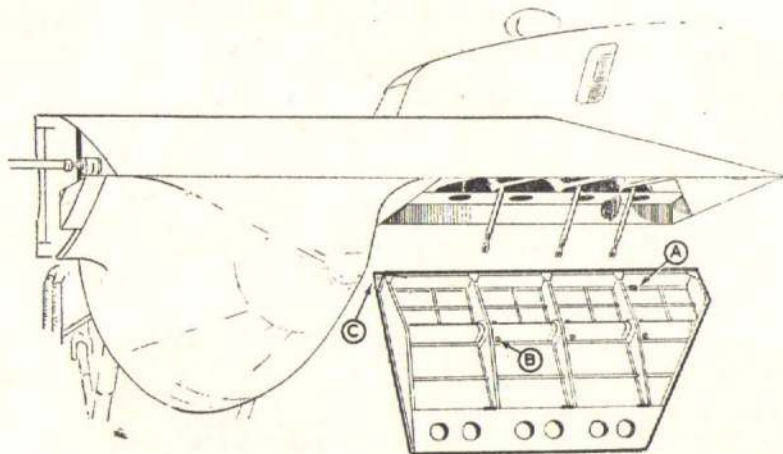
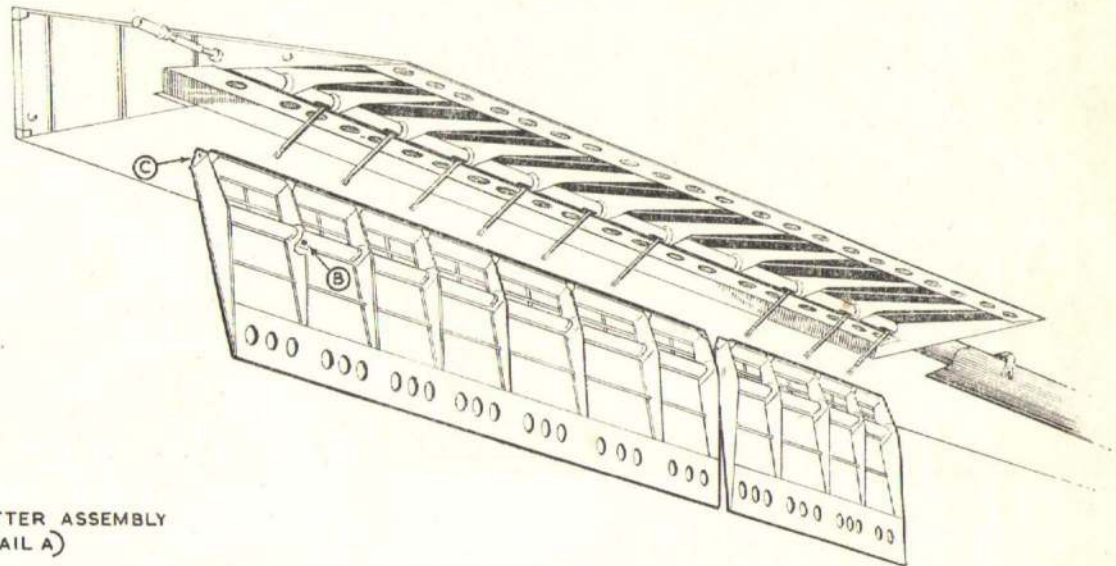

**DETAIL B**

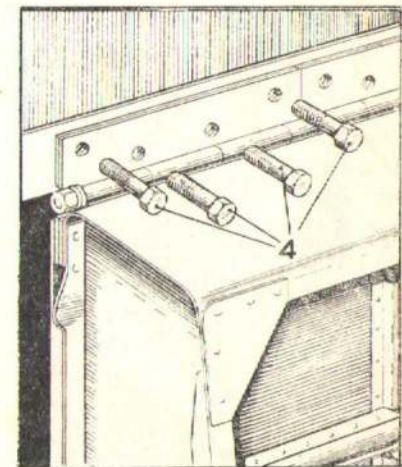

**DETAIL C**

**Fig. 11. Removal of flaps**

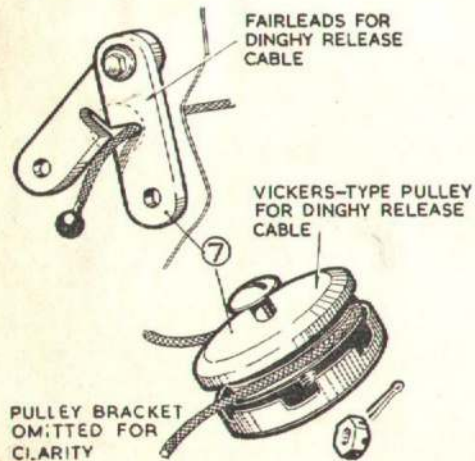
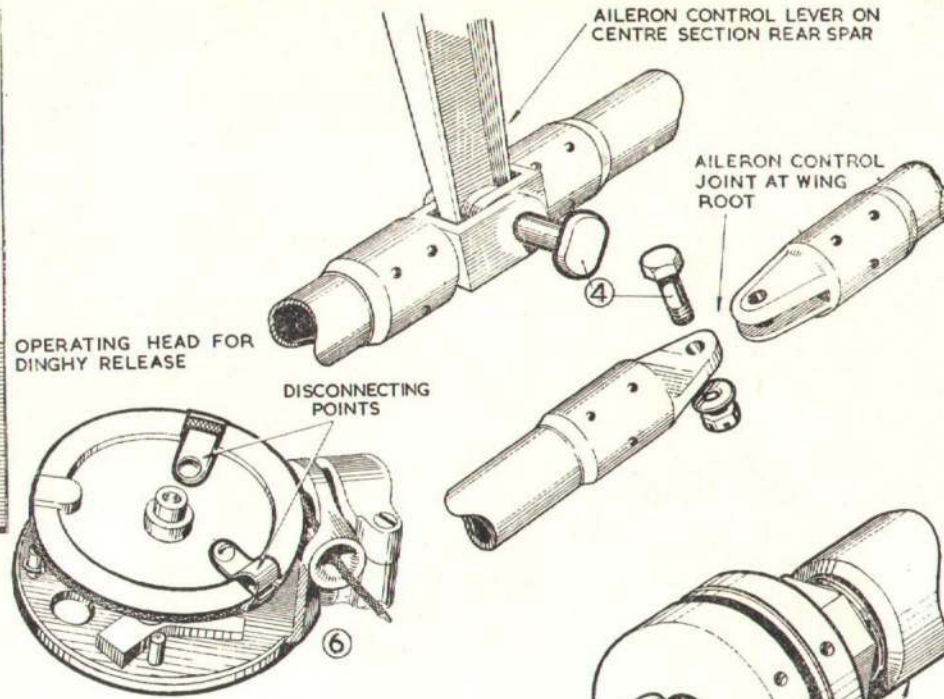
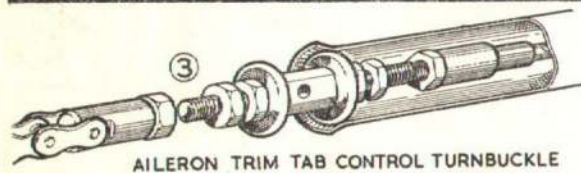
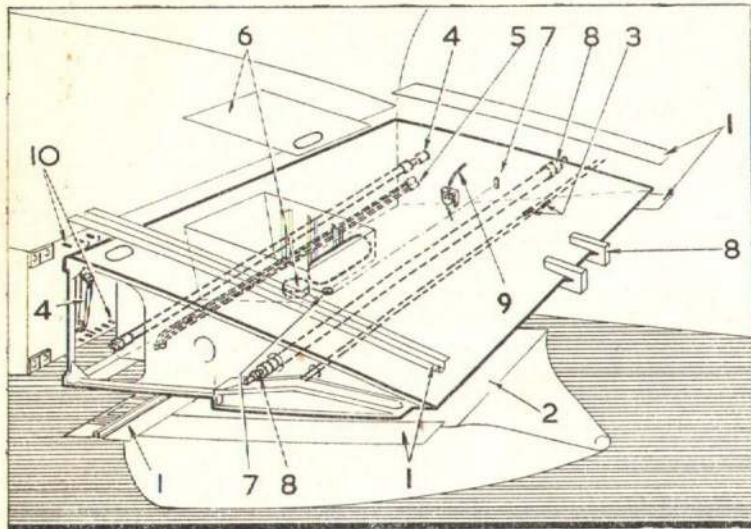

- (1) Remove the assembly panels (Sect. 2, Chap. 4).
- (2) Remove the rear nacelle fairing (Sect. 4, Chap. 1).
- (3) Release the clips and fairleads securing the aileron trim control run guard tubes and disconnect the controls at the turnbuckle joints.
- (4) Disconnect the aileron push-pull rod at the wing root and at the lever on the centre plane rear spar.
- (5) On the port side only, disconnect the fin de-icing fluid pipes at the wing root and at the nacelle.
- (6) Remove the cover over the dinghy stowage (Sect. 3, Chap. 11) and disconnect the dinghy manual release cable at the operating head on the CO<sub>2</sub> bottle.
- (7) Separate the fairleads and dismantle the pulley on the trailing edge rib. Withdraw the dinghy release cable into the fuselage.
- (8) Support the flaps, disconnect the flap-operating tube at the joint inside the fuselage and at the outer end of the trailing edge section. Secure the flaps with locally made clamps.
- (9) Disconnect the electrical cable leading to the flap positional indicator, unclipping and withdrawing the cable (port only).
- (10) Support the trailing edge. Remove the nuts from the attachment studs on the rear spar top and bottom booms. Withdraw from locating dowels.

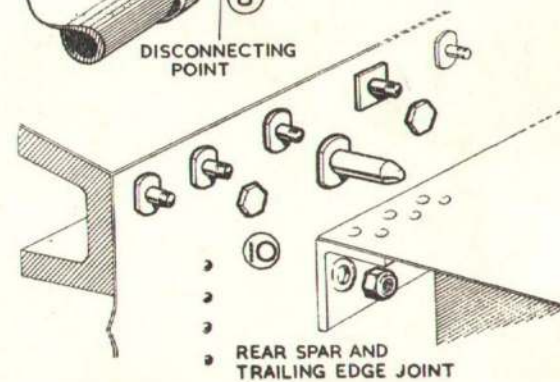

**Fig. 12. Removal of centre plane trailing edge**

This file was downloaded  
from the RTFM Library.

Link: [www.scottbouch.com/rtfm](http://www.scottbouch.com/rtfm)

Please see site for usage terms,  
and more aircraft documents.

