

Chapter 16 FURNISHINGS AND INTERIOR FITMENTS

LIST OF CONTENTS

DESCRIPTION	Para.		Para.		Para.
<i>Introduction</i>	1	<i>Trimming and black-out curtains</i>		<i>Rear observer's station</i>	23
<i>Interior fittings</i>		<i>Trimming...</i>	13	<i>Crew rest bunks</i>	24
<i>Bulkheads and tables</i>	2	<i>Black-out curtains</i>			
<i>Flight engineer's and wireless operator's bulkheads</i>	3	<i>Interior curtains</i>	14		
<i>Front spar covers</i>	5	<i>Curtains at windows</i>	15		
<i>Sonobuoy operator's table</i>	6	<i>Crew seats and cushions</i>			
<i>Radar operator's bulkhead and table</i>	7	<i>Front gunner's and pilots' seats</i> ...	16		
<i>Galley bulkhead and galley</i>	8	<i>Radar and wireless operator's seats</i>	17		
<i>Rear spar covers and crash stations</i>	10	<i>Flight engineer's seat</i>	18		
<i>Bulkhead at former 22</i>	11	<i>Seats at navigator's station</i> ...	19		
<i>Crew's toilet</i>	12	<i>Sonobuoy operator's seat</i>	20		
		<i>Observation seats</i>	21		
		<i>Crew cushions</i>			
		<i>Air bomber's station</i>	22		

SERVICING	
<i>Lubrication</i>	
<i>Crew seats</i>	25
<i>Sliding black-out curtains</i>	26

REMOVAL AND ASSEMBLY	
<i>Crew seats</i>	27
<i>Bulkheads and other fittings</i>	28

LIST OF ILLUSTRATIONS

	Fig.		Fig.
<i>Bulkheads and location of seats</i>	1	<i>Flight engineer's and observer's seats</i>	9
<i>Table at navigators' station</i> ...	2	<i>Navigators' seats</i>	10
<i>Galley</i>	3	<i>Routine navigator's seat (post Mod.674)</i>	11
<i>Galley (post Mod.771)</i>	4	<i>Sonobuoy operator's seat and crash station</i>	12
<i>Hot plate installation (post Mod.771)</i>	5	<i>Air bomber's cushions</i>	13
<i>Rear spar covers and accumulator stowage</i>	6	<i>Crew rest station</i>	14
<i>Front gunner's and pilots' seats</i> ...	7		
<i>Radar and wireless operator's seats</i>	8		

DESCRIPTION

Introduction

1. The contents of this chapter are grouped under three main headings as follows:-

- (1) Interior fittings, comprising all structural fittings which are not part of essential structure and crew amenities.
- (2) Soundproof trimming and black-out curtains.

- (3) Crew's seats and cushions.

INTERIOR FITTINGS

Bulkheads and tables (fig.1)

2. The cabin extends from the nose to former 22 and is divided from the rear part of the fuselage by a bulkhead which incorporates a door. Crew bulkheads are provided at those crew stations where shelves or large panels are necessary.

Flight engineer's and wireless operator's bulkheads

3. Similar in construction, these two bulkheads extend one from each side of the fuselage at former B towards the centre, leaving a gangway into the pilots' station. They are fabricated from light alloy angle, channel-section and sheet. On the forward face of each is a dinghy stowage. The flight engineer's bulkhead has, on its aft face, the flight engineer's main panel and table. This table has a

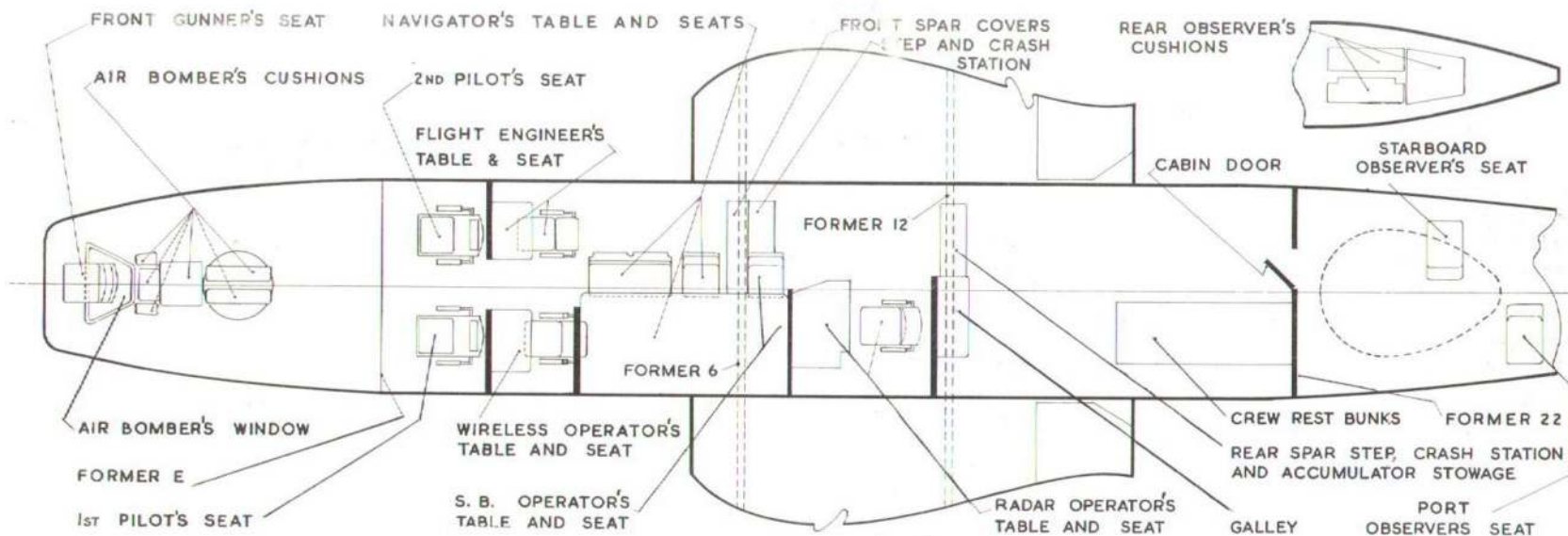

Fig. 1. Bulkheads and location of seats

flap in its upper surface giving access to a stowage in the table. The wireless operator's bulkhead incorporates attachments for the W/T equipment and a table similar to that for the flight engineer.

4. A bulkhead, a little wider than those described in the preceding paragraph, is fitted to the port side of the fuselage at former 2 behind the wireless operator's seat. Aft of this is the navigator's table. The bulkhead plating, consisting of flat sheet forward and corrugated sheet aft, is not continued below the table level, and space is left for the back of the wireless operator's seat to project slightly under the plated structure. The navigator's table extends to the rear spar and consists of a chart stowage with two flaps which constitute the upper surface of the table. Above the table is the navigator's panel and two shelves on which are mounted navigational and radar equipment. Under the table is an inclined footrest.

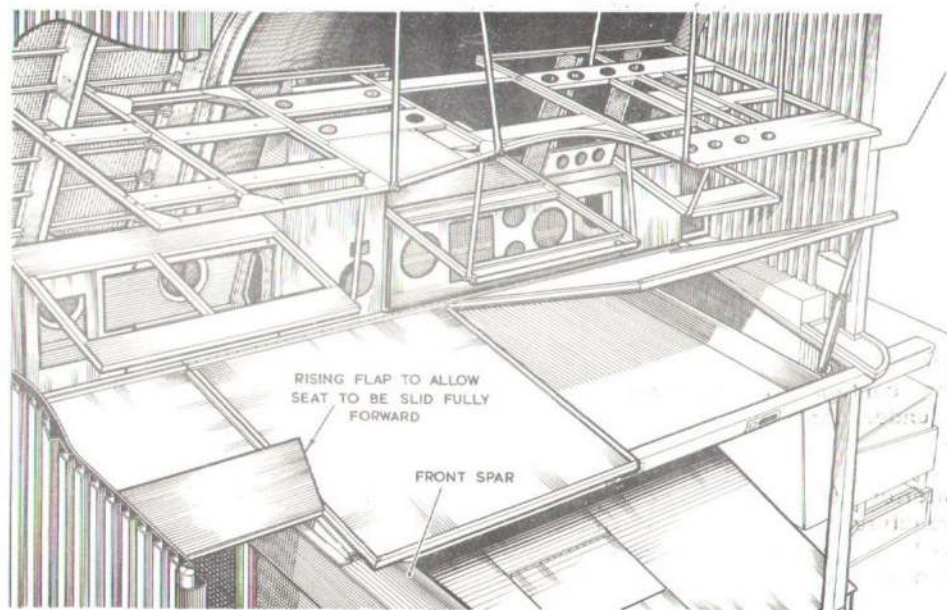

Fig. 2. Table at navigators' station

RESTRICTED

Front spar covers

5. There are six portions comprising the cover which are secured to a framework attached to the spar and to the top cover over the spar stabiliser. To port is a footrest and, on the starboard side, the cover plates are cut away to clear the navigators footrest. These details are shown in the relevant illustrations in Chapter 1 of this section.

Sonobuoy operator's table (fig.2)

6. This is, in effect, a continuation of the navigators table aft of the front spar. It should be noted that the edge of the table is hinged and that it can be folded back to allow for the operators seat to be moved fully forward should the use of the crash stations become necessary.

Radar operator's bulkhead and table

7. This bulkhead, of similar construction to that aft of the wireless operator's seat, is fitted with two deep shelves on its aft face to accommodate the radar equipment and extends from the port side to a little more than half-way across the fuselage. The table is fitted with a hinged flap which, when raised, increases its area.

Galley bulkhead and galley

8. Aft of the radar operator's seat is another bulkhead of the same width as that aft of the wireless operator's seat. On the aft face of this bulkhead is the galley. The associated water system supplying water to the galley is described in Chapter 14 of this section. The kitchen unit with its sink, cupboards and controls is shown in fig.3. It will be noted that this unit is not mounted with its forward face parallel to the bulkhead, but raked forward to maintain efficient drainage of the sink when the aircraft is in flight. A refuse bin is secured to the floor just forward of the turret pedestal.

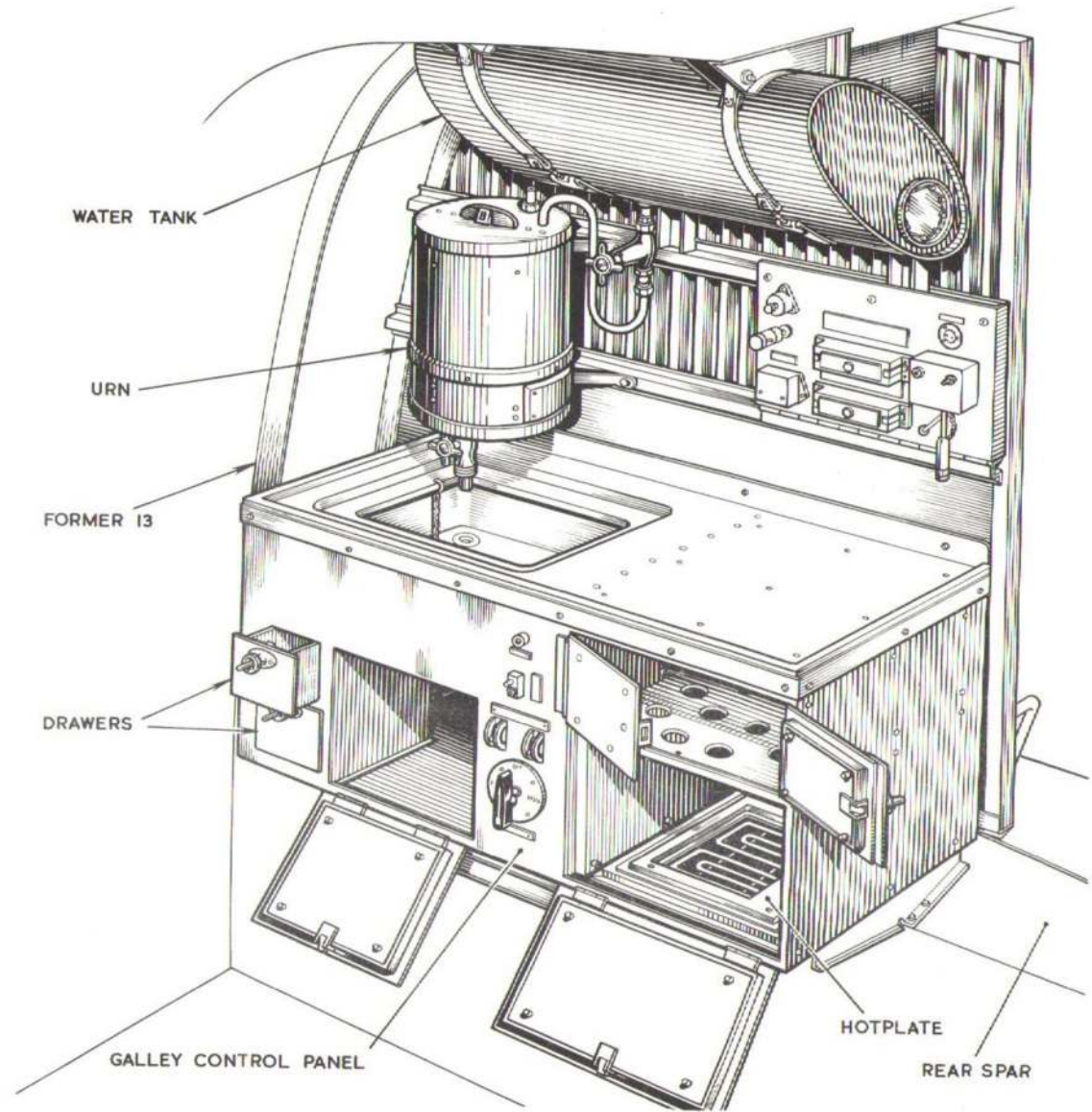

Fig.3. Galley

9. The galley, on aircraft with Mod.771 embodied, is illustrated in fig.4. An additional hot plate and its associated controls, installed by Mod.771, is mounted on top of an equipment stowage fitted over the port flap operating rod. The hot plate cupboard is fitted with a fume extractor pipe which terminates at a rearward facing vent on the port side of the aircraft. Three trays are stowed at the rear of the of the equipment stowage. A refuse bin is secured to the floor on the port side of the aircraft directly to the rear of the galley. The additional hot plate cupboard and controls are illustrated in fig.5.

Rear spar covers and crash stations (fig.6)

10. Forward of the rear spar are two plates with tubular frames between the inboard edge of the galley bulkhead and the starboard fuselage wall. The frames are hinged at their lower edges and secured to a cover over the spar stabiliser by quick-release pins. These provide back rests for the two forward facing crash stations and behind them is the stowage for the aircraft batteries.

Bulkhead at former 22

11. This bulkhead separates the cabin from the aft portion of the fuselage and has a forward opening door slightly to starboard of the fuselage centre-line. Both door and bulkhead consist basically of corrugated sheet and plate riveted together. Angle-section brackets secure the assembly to former 22 and the wider port side has transverse top-hat section stiffeners riveted to its aft face. On the forward face, at the port side of the door, is a narrow vertical plate riveted to a lipped-channel section post which carries door hinges and is secured to the corrugated face by long bolts and distance pieces. A foot step is incorporated in this plate to give access to the upper rest bunk. Low down on the door is a louvred ventilator opening.

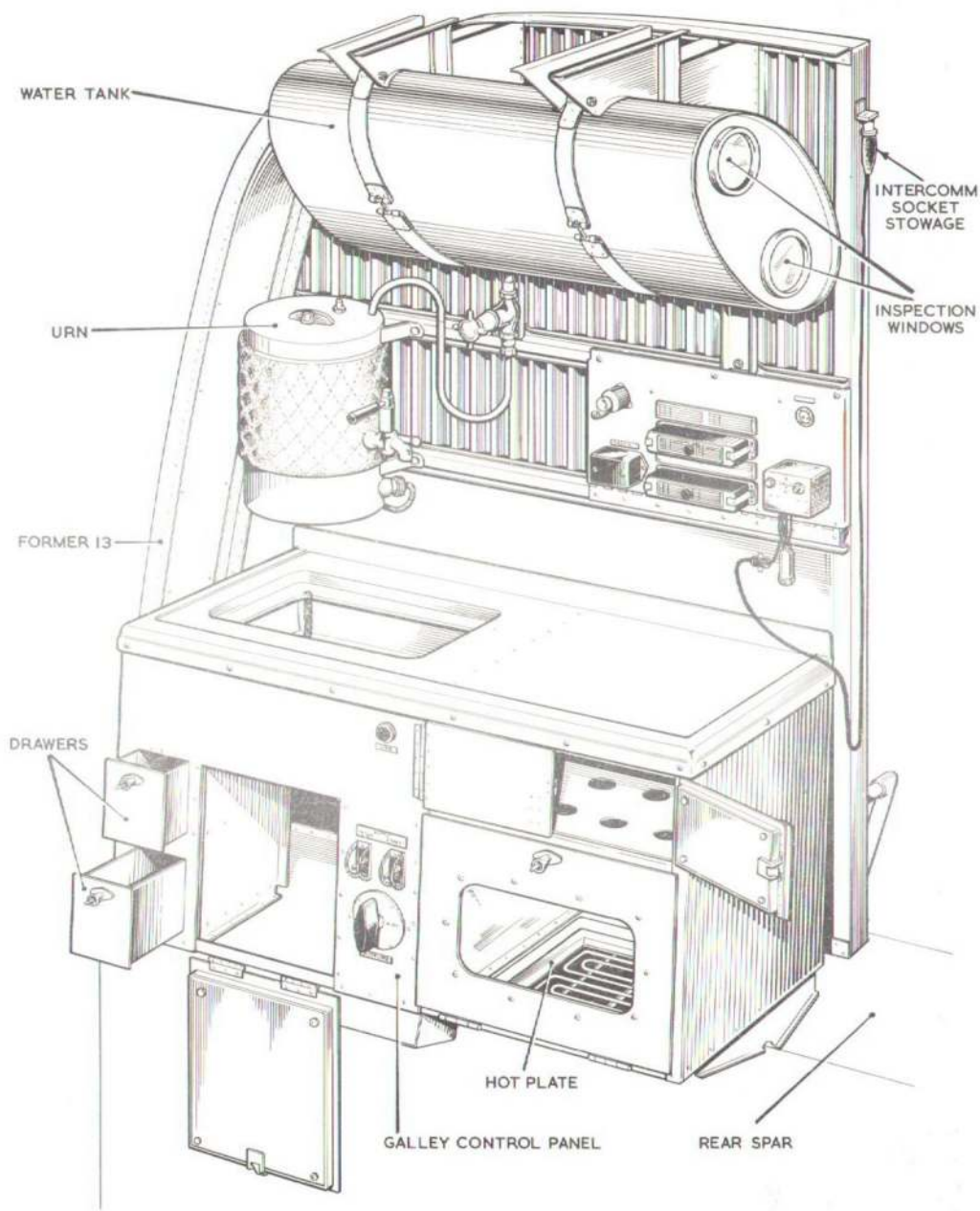

Fig.4. Galley (post Mod.771)

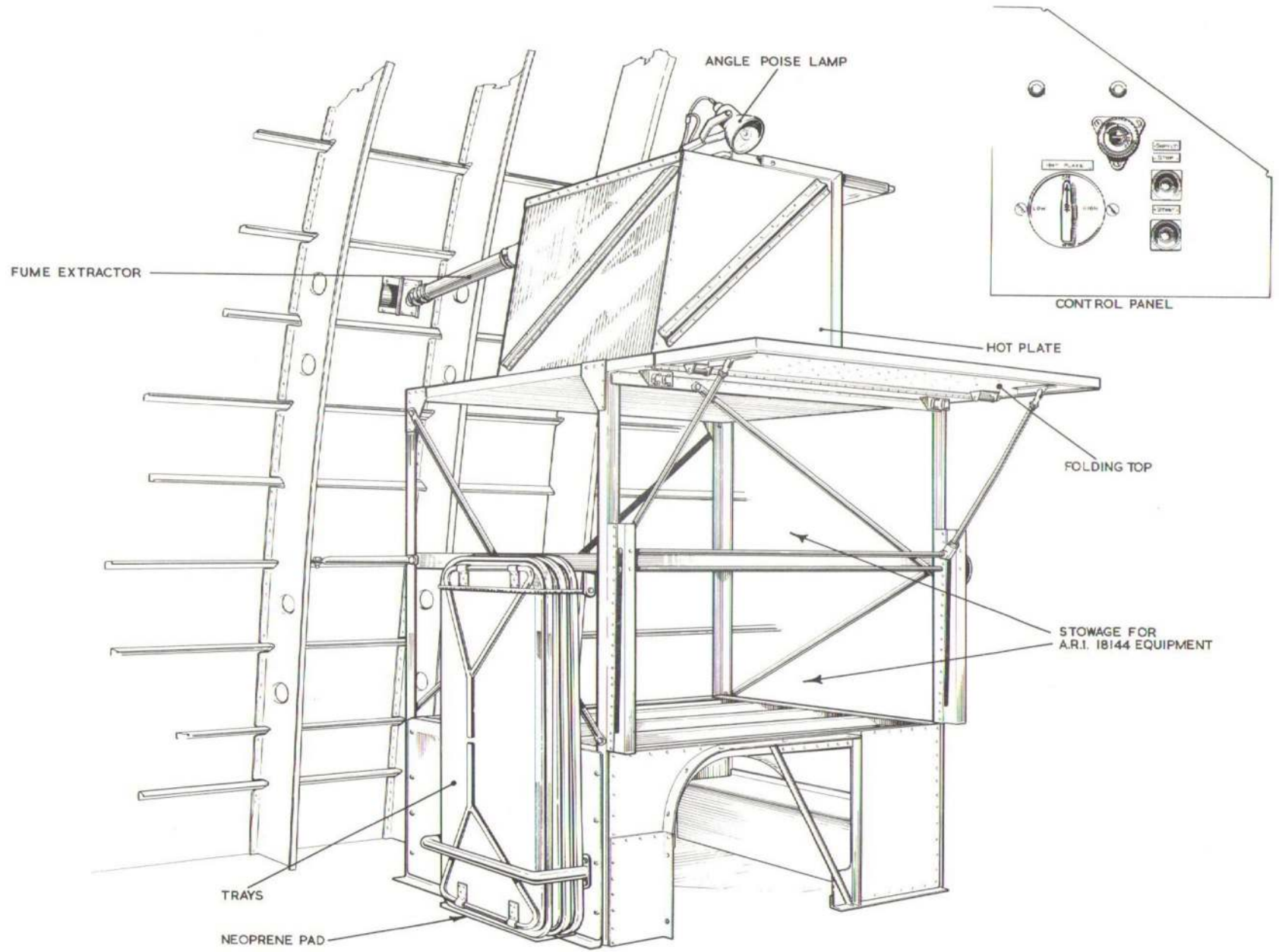

Fig.5. Hot plate installation {post Mod.771}

RESTRICTED

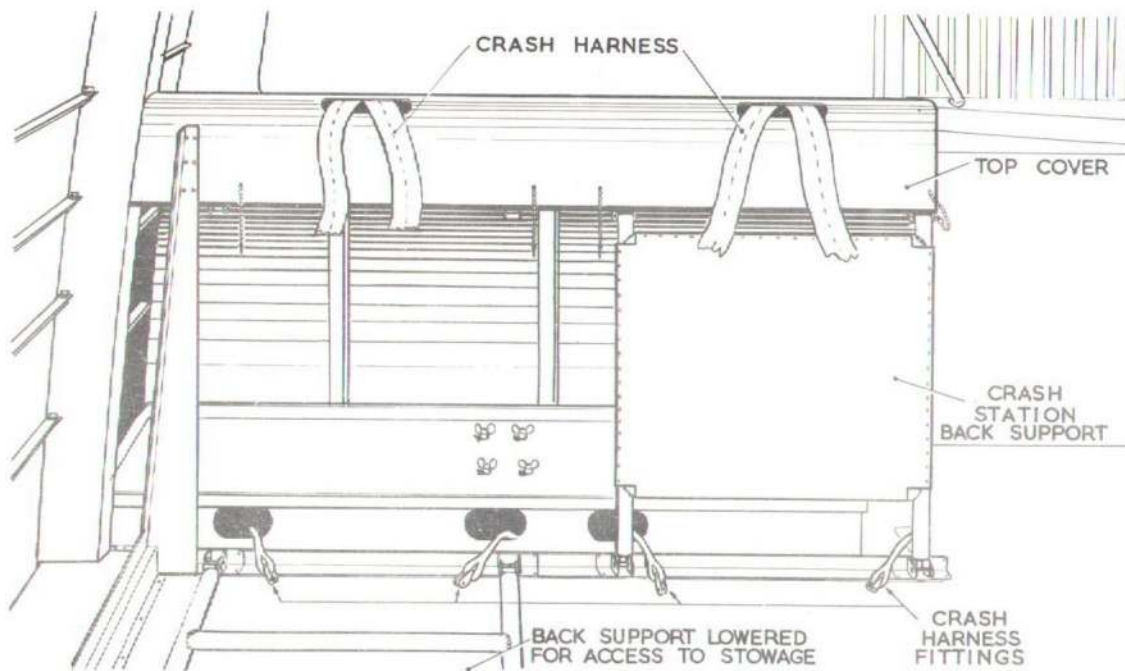

Fig.6. Rear spar covers and accumulator stowage

Crew's toilet

12. Between formers 32 and 33, on the port side, is mounted an Elsan installation incorporating an anti-spillage tray. A toilet roll holder is fitted to the opposite side of the fuselage, above the installation. Beside the Elsan is a relief tube connected to a rectangular container mounted in the floor.

TRIMMING AND BLACK-OUT CURTAINS

Trimming

13. Between former E, at the forward

end of the front centre section, and former 22, the roof and sides of the fuselage, other than where panels or windows are fitted, are covered with detachable trimming panels. The trimming is built up of various materials in the following order:-

- (1) Glass cloth, next to the structure.
- (2) Two half-inch layers of fibreglass, each of which is septum covered on one surface.

NOTE . . .

Septum is a fire resisting material resembling cellophane.

- (3) Another layer of glass cloth is attached to an outer covering of Vynide by quilted stitching.
- (4) This dual covering is then attached to (1) and (2) by bending it over the edges of these layers and stitching all round to form a hem.

Black-out curtains

Interior curtains

14. These are made from fireproof fabric and are arranged as follows:-

- (1) A sliding curtain is fitted between the flight engineer's and wireless operator's bulkheads. When not drawn, it is secured by straps to the edge of the wireless operator's bulkhead.
- (2) Behind the flight engineer's seat is a fixed curtain and the space left between this and the bulkhead at the forward end of the navigator's table can be blacked-out by a sliding curtain.
- (3) A sliding curtain is provided between the starboard side of the fuselage and the radar operator's bulkhead at former 8.
- (4) Another sliding curtain is fitted to cover the space between the the radar operator's bulkhead and the galley bulkhead.
- (5) A sliding curtain is provided at formers 31 and 32 to screen the Elsan installation.
- (6) At former 48, at the forward end of the transparent tail fairing, two

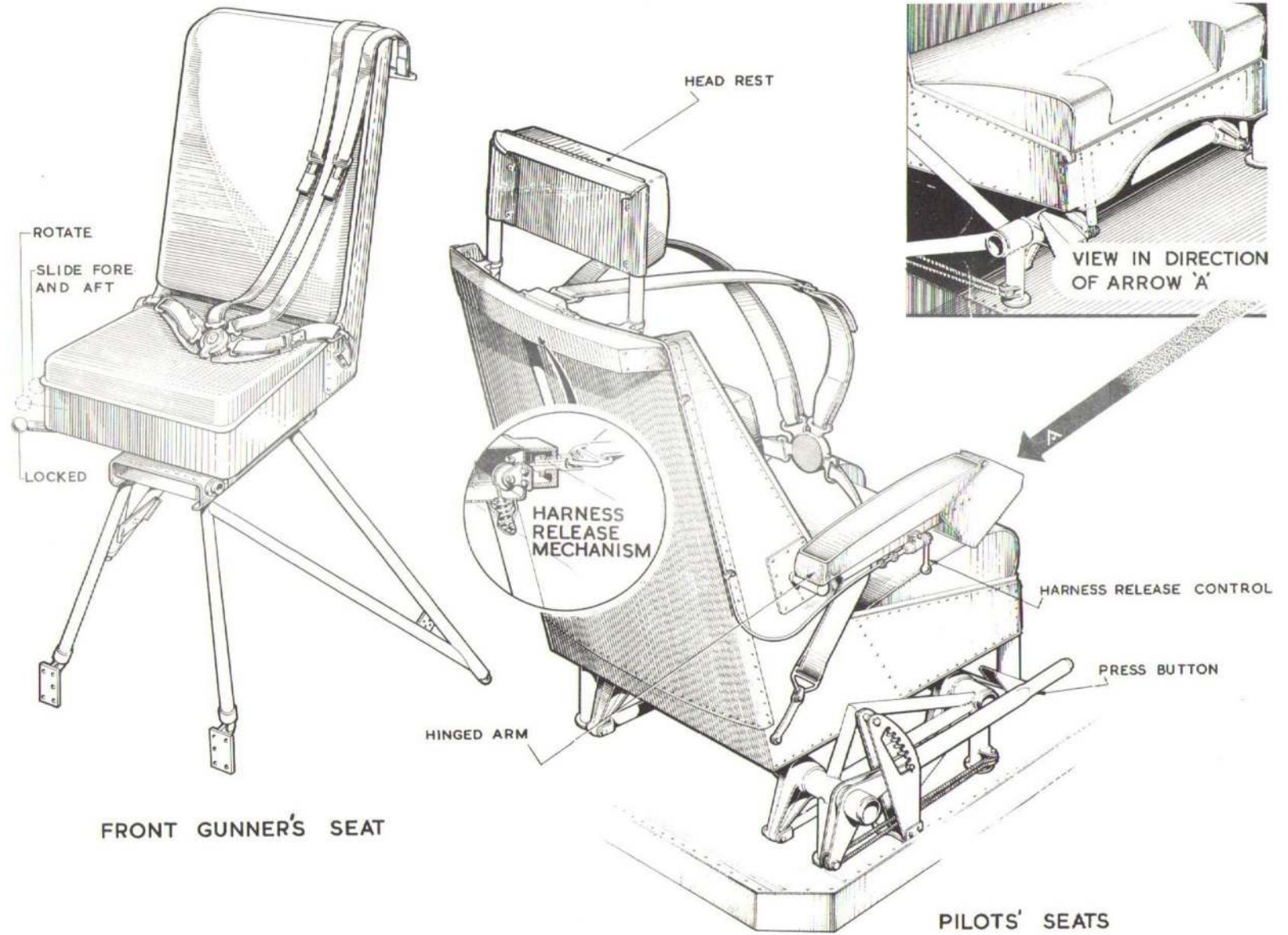

Fig. 7. Front gunner's and pilots' seats
RESTRICTED

CREW SEATS AND CUSHIONS

Front gunner's and pilot's seats (fig.7)

16. The illustration shows the first pilot's seat, the second pilot's seat is identical, with the exception that the controls are on the left-hand side. The raising and lowering mechanism is similar to that fitted to the navigator's rising seat. The gunner's seat can be moved fore and aft, or rotated, for the convenience of the occupant.

Radar and wireless operator's seats (fig.8)

17. Similar to the pilot's seats, these

are secured to two mounting channels, instead of an adjustable mounting, by welded tubular members bolted between the upper portions of the channel webs. A tie-rod extends from an eye-bolt aft of the wireless operator's seat to a lug bolted to the floor beam at former 3. This tie-rod strengthens the mounting to enable the chair to be used as a crash station. A map stowage is secured to the port side of the radar operator's seat.

Flight engineer's seat (fig.9)

18. A swivelling seat is mounted on a pedestal which is bolted to the floor. A

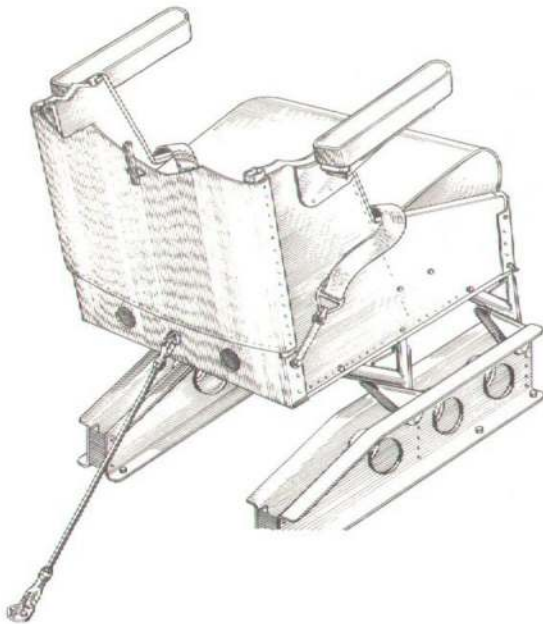

Fig.8. Radar and wireless operator's seats.

curtains are secured to the sides and top of the former. When in position, the two curtains are joined by a zip-fastener which is pulled down to close them. When the black-out is not required, the fastener is pulled right up and the two halves are secured to the side of the former by retaining straps.

Curtains at windows

15. Similar fabric to that used for the interior curtains is used for all windows with the exception of the observer's windows in the rear section of the aircraft.

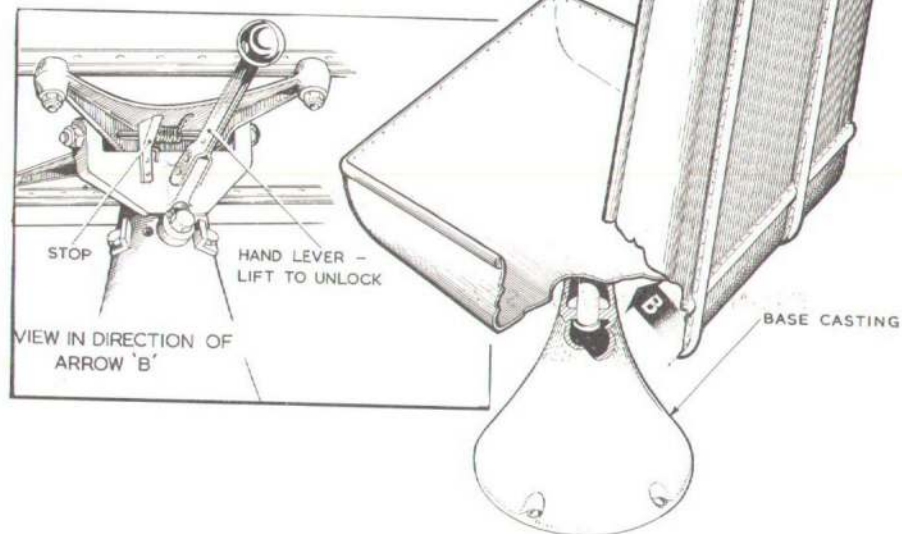

Fig.9. Flight engineer's and observer's seats

RESTRICTED

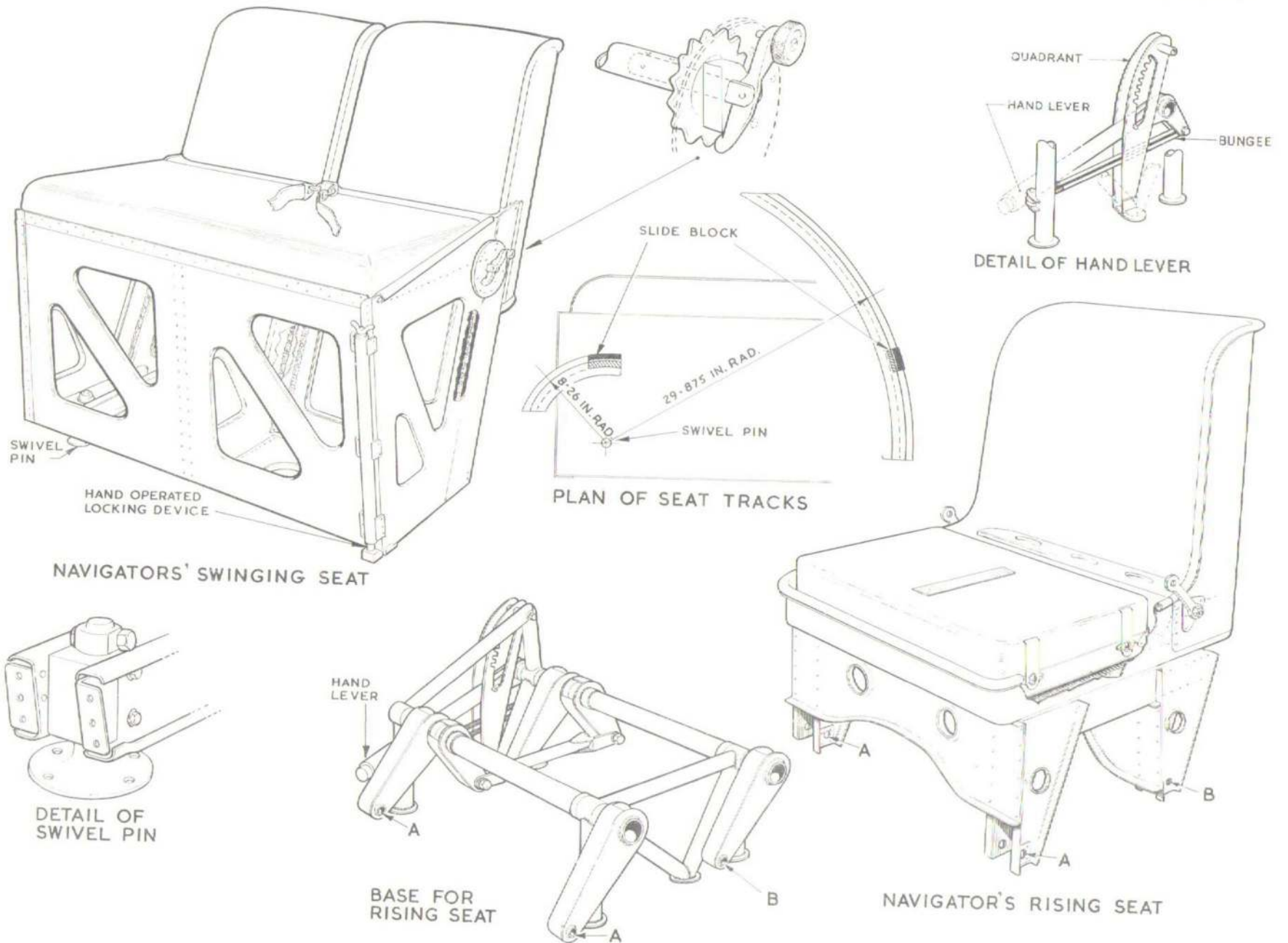

Fig. 10. Navigators' seats
RESTRICTED

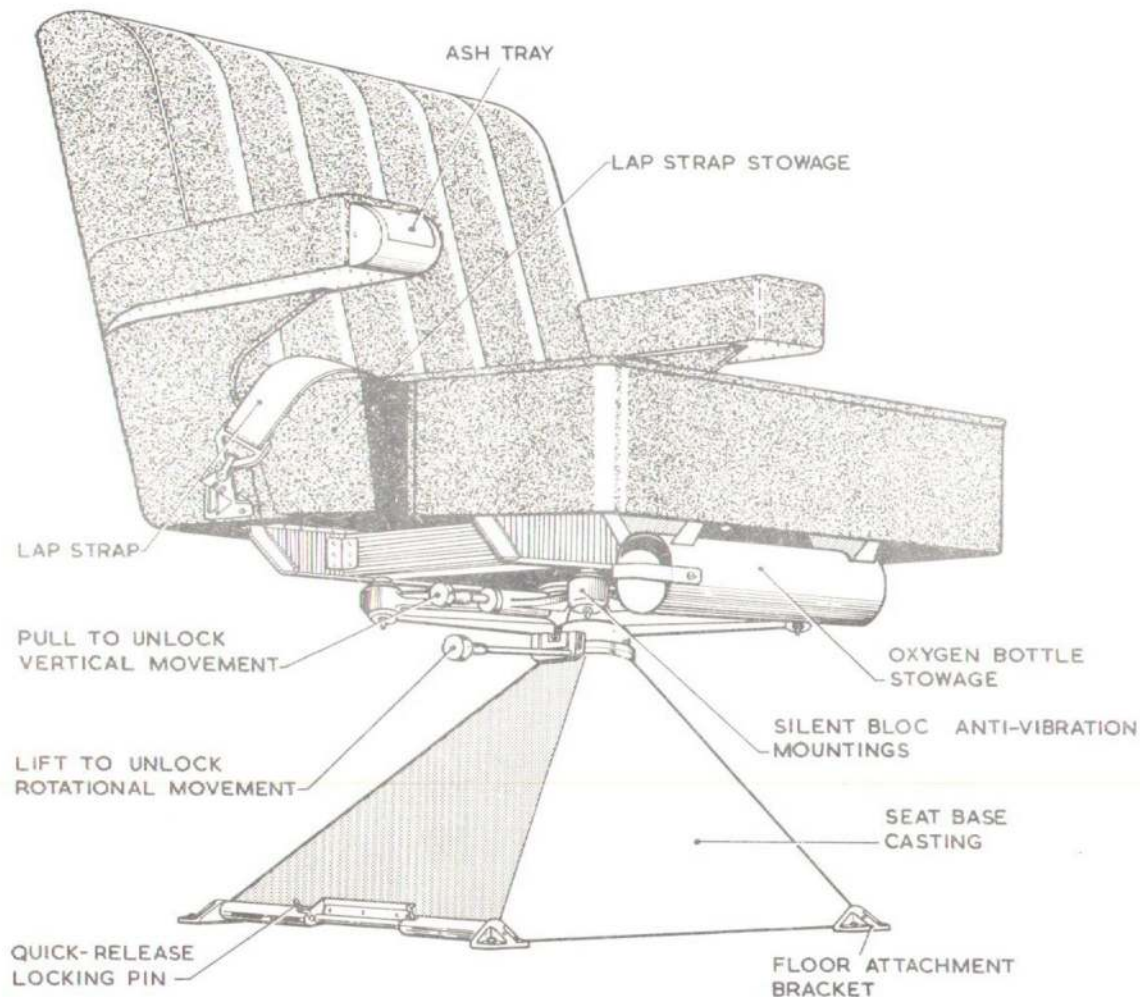

Fig.11. Routine navigator's seat (post Mod.674)

lever under the port side of the seat lifts up to allow the seat to be turned sufficiently to enable the engineer to leave easily. Releasing the lever enables a lock to retain the seat either facing forward or partially turned to port.

Seats at navigator's station (fig.10)

19. Three seats are provided as follows:-

- (1) Forward is a double seat for two crew members seated side by side. It consists of a base which provides two seats and has two separate backs which can be raised or lowered independently by a rotating handle which normally locks itself, but is freed by pressing it inwards. The construction and operation is shown in fig.10 which also illustrates the swivelling point rolling blocks and runners provided to enable the seat to be swung clear of the bomb slip which it covers in the floor. It is necessary to lower the seat backs to get into the seats comfortably. A guard, to prevent inadvertent operation of the seat backs, is provided for each seat-operating handle. When Mod.674 is embodied the navigators swinging seat is replaced by a single swivelling seat illustrated in fig.11.
- (2) A single seat with a fixed back fitted between the double seat and the front spar in the intermediate centre section of the aircraft, is occupied by the second navigator. It can be raised or lowered by a lever controlled mechanism similar to those for the pilots' seats (fig.7), but the range of movement is greater to allow entry to the seat and to facilitate use of a sextant at the astrodome overhead.

Sonobuoy operator's seat (fig.12)

20. Aft of the front spar, a fourth seat faces to port and slides transversely on rails fitted to the step and crash station aft of the front spar. The seat is of similar appearance to the pilots' seats and, to enable the crash stations to be prepared for use when necessary, is moved towards the operator's table. This arrangement is shown in fig.12.

Observation seats (fig.9)

21. Two seats are located in the fuselage rear centre section as follows:-

- (1) One on the port side between formers 27 and 28 opposite the port observation window.
- (2) One on the starboard side between formers 25 and 26 opposite the starboard observation window.

These seats are of the same pattern as that for the flight engineer.

CREW CUSHIONS**Air bomber's station (fig.13)**

22. In the nose, aft of the bomb-sight, body and elbow cushions are provided for the air bomber, who, when occupying the station, is in a prone position. These cushions are arranged as follows:-

- (1) A body cushion, approximately 19 ins. wide, extending between formers J and K.
- (2) Two leg cushions, approximately 8¾ in. wide, extend over the escape hatch upper doors between formers C and J. One cushion is attached to each door. and when the doors

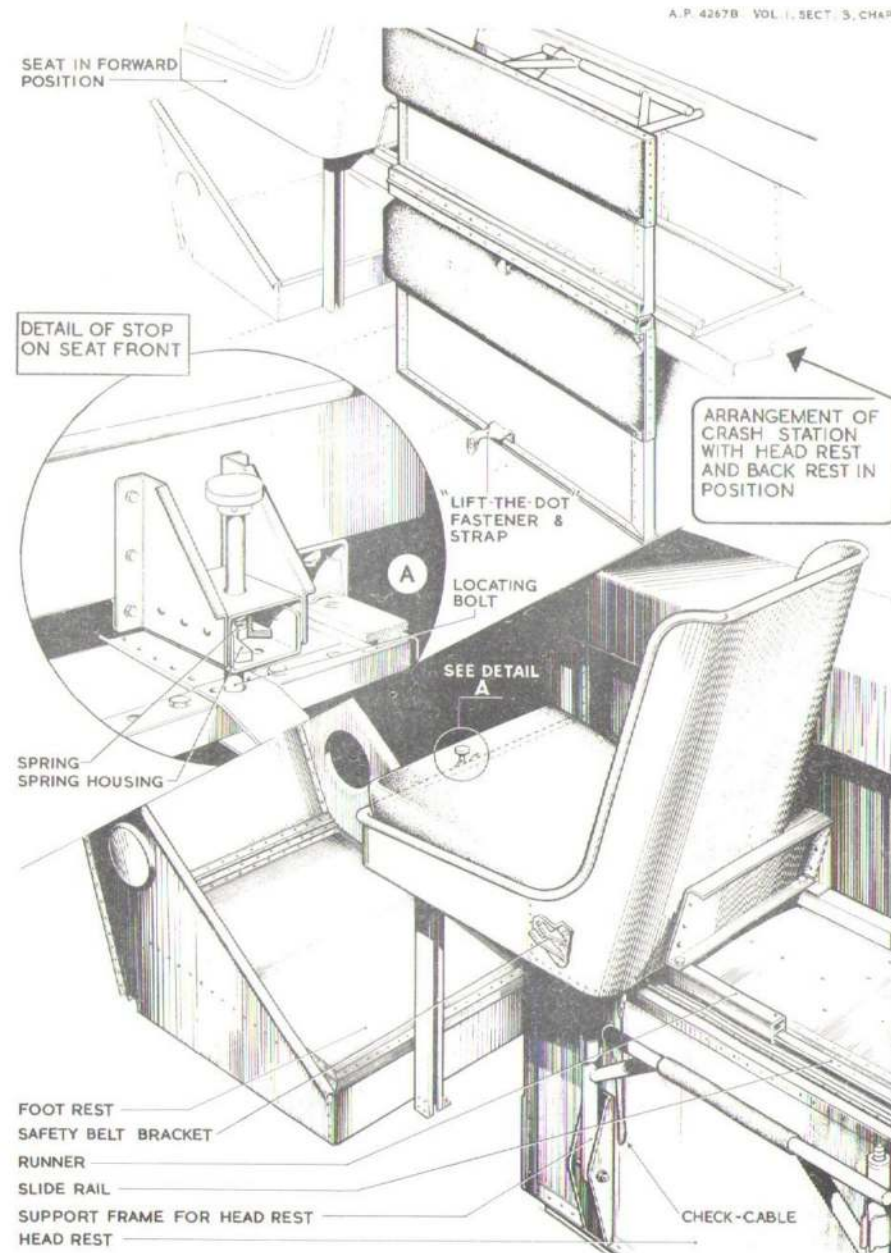

Fig.12. Sonobuoy operator's seat and crash station

RESTRICTED

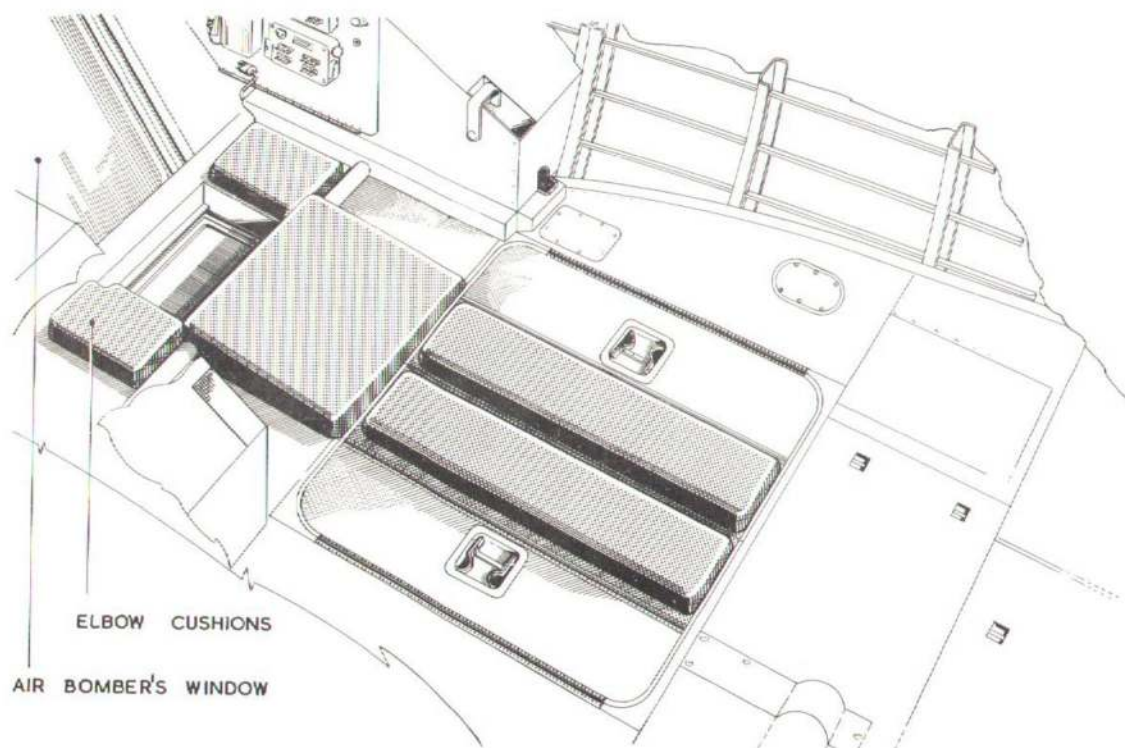

Fig.13. Air bomber's cushions

are closed the cushions are close together.

- (3) Two elbow cushions, one to port and one to starboard, of the space between the body and the air bombers window.

All these cushions are attached to the aircraft floor by press-stud fasteners.

Rear observer's station

23. At the aft end of the fuselage between formers 45 and 48, is a set of three cushions similar to those in the nose, for the use of a crew member when operating the astro-compass which is mounted at former 48. Two cushions are fitted, one on each side of the aft camera compartment doors, and, between these and former 44, is a single cushion shaped

to fit the taper of the fuselage. These cushions are attached by 'lift-the-dot' fasteners and are illustrated in Section 1, Chapter 2.

Crew rest bunks (fig.14)

24. Two bunks are provided on the port side of the rear centre section, between formers 17 and 22. Two canvas covered, light-alloy tubular frames are hinged, one above the other, to formers 18 and 21. When the bunks are not in use, they can be stowed flat against the side of the fuselage. The upper bunk has folding tie-rods, secured to the fuselage roof, which fold inwards when the bunk is stowed. The lower bunk rests on folding legs. Details of stowage straps, brackets and attachments are shown in fig.14.

SERVICING

LUBRICATION

Crew seats

25. Lubricate periodically all moving parts of the seats - arm rests and adjustment gear - using a minimum quantity of oil, OM-150.

Sliding black-out curtains

26. The curtain runners are liable to jam if the rails are lubricated, owing to dust and dirt being collected by any oil applied to them. If the runners are found to jam, they should be removed from the rails and the curtains, washed in kerosine and allowed to drain and dry before refitting. The curtain rails should be cleaned with a cloth moistened with kerosine.

REMOVAL AND ASSEMBLY

CREW SEATS

27. When a seat or seats need to be removed, the procedure is self-evident and no specific sequence of operations need be observed.

BULKHEADS AND OTHER FITTINGS

28. These are secured directly by bolts or by bolted clips.

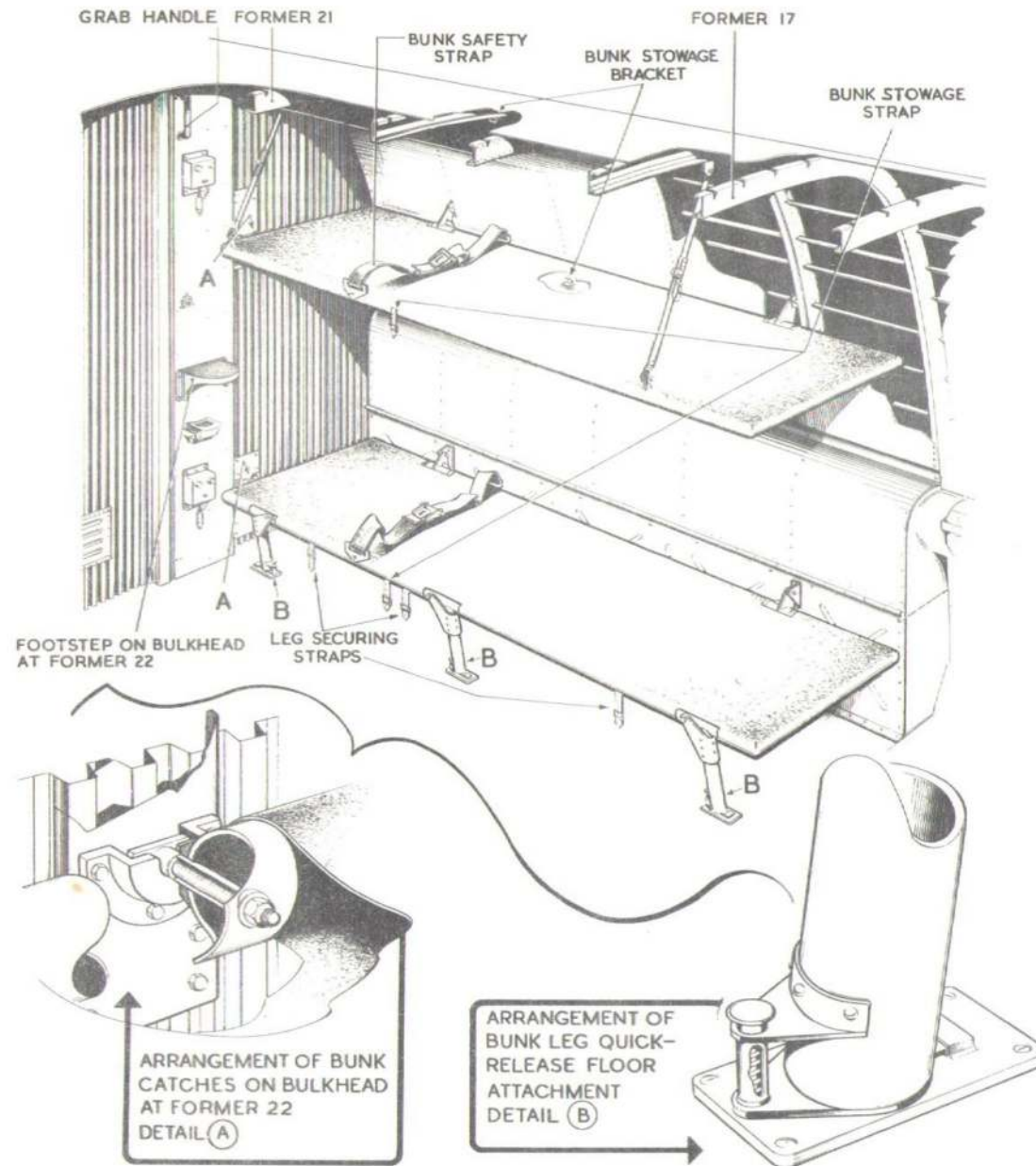

Fig.14. Crew rest station



This file was downloaded
from the RTFM Library.

Link: www.scottbouch.com/rtfm

Please see site for usage terms,
and more aircraft documents.

