

Chapter 3.—TAIL UNIT

LIST OF CONTENTS

	Para.		Para.
DESCRIPTION			
Introduction	1	Elevators	17
Tail plane		Trim tabs	19
Construction	3	Balance tabs	20
Spars	5	SERVICING	
Main ribs	6	Rigging	21
Fins	9	Lubrication	22
Rib numbering	11	REMOVAL AND ASSEMBLY	
Rudders	12	Fins and rudders	23
Trim tabs	15	Fins assembly	24
Spring tabs	16	Elevators and tail plane	25
		Tail plane assembly	26

TABLE

	Table
Fin and rudder rib numbers	1

LIST OF ILLUSTRATIONS

	Fig.		Fig.
Tail plane	1	Mounting of fin to tail plane	5
Fin and rudder	2	Removal of elevator	6
Elevator	3	Removal of tail plane	7
Removal of fin and rudder	4		

DESCRIPTION

INTRODUCTION

1. The tail unit consists of a twin spar tail plane with a fin and rudder at each extremity. A diagram showing former and rib positions is contained in Sect. 2, Chap. 4. Constructed in two halves which are bolted together inside the fuselage, the tail plane is attached by bolts to formers 37 and 41. The fins are bolted to the ends of the tail plane spars.

2. Each of the four main control surfaces (elevators and rudders) has a trim tab.

The elevators each have, in addition, a balance tab and the rudders a spring tab.

TAIL PLANE

Construction (fig. 1)

3. Each half of the tail plane, which is constructed in light alloy, has a front and rear spar to which nose and centre ribs are attached by vertical angle strips riveted to the spar webs. To the aft face of the rear spar are attached three elevator hinge brackets, each of which is shrouded by a

sealing box (A fig. 1). The inboard bracket on each side gives the datum. Luminum washers are fitted as necessary under the bases of the brackets to align the hinges. Shoe brackets are attached by counter-sunk screws (detail B) to the top and bottom of each spar at the inboard end. The corners where these brackets are fitted are reinforced with riveted gusset plates.

4. The assembly is secured to the fuselage by bolts which pass through holes in the spars either side of the central joint inboard of each No. 1 rib.

SPARS

5. Two extruded angle-section booms, which taper outboard, are riveted to a web which also tapers outboard. Vertical angle strips are riveted to both faces of the front spar and to the forward face of the rear spar to provide attachments for the ribs.

MAIN RIBS

6. These are chiefly flanged pressings with flanged lightening holes and vertical top-hat-section stiffeners between the lightening holes. The outside flanges of the webs are cut away to take the stringers. Ribs 2, 8 and 12 are reinforced on the outboard face at their rear ends to provide extra stiffness where the elevator hinges are attached to the rear spar. This stiffening is obtained by lengths of lipped channel section which are riveted to the rib webs, and inset by an amount sufficient to allow the stringers to clear them. The stiffeners are bolted at their rear ends to attachment forks which are, in turn, bolted to the rear spar booms by the bolts which carry the elevator hinges. In addition, vertical rib stiffeners, which are secured to the lengths of channel section by gusset plates, are provided.

7. In each half of the tail plane, rib No. 1 (at which point the tail plane passes through the fuselage skin) is constructed of a top and

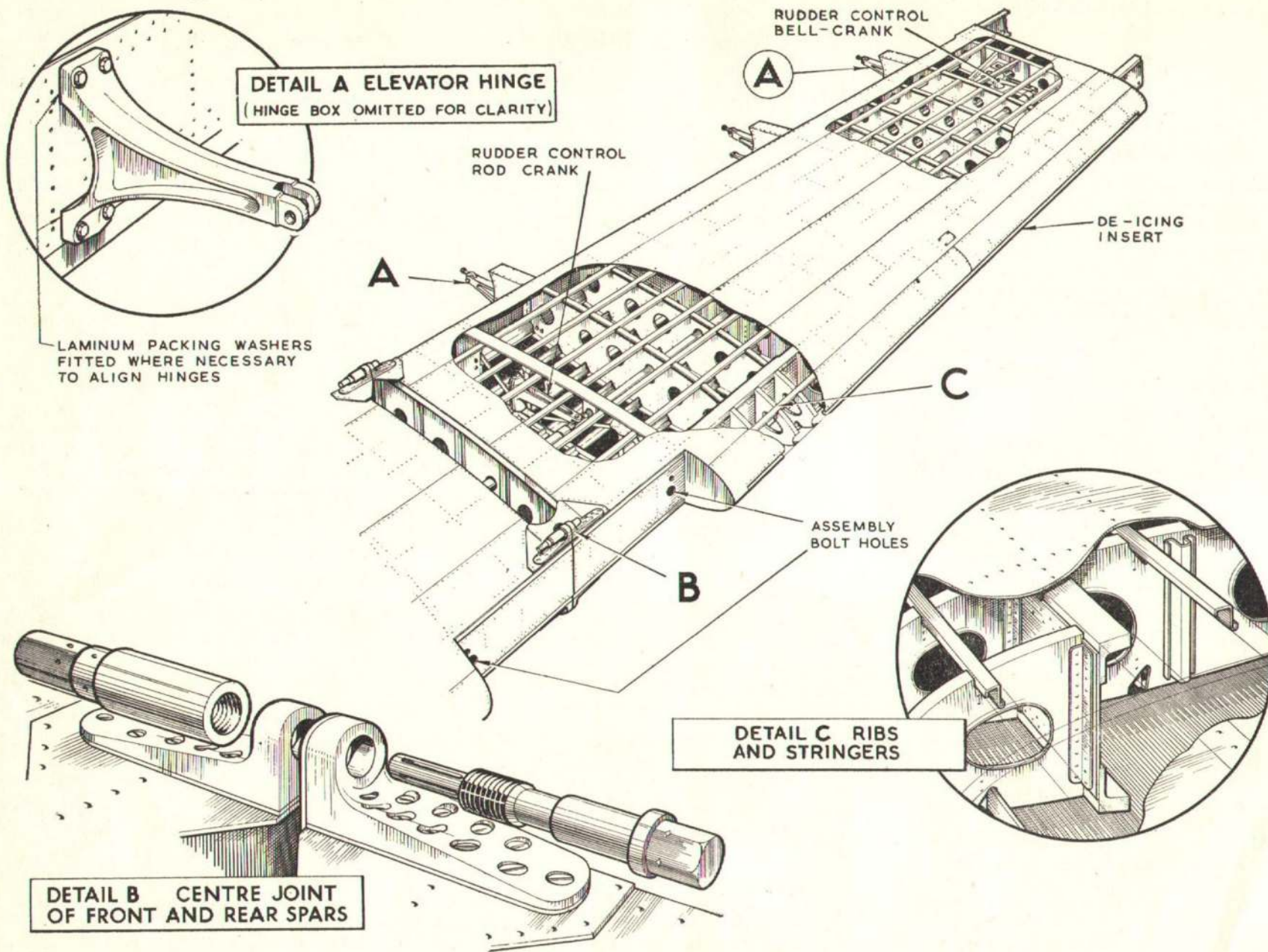

Fig. 1. Tail plane

RESTRICTED

bottom boom of extruded T-section with two vertical and three diagonal struts of angle-section. At the ends are web plates with stiffening flanges. All joints in the framework are made with riveted gusset plates. Rib B, inboard of rib. 1, is of normal construction; the innermost rib A is of sheet reinforced by lipped channel-section booms and vertical top-hat-section struts. At rib 1 (port half only) and between ribs 12 and 13 (both halves), are mountings for the rudder control rod cranks which are shown in fig. 1.

8. The top and bottom flanges of the ribs are tied by transverse stringers of lipped L-section let into the ribs and secured by riveted brackets (fig. 1). Plating of light-alloy sheet is riveted to the ribs and stringers, and a porous metal de-icing insert (fig. 1) is fitted along the whole length of the leading edge.

FINS (fig. 2)

9. These are each built up on two fin posts with an intermediate post running the full height of the fin. The posts are built up from web plates riveted to angle-section booms and are tapered to form the aerofoil shape. The leading edge carries a single de-icing insert and is lapped over the plating. All of the rib sections are flanged pressings with lightening holes. Strips of flexible rubberised fabric are riveted to the fin post and screwed to the shrouding between the rudder horns to blank off any airflow between that part of the rudder and the fin.

10. The fin front and rear posts are bolted to the projecting ends of the tail plane spar (fig. 1). A bossed plate, bolted to the forward face of the rear spar, carries the screwed shaft and sprocket which operate the rudder trim tab. Three double ribs between the intermediate and rear fin posts provide reinforcement for the rudder hinge brackets bolted to the aft face of the rear post (opposite detail A, fig. 2) to which a bolt and stop assembly is also bolted. The bolt engages with a bush held in the stop-and-locking

assembly on the rudder post (detail A, fig. 2) when the pilot's locking control lever is pulled back (Chap. 4). On the port side of each fin, at rib 7 counting from the top, is a bracket to which is connected the forward end of the tab control rod. The de-icing pipe shown in fig. 2 is clipped at ribs 2, 4, 6 and 8.

Rib numbering

11. The system of rib numbering applicable to the fins (and to the rudders described later) is based on the vertical height of each rib in inches above (A) or below (B) the fin and rudder datum line as shown in the following table. The rib positions are given with the corresponding identification number:—

TABLE I
Fin and rudder rib numbers

Rib		Rib No.
1		A.102 in.
2		A.90 in.
3	} double	{ A.77 in.
3		
4		A.66 in.
5		A.54 in.
6		A.42 in.
7	} double	{ A.30 in.
7		
8		A.18 in.
9		A.6 in.
Datum		Datum
10		B.6 in.
11	} double	{ B.16 in.
11		
12		B.28.6 in.
13		B.42 in.

RUDDERS (fig. 2)

12. The rudders are of similar construction to the fins and are attached to the latter by three ball bearing hinges. The rudder is the horn balance type with a full length rudder post and thirteen horizontal ribs (refer to the preceding paragraph for the system of rib identification). Ribs 3, 7 and 11 are

double, providing reinforcement where the hinge brackets are bolted to the forward face of the rudder post. Ribs 1 to 3 (upper), 12 and 13 are in two parts extending forward into the horns and aft to the trailing edge. Ribs 3 (lower) to 11 (upper) extend aft only from the rudder post and ribs 6 to 11 end at the trim tab post. Ribs 4 to 11 have no corresponding ribs forward of the rudder post, the leading edge between ribs 3 and 11 being formed by eight shroud ribs of semi-circular shape. In the horns, forward of the rudder post, are vertical intercostals between the ribs and the end sweep to give additional strength, and in the leading edge of each horn are the main mass-balance weights, bolted to a web riveted between the inner and outer side of the leading-edge plating. A mass-balance tube (detail C, fig. 2) is bolted to the rear face of the web in each horn and lead and wooden plugs are put into the tube to give the correct rudder balance. A cover plate, secured by screws, retains the plugs in each tube.

13. On the forward face of the rudder post, a rudder stop and locking assembly is secured by bolts (detail A, fig. 2). Additional reinforcement, to relieve the concentrated load imposed on this assembly by wind pressure when the rudder is locked, is provided by two flanged plates riveted to two angle brackets held by the assembly attachment bolts. The semi-circular stop-and-locking member embodies a locking-bolt bush and two stop blocks which are illustrated in the detail.

14. Aft of the rudder post, a stringer on each side runs vertically from top to bottom. Further aft, two more stringers run from rib 1 to 13, where they are each extended by a tapered intercostal. On the trim tab post are four tab hinges at rib 6, rib 8, rib 9 and rib 11 (detail B, fig. 2). The trim tab control rod is connected at its forward end to the trim tab operating assembly on the fin hinge post. It passes aft inside the rudder and emerges outboard level with the hinge between ribs 8 and 9, the opening being faired over.

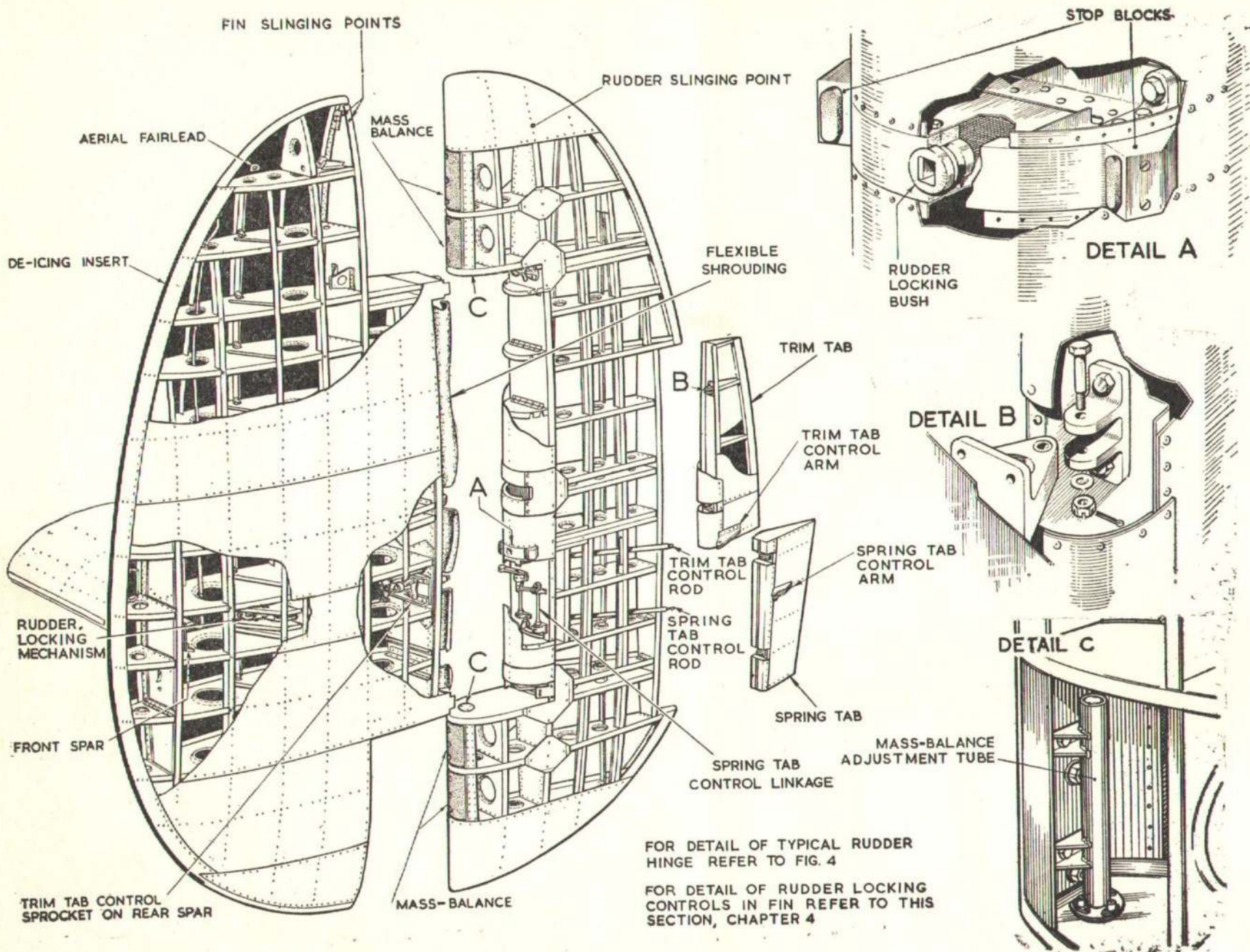

Fig. 2. Fin and rudder

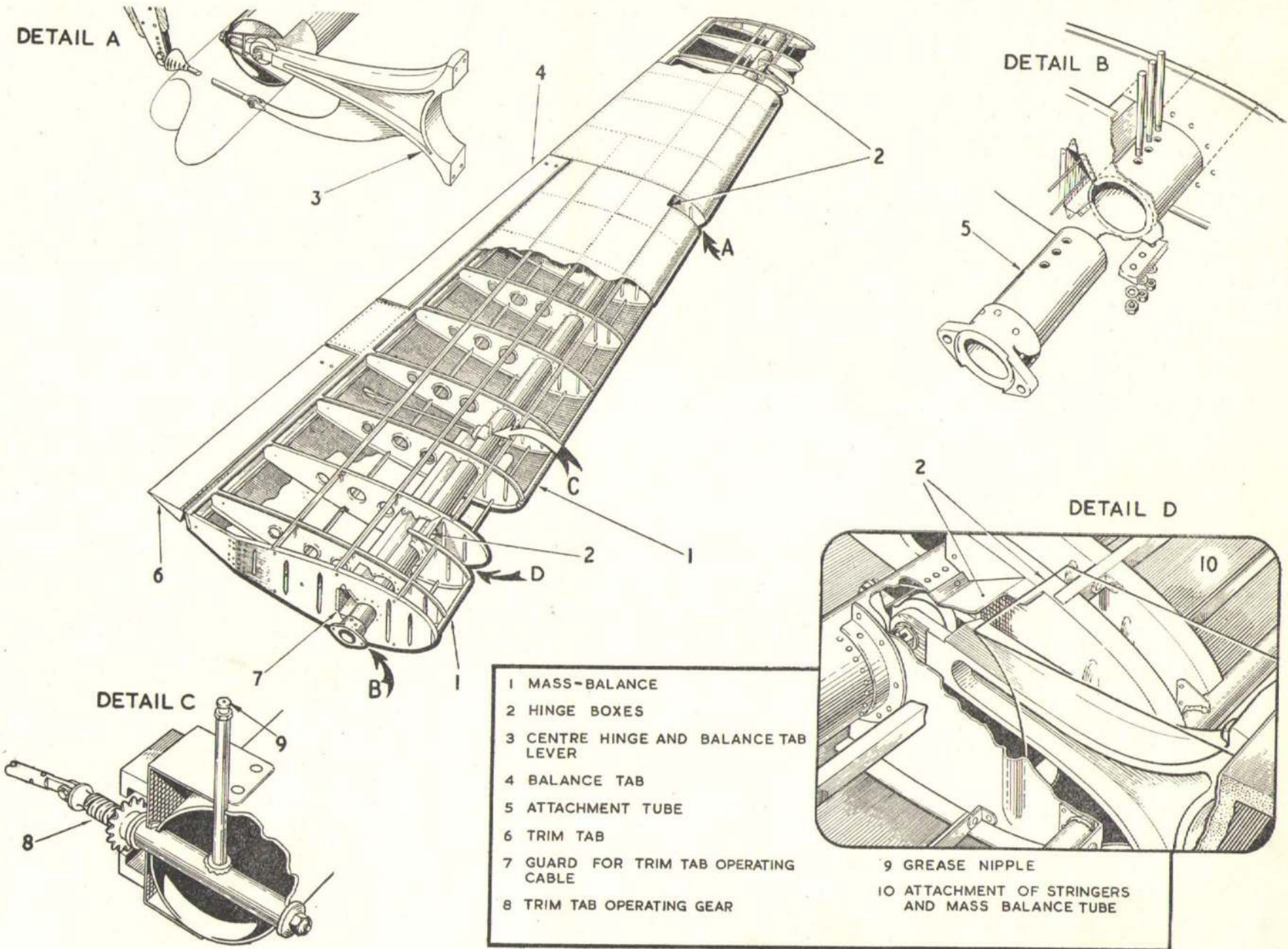

Fig. 3. Elevators

Trim tabs

15. These are the upper tabs on the rudders. They are each built up on a pressed flange spar with triangular ribs riveted to its aft face. The rear points of these ribs are joined together by the trailing-edge U-section and the whole is covered with light-alloy plating and has a rounded cover to form a leading edge. This is cut away to give access to the two hinge brackets (*detail B, fig. 2*). On the outboard face of the tab is riveted the trim tab control arm.

Spring tabs

16. These are fitted below each trim tab and are hinged to the lower two brackets on each rudder tab post. Construction is similar to that of the trim tabs. Each has a control arm on its outer side which is secured to the rear end of its operating rod. The forward end of the rod is connected to the lever at the lower end of the spring tab torsion bar described and illustrated in Chap. 4.

ELEVATORS (*fig. 3*)

17. The spars are made from steel tube with welded blanking plate at each outboard end. They are of uniform diameter throughout their length and are cut away on their forward face at three hinge positions. The square holes thus formed are filled in with welded boxes (*detail D, fig. 3*). A reinforcement plate is riveted inside each spar at each opening before the box is welded in position. At the inboard end is a light-alloy bush and inside is fitted the end of an attachment tube (*item 5*) which is secured by three tapered pins having threaded ends. Three sets of nuts and lock-washers in conjunction with a bearing plate secure the pins. At the inboard end of the attachment tube is a riveted flange which is bolted to a similar flange on a torque tube connecting the two elevators together inside the fuselage. To the rear of the inboard end of each spar is a guard tube (*item 7*) which forms a guard for the trim tab operating cable. The sprocket and operating gear for the tab are shown in detail C of fig. 3.

18. The ribs (through which the spar passes) are flanged and have three lightening holes

aft of the spar. The nose of ribs 1, 2 and 3 is cut away to accommodate a mass-balance tube which has an open end accessible from the inboard hinge recess in the leading edge. The open end of this tube is fitted with a sealing plug retained by a set screw in the leading edge. Lead and wood plugs are inserted into the tube to give the correct mass-balance. The main mass-balance weight is provided by steel rods, one fitted to the noses of ribs 4 to 9 and another to the noses of ribs 10 to 13. There are three stringers let into both upper and lower flanges of the ribs and secured by riveted brackets. The aft ends of ribs 1 to 9 are squared and riveted to a channel-section rear member which carries the hinges for the trim and balance tabs. Between the tabs is fitted a short trailing-edge section; outboard of the balance tabs, the ribs continue aft to the trailing edge and are secured by rivets to a U-section trailing-edge member. The elevators are covered with light-alloy sheet.

Trim tabs (*fig. 3*)

19. Each tab is located at the inboard end of its respective elevator, and is operated by a push-pull rod which is connected to an arm riveted to its undersurface and to the fork-end of the operating gear screwed rod (*detail C, fig. 3*). The tabs are constructed of light-alloy, having triangular ribs secured forward to a channel spar and aft to a trailing-edge member and are covered with light-alloy sheet.

Balance tabs (*fig. 3*)

20. These are similar in construction to the trim tabs. Each is operated by a rod connected to an arm on the underside of the tab and, at its forward end, to a static lever on the bottom face of the elevator centre hinge (*detail A, fig. 3*).

SERVICING

RIGGING

21. Rigging data and instructions for the tail plane and fins are given in Sect. 2, Chap. 4, and those for the elevators and rudders together with their associated tabs are in Chap. 4 of this section.

LUBRICATION

22. All lubrication of the tail plane, fins, rudders and elevators, excepting the elevator and rudder hinges is confined to the flying and control locking systems, and is described in Chap. 4 of this section. The elevator and rudder hinge bearings are sealed ball bearings which are packed with Grease, Low Temperature XG-275, Stores Ref. 34B/222 on assembly and do not require periodical lubrication.

REMOVAL AND ASSEMBLY

Note . . .

Where, in any key to an illustration covering a removal procedure, an operation key number is not bracketed, the operation is not shown on the associated illustration. If the operation is illustrated elsewhere, a reference is quoted.

KEY TO FIG 4 (REMOVAL OF RUDDER)

- (1) REMOVE THE BOLTS SECURING THE EDGE OF THE FABRIC TO THE SHROUD ON THE RUDDER POST.
- (2) REMOVE THE ACCESS PANELS FROM THE SHROUD ON THE RUDDER POST.
- (3) REMOVE THE SCREWS SECURING THE HINGE OUTBOARD COVER PLATES AND REMOVE THE PLATES.
- (4) DISCONNECT THE RUDDER-OPERATING ROD FROM THE RUDDER OPERATING ARM BY REMOVING THE BOLT.
- (5) DISCONNECT THE TRIM TAB OPERATING ROD FROM THE SCREW JACK BY REMOVING THE SPLIT PIN, WASHER AND CONNECTING PIN FROM THE UNIVERSAL JOINT.
- (6) SUPPORT THE RUDDER USING A SLING (*Sect. 2, Chap. 4*), REMOVE THE NUTS, BOLTS AND BONDING CLIPS FROM THE HINGES AND WITHDRAW THE RUDDER FROM THE HINGES.

Note . . .

On aircraft embodying Mod. 408, the hinge bolts are wire locked.

REMOVAL OF FIN

- (7) ATTACH THE SLING (STORES REF. 26FP/315) TO THE SLINGING POINT, SHOWN IN FIG. 2 AT THE TOP OF THE FIN POST (*Sect. 2, Chap. 4*).
- (8) DISCONNECT THE AERIAL BY REMOVING THE WEAK LINK AT THE REAR INSULATOR.
- (9) REMOVE THE PANEL ON THE OUTBOARD FACE OF THE FIN AT THE TAIL PLANE LEVEL.
- (10) DISCONNECT THE DE-ICING SYSTEM PIPE AT ITS UNION.
- (11) RELEASE THE TRIM TAB CONTROL CABLES AT THE TURNBUCKLES THROUGH THE ACCESS DOOR IN THE UPPER SURFACE OF THE TAIL PLANE.
- (12) REMOVE THE ATTACHMENT BOLTS AND REMOVE THE RUDDER TRIM TAB CONTROL GEAR.
- (13) DISCONNECT THE OUTER END OF THE RUDDER LOCKING SYSTEM PUSH-PULL ROD IN THE TAIL PLANE FROM THE BELL-CRANK IN THE FIN.
- (14) REMOVE THE BOLTS SECURING THE FIN TO THE FRONT SPAR OF THE TAIL PLANE.
- (15) REMOVE THE BOLTS SECURING THE FIN TO THE REAR SPAR OF THE TAIL PLANE AND SWING THE FIN CLEAR OF THE SPARS BEFORE LOWERING.

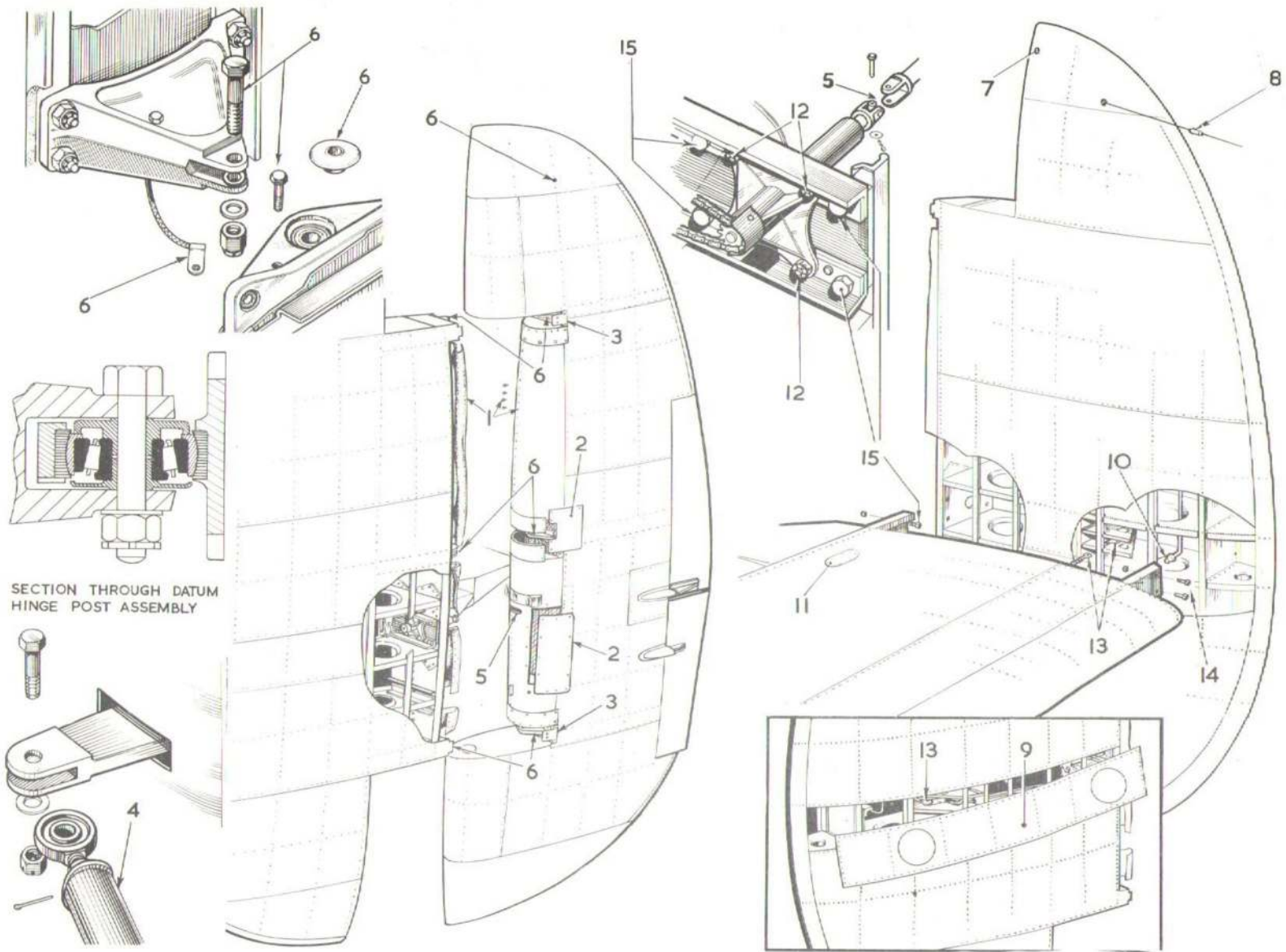
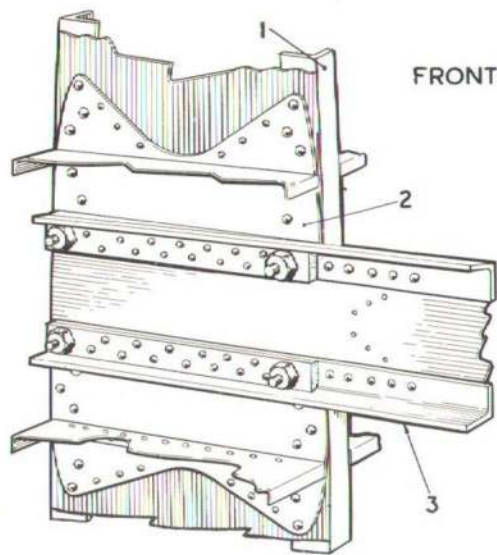
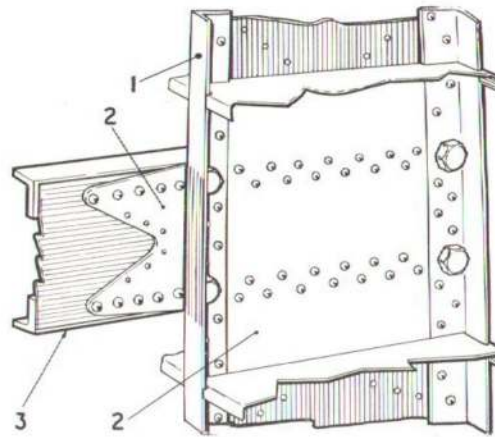

Fig. 4. Removal of rudder and fin
RESTRICTED



FRONT SPAR TO FIN POST

VIEW LOOKING FORWARD



VIEW LOOKING AFT

- | | |
|---|--------------------------------|
| 1 | FRONT FIN POST |
| 2 | REINFORCING PLATE |
| 3 | TAIL PLANE FRONT SPAR |
| 4 | REAR FIN POST |
| 5 | RUDDER TRIM TAB OPERATING GEAR |
| 6 | TAIL PLANE REAR SPAR |

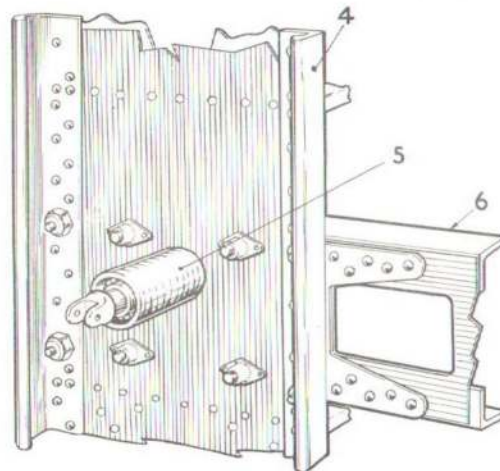

VIEW LOOKING FORWARD

REAR SPAR TO FIN POST

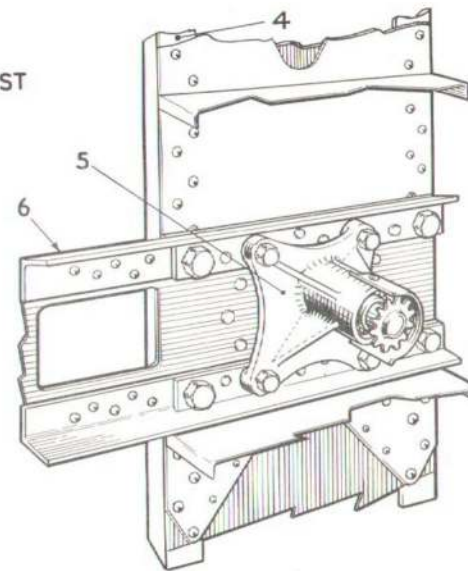

VIEW LOOKING AFT

Fig. 5. Mounting of fin to tail plane
RESTRICTED

FINNS AND RUDDERS

23. Refer to fig. 4 and its associated key and fig. 5.

FINNS ASSEMBLY (fig. 4 and 5)

24. Assembly of the fins and rudders to the tail plane is a reversal of the sequence of operations in fig. 4(1).

(1) Before the fin is assembled to the tail plane spars, the contacting surfaces are to be coated with pigmented varnish jointing compound, Ref.No.33C/1264. The same treatment applies to the jointing bolts and nuts, and also to the rudder trim tab sprocket bracket before it is bolted to the fin post.

(2) When a replacement fin is fitted to the tail plane, the crank (item 13, fig. 4, and item G, fig. 25, Chap.4) will be found to be partly assembled only. This crank must be set as follows:-

(a) Connect the rigid lever of the crank to the end of the tail plane push-pull tube.

(b) Set the loose lever to give linear travel of 2.2 in. to the control rod in the fin when the cockpit control is fully operated. Check that the nut of the bolt in the slotted hole is fully tightened after the lever end has been correctly set.

(c) Remove the crank from the fin and drill the assembly (Morse No.11) to fit 2 B.A. bolts at the holes already present in the lever component to lock the assembly.

(d) The bolts, etc. (2 off each) used in (c) are as follows:-

Part	Ref. No.
Bolt	28D/12533
Washer	28W/12245
Nut	28M/13121
Split pin	28P/12349

(e) Finally, refit the crank in the fin and connect up the rudder locking controls.

ELEVATORS AND TAIL PLANE

25. Refer to fig. 6 and 7.

TAIL PLANE ASSEMBLY (fig. 7)

26. (1) The two halves of the tail plane must be properly trestled before they are inserted into the openings on either side of the fuselage rear section. After alignment, the four bolts which secure the assembled tail plane to the fuselage are inserted.

(2) The front spar attachment bolts (former 37) are inserted with their heads facing forward and must be just tight before the rear spar attachment bolts are inserted.

(3) Before inserting the rear spar bolts the threaded bushes are greased and inserted from aft and screwed in finger tight. The tapered bolts are then inserted, also from aft, and the front spar bolts then tightened until the front spar is making good contact with former 37. Re-adjust the rear attachment threaded bushes until again finger tight, if necessary, and partially tighten the rear attachment bolts.

(4) Measure the gap, if any, between the inner ends of the spars, and insert packing in the form of shims which are provided as spares for this purpose. The thickness of packing to be inserted in the gap according to its size is obtainable from the following table:-

Gap (Over)	Packing (Gauge)	Ref.No. - Section 26FP	
		Front Spar	Rear Spar
0.015 in.	22	1475	1477
0.0625 in.	16	1480	1478
0.0775 in.	16+22	-	-
0.125 in.	10	1476	1479
0.140 in.	10+22	-	-

It is essential that the same combination of shims is used at both spar joints.

(5) When the gap is less than the total thickness of shimming to be inserted, the upper end of the shimming can be inserted first by lowering the beams of the tail plane support trestles until the gaps between the two upper pairs of shoe brackets are opened just sufficiently to allow the end of the shimming to be inserted and located. The shims can then be swung down into their final position by raising the trestle beams to open the lower part of the gap.

(6) After the shims have been correctly positioned to allow the jointing bolts to be inserted, the bolts are fitted as described in the following sub-para.

(7) The protective treatment must be removed from the nuts and bolts.

(8) Care must be taken to ensure that no moisture is present, especially due to handling.

(9) After assembling the nuts and bolts, the nuts must be tightened to a torque of 350 lb. ft. Then increase the torque to insert the split pins. The torque must not exceed 400 lb. ft.

(10) Coat the assembled joints with protective P.X.9.

(11) Finally, the four bolts securing the tail plane to the fuselage are fully tightened up, and the fairing pieces fitted at the joints between the fuselage and the tail plane (Sect.2, Chap.4).

KEY TO FIG. 6 (REMOVAL OF ELEVATOR)

- (1) Disconnect the elevator control rod at the torque shaft lever.

◀ NOTE...

On assembly ensure that packing washers are fitted between inside faces of lever arm and outside faces of control rod eye-end. ▶

- (2) Remove the bonding leads from the torque shaft couplings and lever.
- (3) Disconnect the couplings at each side of the torque shaft and remove the centre portion of the shaft.
- (4) Disconnect the elevator trim tabs at the cable joints in the fuselage between former 37 and 38, and at the turnbuckle in the transverse run aft of the centre of the tail plane rear spar.
- (5) Remove the pulleys at former 41.
- (6) Remove the fairleads and pass the cables of each half elevator through the opening.
- (7) Remove the access doors in the top (and bottom) surfaces.
- (8) Remove the three taper pins securing the elevator torque shaft couplings to the elevator spars and draw the couplings into the fuselage.
- (9) Remove the access doors in the bottom skin just aft of the hinges.
- (10) Remove the bolt and two washers securing the balance tab operating rod to the arm under the centre hinge.
- (11) Support the elevator, remove the split pins and nuts from the hinge bolts and withdraw the elevator until the hinge bolts are clear of the spar.

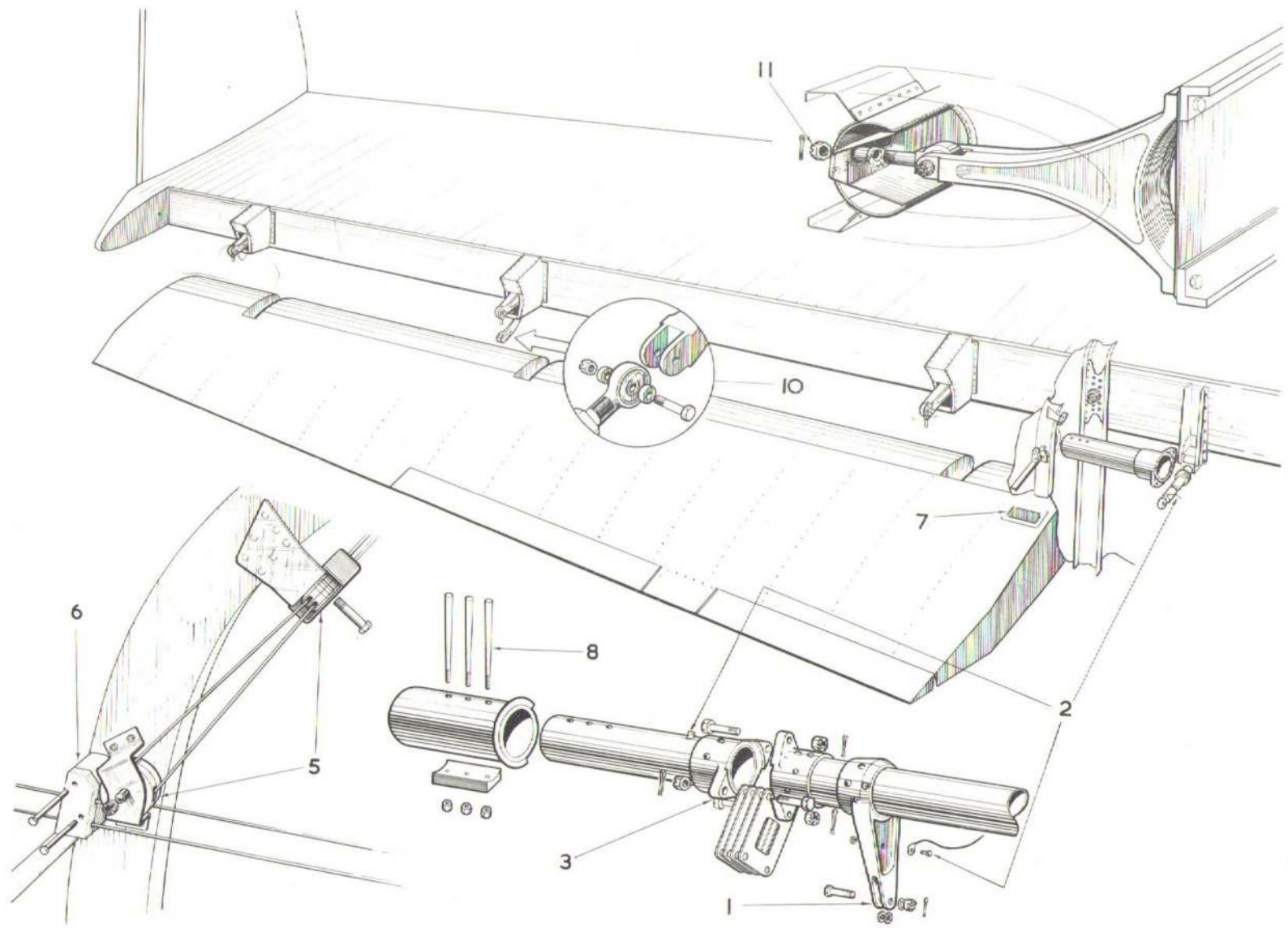

Fig. 6. Removal of elevator
RESTRICTED

KEY TO FIG. 7 (REMOVAL OF TAIL PLANE)

- 1 Trestle both sides of the tail plane (for trestling equipment and arrangement refer to Sect.2, Chap.4).
- 2 Remove the rudder and the fin (fig. 4 and 5).
- 3 Remove the elevator (fig. 6).
- (4) Remove the tail plane root fairings (Sect.2, Chap.4).
- 5 Remove the two inspection panels (four if both halves of the tail plane are to be removed) on the undersurface of the tail plane in the fuselage.
- (6) Disconnect the fin de-icing system piping at the T-union aft of the front spar.
- (7) Disconnect the leading-edge de-icing system piping through the access panel on the undersurface of the tail plane.
- (8) Disconnect the rudder locking controls and bonding at the points illustrated and at the other end of the control rod (8a) at the tail plane centre (not illustrated), secure the rod (8b) to the control rod leading aft to the elevator locking system.
- (9) Disconnect all bonding and the starboard rudder push-pull control rod from the lever on the upper torque tube, and the upper torque tube from the fuselage vertical torque tube.
- (10) Disconnect the rudder trim cables at the chain joints aft of the sprocket shaft above the front spar. Free the cables from the pulleys, disconnect the turnbuckles in the transverse run and coil the ends inside their respective halves of the tail plane.
- (11) Disconnect the short turnbuckle connecting the bell-crank at the aft end of the elevator locking control rod to the sliding bar in the port elevator stop bracket on the aft face of the rear spar. Remove both the stop brackets from the rear spar to allow withdrawal of the starboard half of the tail plane.
- (12) Remove the bolts at the top and bottom joints at the centre of the tail plane.
- (13) Remove the bolts securing the tail plane to formers 37 and 41.

WARNING...

Care must be taken when removing the port half of the tail plane to ensure that the shoe brackets of the centre joint do not foul the brackets supporting the rudder and elevator locking system.

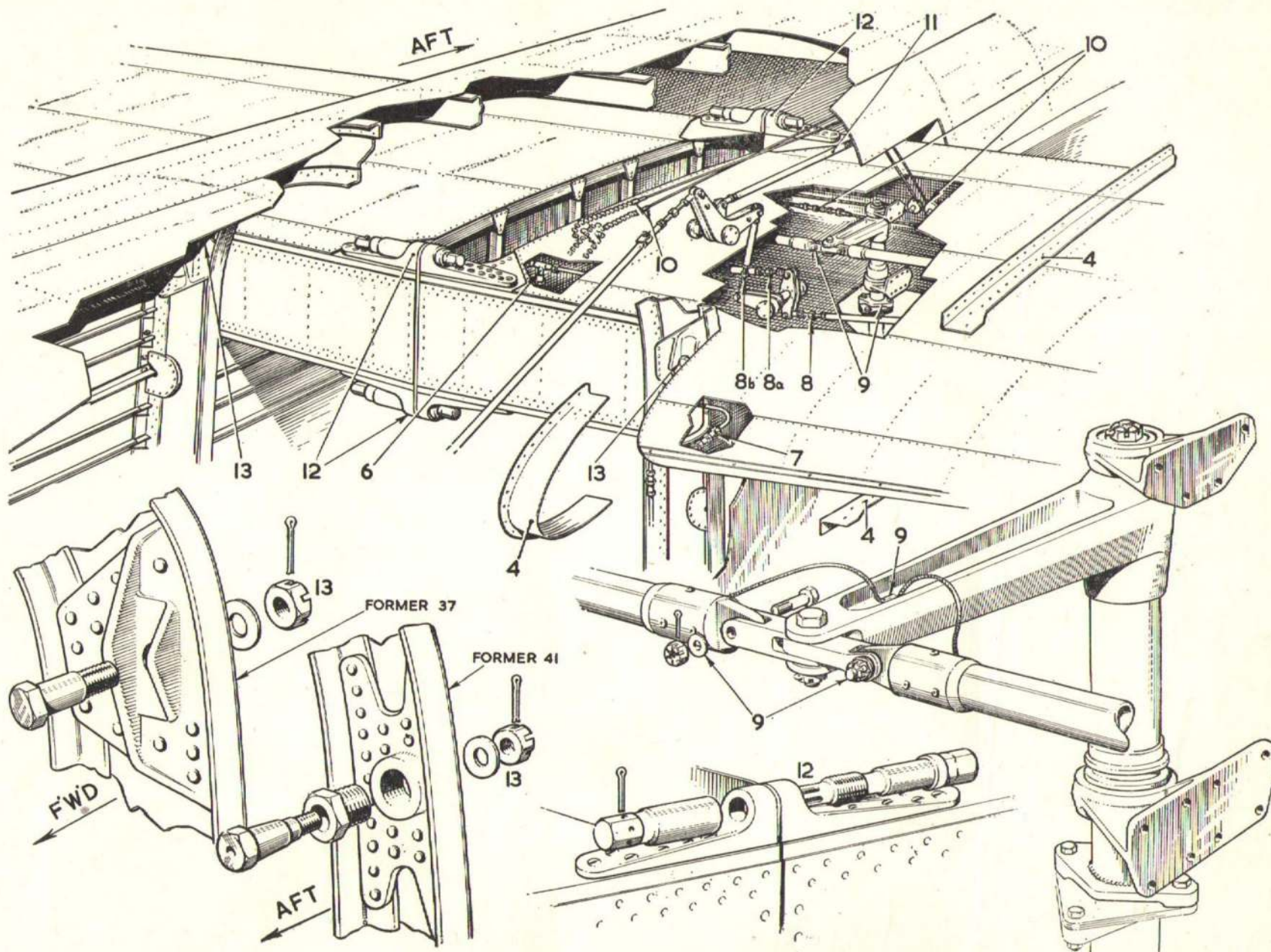

Fig. 7. Removal of tail plane



This file was downloaded
from the RTFM Library.

Link: www.scottbouch.com/rtfm

Please see site for usage terms,
and more aircraft documents.



LIGHTNING MK. 1
COVER PITOT HEAD
EB2-88-5111