

Chapter 5

ALIGHTING GEAR

LIST OF CONTENTS

DESCRIPTION	Para.	SERVICING	Para.	Setting the wheel compartment doors	Para.
Introduction	1	Lubrication	13	Main undercarriage	26
Alighting gear units		Components	14	Tail undercarriage	27
Main-wheel units	2	Main-wheel units	15	Setting tail undercarriage jack	28
Wheels and brakes	3	Shock-absorber struts	16	REMOVAL AND ASSEMBLY	
Axle attachment	4	Inflation adapter	17	Introduction	29
Radius rods and locks	5	Deflating	18	Removal	
Operating jacks	6	Oil level check	19	Main-wheel units	30
Tail-wheel unit	7	Topping up with oil	20	Tail wheels	31
Wheel compartments		Air pressure check	21	Tail-wheel unit and doors	32
Main wheels	8	Tail-wheel unit	22	Main undercarriage doors	
Valances	9	Setting the up-lock catch-pins		and valances	33
Doors	10	Main-wheel units	23	Undercarriage beams	34
Undercarriage beams	11	Tail-wheel unit	24	Assembly... ..	35
Tail-wheel compartment and doors	12	Setting the main-wheel unit down-lock	25	Main-wheel unit shock-absorber panels	36
				Tail-wheel unit	37

LIST OF ILLUSTRATIONS

	Fig.		Fig.
Main-wheel unit	1	Removal of main-wheel unit ...	7
Tail-wheel unit	2	Removal of undercarriage doors and valances	8
Tail-wheel doors	3	Removal of undercarriage beams (1)	9
Main-wheel strut inflation	4	Removal of undercarriage beams (2)	10
Setting the main undercarriage up-locks	5		
Setting the tail undercarriage jack	6		

DESCRIPTION

Introduction

1. All units of the alighting gear are retractable, and are actuated hydraulically. The main wheels retract into compartments in the inboard nacelle fairings and the twin tail wheels retract into a compartment in the underside of the rear fuselage between formers 37 and 41. The construction of this compartment, together

with the surrounding fuselage structure, is illustrated in Chap.1 of this section.

ALIGHTING GEAR UNITS

Main-wheel units (fig.1)

2. These are direct action backward-retracting structures (Dowty A.944Y).

Each complete unit consists of a panel formed by two oleo-pneumatic shock-absorbers (Leading Particulars) connected at their lower ends by the wheel axle and by a tie bar, stiffened by K-bracing, at their upper ends, together with two retraction struts each operated by a hydraulic jack. A description of the unit is given in A.P.1803E, Vol.1.

RESTRICTED

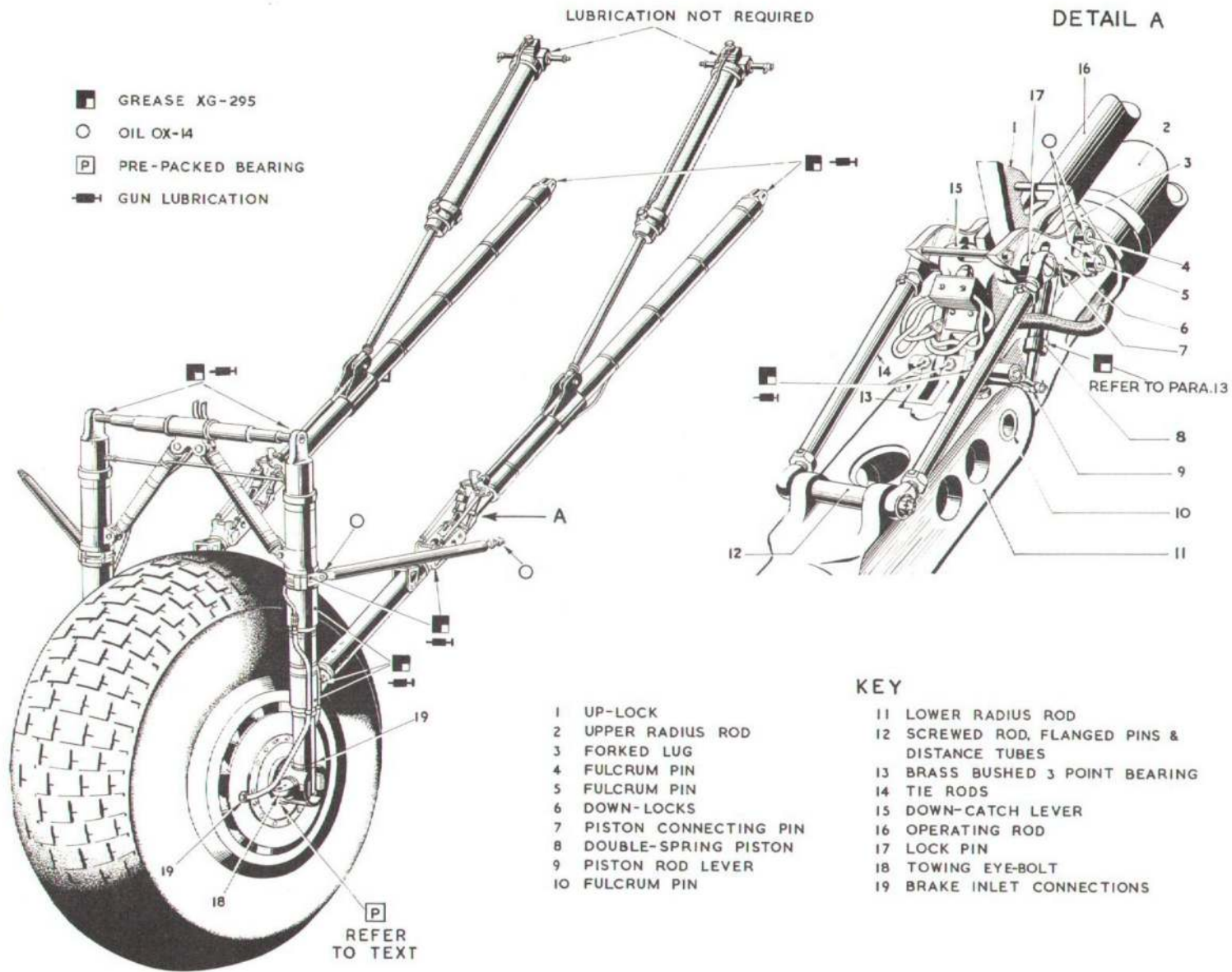

Fig.1. Main-wheel unit
 (Amendment to symbols)
RESTRICTED

Wheels and brakes

3. Particulars of the wheels are contained in Leading Particulars. The wheels run on taper roller bearings and the twin brake assemblies, which each have four pneumatic brake-operating bags arranged as two concentric pairs in tandem, are secured by bolts to torque flanges bolted to the axle. Provision is made for removing and fitting the tyres by the use of detachable rim flanges held by locking rings. The wheels and brakes are described in A.P.2337, Vol.1.

Axle attachment

4. This is effected by internally threaded eye-bolts, with a head at one end, which pass through both the axle ends and the bottom of each shock-absorber strut. Each pin is retained by an eye-bolt and the assembly is packed by suitable packing pieces. These eye-bolts serve as attachment points for towing bridles (Sect.2, Chap.1).

Radius rods and locks

5. A description of the radius rods, together with the action of the down-locks, is contained in A.P.1803E, Vol.1. The up-lock hooks are also described and these engage with an assembly secured to the roof of each main-wheel compartment (fig.5) and located between main plane centre section stringers No.3 and 4, counting from the front. The alighting gear position indicator is operated by a micro switch, for the down indication,

WARNING...

At all times of servicing this system, when the aircraft is not resting on jacks, the jury struts must be fitted to port and starboard alighting gear.

mounted on one of the radius rods of each unit and, for the up indication, mounted on an adjustable up-lock-catch assembly which is secured to the wing structure (Book 2, Sect.5, Chap.1).

Operating jacks

6. These are secured at their lower ends to the retraction struts and at their upper ends to brackets bolted to the rear spar (fig.6).

TAIL-WHEEL UNIT (fig.2)

7. A description of this unit (Leading Particulars) is given in A.P.1803E, Vol.1, Sect.5, Chap.6. It is secured to the airframe as shown in the illustration.

WHEEL COMPARTMENTS**Main wheels**

8. The upper portion of each main-wheel compartment is constructed as described in Chapter 2 of this section. The lower portions each consist of two valances and two undercarriage doors which form the middle sections of the inner engine nacelles, forward of the rear nacelle fairings (Sect.4, Chap.1).

Valances (fig.8)

9. The upper edge of each valance is formed by a wide channel-section member which is secured to the undersurface of the centre plane, whilst the lower edge is of normal channel section and carries a

SERVICING**LUBRICATION**

13. Points requiring periodical lubrication are indicated in fig.1, 2 and 3. The lubricants to be used are grease XG-295 and oil OX-14. The tail wheel axle bearings are packed on assembly with grease XG-270. Main wheel bear-

piano type hinge for the undercarriage door. Between these two edges are channel-section ribs which are crossed by stringers. The whole assembly is covered on its outer surface with light-alloy sheet and is bolted to channel-section brackets attached to the engine ribs. The lower edge is extended forward and attached to the firewall, forming an attachment rail for the cowling aft of the firewall. Additional bracing is effected by struts of lipped-channel-section bolted to the bottom of the front spar and to the lower edge extension just forward of the front end of the valance.

Doors (fig.8)

10. Each door consists of a channel-section hinge beam and a lower edge member with ribs and stringers all riveted together and covered with light-alloy sheet. They are opened and closed by connecting rods attached at one end to ball-bearing eye-bolts at the lower edges of the doors and at the other end, to collars on the shock-absorber struts.

Undercarriage beams (fig.9 and 10)

11. These are described and illustrated in Sect.4, Chap.1 and in the illustrations in this Chapter.

TAIL-WHEEL COMPARTMENT AND DOORS (fig.2 and 3)

12. The compartment is described in Sect.3, Chap.1, the mounting and doors are shown in the illustrations.

ings must be assembled with grease XG-277. It is necessary to remove the double-spring piston (fig.1) in order to pack the cylinder with grease XG-295. Care must be taken when removing this item as the large spring is in slight compression.

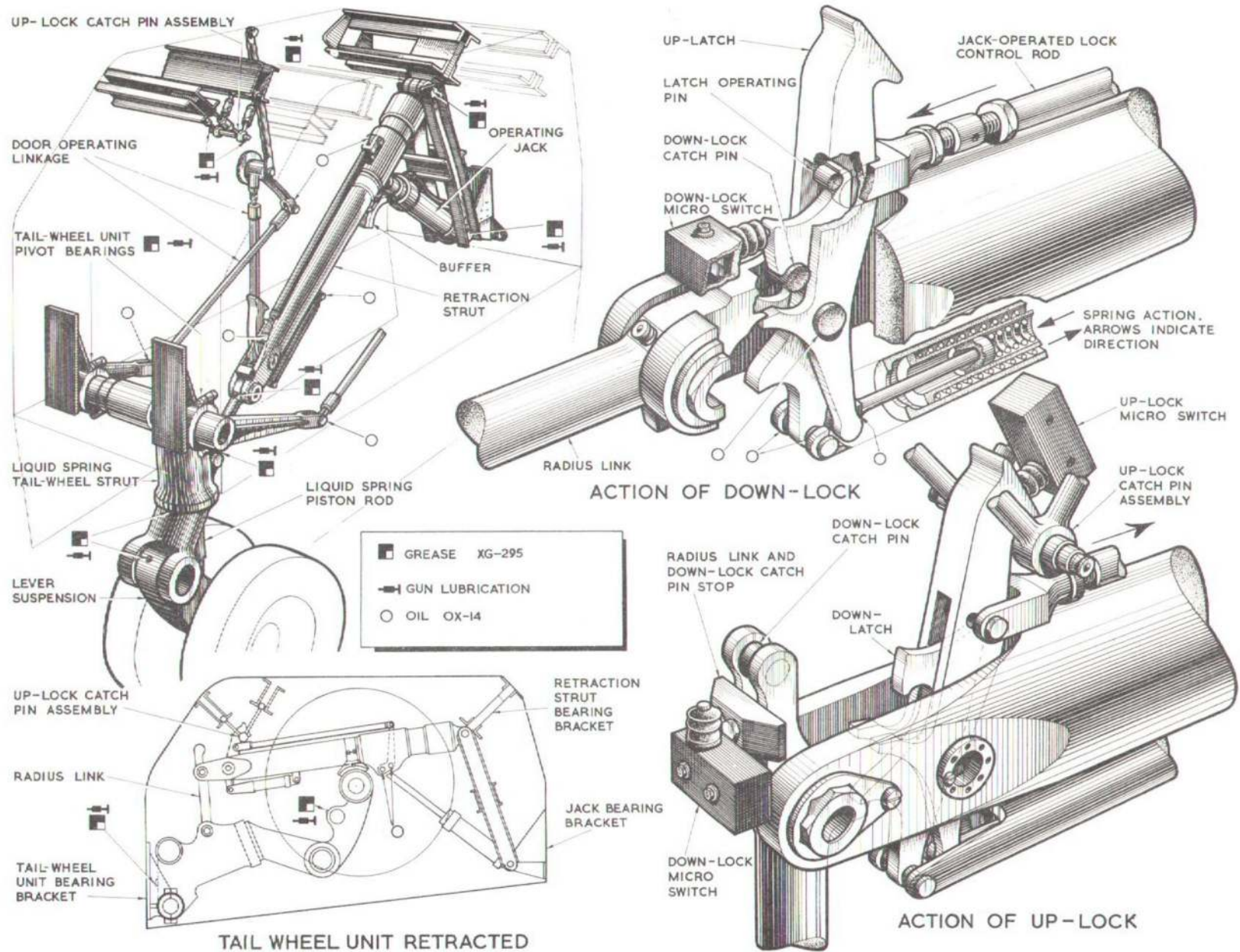

Fig.2. Tail-wheel unit
 (Amendment to symbols)
RESTRICTED

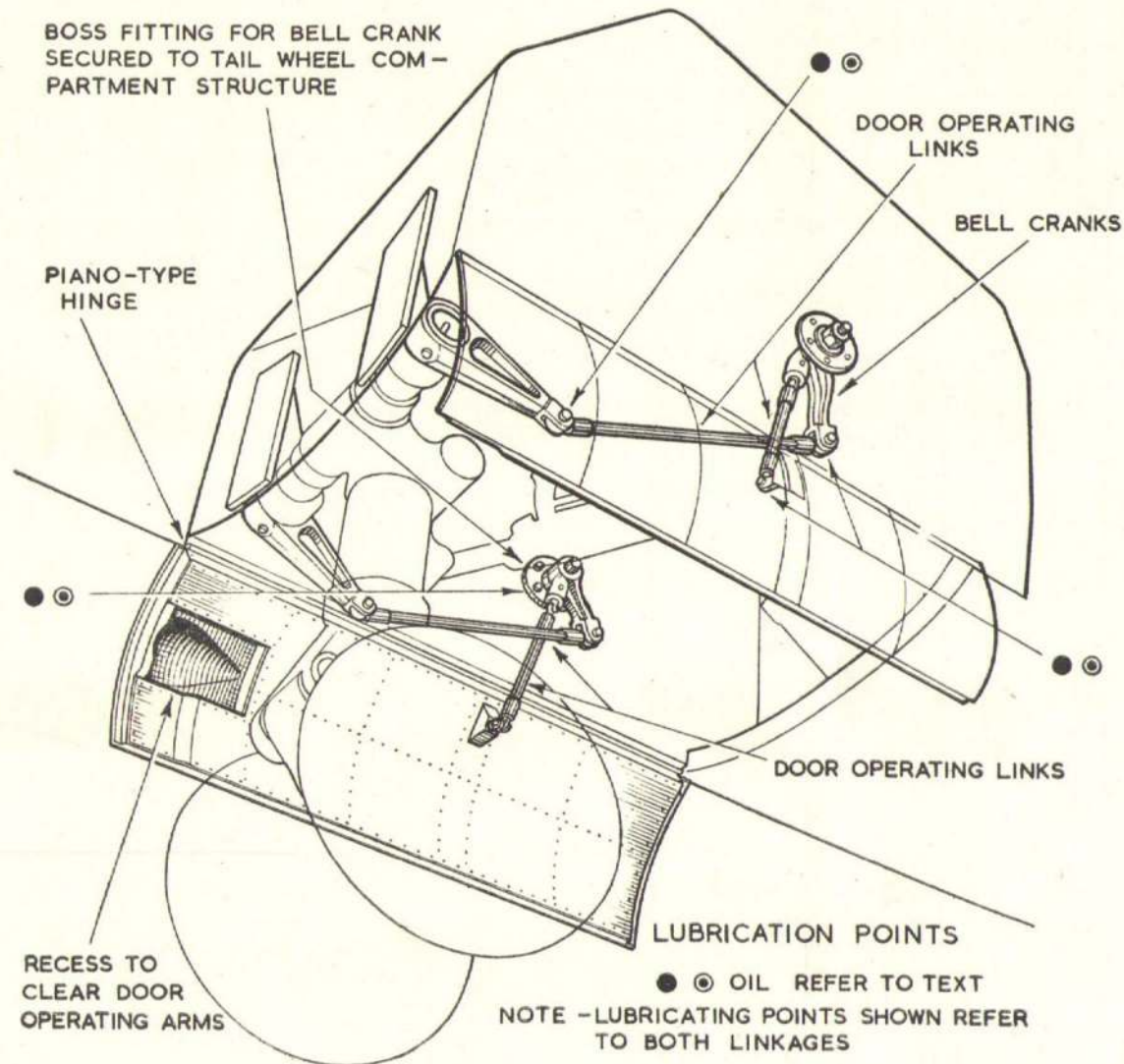

Fig. 3. Tail wheel doors

COMPONENTS

14. Servicing instructions for all components are contained in A.P.1803E, Vol. 1, and in the following paragraphs.

Main wheel units**WARNING**

On no account should any bolts or pipe connections be loosened without first deflating the struts. Failure to observe this warning may result in a serious accident.

15. Removal of the wheel tyres is described in A.P.2337, Vol. 1. The servicing instructions contained in A.P.1803E, Vol. 1, are amplified, where necessary, in the following paragraphs.

Shock-absorber struts

16. Refer to Leading Particulars for the Part No. and for the oil to be used.

Inflation adapter

17. The standard adapter, Stores Ref. 4G/4131 is to be used.

Deflating

18. Remove the dust cap from the inflation valve and fit the adapter. Release the air pressure by screwing up the gauge head and unscrewing the air release valve.

Oil level check

19. Do not attempt to make this check immediately after landing or taxiing. The check is made as follows:—

- (1) With the aircraft standing on its wheels, deflate the struts (*para.* 18) until they are fully compressed.
- (2) If, in the final stage of compression, a spray of oil and air is blown off, the oil level is correct and the struts may be inflated.
- (3) If only air is blown off, the oil level needs topping-up.

(A.L.82, Mar. 55)

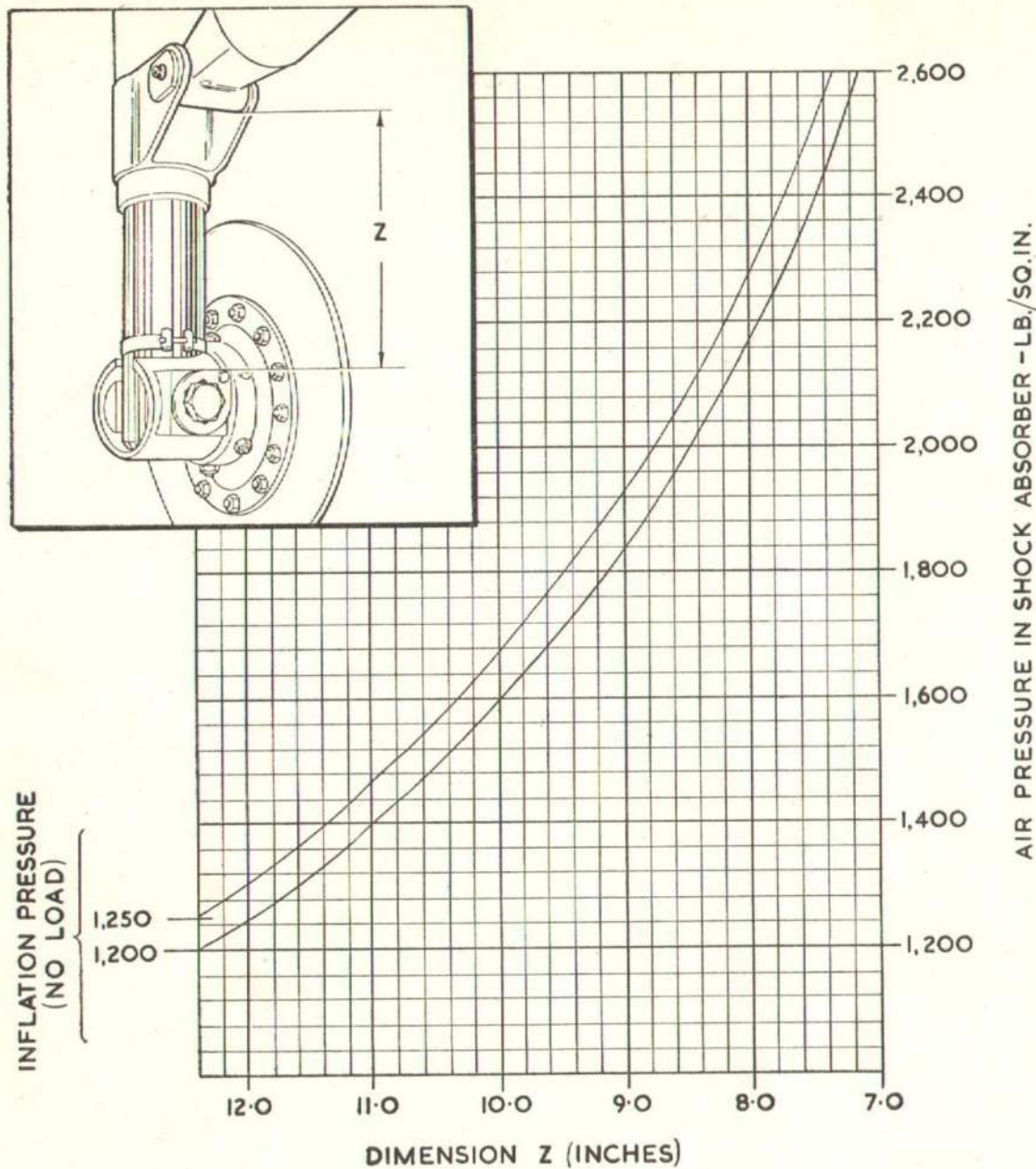

Fig. 4. Main wheel strut inflation

Topping up with oil

20. Proceed as follows:—

- (1) Jack the aircraft to lift the main wheels clear of the ground and deflate the struts (*para. 18*).
- (2) Pump oil into the struts through the inflation valve, using an adapter, until the pressure begins to rise rapidly. Do not allow the pressure to exceed 100 lb. per sq. in.
- (3) Slowly release the pressure by screwing up the adapter gauge head and unscrewing the release screw and make the check indicated in *para. 19*. If necessary, pump in more oil and repeat the check until surplus oil is blown off.
- (4) Disconnect the pump and connect an air supply to the adapter.
- (5) Inflate to the correct pressure at no load (*Leading Particulars*).
- (6) Disconnect the air supply, remove the inflation adapter and re-fit the inflation valve dust cap.

Air pressure check (fig. 4)

21. To check the pressure, proceed as follows (with the aircraft standing on the ground):—

- (1) Remove the dust cap from the inflation valve, connect an inflation adapter and test the pressure.
- (2) Measure the extension of the struts (as shown in the illustration) and compare with the dimension given on the graph for the pressure recorded.
- (3) If the pressure is below the minimum stated for the corresponding dimension, attach an air supply to the inflation adapter and inflate the struts, checking the extension at intervals, until the pressure and extension are within the limits given in the graph.
- (4) Disconnect the air supply and adapter and re-fit the inflation valve dust cap.

RESTRICTED

Tail-wheel unit

22. Servicing instructions are contained in A.P.1803E, Vol.1, Sect.5, Chap.6. The equipment to be used for charging the liquid spring, to 2,000 p.s.i. with oil at no load/full extension, is a charging pipe (Part No.D2606Y) and a high-pressure charging gun (Ref.No.1B/4467).

SETTING THE UP-LOCK CATCH-PINS**Main-wheel units**

23. The roller-type catch pin is set by adjusting the four turnbuckles. Jack the aircraft, retract the main wheels and maintain them fully retracted by use of the hydraulic handpump or a hydraulic servicing trolley.

- (1) Adjust the turnbuckles until a clearance of $0.125_{-0.0}^{+0.03}$ in. is obtained between the top of the roller circumference and the up-lock catch, with the forward part of the roller circumference just touching the catch.

Tail-wheel unit

24. Ensure that the setting of the down-lock is correct (A.P.1803E, Vol.1, Sect.5, Chap.6) before setting the up-lock catch pin. Then proceed as follows:-

- (1) Retract the tail-wheel unit and ensure that it is up as far as it will go.
- (2) Remove the narrow access panel which extends the full width of the forward upper part of the wheel compartment structure over the up-lock pin turnbuckle attachment brackets.
- (3) Adjust the turnbuckles until a clearance of 0.050 in. is obtained between the top of the catch-pin

and the up-lock catch, with the forward part of the catch-pin circumference just touching the up-lock catch. This means that, if hydraulic pressure is released from the jack, the uplock catch will fall 0.050 in. before being arrested by the pin.

- (4) Fit the access panel removed in sub-para.(2).

SETTING THE MAIN-WHEEL UNIT DOWN-LOCK

25. To set the main-wheel unit down-lock proceed as follows:-

- (1) Jack the aircraft with all wheels clear of the ground (Sect.2, Chap.4).
- (2) Disconnect the retracting jack from the radius rod lugs.

NOTE:- ON AIRCRAFT NOT INCORPORATING MOD.346 A CATCH PIN IS FITTED INSTEAD OF A ROLLER. IN THIS CASE SET HOOK WITH $1/32$ IN. INTERFERENCE AND NOT WITH CONTACT ONLY

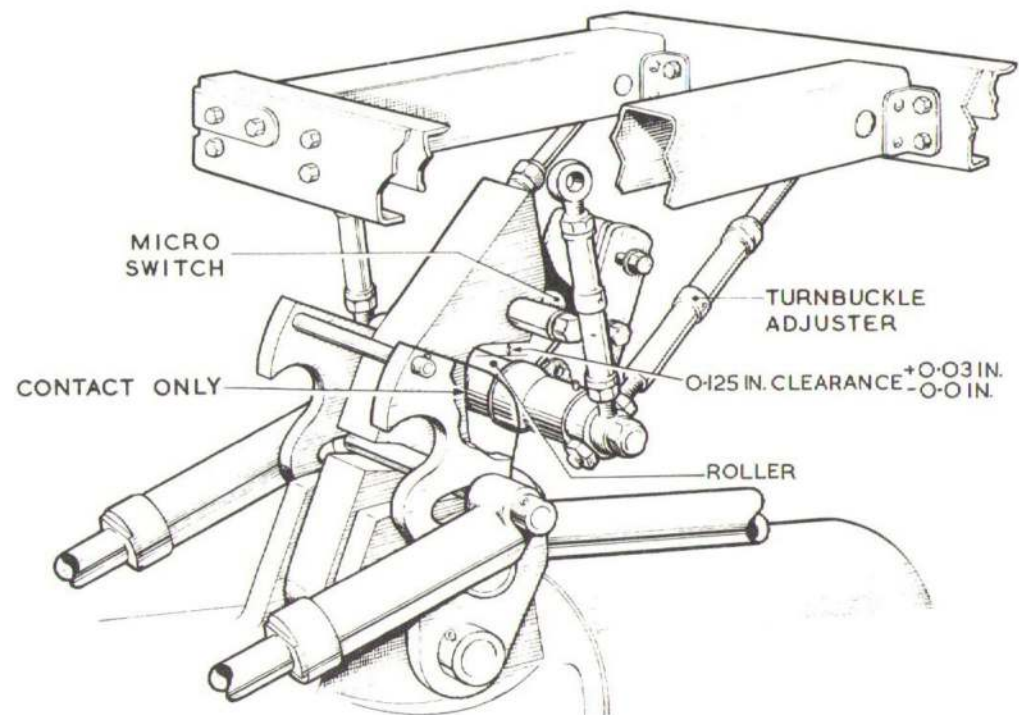

Fig.5. Setting the main undercarriage up-locks

RESTRICTED

- ◀ (3) Check that a clearance of 0.005 to 0.020 in. exists between the top face of the down-lock pin and the down-lock catches. To obtain this clearance disconnect the down-lock side struts and adjust on the shims fitted on the under surface of the arrester block.
- (4) Fit the down-lock side struts, adjusting as necessary, until the centre of the retracting strut hinge pin is above a datum line passing through the centres of the retracting strut attachment bolts, this measurement must not exceed 0.10 in.
- (5) Apply hydraulic pressure to the down side of the jack.
- (6) Adjust on the jack piston rod eye-end until the attachment pin can just be inserted when the eye-end and the radius rod lugs are brought together, with the pin at the bottom end of slot.
- (7) Unscrew the jack eye-end a further one half turn. This ensures that the jack does not bottom before the the down-lock is fully engaged.
- (8) Release the hydraulic pressure and secure the jack and jack extension tube to the radius rod lugs using the attachment pin. Fit the nut to the attachment pin and lock by a split pin.
- (9) Apply hydraulic pressure to the down side of the jack.
- (10) Adjust, if necessary, the jack extension tube and connect the tube fork-end, using the pin provided, so that it picks up the down-lock catch, the up-lock catch and the radius rod lugs. Ensure that the pin does not bottom in the lug slots.

- (11) Check the jack extension tube fork-end and end fitting for safety. Lock the fork-end ensuring that the split pin engages in the slots on the extension tube.
- (12) After setting all down-locks carry out an undercarriage retraction test to check for correct operation. ▶

SETTING THE WHEEL COMPARTMENT DOORS

Main undercarriage

26. This operation is carried out as follows:-

- (1) Jack the aircraft with all wheels clear of the ground (Sect.2, Chap.4).
- (2) Remove the bolts securing the adjustable ends of the operating rods to the rotating pins on the doors.
- (3) Retract the alighting gear.
- (4) Push one of the doors to the closed position and adjust the length of the operating rod until the bolt (sub.para.2) can be freely inserted with the door held in the closed position.
- (5) Repeat this procedure for the remaining doors.
- (6) Lower the alighting gear, fit the the bolts to secure the operating rods to the rotating pins and lock the bolts.
- (7) Retract the alighting gear and check that the doors close properly.

Tail undercarriage

◀ 27. To set the tail undercarriage doors proceed as follows:-

- (1) Jack the aircraft with all wheels clear of the ground (Sect.2, Chap.4).
- (2) Remove the operating rods from the tail-wheel unit to the bell-crank and from the bell-crank to the doors.
- (3) Retract the alighting gear.
- (4) Close the port door and retain, by hand, in the fully closed position. Set the bell-crank to door operating rod to a length of 9 ± 0.06 in. and connect it to the bell-crank and the doors.
- (5) With the door retained in the closed position, connect the tail unit to bell-crank operating rod. Adjust, as necessary, on the rod until the attachment bolts can be freely inserted. Lock the adjustment point.
- (6) Disconnect the operating rod from the door and open the door.
- (7) Repeat operations (4) and (5) on the starboard door.
- (8) Lower the alighting gear, ensuring that the disconnected rod (sub.para.6) does not foul on the surrounding structure.
- (9) Connect the operating rod to the port door and lock all attachment bolts.
- (10) Carry out a retraction test checking that the doors align properly with the aircraft skin contour.

SETTING TAIL UNDERCARRIAGE JACK

28. To set the tail-wheel unit operating jack proceed as follows:-

- (1) Jack the aircraft with all wheels clear of the ground (Sect.2, Chap.4). ▶

RESTRICTED

Fig. 6. Setting the tail undercarriage Jack

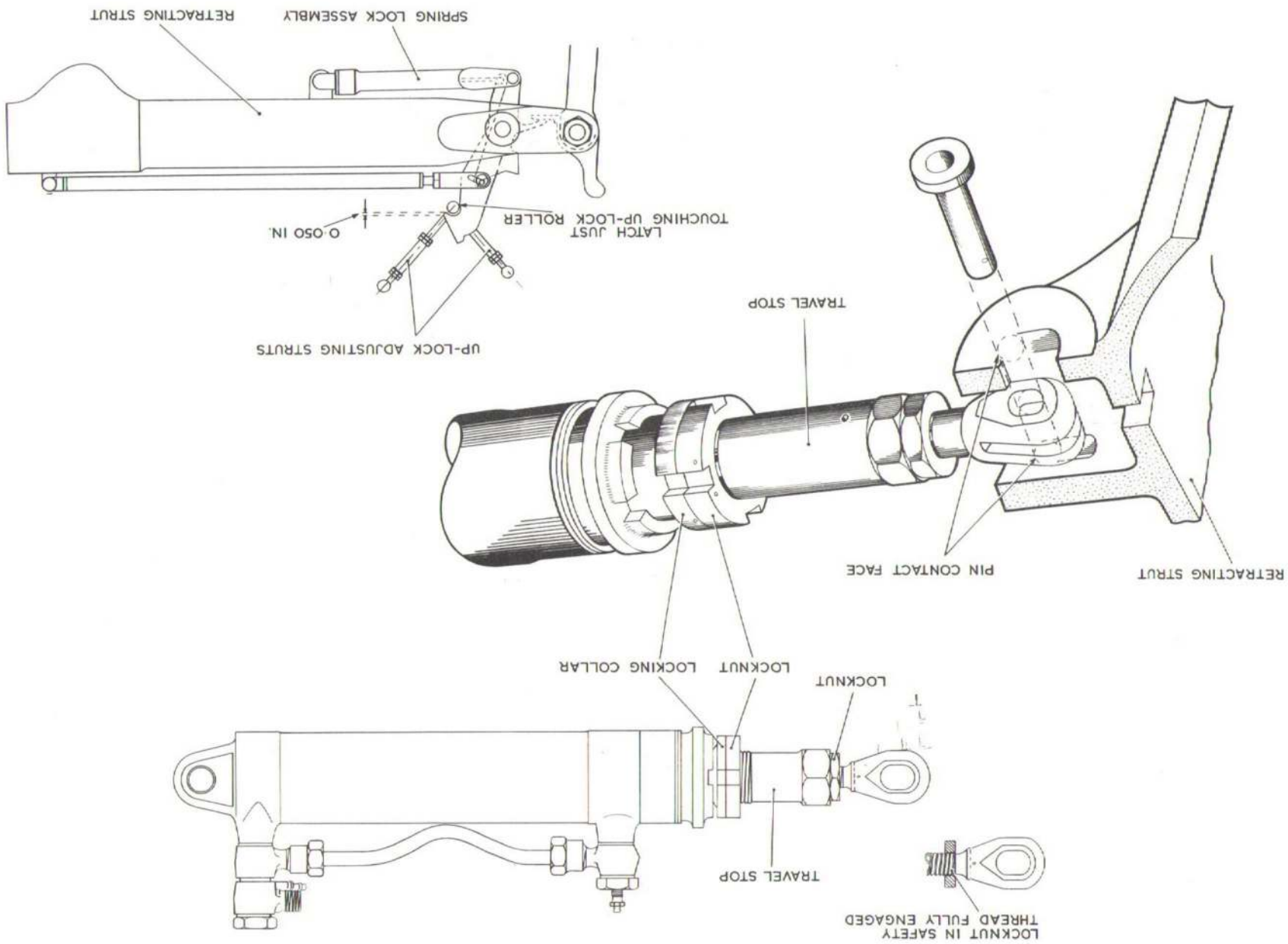

- (8) Retract the tail undercarriage ensuring that the tail undercarriage assembly does not foul the adjacent tail-wheel bay structure and that the tail-wheel axle fits snugly into the tail strut buffer.
- (9) Ensure that the tail undercarriage is fully retracted and set the up-lock catch pins (para.24).
- (10) Lower the tail undercarriage, check all locknuts and the interference of the operating jack/radius rod attachment pin (sub.para.5).
- (11) Wirelock the travel stop locknut to locking collar and the fork-end locknut and the travel stop by two turns in figure-of-eight.
- (12) Connect the tail undercarriage bay doors to the operating linkage and carry out a retraction test.

from the bell-crank at each side of the wheel compartment and the link connecting the bell-crank to each door.

- (6) Remove the doors by releasing the screws securing the hinges to the compartment rails.
- (7) Remove the set bolts, locking plates, nut and special pin from the fork at the rear of the unit main fitting to disconnect the radius rod (fig.2).

- (8) Support the unit body, release the bolts securing the saddle caps of the pivot shaft bearing, attached to the airframe, and carefully withdraw

attachment pin by hand with the pin bearing on the lower face of the radius rod lug slots and the top face of the jack fork-end attachment hole.

NOTE...
Effective travel of the jack is 7.9 ± 0.125 in., on aircraft with operating jack 1.01069.001 fitted, the jack has 0.2 in. idle travel catered for by a slot in the fork-end. One complete turn on the travel stop locking collar is equivalent to 0.050 in. travel of the jack.

- (6) When the interference is established turn the jack travel stop collar out a further one-eighth of a turn, thereby ensuring a positive interference.

- (7) Release the hydraulic pressure from the jack and tighten the travel stop collar locknut.

REMOVAL AND ASSEMBLY

- (1) Chock the main wheels fore and aft and jack the aircraft tail (Sect. 2, Chap.4).

- (2) Remove the twin wheels by releasing the nuts securing them to the serrated flanges on the axle.
- (3) Release the door operating links from the arms at each end of the unit pivot shaft (fig.3).

- (4) Remove the split pins from the pin securing the door lever to the unit pivot shaft. Remove the securing pin and slide the arms off the pivot shaft.

- (5) Release both door operating links

- (2) Disconnect the operating jack from the radius rod and the tail undercarriage bay doors from the operating linkage.

- (3) Set the operating jack fork-end in safety, i.e., the locknut fully engaged on all threads and in line with the thread undercut.

- (4) Release the lock-nut and locking collar on the operating jack travel stop and apply hydraulic pressure to the down side of the jack.

- (5) Adjust the operating jack travel stop collar to obtain the right degree of interference between the jack attachment pin and the operating jack fork-end and the radius rod attachment slots. The correct degree of interference is such that with hydraulic pressure on the down side of the jack considerable effort is required to rotate the

REMOVAL

Introduction
29. The instructions contained in the following paragraphs are supplementary to those contained in the relevant chapters of A.P.1803E, Vol.1.

Main-wheel units

30. The procedure is illustrated in fig.7.

Tail wheels

31. Carry out the first two operations contained in para.32.

Tail-wheel unit and doors

32. These operations are carried out as follows:-

- 1 JACK THE AIRCRAFT (SECT. 2, CHAP. 4) UNTIL THE WHEEL IS APPROXIMATELY FIVE INCHES CLEAR OF THE GROUND.
- 2 DEFLATE THE SHOCK-ABSORBERS.
- (3) RELEASE THE BRAKES. DISCONNECT THE BRAKE PIPES AT THE TOP END OF THE FLEXIBLE TUBING AND AT EACH SIDE OF THE WHEEL.
NOTE...
THE BRAKE CONNECTIONS MUST BE LEVEL ON ASSEMBLY.
- (4) SUPPORT THE WHEEL.
- (5) REMOVE THE EYE-BOLTS, SADDLE WASHERS AND PACKING PIECES SECURING THE AXLE TO THE SHOCK-ABSORBER STRUTS AND REMOVE THE WHEEL.
- (6) DISCONNECT THE JACK PISTON RODS.
- (7) DISCONNECT THE RADIUS RODS AT THE SHOCK-ABSORBER STRUTS.
- (8) DISCONNECT THE UNDERCARRIAGE DOOR-OPERATING LINKS AT THE EYE-BOLTS ON THE DOOR.
- (9) REMOVE THE BOLTS SECURING THE TOP END FITTINGS OF THE SHOCK-ABSORBER TO THE UNDERCARRIAGE BEAMS AND REMOVE THE SHOCK-ABSORBER ASSEMBLY.
- (10) DISCONNECT THE HYDRAULIC PIPE UNIONS AT THE TOP END OF THE JACKS AND THE BOLTS ATTACHING THE JACKS TO THE REAR SPAR BRACKETS.
- (11) DISCONNECT THE ELECTRICAL CABLES AT THE TERMINAL BLOCKS ON THE KNUCKLE JOINTS AND UNCLIP FROM THE RADIUS RODS.
- (12) REMOVE THE BOLTS ATTACHING THE RADIUS RODS AND REMOVE THE RADIUS ROD ASSEMBLIES.
NOTE...
OPERATIONS NOT IN BRACKETS ARE NOT ILLUSTRATED.

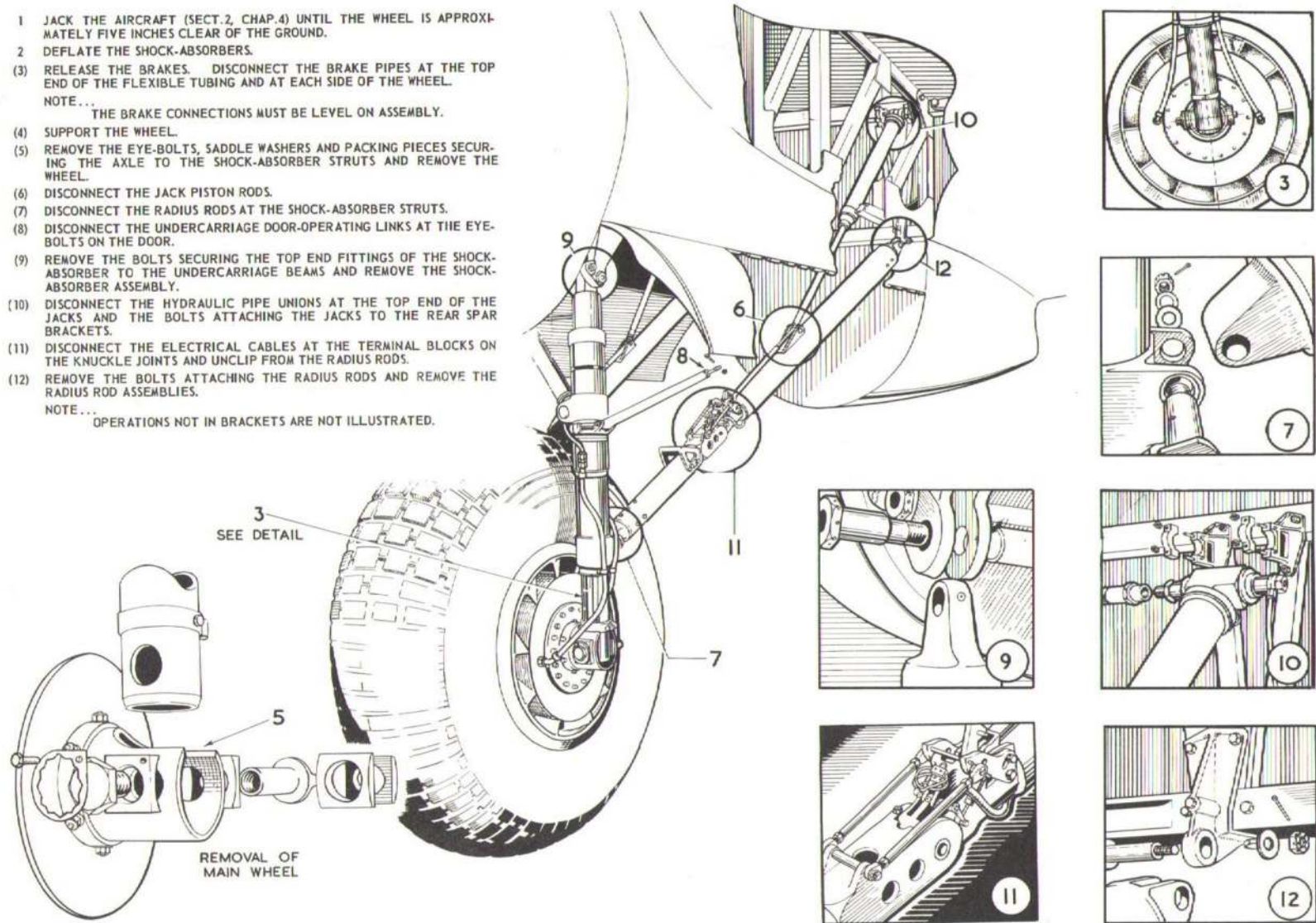
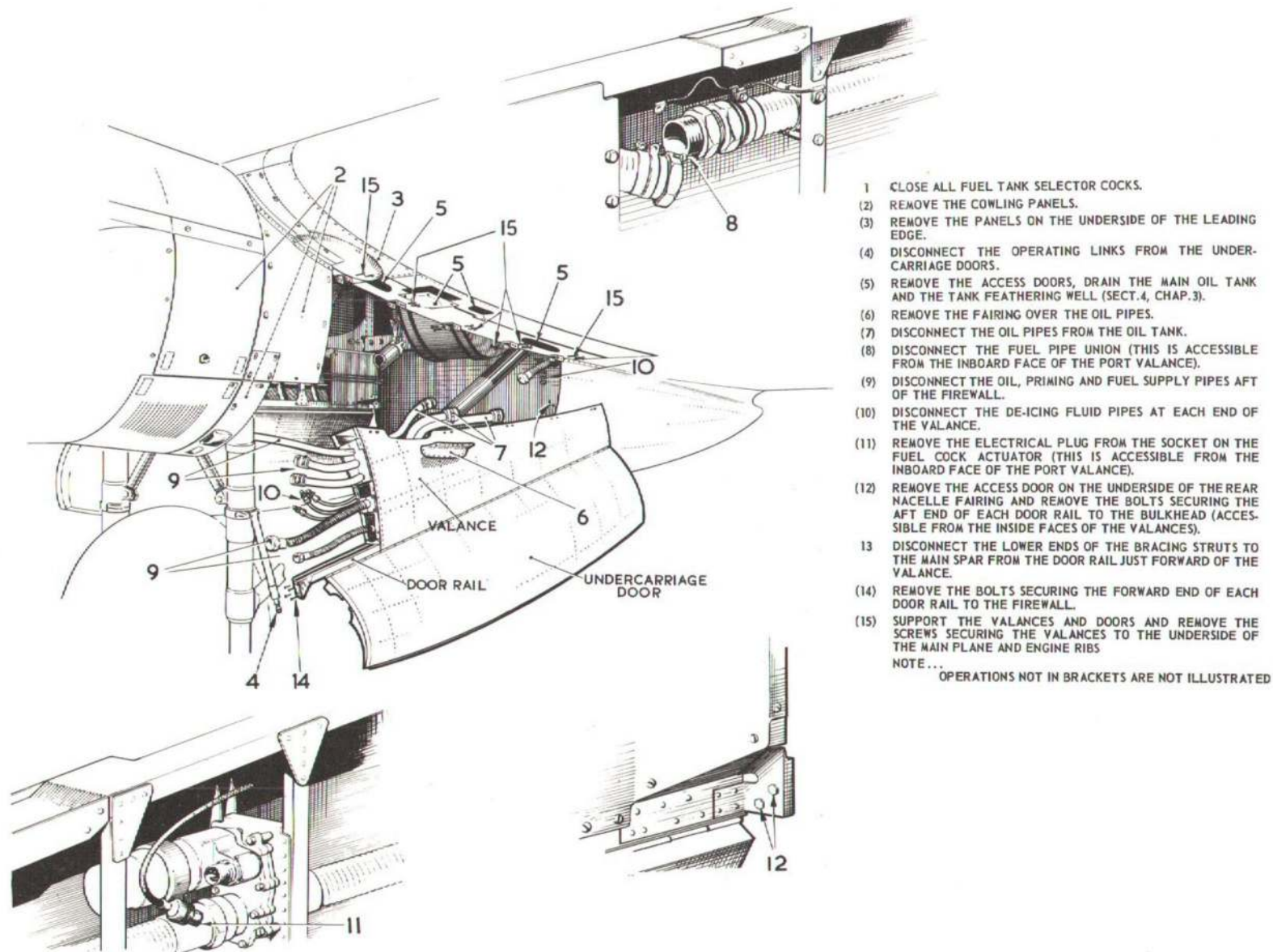

Fig. 7. Removal of main-wheel unit

RESTRICTED



- 1 CLOSE ALL FUEL TANK SELECTOR COCKS.
- (2) REMOVE THE COWLING PANELS.
- (3) REMOVE THE PANELS ON THE UNDERSIDE OF THE LEADING EDGE.
- (4) DISCONNECT THE OPERATING LINKS FROM THE UNDERCARRIAGE DOORS.
- (5) REMOVE THE ACCESS DOORS, DRAIN THE MAIN OIL TANK AND THE TANK FEATHERING WELL (SECT.4, CHAP.3).
- (6) REMOVE THE FAIRING OVER THE OIL PIPES.
- (7) DISCONNECT THE OIL PIPES FROM THE OIL TANK.
- (8) DISCONNECT THE FUEL PIPE UNION (THIS IS ACCESSIBLE FROM THE INBOARD FACE OF THE PORT VALANCE).
- (9) DISCONNECT THE OIL, PRIMING AND FUEL SUPPLY PIPES AFT OF THE FIREWALL.
- (10) DISCONNECT THE DE-ICING FLUID PIPES AT EACH END OF THE VALANCE.
- (11) REMOVE THE ELECTRICAL PLUG FROM THE SOCKET ON THE FUEL COCK ACTUATOR (THIS IS ACCESSIBLE FROM THE INBOARD FACE OF THE PORT VALANCE).
- (12) REMOVE THE ACCESS DOOR ON THE UNDERSIDE OF THE REAR NACELLE FAIRING AND REMOVE THE BOLTS SECURING THE AFT END OF EACH DOOR RAIL TO THE BULKHEAD (ACCESSIBLE FROM THE INSIDE FACES OF THE VALANCES).
- 13 DISCONNECT THE LOWER ENDS OF THE BRACING STRUTS TO THE MAIN SPAR FROM THE DOOR RAIL JUST FORWARD OF THE VALANCE.
- (14) REMOVE THE BOLTS SECURING THE FORWARD END OF EACH DOOR RAIL TO THE FIREWALL.
- (15) SUPPORT THE VALANCES AND DOORS AND REMOVE THE SCREWS SECURING THE VALANCES TO THE UNDERSIDE OF THE MAIN PLANE AND ENGINE RIBS

NOTE...
OPERATIONS NOT IN BRACKETS ARE NOT ILLUSTRATED

Fig. 8. Removal of undercarriage doors and valances

RESTRICTED

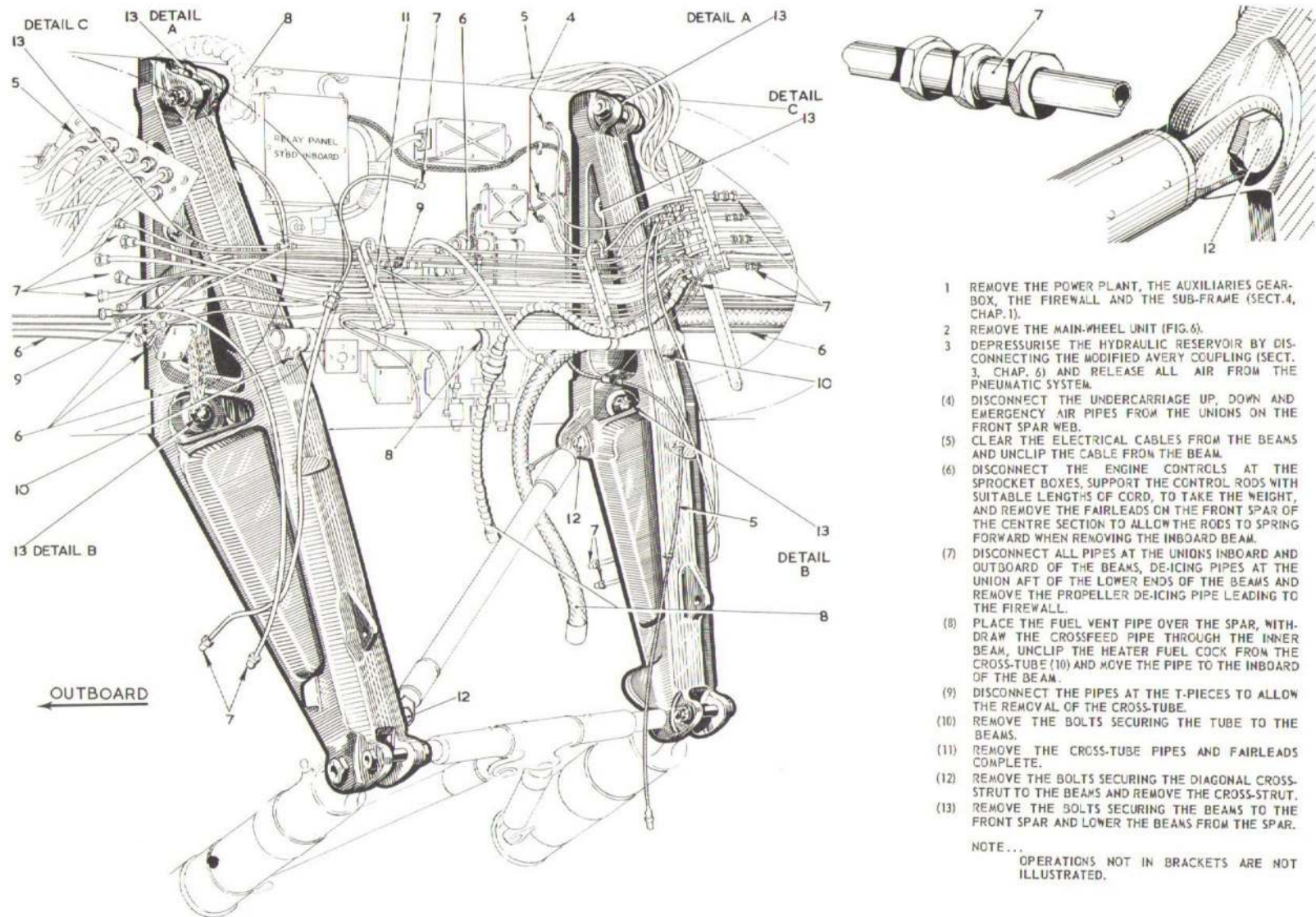

- 1 REMOVE THE POWER PLANT, THE AUXILIARIES GEAR-BOX, THE FIREWALL AND THE SUB-FRAME (SECT.4, CHAP.1).
- 2 REMOVE THE MAIN-WHEEL UNIT (FIG.6).
- 3 DEPRESSURISE THE HYDRAULIC RESERVOIR BY DISCONNECTING THE MODIFIED AVERY COUPLING (SECT. 3, CHAP. 6) AND RELEASE ALL AIR FROM THE PNEUMATIC SYSTEM.
- 4 DISCONNECT THE UNDERCARRIAGE UP, DOWN AND EMERGENCY AIR PIPES FROM THE UNIONS ON THE FRONT SPAR WEB.
- 5 CLEAR THE ELECTRICAL CABLES FROM THE BEAMS AND UNCLIP THE CABLE FROM THE BEAM.
- 6 DISCONNECT THE ENGINE CONTROLS AT THE SPROCKET BOXES, SUPPORT THE CONTROL RODS WITH SUITABLE LENGTHS OF CORD, TO TAKE THE WEIGHT, AND REMOVE THE FAIRLEADS ON THE FRONT SPAR OF THE CENTRE SECTION TO ALLOW THE RODS TO SPRING FORWARD WHEN REMOVING THE INBOARD BEAM.
- 7 DISCONNECT ALL PIPES AT THE UNIONS INBOARD AND OUTBOARD OF THE BEAMS, DE-ICING PIPES AT THE UNION AFT OF THE LOWER ENDS OF THE BEAMS AND REMOVE THE PROPELLER DE-ICING PIPE LEADING TO THE FIREWALL.
- 8 PLACE THE FUEL VENT PIPE OVER THE SPAR, WITHDRAW THE CROSSFEED PIPE THROUGH THE INNER BEAM, UNCLIP THE HEATER FUEL COCK FROM THE CROSS-TUBE (10) AND MOVE THE PIPE TO THE INBOARD OF THE BEAM.
- 9 DISCONNECT THE PIPES AT THE T-PIECES TO ALLOW THE REMOVAL OF THE CROSS-TUBE.
- 10 REMOVE THE BOLTS SECURING THE TUBE TO THE BEAMS.
- 11 REMOVE THE CROSS-TUBE PIPES AND FAIRLEADS COMPLETE.
- 12 REMOVE THE BOLTS SECURING THE DIAGONAL CROSS-STRUT TO THE BEAMS AND REMOVE THE CROSS-STRUT.
- 13 REMOVE THE BOLTS SECURING THE BEAMS TO THE FRONT SPAR AND LOWER THE BEAMS FROM THE SPAR.

NOTE...
OPERATIONS NOT IN BRACKETS ARE NOT ILLUSTRATED.

Fig.9. Removal of undercarriage beams (1)

RESTRICTED

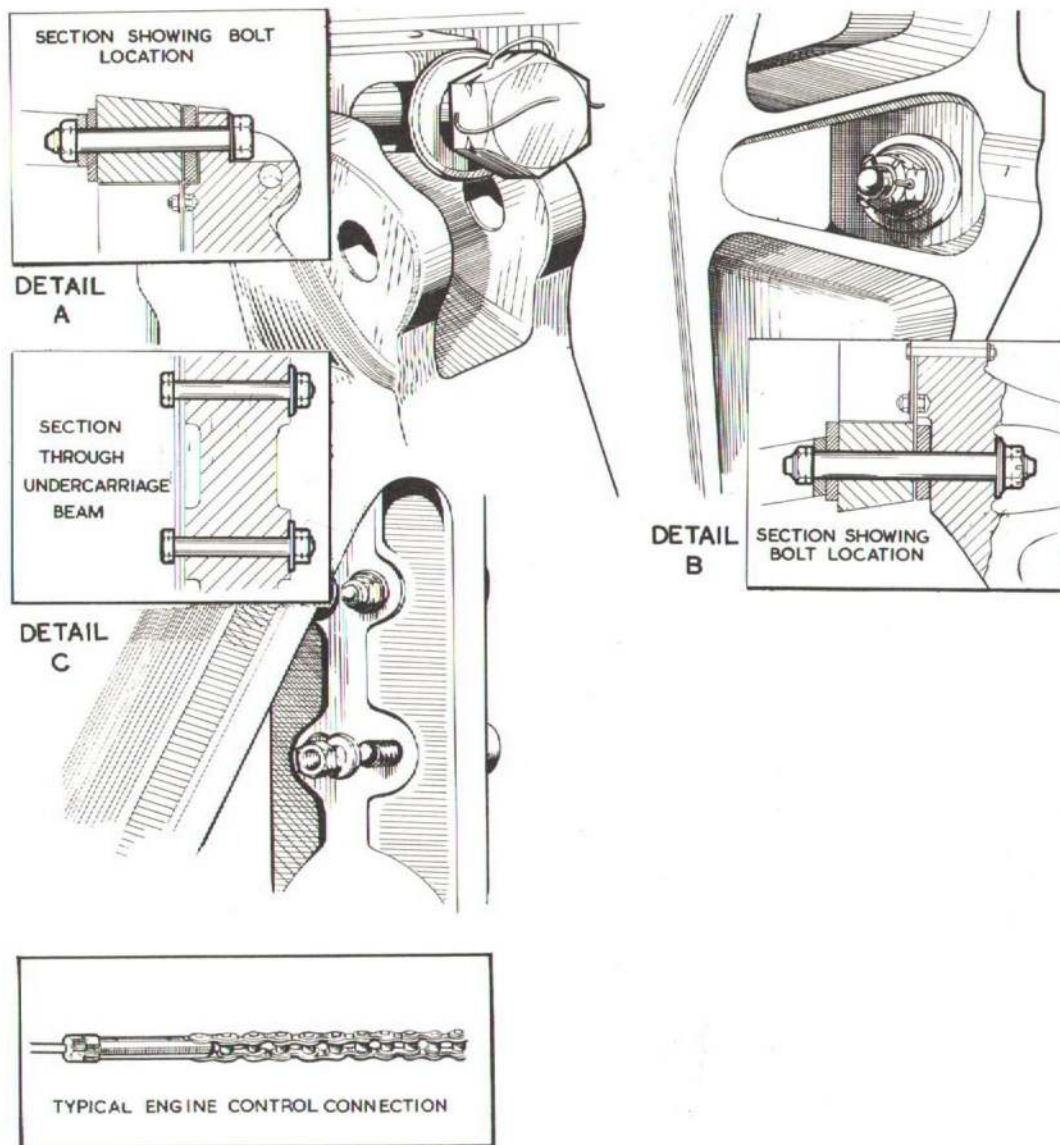

Fig.10. Removal of undercarriage beams (2)

the unit complete with the saddle caps and flanged bushes.

- (9) Slide the flanged bushes and saddle caps from the pivot shaft.
- (10) Remove the set screws, locating the flanged bushes in the saddle caps, remove the bushes and fit the set screws to the saddle caps for safe retention.
- (11) Remove the split pin and collar from the jack to retracting strut attachment pin (A.P.1803E, Vol.1, Sect.5, Chap.6, refers) and withdraw the attachment pin to release the jack piston rod.
- (12) Remove the bolt securing the upper end of the retraction strut to the aircraft structure.
- (13) Release the flexible pipes from the unions on the operating jack and remove the bolt securing the jack to the aircraft structure.

Main undercarriage doors and valances

33. This operation is illustrated in fig.7.

Undercarriage beams

34. Refer to fig.9 and 10

ASSEMBLY

35. Where specific instructions are not given, assembly is the reverse of removal. However, reference must be made to A.P.1803E, Vol.1.

Main-wheel unit shock-absorber panels

36. The information contained in Sect.2, Chap.2 of A.P.1803E, Vol.1, is amplified as follows:-

RESTRICTED

- (1) Jack the aircraft in the rigging attitude (Sect.2, Chap.4). Locate the horizontal strut assembly of the K-bracing between the attachment forks at the lower ends of the undercarriage beams and secure it by lightly screwing in the attachment bolt at one end.
- (2) Locate the upper lug of the relevant shock-absorber in the other attachment fork and screw in the attachment bolt. Remove the bolt temporarily fitted at the other side and similarly attach the other shock-absorber.
- (3) Place the special tool ST.992 with the hole at the lower end engaged with the screwed stud on the wheel side of one strut. Remove, if necessary, the locking plate from the stud for satisfactory engagement of the tool.
- (4) Exert a force on the lower end of the strut towards the other shock-absorber, adjust the special tool until its tapered end lightly engages with the lower edge of the bracing strut fitting.
- (5) Reverse the direction of the force on the lower end of the strut and check that a gap of 0.020 in. exists

between the tapered end of the tool and the bracing strut fitting.

- (6) Repeat the procedure for the other shock-absorber.
- (7) The struts forming the K-bracing are adjustable, but for normal re-assembly they should not be disturbed as the original panels are jig assembled. Should adjustment be necessary due to replacement of parts, the following check must be made.
- (8) Make a cross-trammel check between convenient points on the shock-absorber struts and, if necessary, adjust the bracing struts until the two measurements taken are the same. Note that it should not be necessary to adjust the struts with any other means than use of the fingers. If it is necessary to lengthen one bracing strut the other must be correspondingly shortened.
- (9) Check that the panel swings freely on its attachment bolts which must be well lubricated and, if necessary, adjust the bracing slightly to obtain this effect.
- (10) Lock the bracing struts by tightening the locking rings.

- (11) Connect the retraction struts and undercarriage doors and test the undercarriage for correct operation.

Tail-wheel unit

37. When fitting the tail-wheel unit pivot shaft in its bearing, first assemble the bearing sleeves to the bearing saddle caps, securing them with set screws. Then slide the sleeves and caps complete on to the pivot shaft and offer the unit up to the fixed halves of the pivot shaft bearings. Manoeuvre the bearing sleeves into the latter and fit the securing bolts to retain the caps and tighten evenly.

WARNING...

Failure to follow the above procedure will result in it being impossible to lubricate the pivot shaft bearings, as the lubrication holes in the bearing sleeves will not register with the grease nipple on each bearing saddle cap.

38. When fitting a tail-wheel unit shims must be fitted on the pivot shaft between the unit and the main bearings to give an end float of 0.010 to 0.015 in. with a minimum shim on either side of 0.005 in. Unused shims supplied with the unit must be stowed on the pivot shaft between the door operating lever and the main bearing



This file was downloaded
from the RTFM Library.

Link: www.scottbouch.com/rtfm

Please see site for usage terms,
and more aircraft documents.

