

Chapter 6 HYDRAULIC SYSTEM

LIST OF CONTENTS

DESCRIPTION AND OPERATION	Para.		Para.		Para.
Introduction	1	Selector switch	18	Tightening connections	37
Pumps	2	Control unit	19	Pipe leakage	38
Controls	3	Operation	20	Electrical failure	39
Emergency systems	4	Scanner circuit		Testing the pumps	40
Power circuit		Selector switch and indicators	21	Reservoir	41
Hydraulic oil reservoir	5	Control unit	22	Filling or topping up	42
Filler cap and drain	6	Operation	23	Pre-filling the jacks	43
Hand pump	7	Control micro-switches	24	Filling the system	44
Feed to pumps - suction	8	Windscreen wiper circuits		Bleeding	45
Delivery from pumps - main feed		Pilots' and air-bomber's	25	Normal bleeding	46
and by-pass	9	Front gunner's	25A	Bleeding after use of emergency	
Main return	10	Emergency air system		air	47
Pump couplings	11	Air storage bottles	26	Operation testing	48
Hydraulic services		Emergency air release valves	27	Adjustment of bomb doors	49
Alighting gear circuit		Emergency circuit operation		Windscreen wiper system bleeding	50
Selector switch	12	Alighting gear	29	Windscreen wiper setting	51
Control units	13	Flaps	31		
Operation	14	Bomb doors	32		
Flaps circuit		Scanner	33		
Selector switch	15				
Control unit	16				
Operation	17				
Bomb doors circuit					

REMOVAL AND ASSEMBLY

Flap jack	52
Scanner jacks	
Removal	53
Assembly	54
Other components and assemblies	55

SERVICING

Introduction	34
Faults in the system	35
External leaks	36

LIST OF TABLES

Table	Table
Hydraulic system components	1
Hydraulic system fault finding and rectification	2
	3
Operating times for hydraulic services	3

LIST OF ILLUSTRATIONS

Fig.		Fig.		Fig.	
Hand pump	1	Hydraulic system (5) bomb doors circuit	7	Hydraulic diagram (1) main feed and return	11
Hydraulic services - condensed diagram	2	Hydraulic system (6) scanner and tail-wheel circuits	8	Hydraulic diagram (2) alighting gear, windscreen wipers and flaps	12
Hydraulic system (1) main feed and return	3	Hydraulic system (7) windscreen wiper circuit	9	Hydraulic diagram (3) bomb doors and scanner	13
Hydraulic system (2) main-wheel circuit	4	Hydraulic system (8) emergency air system	10	Removal of flap jack	14
Hydraulic system (3) alighting gear control circuit	5	Hydraulic system (9) windscreen wiper circuit	10A	Removal of windscreen wiper	15
Hydraulic system (4) flaps circuit	6			Front gunner's control panel	16

DESCRIPTION AND OPERATION

Introduction

1. A high pressure hydraulic system is provided for:-

- (1) Retracting and lowering the main and tail-wheel units.
- (2) Lowering and raising the flaps.
- (3) Opening and closing the bomb doors.
- (4) Retracting and lowering the scanner and its associated cupola and intermediate fairing.
- (5) Operation of pilots' and air-bomber's windscreen wipers.

An independent system is provided to operate the front gunner's windscreen wiper. Fig.2 is a simplified diagram of the whole system. The location of components and the routing of all piping comprising the system are indicated in the relevant illustrations (fig.3 - 10). The complete diagram of the main system is illustrated in fig.11 to 13. Reference should be made to the A.P.1803 series for detailed information regarding the components used in the systems. The front gunners windscreen wiper system is indicated in fig.10A. Particulars of all components are listed in Table 1 and are numbered to correspond with the key numbers given in the illustrations.

Pumps

2. Two Integral two-stage pumps, each capable of delivering 3.4 gall. per min. maximum, at a working pressure of 2,200 p.s.i. are fitted. They are driven from No.3 and No.4 power unit accessory gearboxes. A Dunlop Maxivue pump, driven by an electric motor, is fitted to operate the front gunner's windscreen wiper.

Controls

3. The hydraulic services are controlled electrically or manually as follows:-

Electrically

- (1) Alighting gear control is effected by push-buttons on the pilots' fixed centre panel, labelled UNDER-CARRIAGE.
- (2) Flap and bomb door control is effected by gated lever-operated switches on the pilots' fixed centre panel.
- (3) Control of the retractable radar scanner cupola is effected by a rotary switch at the radar operator's station.
- (4) The front gunner's windscreen wiper is controlled electrically by a switch and a rheostat, labelled WINDSCREEN WIPER, WIPER SPEED respectively. Both these controls are mounted on the port side of the front gunner's control panel (fig.16).

Manually

- (1) The pilots' windscreen wipers are controlled by screw valves at the base of the pilots' blind flying panels, labelled WINDSCREEN WIPER.
- (2) The air-bomber's windscreen wiper is controlled by a screw valve on the air-bomber's starboard control panel, labelled WINDSCREEN WIPER.

Emergency systems

4. Emergency air systems are provided to lower the alighting gear or raise the scanner, to raise or lower the flaps in conjunction with the appropriate use of the

flaps selector switch and to open and close the bomb doors.

POWER CIRCUIT

Hydraulic oil reservoir

5. The oil reservoir is mounted on the front face of the front spar in No.4 power unit nacelle and is bushed and tapped for connections as follows:-

- (1) At the base, supply, by-pass and return connections.
- (2) At the top, pressurisation and vent connections.

The connection to which the air supply line from the pneumatic system is connected, incorporates a two-way cock to allow removal of the reservoir filler cap, without disconnecting the air supply.

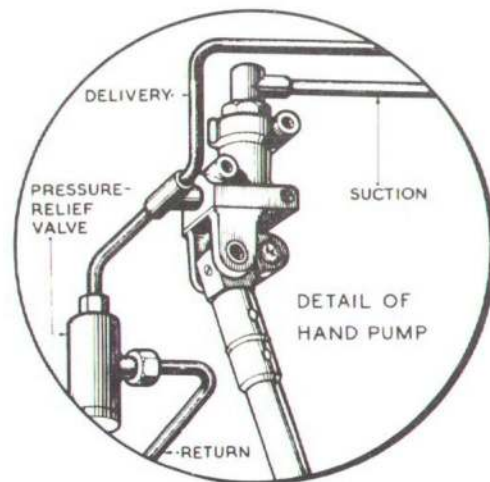

Fig.1. Hand pump

RESTRICTED

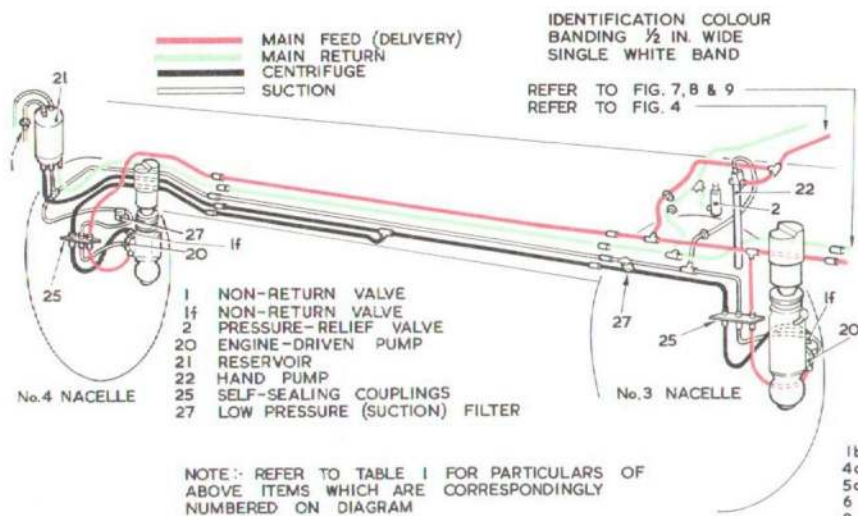

Fig. 3. Hydraulic system (1) - Main feed and return

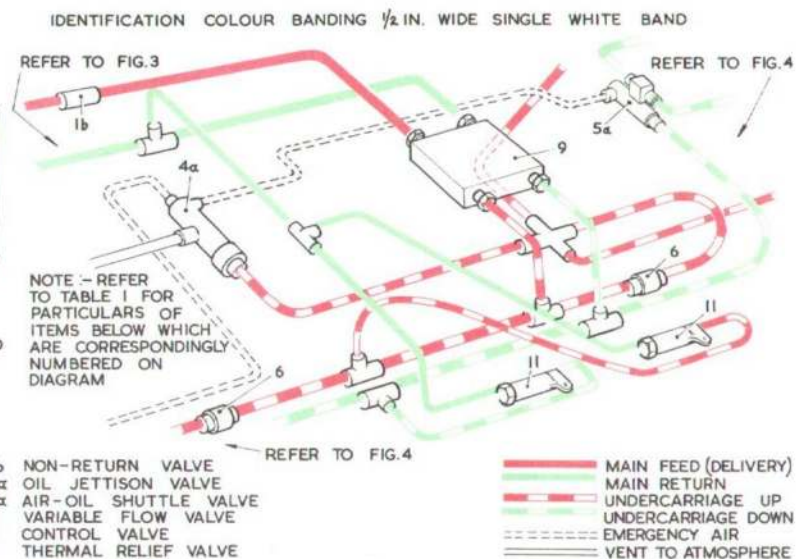

Fig. 5. Hydraulic system (3) - Alighting gear control circuit

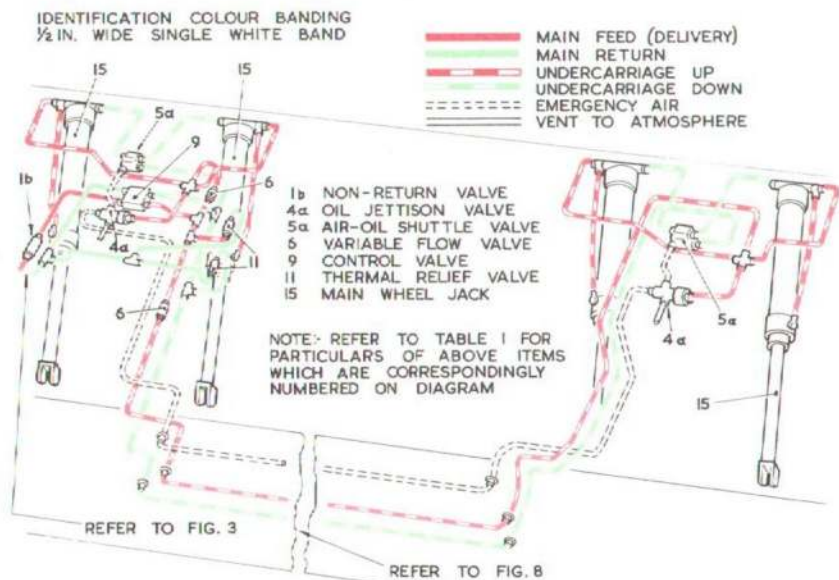

Fig. 4. Hydraulic system (2) - Main-wheel circuit

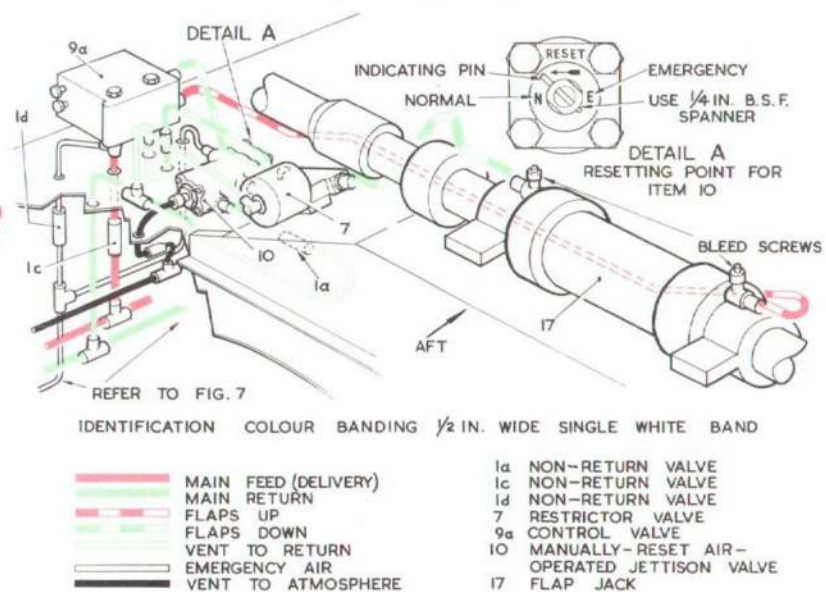

Fig. 6. Hydraulic system (4) - Flaps circuit

Normally, the handle of the valve is down to admit air for pressurisation. When the handle is raised, the air is shut off and the reservoir vented direct to atmosphere. It is, therefore, important to raise this handle before removing the filler cap. The vent connection incorporates a valve set to blow off at 17 - 20 p.s.i.

Filler cap and drain

6. The filler cap, which is inscribed FILL WITH U/C DOWN BOMB DOORS UP, is surrounded by a drip tray formed by an annular rim around the top of the reservoir. Spillage is drained from the drip tray by a pipe which has an outlet at the bottom of the nacelle. A removable filter, deep enough to accommodate a dipstick marked MAX. and MIN. and attached to the filler cap, is fitted into the filler opening. The filler cap, when off, is secured by a slave chain. A plate carrying filling instructions is attached to the reservoir body.

Hand pump (fig.1)

7. A hand pump, provided for ground servicing, is mounted on the aft face of the front spar behind No.3 power unit. Its use is normally limited to ground operation of the flaps and bomb doors, and it is accessible from the starboard wheel compartment. It is connected in parallel with the main pumps between the suction line and the main feed. A pipe, incorporating a pressure relief valve, is connected between the delivery line from the pump and the main return.

Feed to pumps - suction (fig.3)

8. Oil is fed to the two hydraulic pumps through a branched pipe from the suction union on the reservoir. A low-pressure filter is connected in each branch.

Delivery from pumps - main feed and by-pass (fig.3)

9. When no services are selected or operating, the pumps deliver oil along the by-pass line. The by-pass flow from both pumps is led into the forward end and then from the aft end back to the reservoir. When a service is selected, fluid is pumped along the main feed to the corresponding service control unit. A test point is provided in the main feed line and is located on the aft face of the front spar (fig.7).

Main Return (fig.3)

10. Oil returned from the jacks and windscreen wipers is piped into the main return and then to the central bottom connection of the reservoir. This connection communicates, inside the reservoir, with a short vertical perforated stack pipe which is closed at its upper end.

Pump couplings (fig.3)

11. Each pump is coupled to the three main pipes, described in preceding paragraphs, by self-sealing couplings. These couplings are mounted vertically through a horizontal panel secured to the sub-frame aft of the firewall in No.3 and 4 power unit nacelles. When it is necessary to disconnect the aircraft piping from the pumps, disconnection at these couplings prevents entry of air into the system.

HYDRAULIC SERVICES

Alighting gear circuit (fig.4, 5 and 8)

Selector switch

12. A two-button control, marked UP and DOWN, is situated on the pilots' panel with an adjacent red and green light indicator. A force of 40 lb. is required to operate the UP button when the air-

craft is in any other than an airborne condition. This safety lock is disengaged electrically at a predetermined airspeed by a pressure switch connected by piping between the pressure and the static piping of the A.S.I. system. When the DOWN push-button is pressed in, the scanner is automatically retracted from any of its down positions (Sect.5, Chap.1).

Control units

13. In the case of the main-wheel units, oil is fed to an electrically-operated control unit through a non-return valve. This unit opens the feed line to the selected ends of the jacks and permits oil to be expelled from the other ends of the jacks into the main return line. The oil feed line to this unit incorporates a non-return valve to prevent interaction between this and other circuits. The tail-wheel unit is controlled by a separate control valve fed direct from the main feed line. This control unit incorporates a thermal relief valve to mitigate the effects of thermal pressure changes.

Operation

14. When DOWN is selected, oil is fed by the main-wheel control valve along the two branches of the down piping to the anchored ends of the main-wheel jacks through two oil/air shuttle valves. Similarly, oil from the tail-wheel selector valve is fed to the down end of the tail-wheel jack, also through an oil/air shuttle valve. Oil expelled from each pair of main-wheel jacks is restricted by a variable flow valve, but the oil from the tail-wheel jack is returned unrestricted. When UP is selected, the flow is reversed, the oil to the main-wheel jacks now being passed freely by the variable flow valves. Emergency lowering of the alighting gear is described in a later paragraph.

Flaps circuit (fig.6)

Selector switch

15. Flap control is by a three-position

gated-lever switch acting in conjunction with a preselector drum switch (Sect.5, Chap.1) which ensures correct sequence operation of a flap restrictor valve (sub-para.3). The selector switch positions are marked UP, TAKE-OFF and DOWN. The drum switch is designed to:-

- (1) Direct the current from the selector switch to the up or down magnets of the control unit according to the attitude of the flaps at the time of selection.
- (2) Break the circuit when the correct position of the flaps has been reached after TAKE-OFF has been selected.
- (3) Energise the flap-restrictor-valve solenoid when the flaps are rising between the 'take-off' and the 'up' position.

Control unit

16. Oil is fed to the flap control unit through a separate non-return valve. The down line from the control unit passes to one end of the jack through the flap restrictor valve. The up line is connected directly to the other end of the jack. Mod.319 introduces flexible pipes to and from the jack to which they are coupled by banjo-type fittings.

Operation

17.

(1) If, when the flaps are 'down' or at the take-off position, the control switch lever is moved to UP, the control unit admits oil to the 'up' side of the single jack. When the flaps reach the 'take-off' position (if selected from 'down') the drum switch, rotated by a linkage from the flap-operating tube inside the fuselage, energises the restrictor valve which then further restricts the normally restricted flow from the jack. This retards the speed of retraction of the flaps, between the 'take-off' and 'up' to a safe figure. The operation from 'up' to down is

normal, but, if TAKE-OFF is selected, the drum switch cuts the control unit out when this attitude is reached, causing the flaps to remain there.

(2) Manual operation of the flap control valve can be effected by the use of two small push-buttons on the forward face of the control unit should the electrical circuit fail. The buttons are reached through an opening in the forward face of the cover over the starboard half of the flap operating gear cover in the fuselage rear centre section. An instruction label is fixed to the cover above the opening and inscribed MANUAL OPERATION OF FLAP CONTROL VALVE, TOP BUTTON - FLAPS UP, LOWER BUTTON - FLAPS DOWN. The buttons are spring-loaded to off, and therefore, the button being used must be kept depressed until the desired operation of the flap jack is complete. Under these conditions, the extra restriction normally present in the flaps restrictor valve between 'take-off' and 'up' will be absent causing the flaps to rise very quickly when raised over the range.

(3) Operation by emergency air is described in para.31.

Bomb doors circuit (fig.7)

Selector switch

18. A three-position lever control switch, similar to that controlling the flap circuit and labelled OPEN and CLOSED, is mounted on the pilots' panel.

Control unit

19. In this circuit the control unit has one outlet blanked off. The other outlet is piped through an oil/air shuttle valve to the anchored ends of the jacks.

Operation

20. The bomb door jacks are operated by differential pressure. When the switch is set to OPEN, the control unit feeds

oil to the anchored ends of the jacks. The cross-sectional area of the piston head is greater than that of the piston-rod side and the oil from this latter end of each jack is forced round through the control unit to the anchored ends of the jacks and supplemented by further oil from the control unit. When CLOSED is selected, the control unit opens the anchored end lines to the return line and feed to the piston-rod ends of the jacks is then automatic, as oil passes out of the anchored ends to the return line.

Scanner circuit (fig.8)

Selector switch and indicators

21. A rotary switch on a scanner-control and call-box panel, mounted on the radar operator's lower shelf, has four positions inscribed, UP, 1ST SRCH, 2ND SRCH and ATTK and energises the solenoids of an electrically-operated control unit in conjunction with a selector circuit (para. 24 and Sect.5, Chap.1). Four doll's-eye indicators on the panel are labelled, UP, SEARCH NO.1, SEARCH NO.2 and ATTACK, and another indicator labelled, A.S.V. RETRACTED is mounted on the pilots' panel. In addition, an electrical interlink circuit between the alighting gear and scanner control circuits ensures that the scanner is retracted, irrespective of the position of its selector switch, when the DOWN push-button on the alighting gear control switch is pressed in. After the scanner has been retracted by this means, a warning light on the panel illuminates an inscription on the lamp glass which reads RESET CONTROL SWITCH UP.

Control unit

22. This unit is similar to that used to control the flaps. The down line from the unit is led to the upper end of the starboard operating jack and incorporates a connection to a jettison valve and another to the outlet end of a pressure-relief valve. The up line incorporates

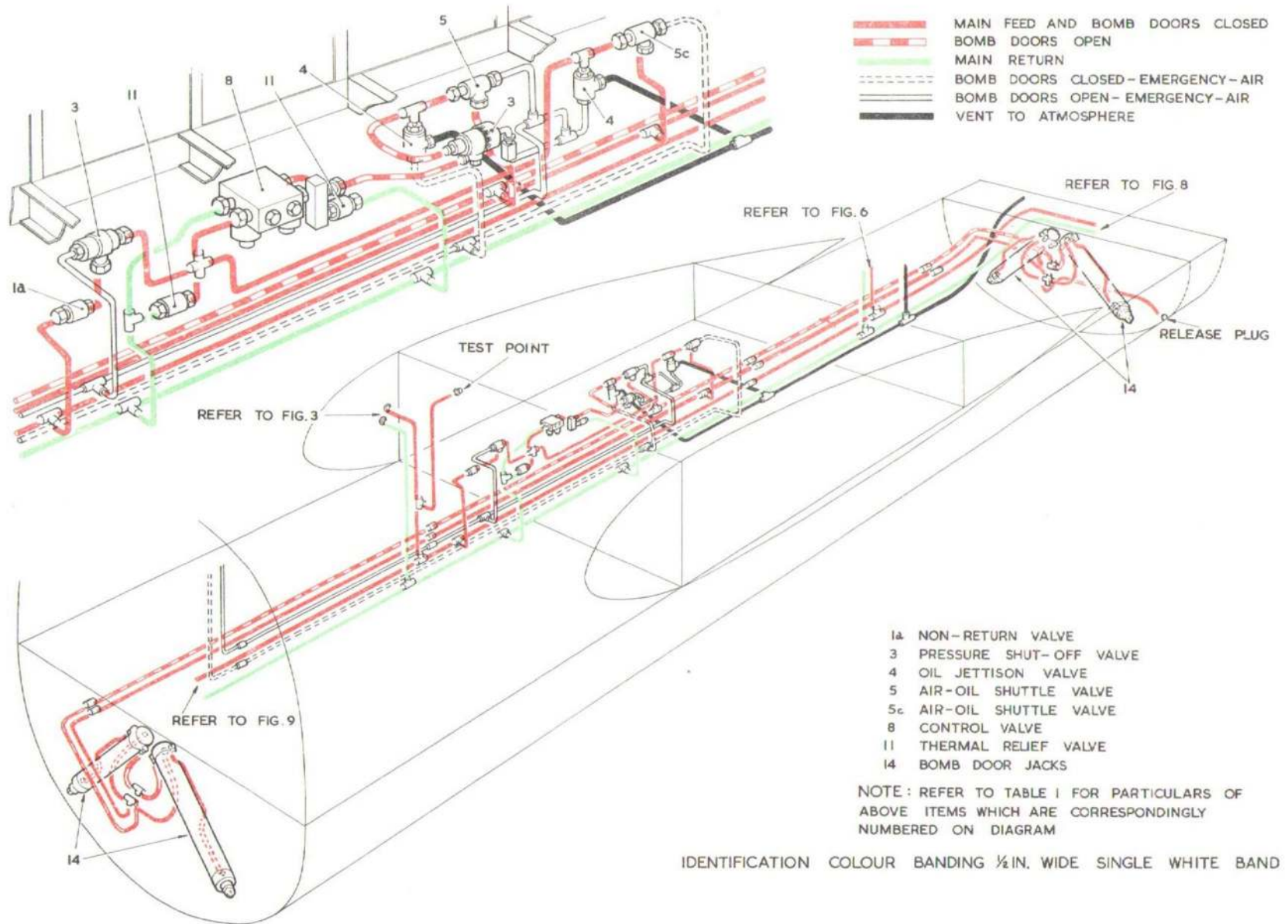

Fig. 7. Hydraulic system (5) bomb doors circuit

RESTRICTED

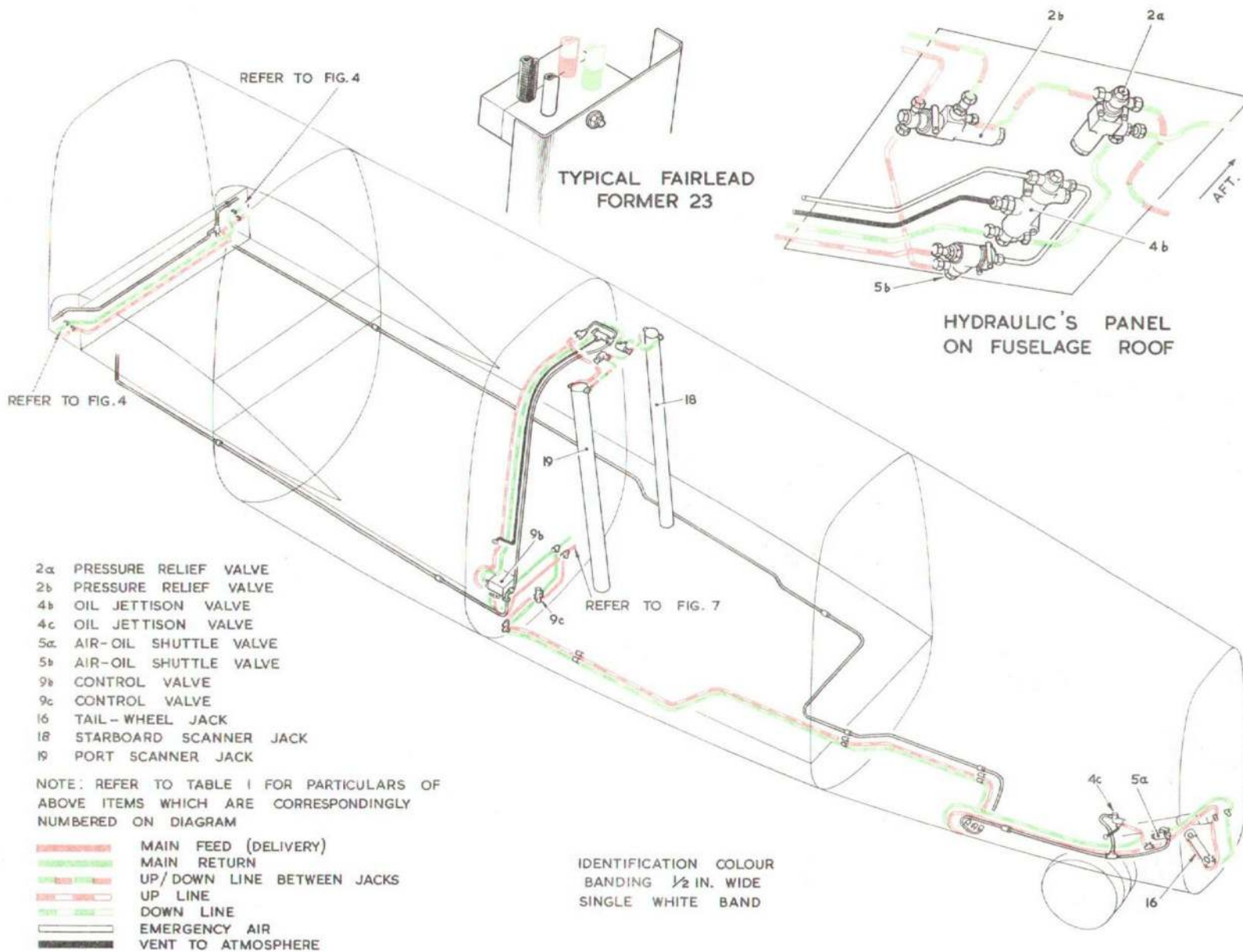

Fig. 8. Hydraulic system (6) scanner and tail wheel circuits.

RESTRICTED

a shuttle valve and is connected to the inlet end of a pressure-relief valve and to the lower end of the port jack. The upper end of this jack is connected by piping to the lower end of the starboard jack. The remaining ends of the two relief valves are connected to this pipe. The jacks are arranged with their piston-rods static; the jack cylinders are the moving portions.

Operation 23.

(1) When down is selected, oil passes along the pipe to the down connection on the starboard jack. Oil expelled from this jack is fed to the down connection of the port jack and causes series operation of the jacks. The relative capacities of the two jacks is arranged to give equal operation under these conditions. Expansion or contraction of the oil contained in the closed circuit occasioned by this arrangement is overcome by the action of the two relief valves. When UP is selected, the operation of the two jacks is reversed.

(2) Manual control of the valve can be effected by the use of two push-buttons as in the case of the flap control valve. An inscription painted on the inside of the fuselage wall between formers 23 and 24, about 10 in. above floor level reads:-

SCANNER MANUAL CONTROL
TOP BUTTON - UP
BOTTOM BUTTON - DOWN
USE ONLY ON ELECTRICAL FAILURE

with an arrow pointing to the control unit, which is at floor level forward of former 23. The push-buttons are accessible through openings in the aft face of the valve guard.

(3) Ground operation

WARNING...

Operation of the scanner jacks whilst there is any possibility of any personnel

being at work inside the radome, or its associated fairing, may result in serious injury.

In view of the above WARNING, the individual in charge of personnel detailed to work in the scanner well, below the floor, must ensure that the No.1 fuse is removed from fusebox ZZ at former 12 by a competent tradesman, and retain it during all periods whilst personnel are working in the scanner well. Should it be necessary to operate the scanner jacks during these periods, the manual selector buttons, described in sub-para.(2) above, are to be used in conjunction with the hand pump in the starboard wheel compartment.

(4) An emergency air system is also provided.

Control micro-switches

24. On the aft face of the port jack are

six micro-switches mounted on four clip assemblies between which are fitted three lengths of conduit channel. The switches are positioned to control the operation of the jacks in accordance with any position of the control switch as follows:-

- (1) UP - one micro-switch near the top of the jack outer casing.
- (2) 1ST SEARCH - two micro-switches about half way down the casing.
- (3) 2ND SEARCH - two micro-switches about 8 in. below those in (2).
- (4) ATTACK - one micro-switch near the lower end of the casing.

The jacks are housed inside hollow rams which slide with the cylinders inside the outer casings. The micro switch plungers protrude through holes in the port outer casing and are depressed by a chamfered annular ring at the top of the hollow ram as it passes them.

IDENTIFICATION COLOUR BANDING
½ IN. WIDE SINGLE WHITE BAND

23 SCREW VALVE
24 WINDSCREEN WIPER

NOTE:- REFER TO TABLE I FOR PARTICULARS OF ABOVE ITEMS WHICH ARE CORRESPONDINGLY NUMBERED ON DIAGRAM.

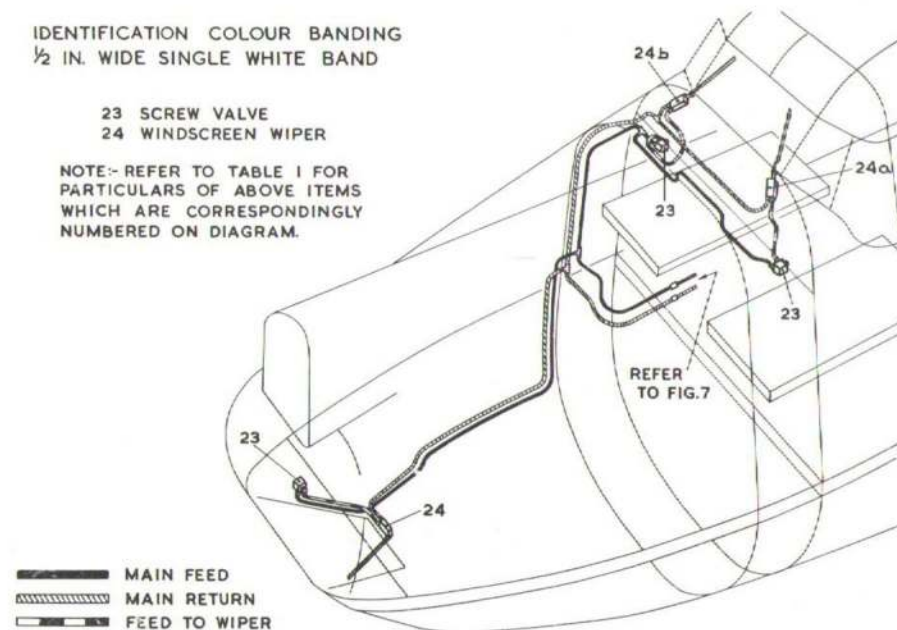

Fig.9. Hydraulic system (7) windscreen wiper circuit

RESTRICTED

TABLE 1

Hydraulic system components

Item	Description	Part No.	Ref.No.	Item	Description	Part No.	Ref.No.
1	Non-return valve	D.2137Y	27Q/636	14	Bomb door jack	1.00535.001 or A.8274Y Mk.A	27Q/- 27Q/1477
1a	Non-return valve	U.M.C.706	27W/10				
1b	Non-return valve	U.M.C.708	27W/12				
1c	Non-return valve	D.278Y	27Q/489			1.00535.002 or A.8274Y Mk.B	27Q/- 27Q/1478
1d	Non-return valve	D.127Y	27Q/724				
1e	Non-return valve	D.277Y	27Q/486	15	Main-wheel jack	1.001108.001 1.001108.002	27Q/- 27Q/-
2	Pressure relief valve	O.084YA20	27Q/-				
2a	Pressure relief valve	1.00084.005	27Q/-	16	Tail-wheel jack	1.01069.001	27Q/70600
2b	Pressure relief valve	1.00084.006	27Q/-	17	Flap jack	A.8272Y	27Q/1481
3	Pressure shut-off valve	A.2303Y	27Q/732	18	Scanner jack (starboard)	E.8275Y Mk.B	27Q/1485
4	Fluid jettison valve	C.305Y Mk.C	27Q/634	19	Scanner jack (port)	E.8275Y Mk.A	27Q/1484
4a	Fluid jettison valve	C.200Y Mk.B	27Q/723	20	Hydraulic pump	Integral Type 116 Mk.2	37J/1217
4b	Fluid jettison valve	C.3750Y Mk.C	27Q/1111				
4c	Fluid jettison valve	C.3750Y Mk.B	27Q/856				
5	Air/oil shuttle valve	C.1887Y	27Q/638	20a	Hydraulic pump (Maxivue Type)	A.C.10230	27WW/107
5a	Air/oil shuttle valve	C.9981	27Q/591	21	Oil reservoir	A.4581Y	27Q/964
5b	Air/oil shuttle valve	D.1647Y Mk.F	27Q/967	22	Hand pump	U.M.C.501	27W/1
5c	Air/oil shuttle valve	C.2898Y	27Q/725	23	Screw valve	A.C.O.7470	27WW/248
6	Variable flow valve	D.6306Y	27Q/1160				
7	Flap restrictor valve	1.01324.001	27Q/1102	24	Windscreen wiper (air bomber)	A.C.11642	27WW/240
8	Bomb door control valve	1.00042.012	27Q/-	24a	Windscreen wiper (first pilot)	A.C.11046	27WW/199
9	Alighting gear control valve	C.8389Y or 1.00042.013	27Q/1495 27Q/-	24b	Windscreen wiper (second pilot)	A.C.11048	27WW/200
9a	Flaps control valve	C.6602Y Mk.U	27Q/1103	24c	Windscreen wiper (front gunner)	A.C.M.21808	27WW/-
9b	Scanner control valve	C.6602Y Mk.E	27Q/993	25	Self-sealing coupling	A.V.A.50C	27M/-
9c	Tail-wheel control valve	C.6731Y Mk.A	27Q/1199	25a	Self-sealing coupling	A.V.A.52D	27M/-
10	Change-over jettison valve	C.4046Y	27Q/986	25b	Self-sealing coupling	A.V.A.50F	27M/-
11	Thermal relief valve	U.M.C.632	27W/5	26	Flexible pipe (delivery)	171/Q1433	26FP/1625
12	Air release valve	C.9955 Mk.C	27Q/722	26a	Flexible pipe (suction)	8/Q1304	26FP/855
13	Emergency air storage bottle	-	6D/732	26b	Flexible pipe (centrifuge)	41/Q1358	26FP/854
				27	Low pressure filter	E.60L/1/7915	27B/1408

◀ A.C.11046 is the port wiper motor only; the associated wiper arm is A.C.M.23048, Ref.No.27WW/- and the wiper blade A.C.M.22164/10, Ref.No.27WW/-.

▶ A.C.11642 is the wiper motor only; the associated wiper arm is A.C.M.16190, Ref.No.27WW/198 and the wiper blade A.C.M.15590/15, Ref.No.27WW/-

◀ A.C.11048 is the starboard wiper motor only; the associated wiper arm is A.C.M.23050, Ref.No.27WW/- and the wiper blade is the same as the port wiper blade.

▶ A.C.M.21808 is the wiper motor only; the associated wiper arm is A.C.M.21810, Ref.No. 27WW/- and the wiper blade A.C.M. 19552/14, Ref.No. 27WW/-

RESTRICTED

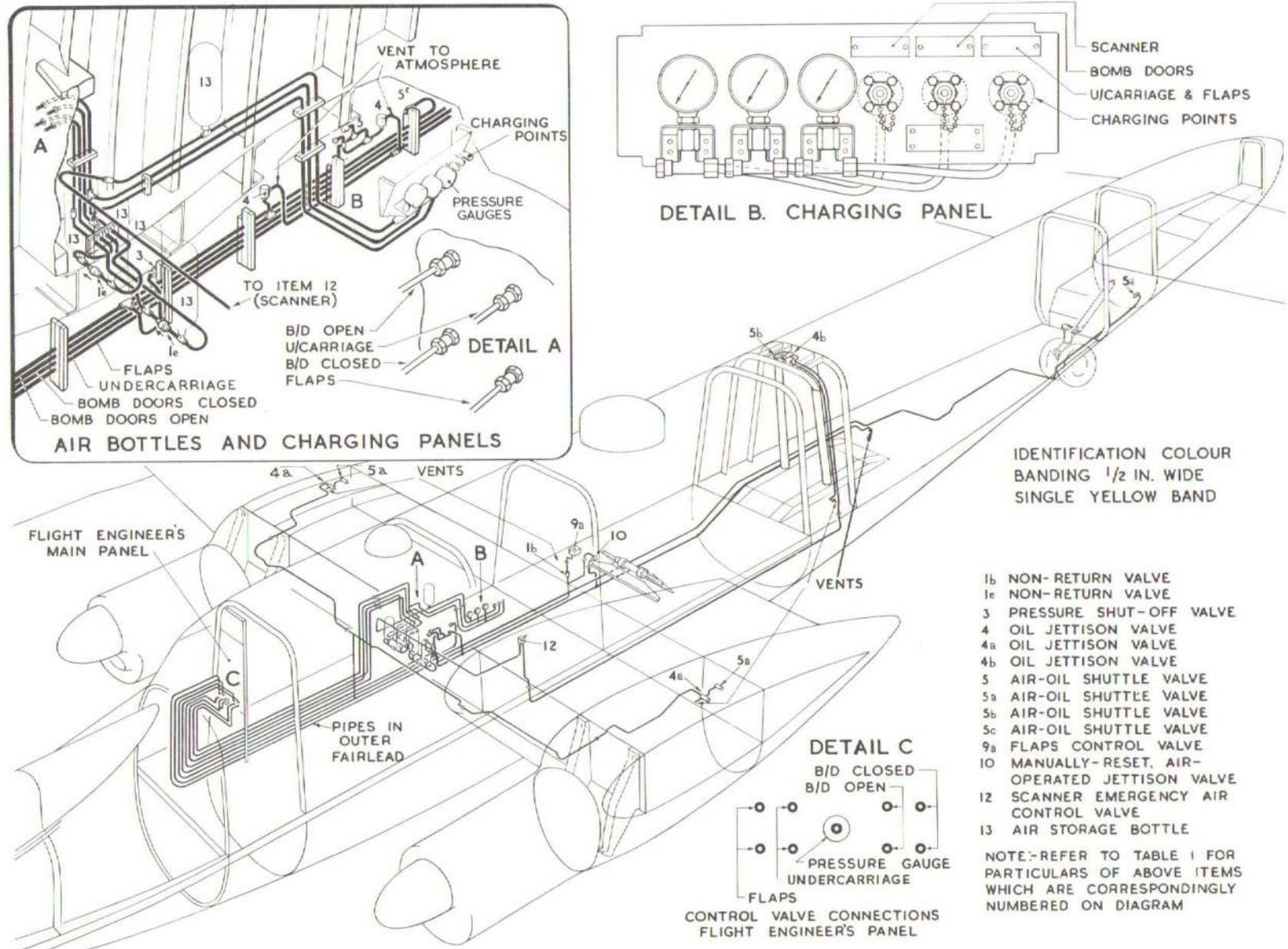

Fig.10. Hydraulic system (8) emergency air system

RESTRICTED

WINDSCREEN WIPER CIRCUITS (fig.9 and 10A)

Pilots' and air-bomber's

25. Three windscreen wipers are fitted in this circuit, two for the pilots' and one for the air-bomber. Two screw valves (para.3) control the pilots' windscreen wipers. A screw valve (para.3) controls the air-bomber's windscreen wiper. The pilots' and air-bomber's wiper circuit is fed from the main hydraulic feed. Oil passing through the wipers is returned to the reservoir through the main return line. Routing of the circuit to the pilots' windscreen wipers is from the main feed supply in the bomb bay, passing forward along the starboard side of the fuselage to a tee-connection at former F. The feed is then directed upwards on the aft face of former F to the pilots' control valves, then to the windscreen wiper head mounted at the base of the pilots' windscreens. From the tee-connection at former F, a feed line is taken down to the floor, then forward to the air-bomber's control valve, then on to the windscreen wiper head, mounted at the base of the air-bomber's windscreen.

Front gunner's

25A. The front gunner's wiper circuit is fed from a Dunlop Maxivue pump. The windscreen wiper control is effected by a switch and a rheostat (para.3). The pipelines from the pump to the wiper head are alternately feed and return with each stroke of the pump pistons. The routing of the circuit is from the pump, mounted on the starboard side of the nose section, just above the floor, forward of former L, upwards to a coupling at the top of former L. The lines then pass forward to the front gunner's control valve. From the control valve, the lines pass to the windscreen wiper head, mounted at the base of the front gunner's windscreen.

EMERGENCY AIR SYSTEM

Air storage bottles (fig.10)

26. Air is stored at 1,800 p.s.i. in five bottles, four of which are mounted on a rack under the sonobuoy operator's seat base and front spar step in the fuselage intermediate centre section, the fifth being mounted above the floor on the starboard side of the fuselage between formers 8 and 9. Three pressure gauges and three charging points are fitted on a panel under the floor and are accessible from the bomb compartment at former 10. A further pressure gauge at the bottom of the flight engineer's main panel indicates the air pressure available for lowering the alighting gear. Two of the charging points each supply two of the four bottles on the rack and one supplies the single bottle. One pair of bottles provides air for operating the bomb doors, the other pair is for the alighting gear and flap systems and the single bottle on the starboard side of the fuselage is for the scanner system.

Emergency air release valves

27. Two pairs of emergency air release valves at the bottom of the flight engineer's main panel control the emergency air operation of the bomb doors, undercarriage and flaps. A single emergency air release valve is mounted on a bracket at the port side of the scanner control switch at the radar operator's station.

Bomb doors

These are operated by the pair of levers on the port side of the panel. Of this pair the left hand lever is labelled OPEN and the right hand one CLOSED. A slide pin, incorporating a lug, forms a manually-operated catch which holds the two levers OFF. Movement of the pin to one side frees the lever on the other side only, thus preventing the use of both levers simultaneously. When

the slide pin is in its neutral position, it locks both levers.

Alighting gear and flaps

The left hand lever of the starboard pair is marked UNDERCARRIAGE and the right hand one FLAPS. Both levers have safety-catch pins which must be withdrawn before the levers can be operated. Operation of the flaps lever admits air to the feed union of the flaps control unit and the correct selection of the flaps selector switch must be made to obtain the desired movement of the flaps.

Scanner

The lever at the left-hand side of the scanner control switch is used to fully retract the scanner only and is labelled SCANNER EMERGENCY AIR. Before using this control to retract the scanner, set the scanner selector switch at the UP position to prevent loss of oil from the system which might empty the reservoir and cause damage to the hydraulic pumps.

28. It is necessary to hold each emergency lever down whilst the relevant service is being used, since all the levers are spring-loaded to OFF.

(1) Undercarriage - until the indicator shows LOCKED DOWN.

(2) Flaps - until the indicator shows that the desired flap position has been obtained.

(3) Bomb doors - until they are fully open or closed. A check may be made through the inspection door in the forward bomb compartment bulkhead.

(4) Scanner - until the full retraction of the scanner is indicated by the upper indicator on the radar operator's scanner control panel or the indicator on the pilot's panel.

RESTRICTED

EMERGENCY CIRCUIT OPERATION**Alighting gear**

29. The system lowers the alighting wheels and locks them down, regardless of the position of the undercarriage selector switch, and it is impossible to retract them again once the emergency system has been used. It is important, however, that the selector switch is moved to the DOWN position before lowering the alighting gear by emergency air, in order to prevent air leakage allowing the wheels to retract when the aircraft is on the ground. Selection of down also causes the scanner to retract provided the scanner hydraulic circuit is serviceable (Sect.5, Chap.1)

30. When the emergency air valve is opened, air from one of the two associated cylinders (which are separated by a non-return valve) flows to, and opens, the fluid jettison valve for each of the three wheel units. The air also passes to the three alighting gear shuttle valves (fig.5) which admit the air to the down sides of the jacks and shut off the oil from the down lines. As the wheel jacks are extended, the displaced oil is expelled from the three jettison valves. Oil from the tail-wheel jack is returned to the reservoir.

Flaps

31. Opening of the relevant emergency air valve admits air from both of the associated cylinders to the flap control unit and selection of the desired flaps attitude must be made by use of the flap selector switch. A change-over air-operated jettison valve operated by the emergency air then allows the oil, which is normally returned to the reservoir, to be jettisoned.

WARNING...

Whilst it is necessary to reset the air-

operated change-over jettison valve during the bleeding necessary after emergency air operation of the flaps, this valve must not be reset until all air has been removed from the flaps circuit. If this valve is reset and a selection is then made before all compressed air in the system has been bled off, the air will be directed through the flaps selector valve to the reservoir which will then, in all probability, burst and damage surrounding structure (refer to para.47, sub para.(4)).

Bomb doors

32. The two bottles of this system are separated by a non-return valve, which allows air from only one bottle to open the bomb doors whilst air from both is available to close them. Operation of either admits air to the system as follows:-

- (1) The OPEN lever admits air to a shuttle valve from which it passes to the open line. At the same time, air is fed to, and opens, a jettison valve in the closed line. As the jack pistons are forced down, the displaced oil is expelled from the air-operated, change-over jettison valve.
- (2) The CLOSED lever admits air to a similar system and as the jack pistons are forced up, the displaced oil is expelled from a jettison valve.

Scanner

33. When the emergency air control valve at the radar operator's station is opened, air from the associated bottle

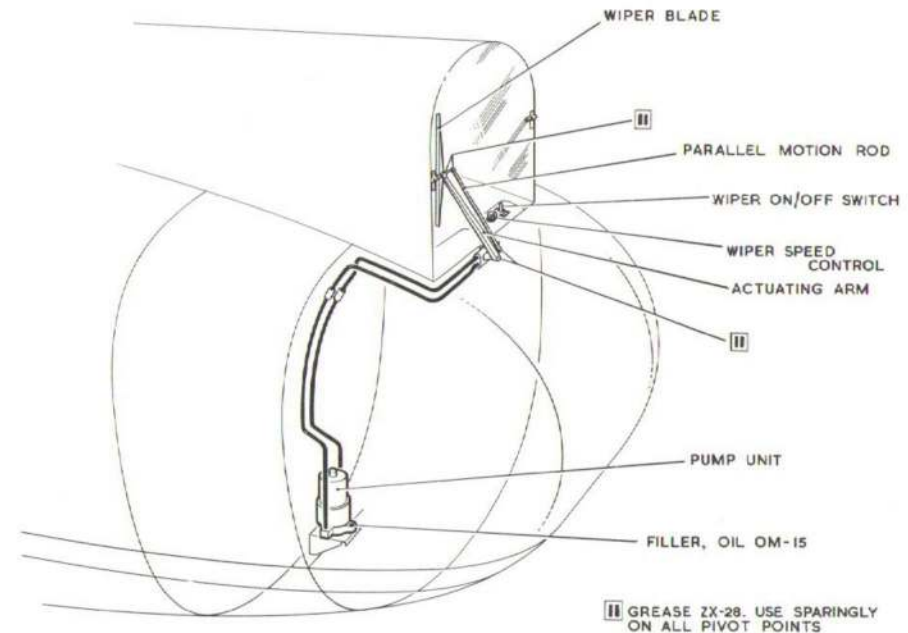

Fig.10A. Hydraulic system (9) windscreen wiper circuit

RESTRICTED

opens a jettison valve and operates a shuttle valve. The air passes from the shuttle valve along the up line to the scanner jacks and the oil consequently displaced from the starboard jack is

expelled through the jettison valve. A label, fitted at the top of the radar operator's scanner control panel inboard of the intercom. call box, is inscribed **SELECT SCANNER UP BEFORE USING**

EMERGENCY AIR and an arrow which points from this label to the emergency air control valve lever is painted on the panel over the call box.

SERVICING

WARNING...

During servicing operations entailing operation of the scanner jacks whilst there is any possibility of personnel being at work in the scanner well, below the floor, the instructions contained in para.23 (3) must be carried out.

Introduction

34. In all servicing operations absolute cleanliness is essential. Clean oil (Leading Particulars) only must be used when filling or topping up and the containers, funnels, etc., used for holding the fluid or for the reception of drained fluid, must be scrupulously clean. After a container has been carefully cleaned it must be swilled out with a small quantity of the clean oil which must be then discarded. Whenever pipes are disconnected, the ends must be suitably covered or sealed to prevent entry of dirt. Whenever drain plugs or other components are removed, they must be carefully examined to ensure that they are free from dirt before assembly. New pipes or components must be thoroughly flushed out with the type of oil used in the system before they are fitted.

FAULTS IN THE SYSTEM

35. Faulty operation of the system will be due to one of the following defects:-

- (1) Defects in the hydraulic circuit.
- (2) Faults in the electrical control system.
- (3) Mechanical faults.

Faults can usually be traced by observation of the behaviour of the whole system during which the locality of the fault must be established before removing or dismantling any components for rectification.

NOTE...

It is not permissible to use the aircraft electrical supply during ground testing of the systems. An external ground supply must be used.

External leaks

36. If the system is kept clean, the source of any external leakage is readily denoted by localised seepage. Such seepage normally occurs at pipe connections, glands, jack piston-rods, etc. In some cases, namely, olive-type unions or belled pipe connections, seepage may be due to a slackness of the union.

Tightening connections

37. Tightening of a union, particularly in the case of rubber sealed joints, must not be carried out unless permitted by the maintenance notes applicable to the unit concerned (A.P.1803).

Pipe leakage

38. This is normally the result of abrasion caused by a pipe chafing against a structural member or another pipe. When fitting or replacing a length of pipe, it must be securely clipped to all points of the structure with which it is liable to make contact.

Electrical failure

39. Complete failure of electrically

controlled parts of the system, or of any particular electrically controlled circuit, may be the result of a fault in the electrical system (Sect.5, Chap.1). If hydraulic pressure can be built up in the parts of the system affected by use of the pumps, electrical failure is indicated. The exact nature of the failure to operate must be noted to enable the correct relevant parts of the electrical system to be investigated.

Testing the pumps

40. The only satisfactory way to check the functioning of the pumps, without removing them from the aircraft, is to test them independently, which necessitates running No.3 and 4 power units separately at the same speed. Operate the flaps and bomb doors by each pump in turn, checking the respective operating times. A pressure test point is provided on the aft face of the front spar in the fuselage near the starboard side (fig.7).

RESERVOIR

41. The reservoir is mounted on the forward face of the front spar in No.4 power unit nacelle and is accessible after removing the top and outer cowling panels of the firewall. The reservoir must always be depressurised before disconnecting any part of the system, except when priming the pumps.

Filling or topping up

42. When filling or topping up the reservoir, the aircraft must be resting on its

TABLE 2
Hydraulic system fault finding and rectification

Symptom	Probable fault	Remedy
All services inoperative	Complete loss of pressure due to :— (1) Lack of oil (2) Stoppage in suction line from reservoir (3) Failure of pumps to deliver—various reasons, stoppage or breakdowns or both (4) Electrical failure	Fill system First test hand pump to eliminate cause (3). Test flow from suction line to outboard pump. Remove stoppage if present. Investigate, clear and fit new pumps, if necessary. Refer to Sect. 5, Chap. 1.
One service inoperative	Electrical failure on service control valve circuit	Refer to Sect. 5, Chap. 1.
Slow operation of all services	Partial loss of pressure due to :— (1) Failure of one pump (2) Worn pump(s) (3) Partial stoppage in suction line (4) Partial stoppage in return line ; this will restrict evacuation of jacks	Test each pump by running relevant engine, fit new pump Fit new pump(s). Test for and clear stoppage. Test for and clear stoppage.
Slow operation of one service	Full pressure on service, fault due to :— (1) Side load on a jack piston due to mal-alignment (2) Mechanical interference or foreign matter between two moving parts (3) Excessive friction due to tight gland (4) Dry bearings, particularly flap hinges	Re-align component. Investigate and clear. Check and remedy. Lubricate.
Creeping of a service when no selection has been made	Oil leakage at jack(s), or, more probably, at the control valve	Inspect components or remove and test. Repair or renew.
Operation slow and/or jerky ; backlash or sponginess at hand pump	Air in system due to oil loss, incorrect bleeding or filling	Top up and bleed.
External leakage	Faulty connections	Tighten connections and, if necessary, fit new seal, olive or coupling.

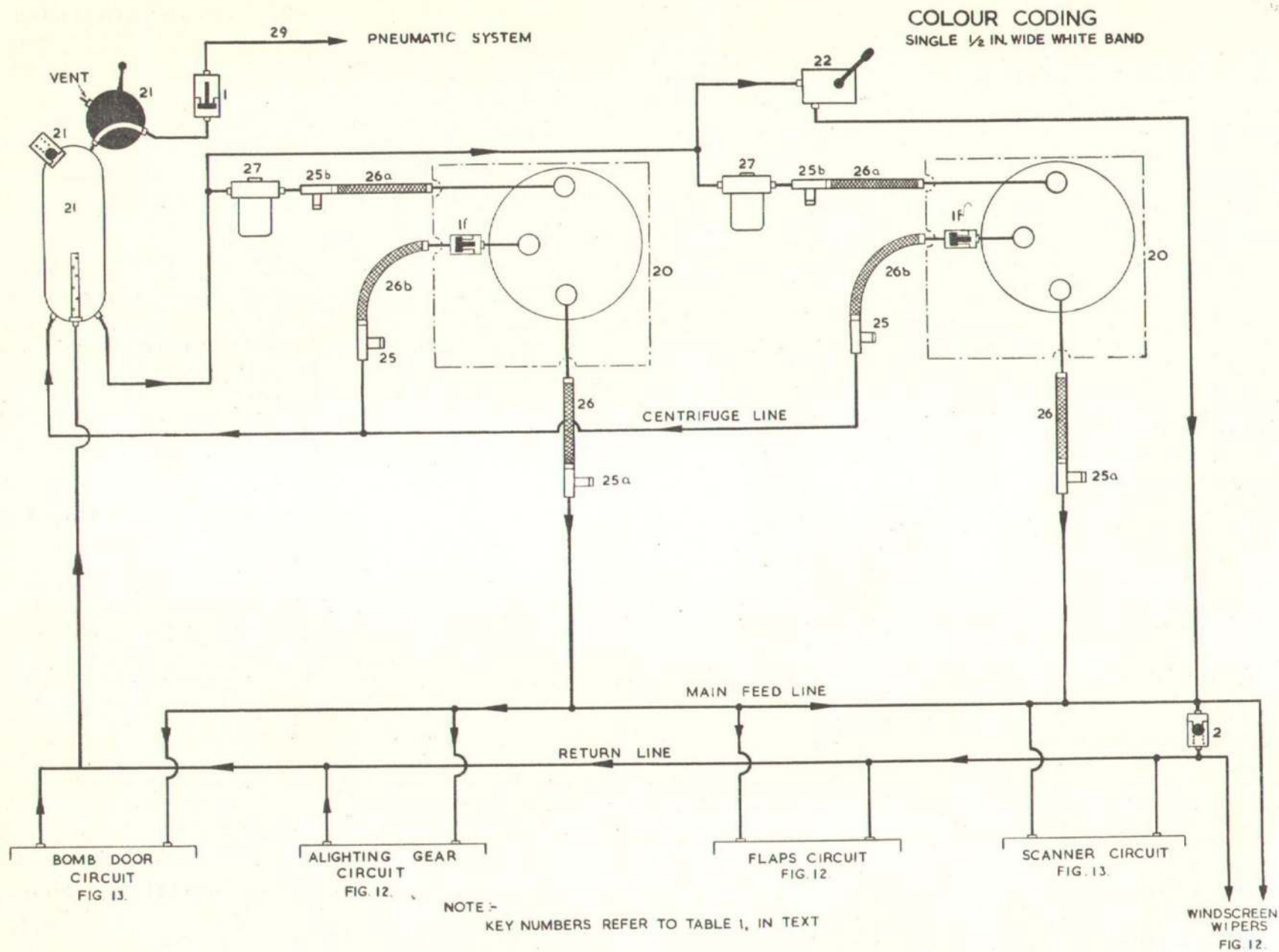

NOTE -
KEY NUMBERS REFER TO TABLE 1, IN TEXT

Fig. 11. Hydraulic diagram (I) main feed and return

wheels with the bomb doors closed, flaps up and the scanner fully retracted. Turn the handle of the depressurisation cock at the top of the reservoir to the up position to cut off the pneumatic supply and vent the reservoir, before removing the filler cap. Remove the filler cap with its integral dipstick. Ensure that the filter is serviceable by withdrawing for examination. Replace the filter and add clean oil until the dipstick records the oil level at the MAX. mark. The oil level must never be allowed to fall below the MIN. mark whilst filling or bleeding the system. Replace the filler cap and turn the depressurisation cock handle down.

WARNING...

Failure to get the depressurisation cock to the correct position after filling the system may cause venting at, and probable damage to the pumps when No.3 and 4 power units are started up. If the oil has fallen to or below the MIN. mark, the starboard engines must not be started until the reservoir has been topped up and the hydraulic pumps re-primed (para.44, operation 13).

PRE-FILLING THE JACKS

43. When the jacks are removed for any reason, a considerable saving of work may be effected by separately filling the jacks before re-fitting. To do this, a hydraulic component test rig consisting of a hand pump, reservoir and a suitable control valve is used. Extension and retraction of each jack should be repeated several times to expel all air and the final filling should be arranged to leave the jacks in the extended position which will facilitate fitting them to the aircraft. The flap jack is extended in the flaps down position.

FILLING THE SYSTEM

44. The procedure for filling the complete system is as follows:-

(1) Jack and trestle the aircraft as described in Sect.2, Chap.4. There are three different sets of equipment available for this purpose and the availability of equipment will determine limitations on the performance of the operations detailed in this paragraph and paragraph 46, 47 and 48.

(a) Using 25-ton jacks, a No.17 U.J. trestle at former 41 and a steadying U.J. trestle No.9A under the nose at former E, all circuits can be filled, bled or operation tested, provided the main wheels are jacked 5 in. clear of the ground and the lifting screws on the No.17 U.J. trestle extended 12 in.

WARNING...

A nose-steadying trestle must always be used when a No.17 U.J. trestle is used at former 41.

(b) Using 25-ton jacks and a No.15 U.J. trestle at former 41 (Rigging Position) the scanner must not be lowered beyond the 2nd Search position.

WARNING...

The ATTACK position on the scanner control switch must never be selected and the manually operated push-buttons on the scanner control valve should never be handled when the tail is supported on any other than a No.17 U.J. trestle as in (a) above.

(c) Using 25-ton jacks and an 8-ton pillar jack at the tail, the scanner must be kept up and must not be operated. If alighting gear operation is to be tested (para.48) the tail should be securely picketed

to prevent any possibility of the aircraft swaying off the jack. Four picket ropes are necessary to prevent fore-and-aft or transverse sway.

(d) If no jacking and trestling equipment is available, the alighting gear must be locked by use of the jury struts for the main and tail wheel units. Then the bomb doors, flaps, and, after disconnection, the alighting gear jacks may be operated.

(2) Disconnect the main-wheel and tail-wheel jacks at the radius rods and anchor them clear of the structure to allow safe extension and retraction and practical access to the pipe connections and bleed screws. Do not disturb the adjustment of the piston rod eye-ends as this would affect the setting of the up and down locks and might lead to subsequent accident or damage.

(3) Pour hydraulic oil into the reservoir until it reaches the correct level as indicated by use of the dipstick. As oil is pumped into the system, maintain the oil level in the reservoir by frequent addition of oil. Ensure that the reservoir is pressurised after each filling, that is, the cock handle at the top of the reservoir must be turned down.

(4) Ensure that a fully charged ground starter trolley is plugged into the aircraft ground starter socket (Sect.5, Chap.1).

(5) Select undercarriage UP. On the ground this will entail the use of considerable force on the button unless a short circuiting test switch is used to override the interlock device (Sect.5, Chap.1).

RESTRICTED

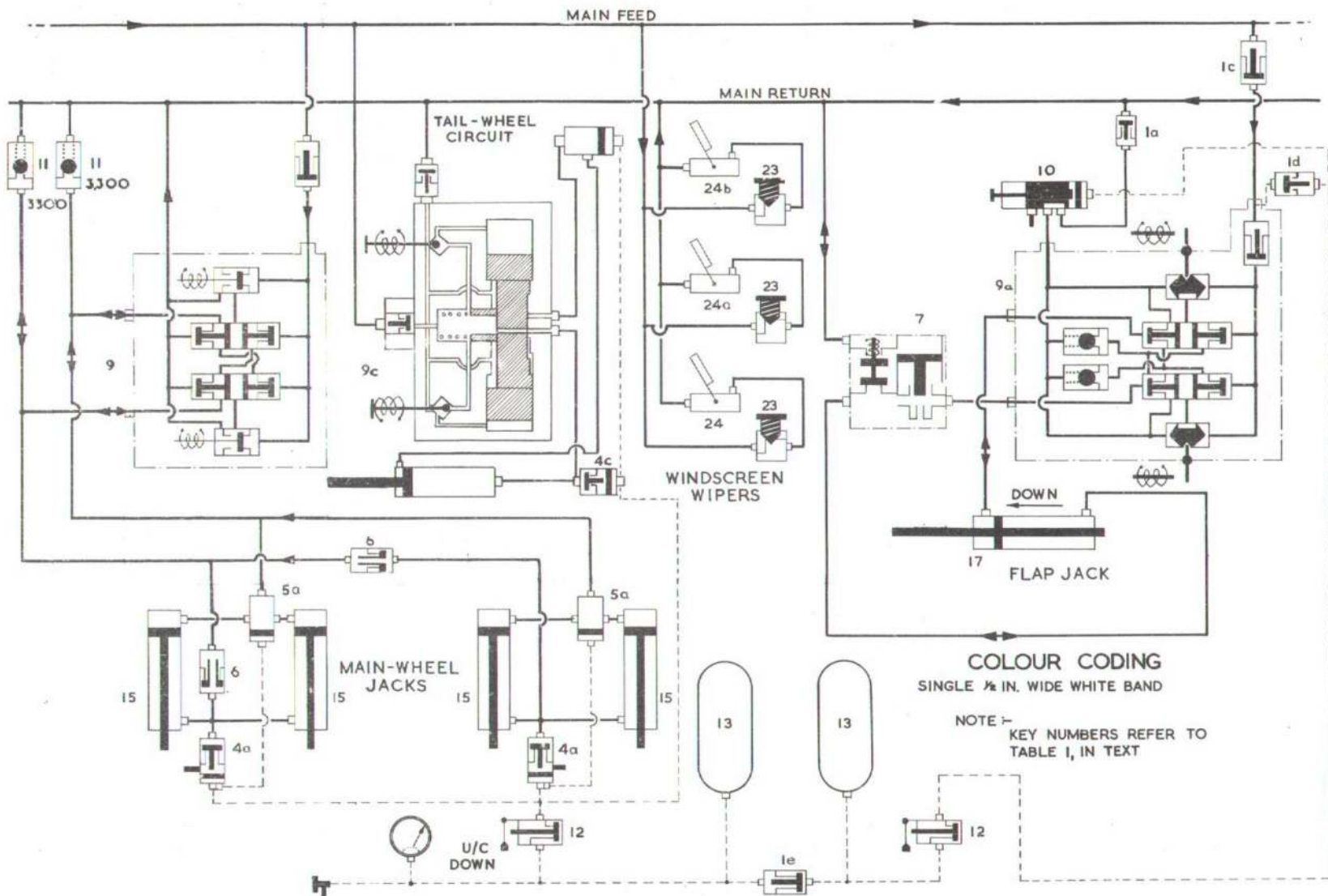

Fig.12. Hydraulic diagram (2) lighting gear, windscreen wipers and flaps

RESTRICTED

Undercarriage control). Such a switch must be temporarily fitted and used in preference to applying the necessary pressure to operate the button without it.

- (6) Operate the hand pump. When all undercarriage jacks are fully retracted, press the DOWN button and pump until they are fully extended.

NOTE...

The hand pump must be operated vigorously to ensure that the control unit piston valves are kept open.

- (7) Repeat this process several times for the flaps and bomb doors. In the latter case disconnect the jacks. Use the full range of the flap and bomb door jack movements.

NOTE...

The following procedure necessary for properly filling the scanner circuit cannot be undertaken unless the necessary tail trestling equipment is available (refer to operation (1)).

- (8) To fill the scanner circuit, select UP and open the up bleed screw on the port jack and pump until a clear stream of oil emerges. Close the screw and open the down bleed screw on the jack and pump until the jacks are fully retracted, if not already so, and continue pumping against the increased resistance felt (due to oil being forced through the pressure-relief valve connected across the port jack) until oil emerges from the down bleed screw. Close the down bleed screw and open the up bleed screw on the starboard jack. Pump until a clear stream of fluid emerges then close the bleed screw

and pump up to maximum resistance (due to oil being forced through the pressure-relief valve connected across the starboard jack). Then select DOWN, open the down bleed screw on the starboard jack and pump until a clear stream of oil emerges, close the bleed screw and continue pumping until the scanner is fully extended and the pump relief valve blows off. Carefully bleed at both down bleed screws until all air is released and clear streams of oil emerge. Repeat this cycle of operations at least five times to expel all air from the closed portion of the system between the jacks.

- (9) Bleed as in para.46, operations (2) to (5).
- (10) Connect all five alighting gear jack piston-rods to the retraction struts.
- (11) Carry out operation tests (para.48), refer also to operation (1).
- (12) Lower the aircraft from the jacks.
- (13) To prime the pumps, ensure that the handle of the cock at the top of the reservoir (No.4 power plant nacelle) is turned down. With the associated engine running slowly and driving the pump, unscrew the plug from the pressure gauge connection in the main casing of the pump until oil, free from air, is discharged. When this condition is obtained tighten the plug. During this operation the oil level in the reservoir must not fall below the minimum mark on the dipstick.
- (14) Run the engines to prime the power circuit and operate the flaps and bomb door circuits several times. If hydraulic ground service trolleys are available, jack the aircraft,

after the power circuit has been primed, and test in accordance with para.48 and Table 3, including the WARNING at the bottom of the table. Then lower the aircraft from the jacks.

- (15) Finally check the level of the fluid in the reservoir and top up as necessary.

BLEEDING

45. The complete hydraulic system must be bled after filling and the affected circuit must be bled after fitting any component and after an emergency air operation.

Normal bleeding

46.

- (1) Jack the aircraft as described in paragraph 44.
- (2) With the alighting gear fully down and the jacks disconnected from the radius rods, slacken the up line connection or bleed screw at each jack in turn, select UP and operate the hand pump until a bubble-free flow of oil emerges. Tighten each connection before proceeding to the next union. When this operation is complete, pump until all the alighting gear jacks are fully retracted. Top up the reservoir.
- (3) Repeat this operation for the flaps (do not disconnect the jack piston rod) and for the bomb doors with the jack piston rod ends disconnected from the bomb doors. When the up connections or bleed screws of the jacks are bled, tighten them and pump until the jacks are fully retracted and top up the reservoir.
- (4) Repeat operations (2) and (3) after

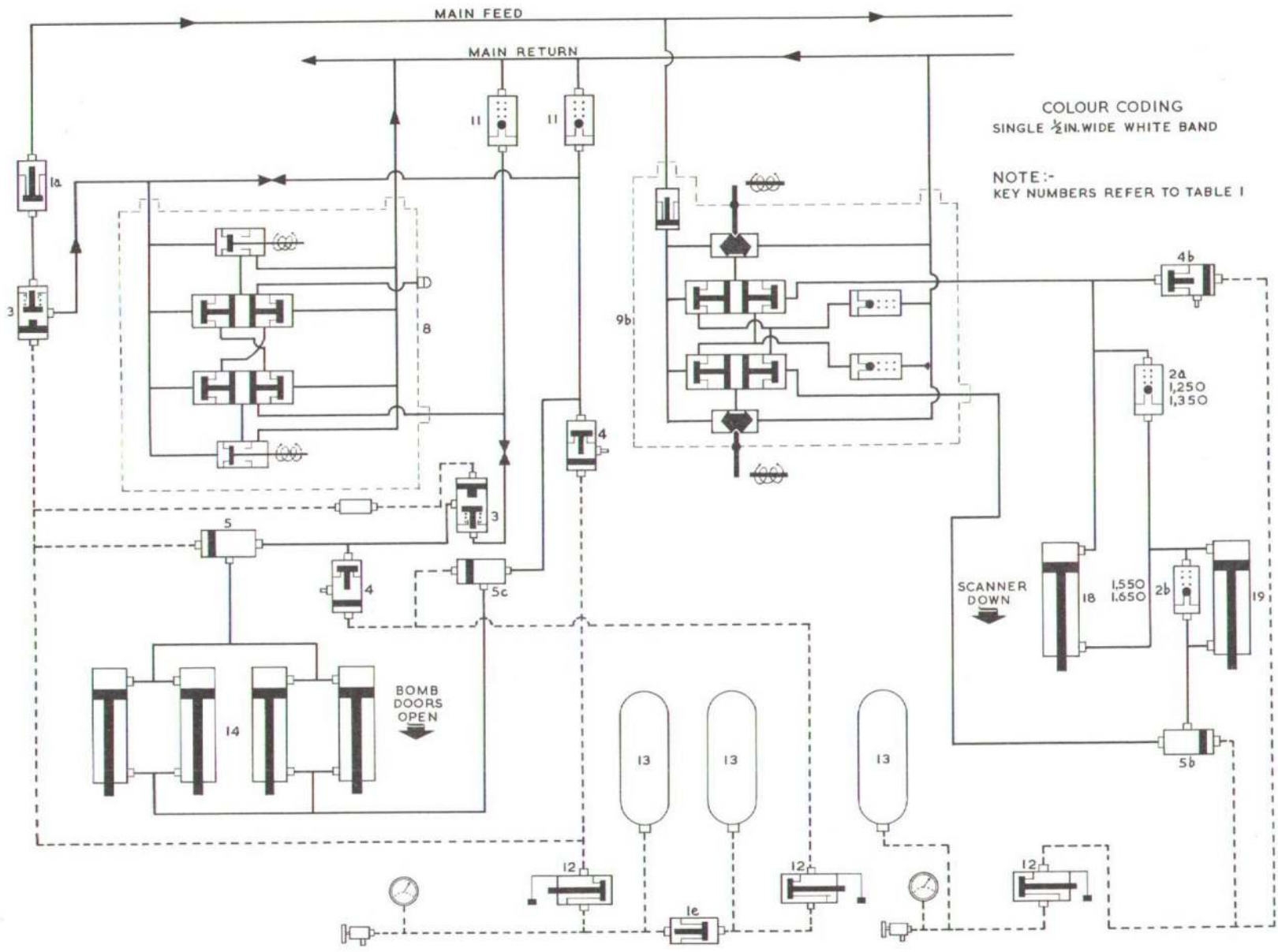

Fig.13. Hydraulic diagram (3) bomb doors and scanner
 (Amendment to piping)
RESTRICTED

selecting DOWN. Bleed all down unions and extend all jacks, topping up the reservoir after bleeding each service. In addition whilst bleeding the bomb door circuit bleed from the release plug (fig.7) connected to the four-way union at the aft end of the bomb compartment.

- (5) To bleed the scanner circuit, select UP, open the 'up' bleed screw and pump until a clear stream emerges, then close the bleed screw. Pump again until the scanner is fully retracted and build up the pressure by continued pumping to force oil into the pipe between the jacks and bleed at both the 'down' bleed screw on the port jack and the 'up' bleed screw on the starboard jack. Select DOWN, open the 'down' bleed screw on the starboard jack and pump until a clear stream of oil emerges, then close the screw. Pump the scanner down, build up maximum pressure and again bleed at both port 'down' and starboard 'up' bleed screws. Repeat this cycle of operations several times to remove all air trapped between the jacks.
- (6) Reconnect all five alighting gear jack piston rods to the radius rods.
- (7) Correct the oil level in the reservoir and carry out operational tests (para.48).
- (8) Prime and bleed the pumps (para. 44, operation 13) and top up the reservoir.
- (9) Finally, carry out the procedure detailed in para.44, operation (14) and (15).

Bleeding after use of emergency air

47. Whenever a service has been operated by use of emergency air, it must be bled in line with the following procedure:-

- (1) Jack the aircraft as in para.44 (1) using a No.15 U.J. trestle at former 41 unless the scanner circuit is to be bled, when a No.17 U.J. trestle must be used. If a No.15 U.J. trestle is not available, use the tail jacking equipment (items 10, 11 and 19, Table 1 of Sect.2, Chap.4) and securely picket the tail to prevent any sway if subsequent operation testing of the alighting gear is necessary.
- (2) Establish the nature and cause of the hydraulic failure which necessitated use of emergency air and rectify it.
- (3) Ensure that the levers of all emergency air release valves are returned to and locked at their OFF position.
- (4) Slacken the pipe connections at each jack, or the bleed screws, in turn, about one thread, to allow all trapped air to escape slowly. To release air trapped in the bomb door system, slacken, but do not remove, the release plug on the starboard side of the fuselage, aft of former 22 and below the longeron extension.

NOTE . . .

Keep a check on the level of oil in the reservoir throughout the operations in this paragraph and top up as necessary.

- (5) Bleed the system as described in para.46, operations (2) to (5). Repeat all selections several times

to ensure expulsion of all trapped air.

- (6) If, during this operation, oil escapes from the vents of any of the emergency air-operated jettison valves, tap each affected valve sharply with a hide-faced mallet to return it to its normal position.
- (7) Finally, carry out the procedure detailed in para.46, operations (6) to (9).
- (8) When the air from all jacks has been released, reset the air-operated change-over jettison valve. This is located near the flaps selector valve under the flap jack cover in the fuselage. Refer to fig.6, item 10, noting that the resetting point is at the aft end of this valve, and that a 1/4 in. B.S.F. spanner must be used. To reset turn anti-clockwise.

WARNING . . .

The resetting point must not be set at any other time excepting as given in this sequence of operations. The WARNING at the foot of para.31 refers.

OPERATION TESTING

48. When the system has been filled or bled it is necessary to test each circuit. Jack the aircraft as described in para.44

- (1) A hydraulic servicing trolley Mk.2A (Ref. No. 4F/1796), equipped with the same type of pump as those fitted to the aircraft (Leading Particulars) is required (refer to A.P.2036B). To connect the trolley to the aircraft, disconnect the self-sealing couplings from both aircraft pump lines in the starboard engine nacelles and connect the trolley to the set of couplings in one of the nacelles to feed the main circuit. Check that the trolley reservoir is filled

TABLE 3

Operating times for hydraulic services

Service	Down or open	Up or closed
<i>In the air</i>		
Main wheels	18 seconds (2,600 r.p.m.)	12.5 seconds (2,750 r.p.m.)
Flaps (2,600 r.p.m.)	3.5 seconds to TAKE-OFF 6 seconds TAKE-OFF to DOWN	8 seconds to TAKE-OFF 12.5 seconds TAKE-OFF to UP
Bomb doors (2,400 r.p.m.)	9 seconds	9 seconds
Scanner	17 ± 2 seconds	28 ± 3 seconds

NOTE . . .

The above times are subject to a variation of 10%. When normal automatic retraction of the scanner occurs after selection of undercarriage DOWN, the time of operation of both services together is 40 - 45 seconds.

◀ On the ground, using two hydraulic trolleys, Mk. 2A, Ref. No. 4F/1796, at 2,950 r.p.m. ▶

Main wheels	16 ± 2 seconds	15 ± 2 seconds
Tail wheel	4 ± 1 second	4 ± 1 second
Flaps	8 ± 2 seconds to DOWN	15 ± 2 seconds to UP (5 ± 1 second - DOWN to 20 deg. 10 ± 1 second - 20 deg. to UP).
Bomb doors	6 ± 1 second	6 ± 1 second
Scanner	8 ± 1 second 1st SEARCH position 5 ± ½ second 1st SEARCH to 2nd SEARCH 10 ± 1 second 2nd SEARCH to ATTACK 19 ± 2 seconds UP to ATTACK	16 ± 1 second to 2nd SEARCH position 6 ± 1 second 2nd SEARCH to 1st SEARCH 10 ± 1 second 1st SEARCH to UP 27 ± 3 seconds ATTACK to UP

On the ground, using one hydraulic servicing trolley as above.

Flaps	8 ± 2 seconds to DOWN	As for two trolleys (see above)
Bomb doors	8 ± 1 second	9 ± 1 second

WARNING . . .

Undercarriage retracting and lowering carried out with only one servicing trolley proceeds in a series of jerks which shake the aircraft considerably. The accompanying danger of failure of jacks and trestles makes it most inadvisable to attempt to do undercarriage functioning tests in these circumstances.

- 1 RELEASE AIR PRESSURE IN HYDRAULIC FLUID RESERVOIR.
- (2) REMOVE ALL BOLTS SECURING COVERS TO FLOOR AND JACK MOUNTING PLATFORM.
- (3) LIFT PORT, CENTRE AND STARBOARD COVERS AWAY, PORT COVER WITH TRIM CONTROL COVER ATTACHED.
- (4) DISCONNECT LINKS FOR FLAP-OPERATING TUBES (SEE DETAIL A) USING C-SPANNER (REFER TO SECT.2, CHAP.4, TABLE 2).
- (5) RELEASE PIPE UNIONS AT EACH END OF JACK.
- (6) REMOVE NUTS AND WASHERS SECURING JACK TO PLATFORM.
- 7 LIFT JACK AWAY FROM STUDS.

NOTE...
OPERATIONS NOT IN BRACKETS ARE NOT ILLUSTRATED.

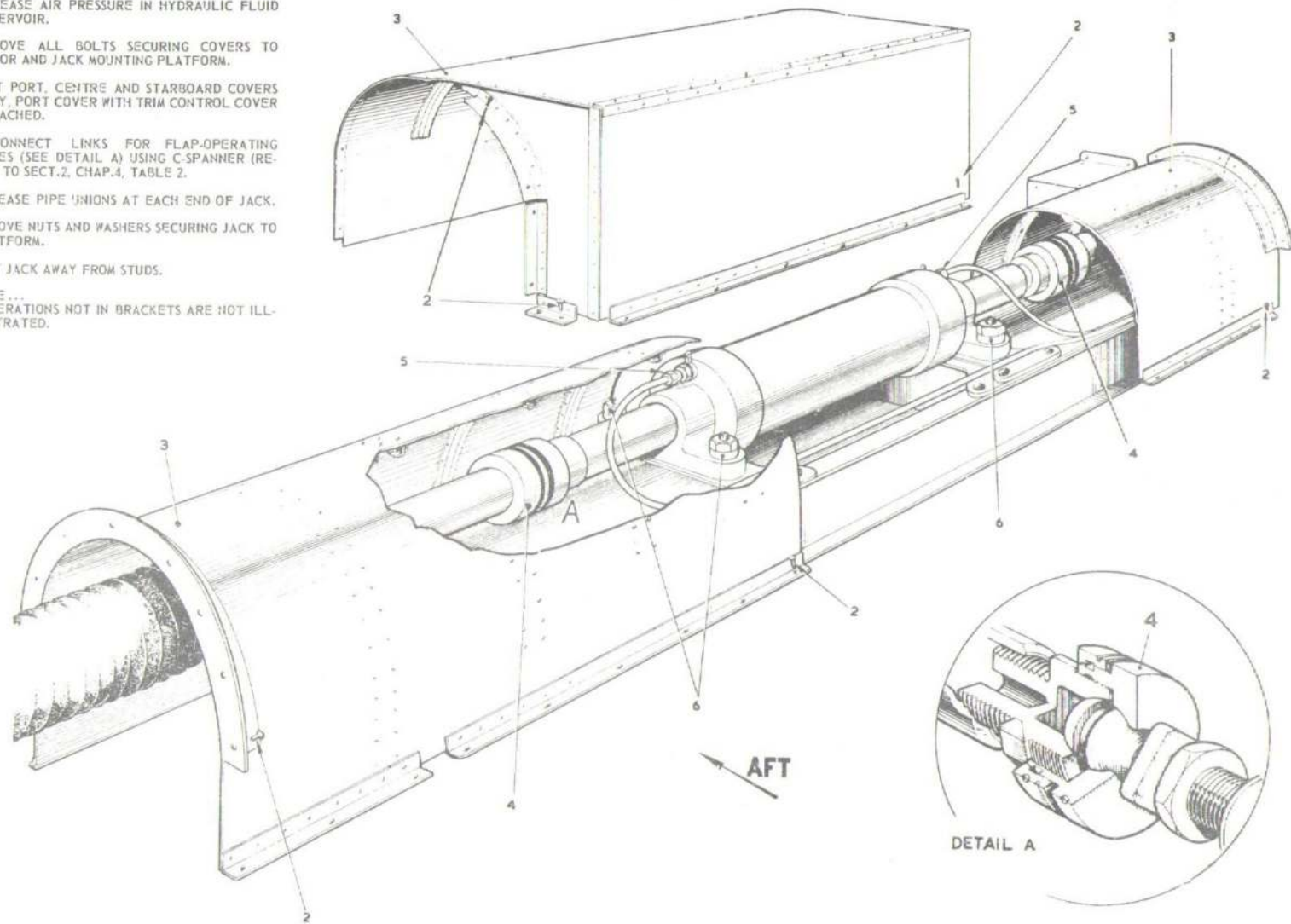

Fig. 14. Removal of flap jack.

RESTRICTED

with the correct oil (Leading Particulars). After starting up the trolley and ensuring that it is running at its correct speed (2,950 r.p.m.) the operation of the various circuits can be tested using the normal aircraft controls. Refer to Table 3 for the correct operating times of the various circuits. Check that the scanner retracts when the alighting gear is lowered.

NOTE . . .

Two trolleys are required if undercarriage functioning tests are to be carried out (Table 3). The second trolley is to be connected to the self-sealing couplings in the other starboard nacelle and set to run at 2,950 r.p.m.

ADJUSTMENT OF BOMB DOORS

49.

- (1) Drain the bomb door circuit.
- (2) Disconnect the four jacks at their lower pins.
- (3) Fully close each jack by hand.
- (4) Close each door in turn and hold it flush with the fuselage to ascertain the adjustment required for each jack.
- (5) Slacken the lock-nut, screw the eyebolt in or out (to shorten or lengthen the jack as required) and tighten the lock-nut.
- (6) Lower the doors, then extend the jacks and connect them to the doors.

FLAP JACK (fig. 14)

52. The method of removal of this component which is located in the rear

(7) To check the adjustment, close each door in turn, then close both together. They should meet evenly along the whole length of the joint. Sag should not exceed 3/8 in.

(8) Sagging in excess of 3/8 in. may be remedied by setting the door which sags to close slightly inside the skin line and setting the other door to close slightly outside the skin line.

(9) Finally fill the bomb door circuit as described in para.44.

WINDSCREEN WIPER SYSTEM BLEEDING

(front gunner)

50. The procedure for priming and bleeding the front gunner's windscreen wiper system is as follows:-

- (1) Remove the wiper blade and operating arm assembly.
- (2) Fill the reservoir of the pump unit with oil OM-15.
- (3) Operate the system at slow speed and continue filling the reservoir until the fluid level remains constant at approximately 1/2 in. below the filler orifice. Continue operation of system until all air is expelled. If difficulty is experienced in expelling the air, it is permissible to slacken off the 1/8 in. B.S.P. unions on the wiper head.

REMOVAL AND ASSEMBLY

centre section, level with the turret pedestal, is shown in the illustration. Refer

(4) When all the air has been expelled tighten the unions, switch off the system and wire-lock the unions as necessary. Top up the reservoir to the level stated in operation (3) and replace the filler cap.

(5) Fit the wiper blade and operating arm assembly in accordance with the instructions given in para.51 of this chapter.

WARNING . . .

Wipers must not be operated on a dry windscreen.

WINDSCREEN WIPER SETTING

(front gunner)

51. The procedure for setting the actuating arm and blade is as follows:-

- (1) Slacken the 1/8 in. B.S.P. unions on the wiper head to relieve hydraulic pressure and prevent hydraulic locking.
- (2) Turn the serrated drive of the wiper head clockwise to the limit of travel. Tighten and wire-lock the unions.
- (3) Fit the arm, complete with parallel motion assembly and wiper blade to the serrated drive of the wiper head so that the blade pivot is just touching the port stop.
- (4) Adjust and connect the parallel motion rod to its pivot just below the windscreen.
- (5) Operate the wiper and check for full and free movement.

to Sect.3, Chapter 4, for further details of the flap system.

RESTRICTED

SCANNER JACKS

Removal

53. This operation is effected as follows:-

- (1) Jack the aircraft as for scanner testing.
- (2) Refer to the warning in para.23 (3) then fully retract the scanner, if necessary, by using a servicing trolley or the hand pump.
- (3) Remove the floor panels between the jacks and between formers 23 and 28.
- (4) Remove the transverse bracing member by first releasing two bolts securing the starboard end and three bolts securing the port end, and lifting this end clear before withdrawing the starboard end.
- (5) Disconnect all cables from the A.S.V. equipment in the cupola (Sect.6, Chapter 2, Fig.2).
- (6) Release the cable fairlead on the bridge member over the cupola and coil all cables in the vicinity of the scanner break panel (Sect.6, Chapter 2, Fig.2).
- (7) Remove the T.R.3523B/W.W., the transverse support rail bracket.
- (8) Lower the scanner to the ATTACK position by using the hand pump or a hydraulic servicing trolley (para.48).
- (9) Remove the radome by releasing the upper row of screws, which are at approximately 6 in. centres, securing it to the metal part of the cupola
- (10) Remove the scanning unit (A.P.2544, Vol.1).

- (11) Disconnect the 'down' and 'up' lines from the jack or jacks to be removed and blank them off.

NOTE . . .

The remainder of this procedure refers to the starboard jack only.

- (12) Remove the top and bottom panels from the floor beam immediately aft of the jack.
- (13) Remove the intercostal which is bolted between the two main members of the floor beam immediately aft of the jack.
- (14) Remove the bungee cord guards and clips from the outer housing of the jack.
- (15) Release the bungee cords from the top anchorage.
- (16) Support the metal part of the cupola and remove the two vertical bolts securing the jack to the cupola structure. Retain the shimming washers fitted.
- (17) Fully retract the jack manually, holding a suitable receptacle under the 'down' connection to catch the expelled oil.
- (18) Blank off the jack connections.
- (19) Remove the two bolts securing the jack housing to the jack beam.
- (20) Support the jack assembly and remove the upper jack attachment bolt, at the fuselage roof.
- (21) Lower the jack slightly and then move it aft and upward to withdraw it from the jack beam.

To remove the port jack, proceed as for

the starboard jack with the following additional operations:-

- (11a) Disconnect the cables for the micro switches at the plugs on the outboard side of the associated jack beam, aft of the jack. Then remove the fairlead from the floor skin alongside the jack and pull the cables clear, through the floor skin.

- (15a) Remove the bungee cord guard complete with micro switches, mounting channel and wiring.

WARNING . . .

Do not disturb the settings of the micro switches on the channel.

Dismantling of the jack assembly and all servicing operations and testing are described in A.P.1803D, Vol.1, Book 4, Chapter 57.

Assembly

54. Refitting a complete jack assembly is effected, with the aircraft jacked as for removal, as follows:-

- (1) Pass the jack through the floor beam and attach its upper end to the fuselage roof fitting.
- (2) Attach the jack to the jack beam.
- (3) Connect the 'up' and 'down' pipes to the jack.
- (4) Fully extend the jack.
- (5) Bleed the jack and top up the hydraulic reservoir (para.42).
- (6) Attach the lower end of the jack to the upper metal portion of the cupola, using the shimming previously retained.

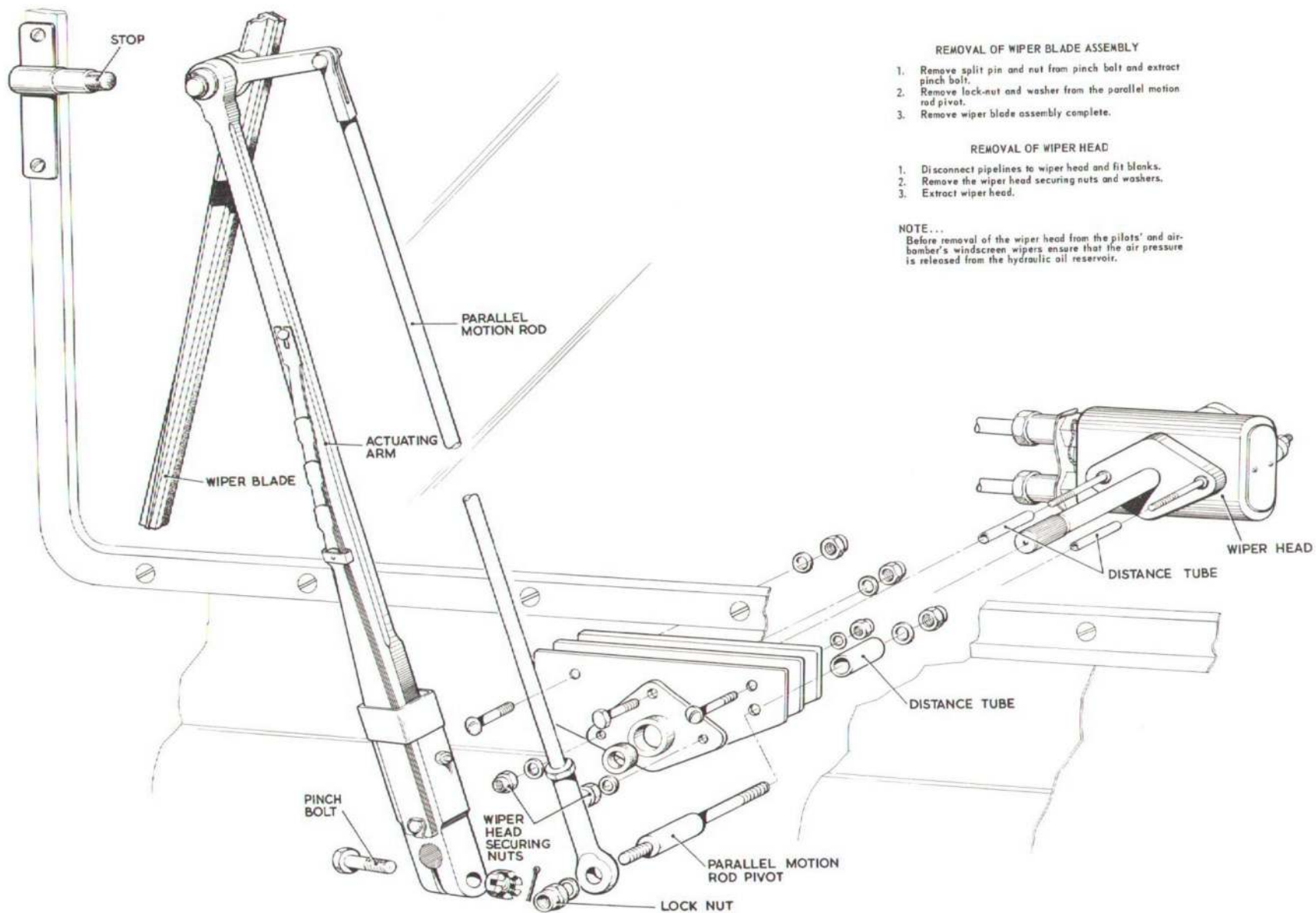

Fig. 15. Removal of windscreen wiper.

RESTRICTED



This file was downloaded
from the RTFM Library.

Link: www.scottbouch.com/rtfm

Please see site for usage terms,
and more aircraft documents.

