

Fig. 1. Aerofoil de-icing system

RESTRICTED

the supply when the filter is to be cleaned. The cock is normally wired in the ON position.

Filter

4. The filter is mounted on the rear face of the bulkhead below the rear spar at the aft end of the main wheel compartment, and is accessible by the removal of a large panel in the underside of the rear nacelle fairing.

Pump

5. The pump is mounted alongside the filter. A vent pipe from the pump is led, adjacent to the tank, above the fluid level to ensure that the pump chamber is completely filled with fluid as this is the sole lubricant for the pump. For this reason the pump must never be run unless there is fluid in the tank. Each delivery unit of the pump is calibrated to give the required flow for each section of the porous metal insert system as follows:-

Marginal outlet No.	Surface fed	Delivery c.c./min.
1	Port outer main plane	219
2	Starboard outer main plane	219
3	Port intermediate main plane	168
4	Starboard intermediate main plane	168
5	Port centre plane	128
6	Starboard centre plane	128
7	Fins	234
8	Tail plane	250

Tolerance on these figures is ± 10 c.c./min. The pumps are calibrated on a test bench and the settings must not be altered on the aircraft.

Controls

6. A control panel and unit Type B is

used, the panel being mounted on the flight engineer's main panel. For a description and operation of the control system refer to Book 2, Sect.5, Chap.1 of this Volume and A.P.1464D, Vol.1. When MANUAL operation is selected, the pump on/off ratio is one to four. The duration of the system is five hours on MANUAL and one hour on emergency when the flow is continuous.

PROPELLER DE-ICING SYSTEM (fig.2)

7. The system employs components similar to those used in the aerofoil de-icing system, except that the porous metal inserts are replaced by an arrangement of slinger rings on the propellers (refer to A.P.1538K, Vol.1).

De-icing fluid tank

8. This is installed in the starboard wheel compartment in a manner similar to the aerofoil de-icing tank in the port wheel compartment but, has a capacity of 33 gallons.

Pump and filter

9. Both are mounted in the starboard nacelle in relatively similar positions to those of the aerofoil de-icing system in the port nacelle and the information contained in para.4 and 5 applies to these components. Each unit of the pump is calibrated as follows:-

Pump outlet No.	Propeller fed	Delivery c.c./min.
1)	No.2	130
2)		130
3)	No.1	130
4)		130
5)	No.4	130
6)		130
7)	No.3	130
8)		130

Tolerance on these figures is ± 10 c.c./min. The pump is calibrated on a test bench and must not be altered on the aircraft.

Controls

10. A means of control similar to that for the aerofoil system is used. The on/off ratio, when on MANUAL operation, is one to one and a half and the duration is three hours. On emergency the duration is two hours.

Distribution of fluid forward of firewalls

11. Piping is run from the de-icing connections on each firewall to the hub of the rear half of the corresponding propeller where the fluid is fed into a slinger ring. This distributes the fluid to the rear blades and to a front slinger ring which distributes fluid to the front blades. For further information refer to A.P.1538K, Vol.1.

VISION DE-ICING SYSTEM

12. In this system provision is made for spraying de-icing fluid on to the pilots', forward gunner's and air bomber's windscreens.

De-icing fluid tank (pre Mod.771)

13. The tank is located under the floor between formers E and F immediately forward of the bomb compartment, as shown in fig.3 and is pressurised to 7 p.s.i. from the pneumatic system. The filler cap, in the centre of a circular depression at the top of the tank has an integral dipstick marked at the $\frac{1}{2}$ FULL position, the capacity of the tank being 7 gallons. A drain pipe is led from the circular depression, which serves as a drip tray, through the underside of the nose to atmosphere.

De-icing fluid (post Mod.771)

14. On aircraft with Mod.771 embodied the tank, mounted between formers E and

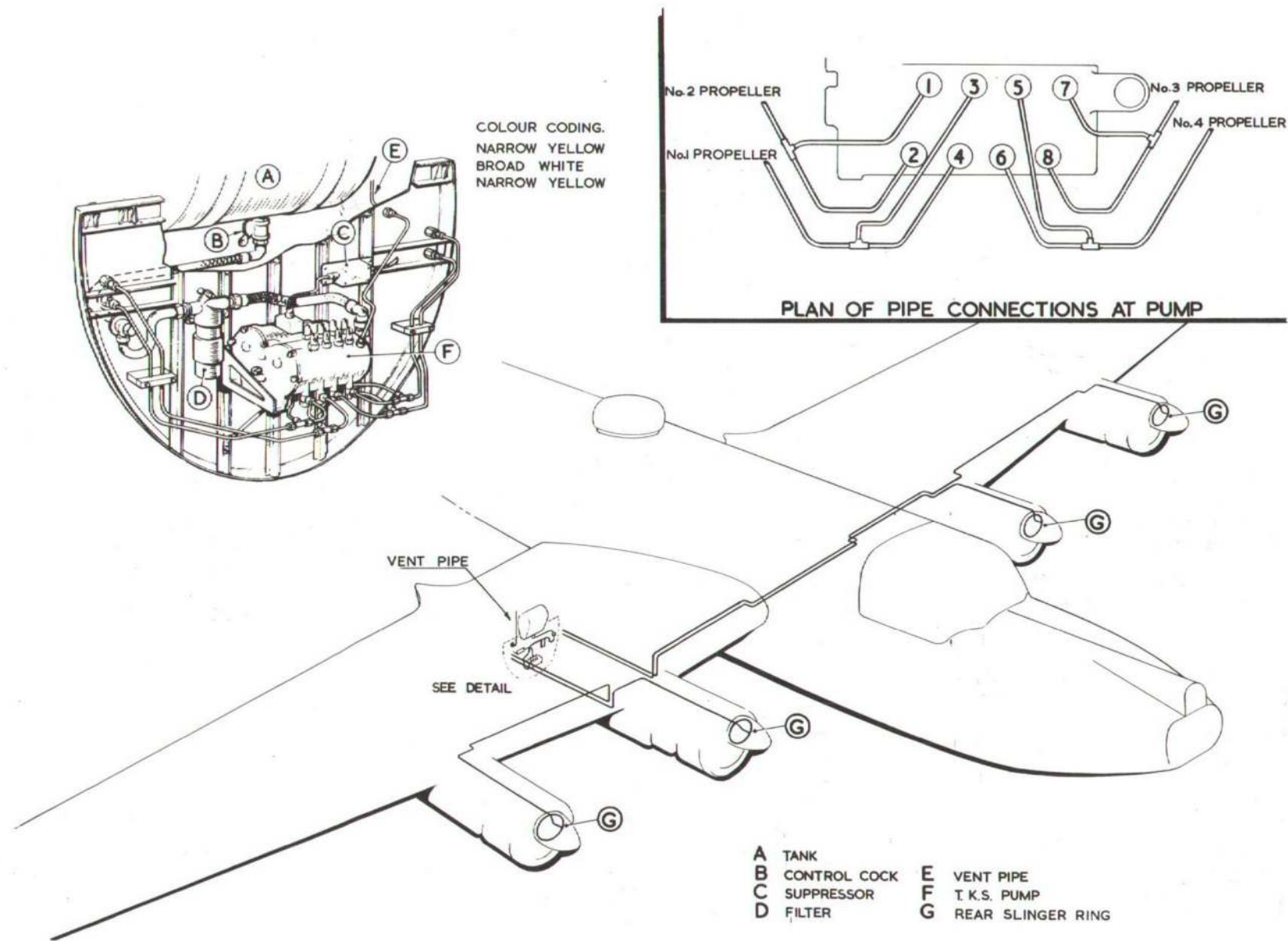
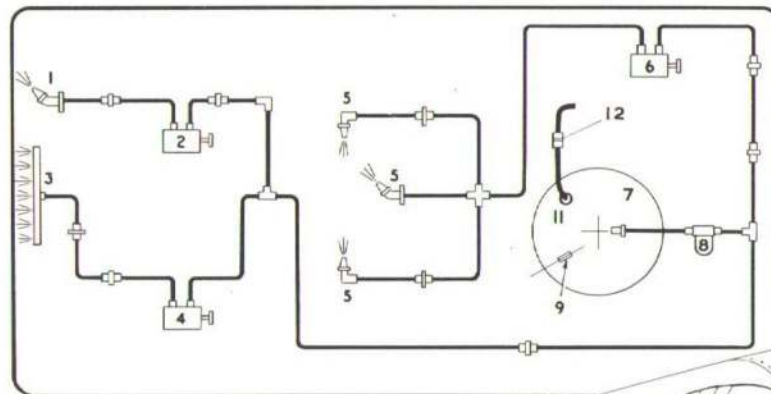

Fig. 2. Propeller de-icing system

RESTRICTED



IDENTIFICATION COLOUR BANDING
 1/2 IN. WIDE WHITE BAND WITH
 1/4 IN. WIDE BROWN BAND EACH
 SIDE

KEY

- 1 GUNNER'S WINDOW SPRAY
- 2 GUNNER'S CONTROL VALVE
- 3 AIR BOMBER'S WINDOW SPRAY
- 4 AIR BOMBER'S CONTROL VALVE
- 5 PILOT'S WINDSCREEN SPRAYS
- 6 PILOT'S CONTROL VALVE
- 7 DE-ICING FLUID TANK
- 8 FILTER
- 9 FILLER SPLASH DRAIN
- 10 DETACHABLE ACCESS PANEL
- 11 PNEUMATIC PRESSURISATION CONNECTION
- 12 MODIFIED AVERY COUPLING

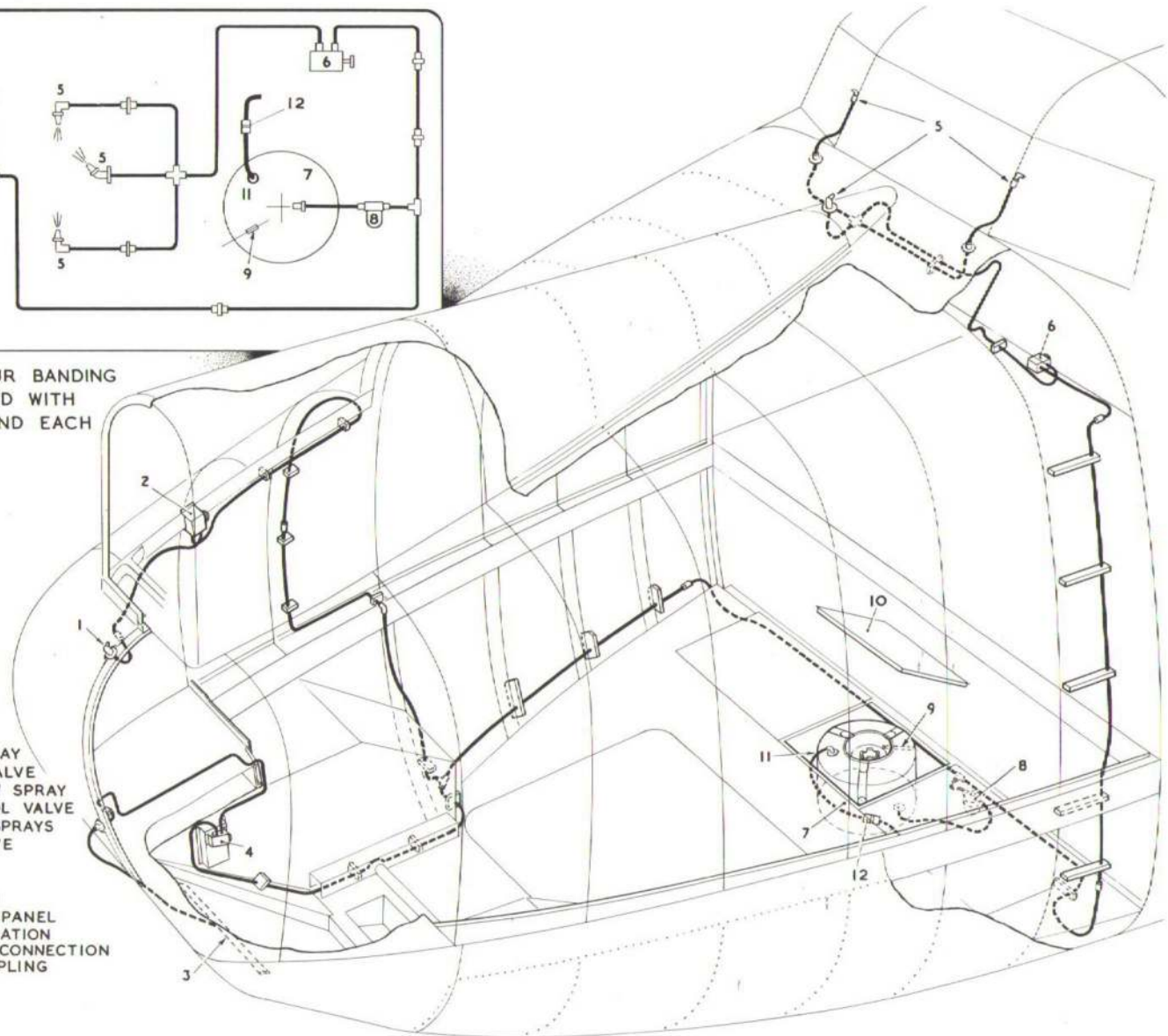
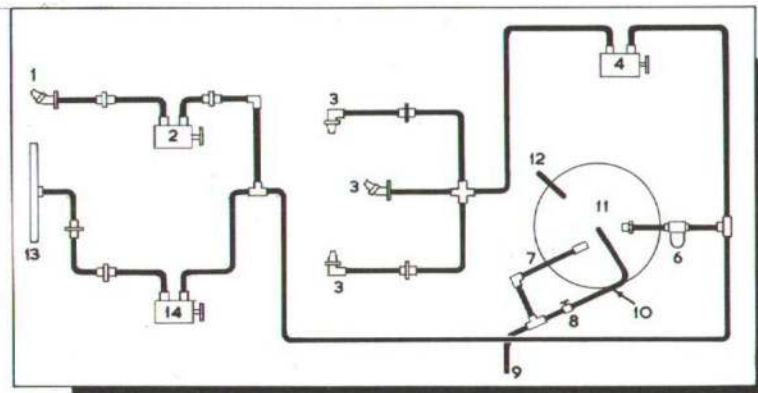

Fig. 3. Vision de-icing system (pre Mod. 771)

RESTRICTED



1. GUNNER'S WINDOW SPRAY
2. GUNNER'S CONTROL VALVE
3. PILOT'S WINDSCREEN SPRAYS
4. PILOT'S CONTROL VALVE
5. HINGED ACCESS PANEL
6. FILTER
7. FILLER SPLASH DRAIN
8. TANK DRAIN COCK
9. TANK DRAIN OUTLET
10. TANK DRAIN PIPE
11. DE-ICING FLUID TANK
12. TANK PRESSURISATION PIPE
13. AIR BOMBER'S WINDOW SPRAY
14. AIR BOMBER'S CONTROL VALVE

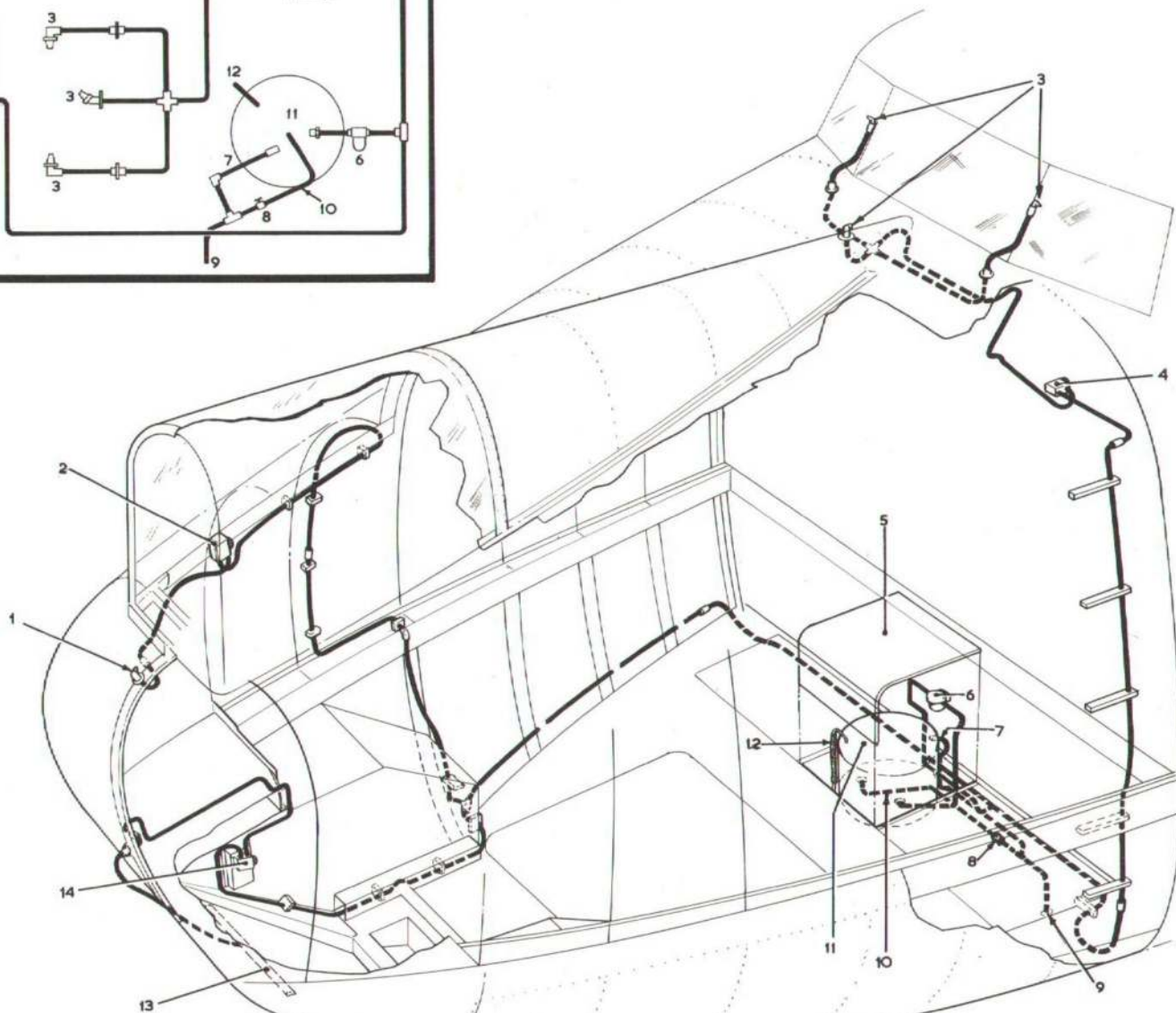

Fig.4. Vision de-icing system (post Mod. 771)

RESTRICTED

F, is positioned higher than in the pre Mod.771 state and covered by a hinged step. A tank drain incorporating a manually-operated on/off cock is connected to the bottom of the tank and terminates on the port undersurface of the nose section. From the circular depression at the top of the tank, which serves as a drip tray, a drain pipe is connected to the tank drain pipe down-

AEROFOIL AND PROPELLER SYSTEMS

17. Information regarding the servicing of all components of the propeller and aerofoil de-icing systems is contained in Air Publications as follows:-

Propeller system	A.P.1464C, Vol.1
Aerofoil system	A.P.1464D, Vol.1

VISION DE-ICING SYSTEM

18. General notes on similar systems are contained in A.P.1464D, Vol.1. No pumps are used in this system but the tank itself is pressurised to 7 p.s.i. from the pneumatic system (Chap.7), the flow of fluid being controlled by manually-operated screw valves (Part No.ACO.7472). The spray jets are provided with hexagonal bases to facilitate their removal for cleaning.

WINDSCREEN ANTI-MISTING SYSTEM

19. The air drying cartridges (Ref.

AEROFOIL AND PROPELLER SYSTEMS

21. The pump, filter and distribution piping connections are on the aft face of

stream from the on/off cock.

Piping and components

15. All piping of the system is indicated in the illustrations (fig.2 pre Mod.771 and fig.3 post Mod.771) which also contain diagrams of the system. All the components are referenced by numbers to which keys are provided.

SERVICING

No. 26FP/1578) are filled with an indicating type of silica-gel, either wholly or at the ends, with a middle filling of non-indicating silica-gel. The indicating material is blue when fresh and slowly changes to pink as it absorbs moisture. Cartridges should be renewed when the indicating material has become approximately two-thirds pink. The system must be subjected to a pressure test after being broken down to renew or refit silica-gel cartridges and the operation is carried out as follows:-

- (1) Remove the access panels to the breather bags and silica-gel cartridges in the nose.
- (2) Disconnect the three pipes from the self-sealing valves fitted to the windscreen panels and blank off each pipe immediately after disconnecting it.
- (3) Unscrew the cartridge connections

REMOVAL AND ASSEMBLY

each main-wheel rear bulkhead, the pumps and filters being secured by bolts. A manually-operated cock is provided at the outlet from each of the two tanks and this

WINDSCREEN ANTI-MISTING SYSTEM (fig.5)

16. Three dry air sandwich panels are fitted to the pilots' windscreen, the centre panel being strengthened by the addition of a layer of vinyl sheet. At one of the upper corners of each panel is a self-sealing valve to which the anti-misting system is connected. The arrangement of this system is shown in the illustration.

and by-pass the cartridges with temporary piping.

- (4) Connect a suitable pump to the starboard windscreen pipe and an A.S.I. system test manometer to the port windscreen pipe, leaving the centre pipe blanked off. Apply a pressure of 5 p.s.i. and test the system for leakage. The pressure to be applied for 20 min. without loss.
 - (5) The silica-gel cartridges are to be tested separately to a pressure of 2 p.s.i. the pressure to be maintained for 20 min. without loss.
 - (6) Disconnect the test rig and remake the three connections to the windcreens, tightening them carefully to ensure that they are leakproof.
20. The fabric tubes containing desiccant are built-in units and no servicing is necessary.

must be turned off when the pump or filter is removed. To remove any of these items disconnect all relevant piping and remove the bolts securing them to the bulkhead.

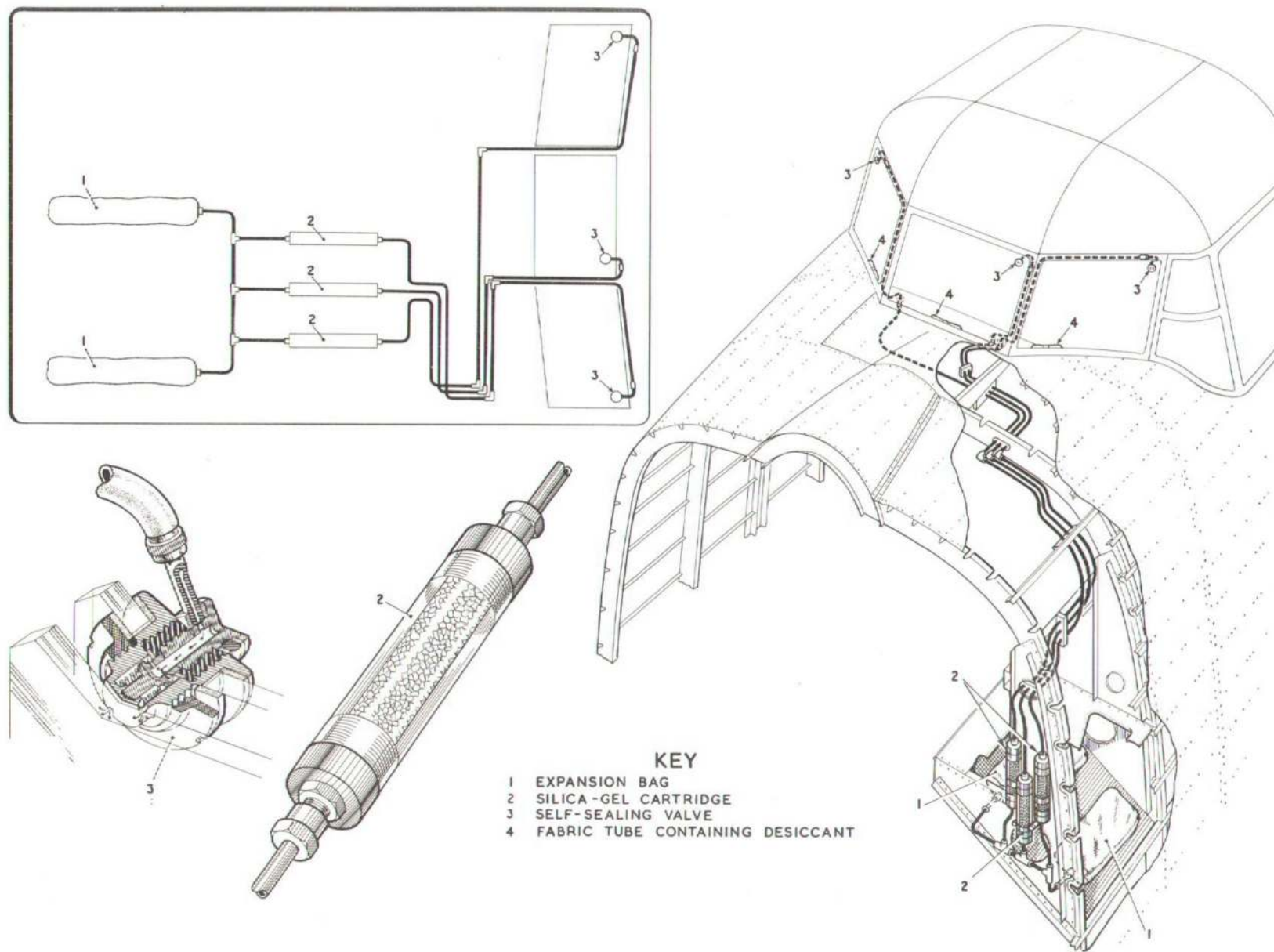

Fig. 5. Pilots windscreen anti-misting system

RESTRICTED

When these components have been fitted and all pipes connected turn the manually-operated cock at the associated tank outlet to the on position.

VISION DE-ICING SYSTEM

22. No specific instructions other than for the removal of the tank are necessary. The tank is removed as follows:-

- (1) Disconnect the modified self-sealing coupling in the pressurisation air line.
- (2) Remove the tank filler cap and mark the tank to facilitate orientation when installing it.
- (3) Remove the access panel on the underside of the nose immediately forward of former E.
- (4) Remove the tank drain plug and drain the tank into a vessel capable of holding 7 gallons.

- (5) Disconnect the de-icing fluid pipe from the bottom of the tank and the pressurisation and filler drain pipes from the top of the tank.
- (6) Release the wire locking from the turnbuckles of the retaining strap assembly.
- (7) Remove the top part of the strap assembly and lift the tank clear.

◀ De-icing tank (post Mod.771)

23. To remove the tank proceed as follows:-

- (1) Lift the hinged step to gain access to the tank.
- (2) Disconnect the modified self-sealing coupling in the pressurisation air line.
- (3) Remove the tank filler cap.
- (4) Position a vessel, capable of

holding 7 gallons, under the tank drain outlet, operate the drain on/off cock to drain the tank.

- (5) Disconnect the de-icing fluid delivery pipe and the drain pipe from the bottom of the tank and the pressurisation and filler drain pipes from the top of the tank.
- (6) Release the wire locking and undo the three retaining strap turnbuckles.
- (7) Remove the retaining ring, from around the filler neck, complete with the retaining strap halves and lift the tank clear of the mounting. ▶

WINDSCREEN ANTI-MISTING SYSTEM

24. No specific instructions are necessary other than for the windscreen panels. This procedure is detailed in Chapter 1 of this section.



Appendix 1 AEROFOIL DE-ICING SYSTEM (POST-MOD. 768)

LIST OF CONTENTS

DESCRIPTION AND OPERATION				SERVICING			
			Para.				Para.
<i>Introduction</i>	1	<i>General</i>	7
Main system	2	REMOVAL AND ASSEMBLY			
Transfer system	3	<i>General</i>	8
<i>Auxiliary de-icing fluid tank</i>	4	LIST OF ILLUSTRATIONS			
<i>Filter and pump</i>	5	<i>Aerofoil de-icing system (1)</i>	1A
<i>Controls</i>	6	<i>Aerofoil de-icing system (2)</i>	2A

DESCRIPTION AND OPERATION

Introduction

1. When Mod. 768 is introduced, the propeller de-icing system is deleted and a transfer system incorporated which utilizes the starboard de-icing tank and pump to provide additional de-icing fluid for the T.K.S. system serving the aerofoil surfaces.

MAIN SYSTEM

2. The main system is unaltered, with the exception of the connection of a transfer pipe

to the main tank, and is described in the text of Chapter 9.

TRANSFER SYSTEM

3. The main components of the system (*fig. 1A and 2A*) are a tank, pump and filter which were formerly part of the propeller de-icing system but which are now used to transfer de-icing fluid to the main tank.

Auxiliary de-icing fluid tank

4. The tank is unchanged and is described in the text of the chapter.

Filter and pump

5. The supply to the pump is as described in Chapter 9 but the eight outlets from the pump are now piped to a manifold which directs fluid into the main tank.

Controls

6. The control switch and magnetic indicator are located on the engineer's auxiliary panel (*fig. 2A*) adjacent to the contents gauge. A full description of the control circuit is given in Book 2 of this publication. With the pump in operation the transfer of fluid is

continuous and it is, therefore, important not to transfer fluid when the main system tank is full. A warning notice to this effect is stencilled on the engineer's auxiliary panel.

SERVICING

General

7. Information on the pumps and filters is contained in A.P.1464D, Vol. 1. The func-

tioning of the transfer system should be checked at routine servicing periods.

REMOVAL AND ASSEMBLY

General

8. Removal and assembly of components is as detailed in the chapter.

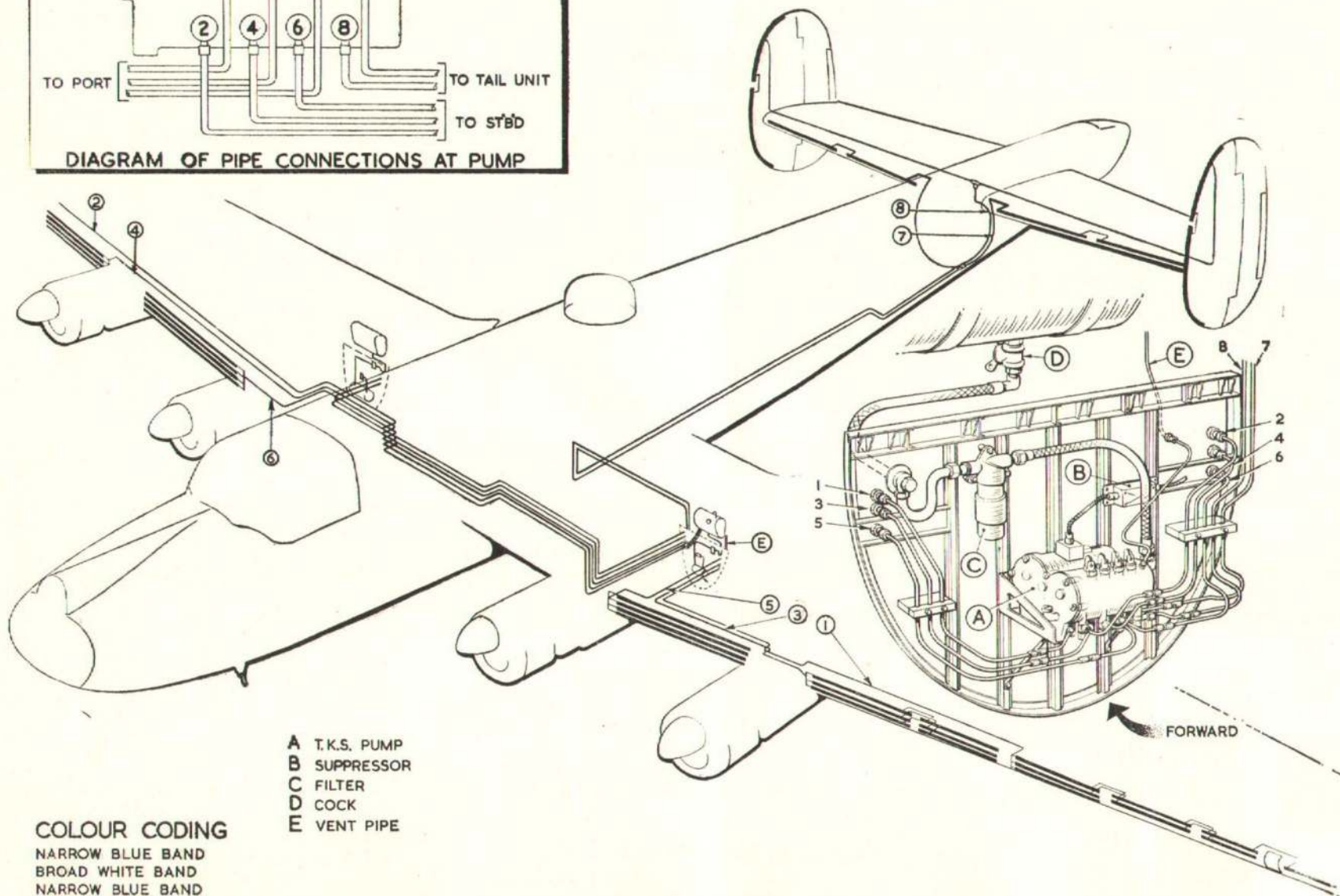
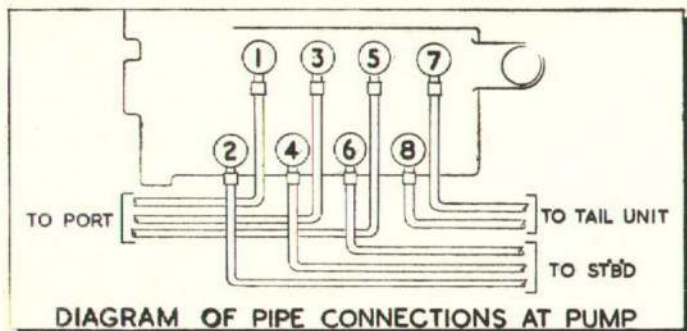

- A T.K.S. PUMP
- B SUPPRESSOR
- C FILTER
- D COCK
- E VENT PIPE

COLOUR CODING

- NARROW BLUE BAND
- BROAD WHITE BAND
- NARROW BLUE BAND

Fig. 1A. Aerofoil de-icing system (1)

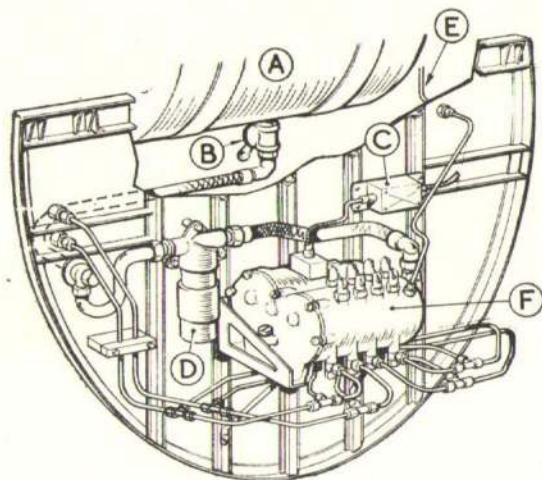

TRANSFER PUMP INSTALLATION

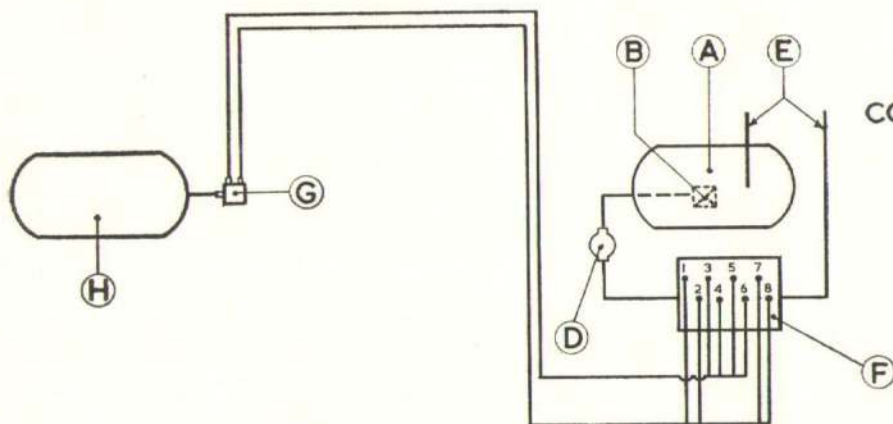
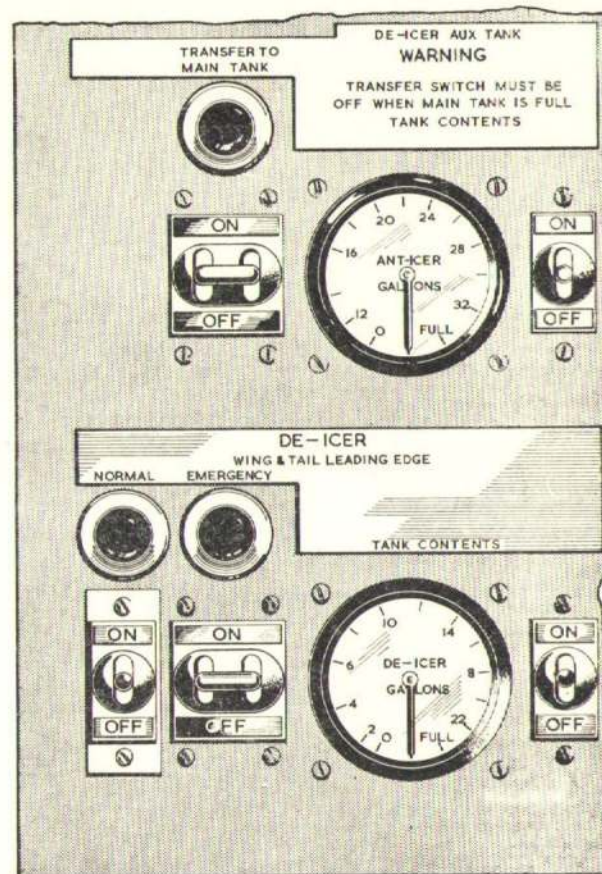

DIAGRAM OF TRANSFER SYSTEM



CONTROLS ON FLIGHT ENGINEER'S AUXILIARY PANEL

- A AUXILIARY DE-ICING TANK
- B CONTROL COCK
- C SUPPRESSOR
- D FILTER
- E VENT PIPES
- F T.K.S. PUMP
- G MANIFOLD
- H AEROFOIL DE-ICING TANK

Fig. 2A. Aerofoil de-icing system (2)

RESTRICTED



This file was downloaded
from the RTFM Library.

Link: www.scottbouch.com/rtfm

Please see site for usage terms,
and more aircraft documents.

