

Chapter I.—POWER UNIT

LIST OF CONTENTS

DESCRIPTION AND OPERATION	Para.	DESCRIPTION AND OPERATION	Para.
Introduction	1	Radiator flaps	27
Power plants		Engine and propeller controls	28
Cowling	2	Control pedestals	29
Cowling aft of firewalls (inboard)	3	Control lever locking device	30
Cowling aft of firewalls (outboard)	4	Controls in fuselage	31
Power plant mountings		Controls on front spar	32
Undercarriage beams	5		
Inboard sub-frames	7	SERVICING	
Outboard sub-frames	8	Introduction	33
Firewalls	9	Ground equipment and special tools for servicing	34
Nacelles		Pipe systems and control markings	35
Wheel compartments		Engine and propeller control settings	36
Valances	11	Setting front spar levers relative to cockpit controls	37
Undercarriage doors	12	Adjusting the lengths of the firewall countershaft levers	38
Engine ribs	13	Setting the firewall countershaft levers and connecting up	39
Rear nacelle fairings		Connecting the pantographs	40
Inboard	14	Propellers	
Outboard	15	Servicing	41
POWER PLANT SYSTEMS AND ACCESSORIES		Feathering tests	42
Cooling systems	16	Cooling systems	43
Power plant accessories		Lubrication	
Drive transmission	17	Engine controls	44
Accessories	18	Accessory drives	45
Cooling—d.c. generators and air compressors	19	Servicing points	46
Water/methanol system	21	Propellers	47
POWER PLANT CONTROLS	22	Power plant gantry	48
Superchargers	23	Removing and fitting power plants	49
Slow-running cut-outs	24	Power plant attachment assemblies	50
Air cleaners	25	Removal of a power plant	52
Charge temperature control	26	Installation of a power plant	53
		Nacelle structure and accessories	54

LIST OF TABLES

DESCRIPTION	Table
Gear box accessories (para. 18)	1
List of associated publications (para. 33)	2
Power plant attachment assembly components (fig. 18)	3

LIST OF ILLUSTRATIONS

DESCRIPTION	Fig.
Power plant cowlings—port inboard	1
Power plant cowlings—port outboard	2
Securing Dzus fasteners—1	3
Securing Dzus fasteners—2	4
Securing Dzus fasteners—3	5
Securing Dzus fasteners—4	6
Inboard power plant sub-frame	7
Outboard power plant subframe	8
Rear nacelle fairings	9
Auxiliary units and gearboxes	10
Engine controls—1	11
Engine controls—2	12
Engine controls—3	13
Engine controls angular movements—control pedestals	14
Engine controls angular movements—firewalls	15
Engine controls settings—inboard	16
Engine controls settings—outboard	17
Power plant attachment assembly	18
Engine oil supply connection	19
Erection of power plant gantry	20
Firewall details—1	21
Firewall details—2	22
Power plant slinging	23
No. 2 and No. 3 accessories gearboxes	24
No. 1 and No. 4 accessories gearboxes	25
Rear nacelle fairings	26
Removal of inboard sub-frame	27
Removal of outboard sub-frame	28

DESCRIPTION AND OPERATION

INTRODUCTION

1. The four Griffon 57 engines which power the aircraft are housed in power plants (E) to form quickly detachable units. Each power unit drives a counter-rotating propeller (*Leading Particulars*). Single-stage, two-speed superchargers are embodied and a separate water/methanol fuel system (*described in Chapter 2*) gives increased maximum boost. Reference should be made to the list of Associated Air Publications at the beginning of this Volume which deal with the propellers and power plant, although the salient features of the latter are described in the following paragraphs.

POWER PLANTS

Cowling

2. The front of each power plant is cowled by two detachable panels which fit between the front diaphragm and the forward intermediate cowling ring. The lower of these two cowlings is further shaped to provide a semi-circular air-intake and radiator scoop. There is a second intermediate cowling ring between the forward ring and the firewall and, at the top between the two rings, is a top panel which is hinged along its fore-and-aft centre line. Supporting props are provided to enable either side, or both sides, to be maintained in the raised position to facilitate engine servicing, without removing the panel. Below this panel, two detachable fairing panels which cover the radiators, are located immediately aft of the front intermediate cowling ring. Aft of these are two flaps which control the passage of air through the radiator and oil-cooler duct. These, in turn, are followed by two detachable side panels which are shaped to form part of the duct outlet and finish at the rear cowling ring. Between this ring and the firewall are fitted a top

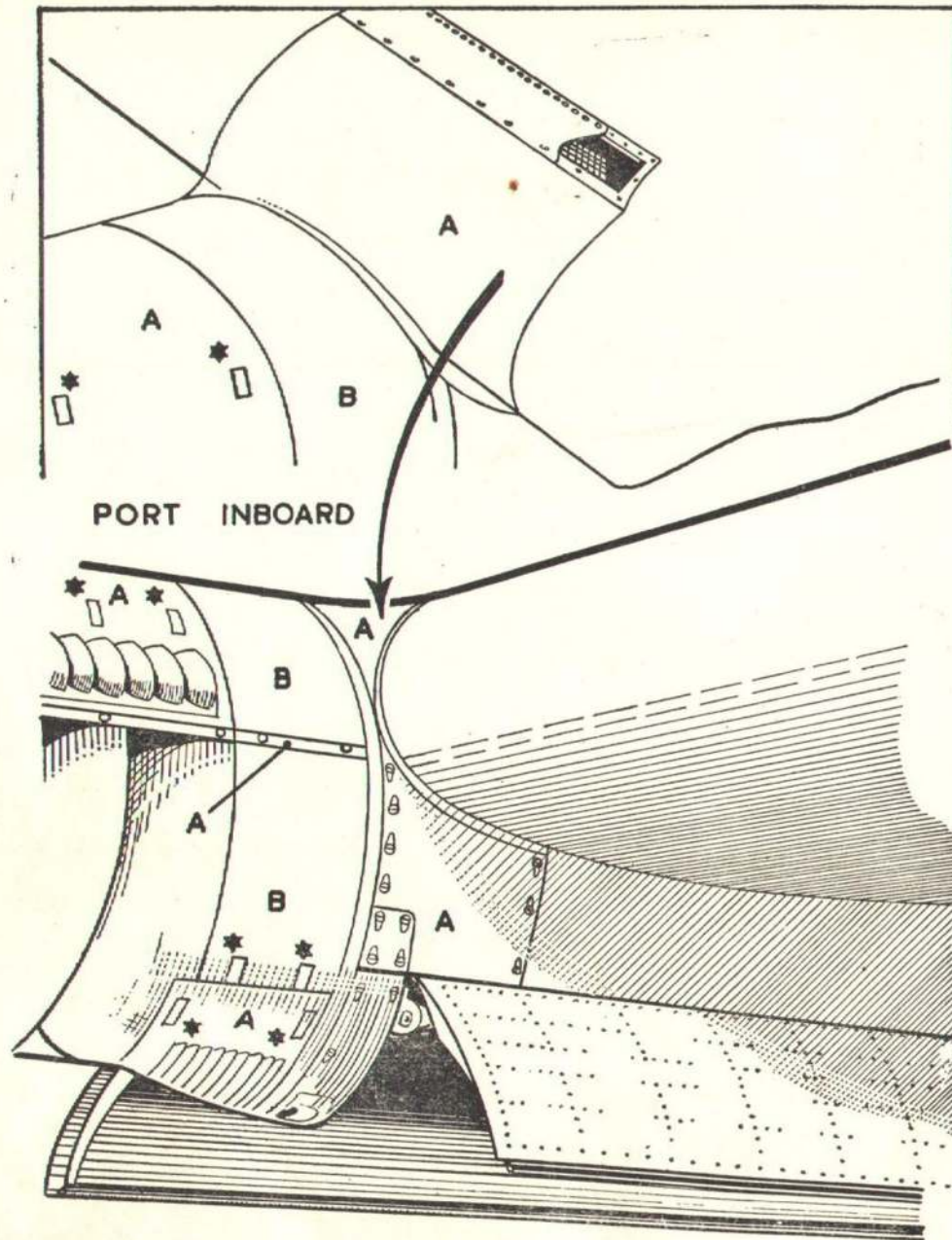

Fig. 1. Power plant cowlings—port inboard

Note . . .

Fig. 1
Panels marked 'B' cannot be released until panels marked 'A' have been removed. Refer to A.P. 4275A, Vol. 1, for full description of power plant cowlings.

RESTRICTED

half-panel, two small panels below it on each side and an under panel covering the air cleaner and projecting forward of the aft intermediate cowling ring. All these panels are detachable. The attachment points on all cowling panels are provided with quick-release fasteners.

Cowling aft of firewalls - inboard (fig.1)

3. Two top, two side and a bottom panel enclose the sub-frame aft of the firewall. The forward top panel is of sheet steel and the remainder of light-alloy sheet. All panels are stiffened by angle-section members at the edges with intermediate top-hat-section stiffeners and are secured by quick-release fasteners. The top panel is narrow and fits between the top of the spar and the front panel rear edge. Both side panels extend aft to the wheel compartment, the bottom panel is relatively short and extends to the undercarriage doors.

Cowling aft of firewalls - outboard (fig.2)

4. The forward part of the sub-frame is enclosed by five panels in a similar manner to the inboard sub-frame. The top front panel is of steel, the remainder are of light-alloy sheet. All panels are reinforced by angles at the edges and by intermediate top hat section stiffeners, they are secured by quick-release fasteners.

POWER PLANT MOUNTINGS

Undercarriage beams (fig.7)

5. The inboard engine sub-frames are each supported by a pair of cast light-alloy beams having six integral lugs or forks to which the sub-frames are bolted. At the lower end of each beam is a milled fork which serves as an attachment point for the upper end of the associated main wheel unit shock-absorber strut. A lug on

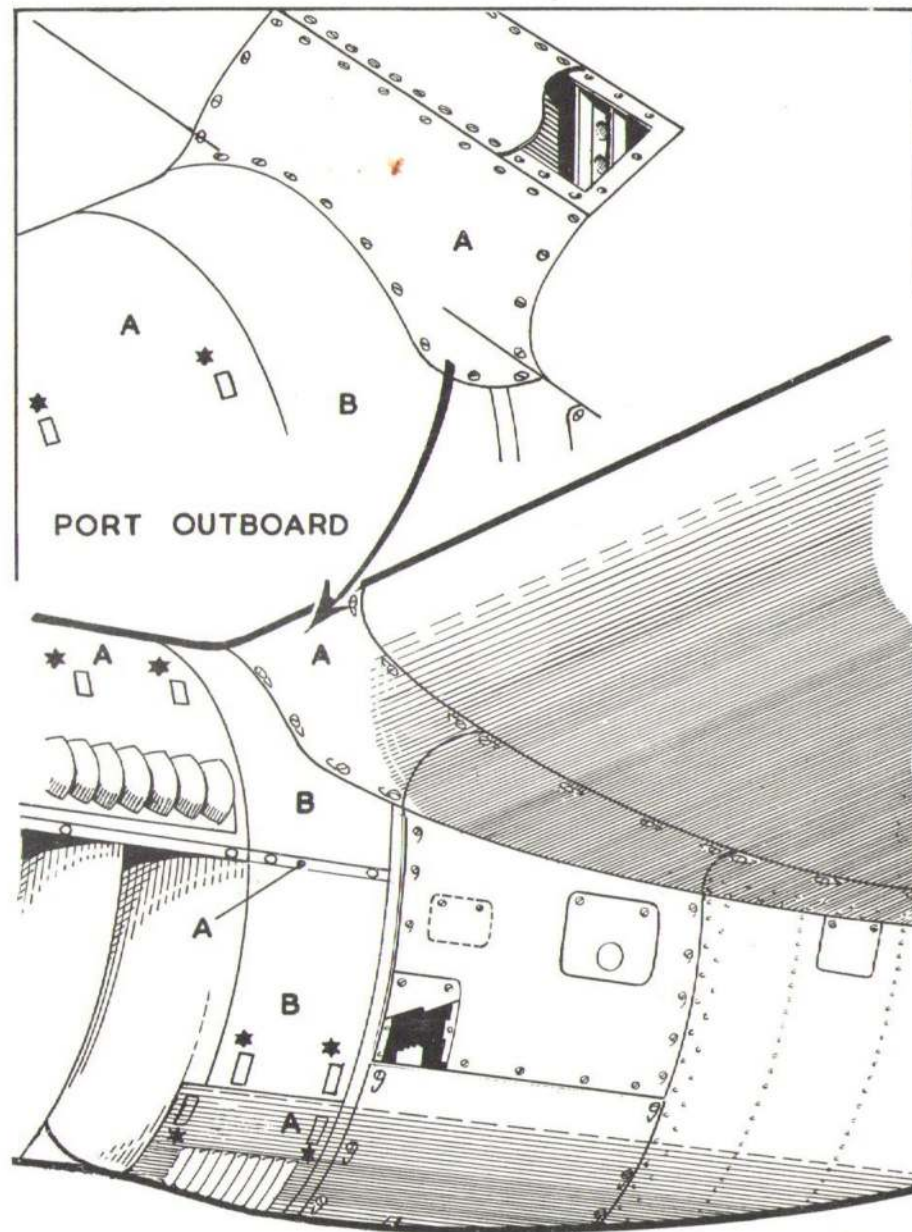

Fig.2

NOTE...

Panels marked "B" cannot be released until the panels marked "A" have been removed. Refer to A.P.4275A, Vol.1 for full description of power plant cowlings.

Fig.2. Power plant cowlings - port outboard

RESTRICTED

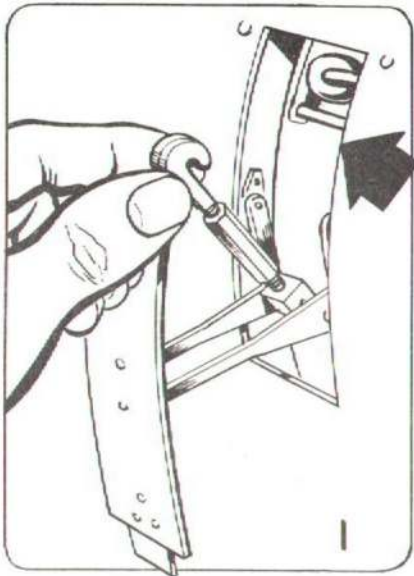

Fig. 3. Securing Dzus fasteners - 1

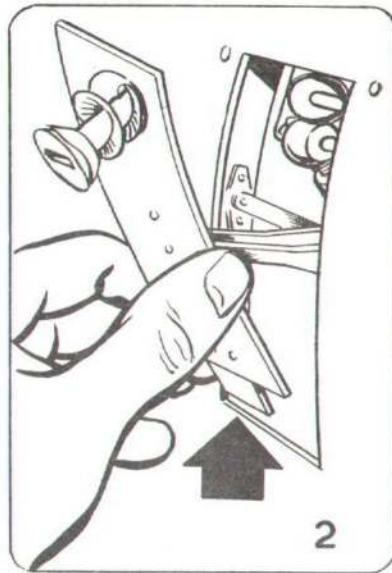

Fig. 4. Securing Dzus fasteners - 2

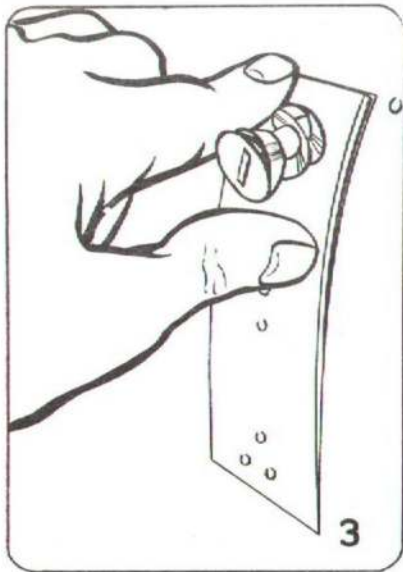

Fig. 5. Securing Dzus fasteners - 3

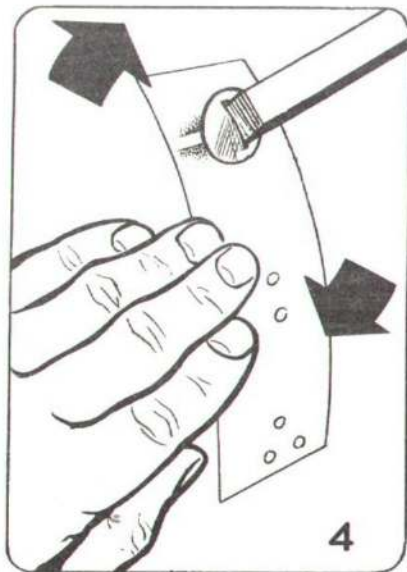

Fig. 6. Securing Dzus fasteners - 4

the inside face of each beam forms the attachment point for one end of a diagonal bracing strut. The bolts attaching the main wheel shock-absorber struts screw into the horizontal K-bracing strut of the main wheel unit.

6. The beams are each secured to the main plane front spar boom by two bolts which also secure the associated engine rib, and intermediately to the spar web by smaller bolts. The top of each beam incorporates a pad which permits attachment of a power plant changing gantry.

Inboard sub-frames (fig.7)

7. These are of welded steel tube construction to ensure rigidity. The engine bearer assembly of each power plant has four rearward projecting forks which are secured to corresponding lugs at each corner of the front of each sub-frame. An auxiliary vertical tubular member is clipped to the upper and lower member of the front of each sub-frame to carry an accessories gearbox mounting plate, which is clipped to this member and the port front vertical strut of the sub-frame proper.

Outboard sub-frames (fig.8)

8. These are of welded steel tube cantilever construction and each embodies an integral bush in each of its upper forward side-members, by which it is attached to two channel-type mounting brackets fitted on the forward face of the main plane front spar. At the rear end of the sub-frame, where the four rear tubes meet at a point and are welded to a short tubular member, is a fork integral with this member. A channel-type bracket, to which the fork is bolted, is likewise bolted to the lower boom of the rear spar and to the aft end of rib 7A of the associated intermediate main plane section. At the front of the sub-frames are four forks to which corresponding lugs of the power plant are bolted.

FIREWALLS

9. The firewalls are ovoid in shape and are clipped to the front frame of each sub-frame. They are illustrated in fig.21 and 22 and consist of a central, vertical, 22-gauge tinned steel plate flanked by two half-moon shaped plates of the same material. The two vertical joints are made by two riveted top-hat-section stiffeners on the forward face, except at the bottom where a small portion of each joint is effected by a short length of the same section on the aft face. Transverse top-hat-section stiffeners are provided as shown in the illustrations. The identical shape of the firewalls allows interchangeability of all four power plants.

10. The power plant connections are

mounted on the firewall. Sealing plates, with asbestos packing, are fitted at the points where the power plant attachment forks on the sub-frames pass through the firewall. Sealing boxes, through which pass the engine and propeller speed control rods from the main plane front spar to a layshaft at the top of the front face of each firewall, are attached to the aft face. These boxes have two sliding sealing-glands in their aft faces through which the control rods pass.

NACELLES**Wheel compartments***Valances*

11. These are described in Sect.3, Chap.5, and form the inboard nacelle intermediate fairing under the main plane, aft of the detachable cowling. The forward end of the channel-section upper edge member of each valance projects forward to the firewall, to which it is bolted, and forms a securing rail for the cowling.

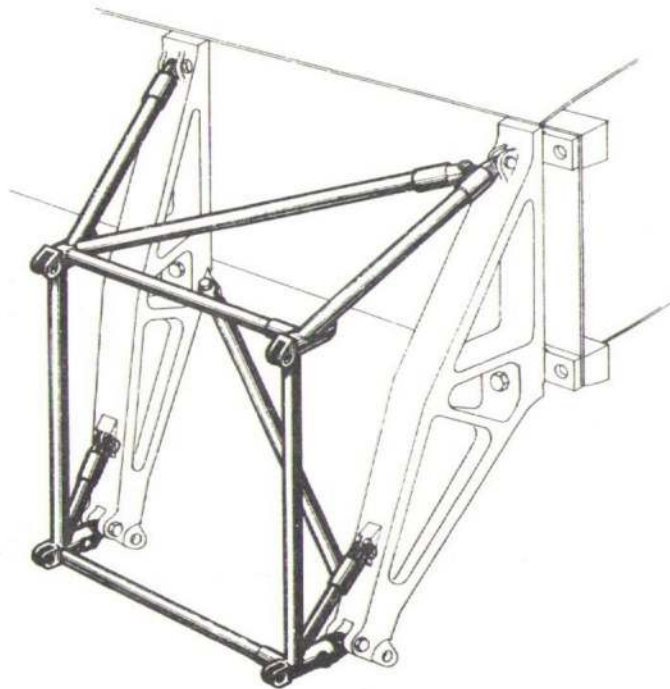

Fig.7. Inboard power plant sub-frame

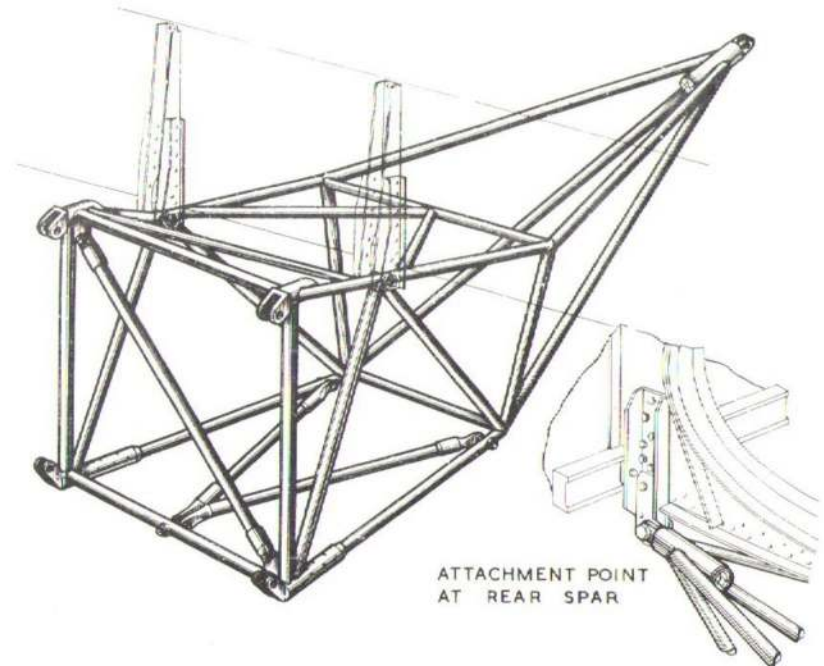

Fig.8. Outboard power plant sub-frame

RESTRICTED

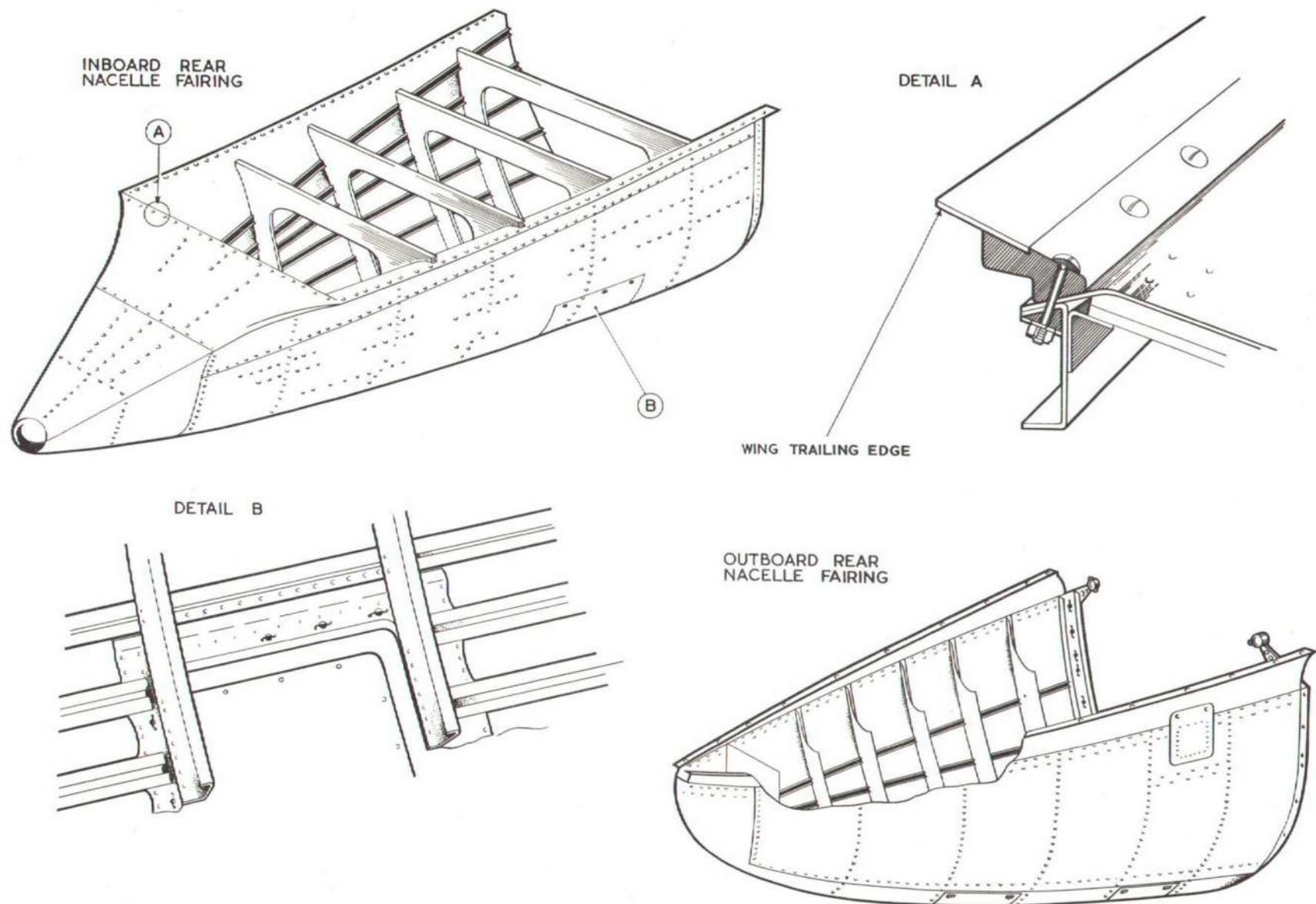

Fig.9. Rear nacelle fairings

RESTRICTED

Undercarriage doors

12. When closed, the doors complete the intermediate portion of the inboard nacelle fairing below the valances. They are longer than the valances at their forward ends and the small space between the firewall and the doors is faired over by the narrow bottom detachable panel. Refer to Sect.3, Chap.5.

Engine ribs

13. These are described in Sect.3, Chap.2, and form the sides of the wheel compartments. The inboard side of each inner engine rib is covered by a diaphragm of light-alloy sheet to exclude dirt from the No.1 fuel tanks.

REAR NACELLE FAIRINGS (fig.9)**Inboard**

14. The inboard nacelles to the rear of the undercarriage valances and doors are faired into the main plane and extend beyond its trailing edge. The fairings consist of light-alloy skin riveted to top-hat section stringers and pressed, channel-section formers. An access door, secured by quick-release fasteners, is situated at the forward end of the underside (aft of each main wheel compartment rear bulkhead). The fairing is bolted through its flanged upper edges and through its forward edge to the underside of the main plane trailing edge and to the rearward flanged edge of the associated wheel compartment rear bulkhead. This bulkhead is of light-alloy sheet attached to an angle-section former with channel and top-hat section stiffening members.

Outboard (fig.9)

15. Fairing of the outboard nacelles is completed by a light-alloy fairing skin supported by seven formers. Attachment flanges at the upper edges are formed by curved and tapering fillets riveted to the edges of the plating. The edges of the fillets are attached to the underside of the main plane by quick-release fasteners. At its forward end, each fairing is bolted

at the top of the former to clips on the sub-frame tubing. Mod.1000 introduces strengthened nacelle fairings to cater for the introduction of the extended exhaust system.

POWER PLANT SYSTEMS AND ACCESSORIES**COOLING SYSTEMS**

16. The cooling system is described in Chapter 4 of this Section.

POWER PLANT ACCESSORIES**Drive transmission**

17. At the rear of each engine, on the starboard side, is an accessories gearbox drive shaft which is coupled to a shaft incorporating a universal joint. The shaft is in turn coupled to the starboard side of an off-set drive assembly mounted on the forward face of the firewall. This assembly consists of a transverse shaft with a bevel gear wheel at each end. These two gears each mesh with another bevel gear wheel to give a drive at right-angles to the transverse shaft at unit speed ratio, with a short shaft projecting at each end, one forward to starboard, and one aft to port, when the assembly is in position. The whole of this mechanism, except for the ends of the fore-and-aft shafts, is enclosed in an oil-tight casing and oil is fed by a pipe from the associated accessories gearbox to a union at the approximate mid-point of the casing. Excess oil is drained out of the port end

of the assembly, past the gearbox drive shaft, back into the gearbox, thus providing a forced-feed lubrication system. Detailed information is contained in A.P. 2240A.

Accessories (fig.10)

18. The inboard gearboxes each have six driving faces, and there are four on each outboard gearbox, although in some instances all faces are not utilised. Each gearbox drives accessories as detailed in Table 1.

Cooling - d.c. generators and air compressors

19. These accessories are cooled by air which is ducted from an opening in the bottom of each nacelle. A light-alloy scoop is riveted to the bottom of the rear face of each firewall with the face containing the opening projecting below the bottom cowling panel.

20. On the inside of this face is riveted a flanged piece of light-alloy tube having a diameter of two and a half inches. This tube extends upwards behind the sump of the gearbox and then branches; one branch leading to the cooling inlet at the top of the generator and the other to a light-alloy jacket surrounding the fins of the air compressor. This jacket has outlet holes at its upper end. Air is forced into these cooling systems by the pressure created by the airflow under the inclined bottom cowling.

TABLE 1

No.1 Port outboard	No.2 Port inboard	No.3 Starboard inboard	No.4 Starboard outboard
Generator - 6Kw. Tachometer generator	Generator - 6Kw. Tachometer generator Air compressor Vacuum pump	Generator - 6Kw. Tachometer generator Air compressor Vacuum pump Hydraulic pump	Generator - 6Kw. Tachometer generator Hydraulic pump

RESTRICTED

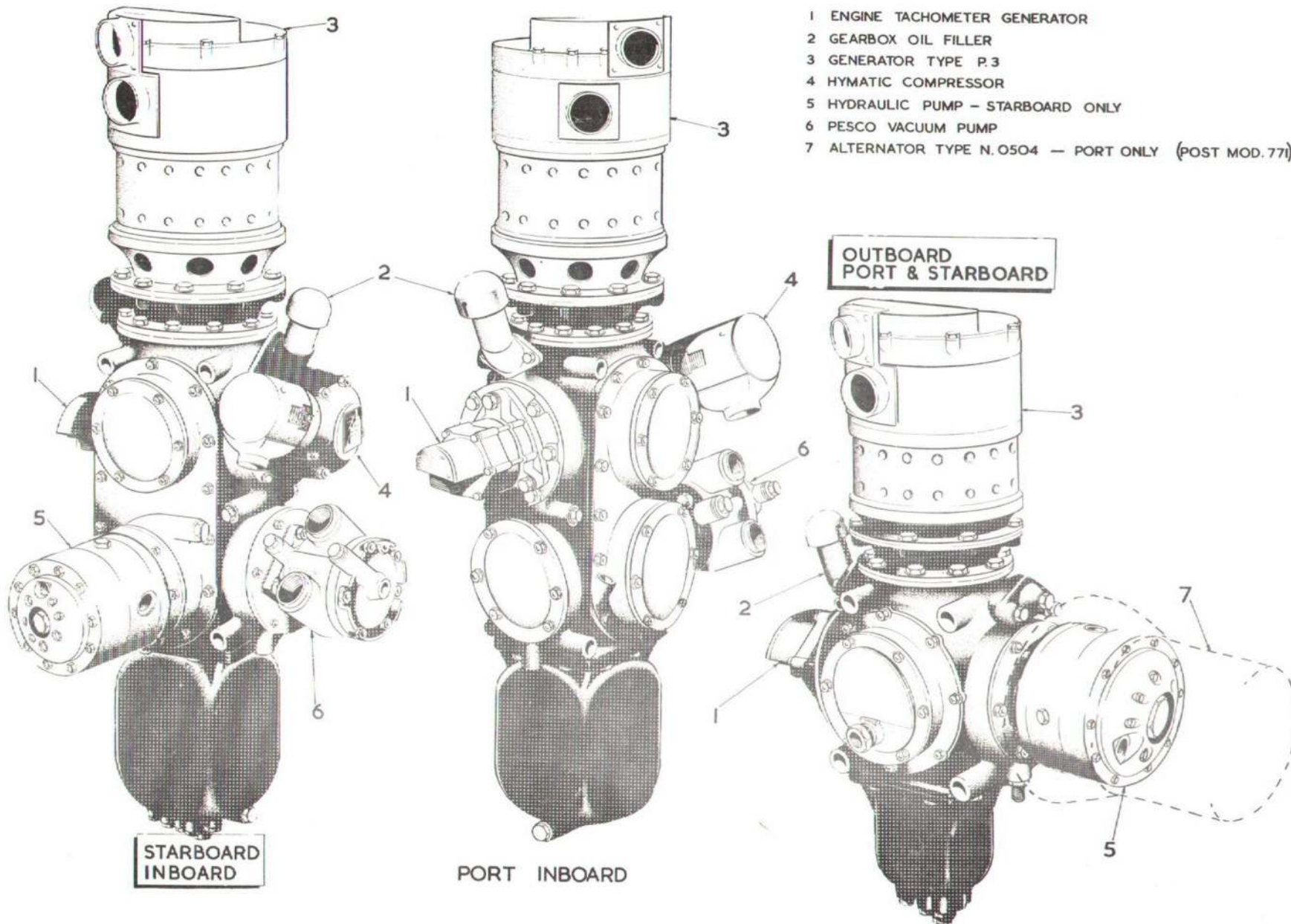

Fig.10. Auxiliary units and gearboxes

RESTRICTED

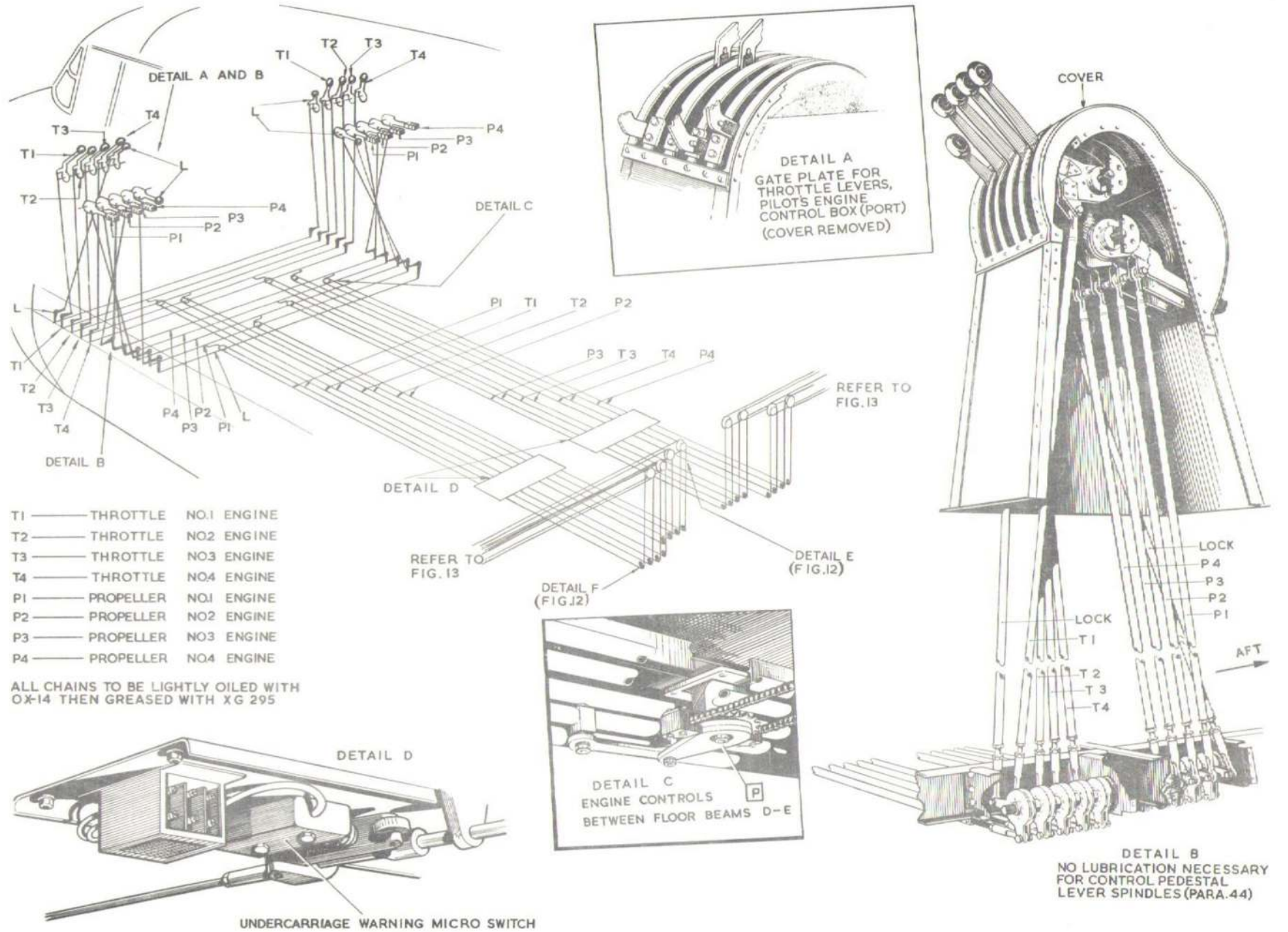

Fig.11. Engine controls

RESTRICTED

WATER/METHANOL SYSTEM

21. Injection of water/methanol fluid (Leading Particulars) is used at boost pressures above 18 lb. per sq.in. (nominal) up to the maximum of 25 lb. per sq.in. obtainable on the Griffon Mk.57 engine (refer to A.P.2234E, Vol.1). The associated airframe system is described in Chapter 2 of this section.

POWER PLANT CONTROLS

22. Description of the power plant controls given in the following paragraphs refer only to the control systems in the airframe. Refer to A.P.4275A, Vol.1, for location and description of these controls in the power plant.

SUPERCHARGERS

23. The two speed superchargers embody oil-operated clutches, the oil supply taken from the pressure side of the engine oil pumps, being controlled by an electric solenoid valve located at the rear of each engine. The valve solenoids are energised through a switch, common to all four, on the flight engineer's main panel which also incorporates four red warning lamps to indicate when F.S. gear is engaged. At the side of the control switch is mounted another switch to which it is ganged. This switch controls the the water/methanol system.

SLOW RUNNING CUT-OUTS

24. These are operated by solenoids controlled by centre-off switches, one to each engine, mounted on the flight engineer's auxiliary panel. The four switches are normally in OFF (engine running) position, but, by moving the toggles down to the SLOW RUNNING CUT-OFF - ON position, the slow running cut-offs are operated. When the toggles are moved up, the ignition booster coils are switched ON.

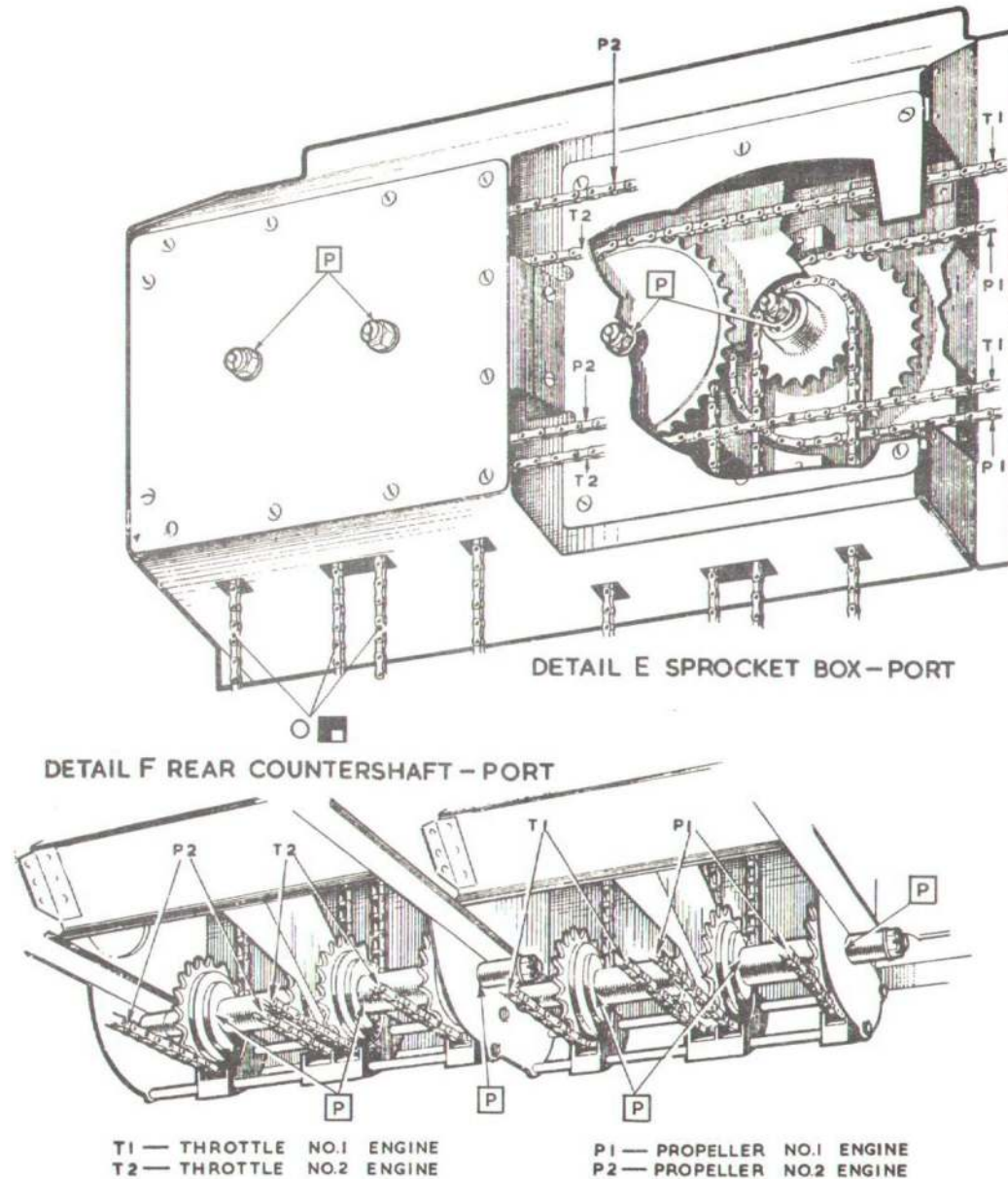

Fig.12. Engine controls - 2

RESTRICTED

AIR CLEANERS

25. Electro-pneumatic control is used for the air cleaner units, a ram operates a flap which seals off the forward portion of the intake system and causes air to be drawn through filters at each side of the aft part of the system. The pneumatic ram valve is controlled by a switch, labelled NORMAL and CLEAN AIR, on the flight engineer's main panel. When CLEAN AIR is selected the ram closes the flap. Electrical failure causes the flap to assume the normal air position.

CHARGE TEMPERATURE CONTROL

26. Hot air which has passed through the radiators into the power plant, is admitted into the main intake duct by hot-air intake flaps, one on each side of the front portion of the air-intake system. The intake of varying proportions of hot and cold air is effected by altering the setting of these flaps. Automatic control is provided by an electro-pneumatic system, controlled by a thermostat in conjunction with an inching unit. The four systems are operated by four, 4-position switches on the flight engineer's main panel labelled AUTO-COLD-STOP-HOT. In the event of electrical failure, the ram concerned remains set in the position selected at the time of failure.

RADIATOR FLAPS

27. The position of these flaps is normally controlled automatically by an electro-pneumatic inching unit, but positional selection can be made by use of one of four, 4-position switches on the pilot's panel labelled AUTO-OPEN-STOP-CLOSE. In the event of electrical failure the flaps assume a position which allows sufficient cooling to prevent overheating of the engine concerned.

ENGINE AND PROPELLER CONTROLS

28. The engine and propeller control levers are grouped in positional sequence on two control pedestals, one on the port side, and one on the starboard side of the first and second pilots seats respectively.

CONTROL PEDESTALS

29. Both pedestals incorporate four throttle-control levers and four propeller control levers, each set, on each pedestal being assembled on a common shaft. The ends of the levers are provided with plastic knobs. Connected to the levers, inside each pedestal, are eight push-pull rods which are in turn connected to the control system beneath the floor skin.

CONTROL LEVER LOCKING DEVICE

30. At the inboard end of each shaft carrying four controls is a damping lever with a boss which forms a bearing for the lever on the shaft. This boss has, on its inboard face, two cams which are coincident with two recesses on a similar boss fitted to the pedestal when the levers are in the undamped or free position. When the lever is moved, the cams on the lever boss progressively ride out of the recesses on the boss on the side of the pedestal, moving the lever along the shaft, on which it is free fitting and compressing the four control lever bosses and their associated friction discs until sufficient friction is created to lock the levers.

CONTROLS IN FUSELAGE (fig.11 and 12)

31. The lower ends of the push-pull rods in the pedestals are connected by bell-cranks to transverse push-pull rods which are adjustable to permit synchronisation of the levers on both pedestals. Lateral movement of these transverse push-pull rods is transmitted to sprockets by links. From each sprocket, the movement is transmitted aft by chains and tie-rods. The fore-and-aft movement of the tie-rods is transmitted by chains round sprockets located at the bottom of the forward face of the front spar, and upwards to layshaft assemblies which are protected by light-alloy casings and mounted on the forward face of the front spar. Each casing has two detachable panels giving access to the layshaft for servicing. Four micro-switches, operated by cams integral with the fore-and-aft tie rods, are mounted under the front centre section

floor as shown in the illustration (detail D, fig.11). The switches control the undercarriage warning systems.

CONTROLS ON FRONT SPAR (fig.13)

32. From the layshaft assemblies, the controls branch outwards along the front face of the front spar. The inboard engine controls lead to sprocket boxes with two sets of idler sprockets, at which the controls turn upwards and finish at an integral assembly of two sprockets and levers. Push-pull rods transmit the movement to bell-crank assemblies on the firewalls from which connections are made to the engine pantographs. These are described in A.P.4275A, Vol.1. The controls to the outboard power plants continue across the inboard nacelles to layshaft assemblies (fig.13, detail A), at each outboard undercarriage beam which give the necessary change of direction caused by the sweepback of the mainplane leading edge at this point. The run of the controls from this point to each outer nacelle firewall is similar to that of each inboard nacelle.

SERVICING

Introduction

33. The servicing information given in this chapter deals only with overall procedures not described in associated Air Publications. Reference should be made to the A.P.'s quoted in Table 2 or at the front of this volume.

TABLE 2

List of associated publications

Instrument Manual - general instruments	A.P.1275A
Aero-engines and power plants	A.P.1464A
Ground equipment	A.P.1464G
de-Havilland counter-rotating variable pitch propellers ...	A.P. 1538K
Griffon Mk.57 aero-engines ...	A.P.2234D
Rotol accessory gearboxes and drives	A.P.2240A
Electro-pneumatic and electro-hydraulic control equipment	A.P.4152A
Griffon Mk.57 power plant (E)	A.P.4275A

RESTRICTED

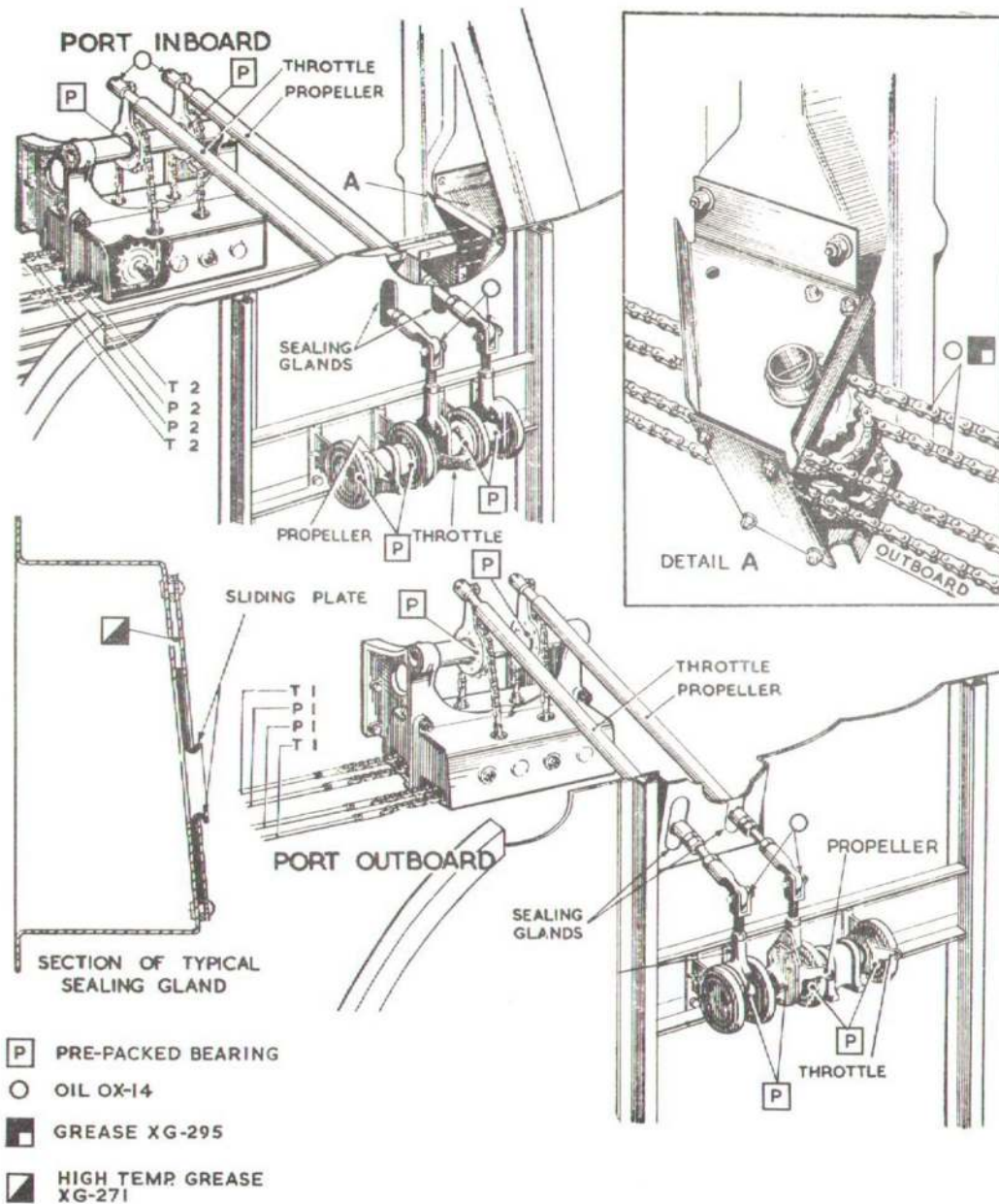

Fig.13. Engine controls - 3

GROUND EQUIPMENT AND SPECIAL TOOLS FOR SERVICING

34. A list of all special equipment and tools, together with the standard equipment and tools, necessary for servicing is given in Section 2, Chapter 4 of this volume.

PIPE SYSTEMS AND CONTROL MARKINGS

35. These are given in Section 2, Chapter 4, and on all illustrations of piping systems.

ENGINE AND PROPELLER CONTROL SETTINGS (fig.14 to 17)

36.

NOTE...

Where the vertical position of certain levers is mentioned in the following paragraphs, the aircraft is assumed to be in the rigging position. The front spar web and the firewalls are vertical in this position. (Section 2, Chapter 4).

SETTING THE FRONT SPAR LEVERS RELATIVE TO COCKPIT CONTROLS

37.

- (1) Set all control levers on both control pedestals in the mid-travel position.
- (2) Inboard nacelle levers on front spar. Set these levers to the mid-travel position as follows:-

Throttle lever... 4 deg. forward of vertical
 Propeller lever... 5 deg. forward of vertical

- (3) Outboard nacelle levers on front spar. Set these levers to the mid-travel position as follows:-

Throttle lever... 28 deg. forward of vertical
 Propeller lever... 29 deg. forward of vertical

- (4) Chains and tie-rods between (2) and (3). Connect or adjust all chains on relevant sprocket with all ends approximately equidistant from their associated sprockets. Attach all tie-rods and adjusters; take up all slack.

RESTRICTED

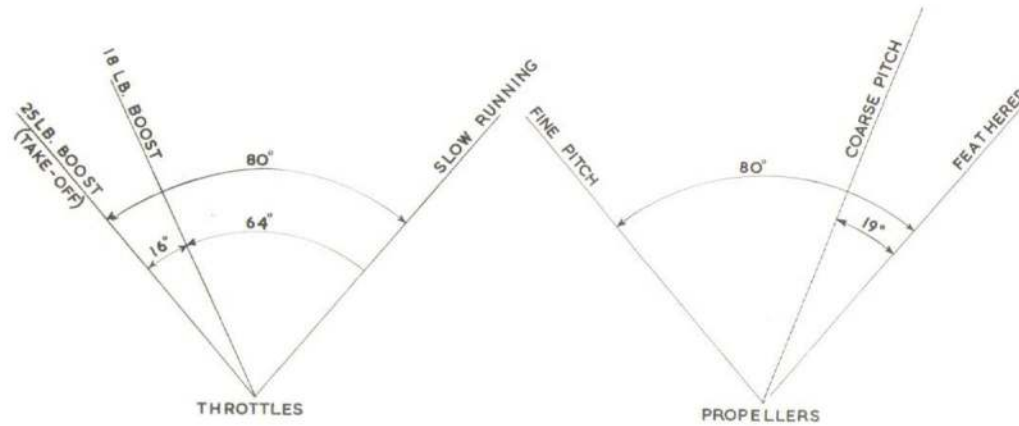

Fig.14. Engine controls angular movements - controls pedestals.

Adjusting the lengths of the firewall countershaft levers

38. If the lengths of these levers have not been previously disturbed, the existing settings should be retained. Otherwise, as a preliminary measure, the throttle and propeller levers should be adjusted to lengths of $4\frac{5}{8}$ in. and $4\frac{3}{16}$ in. respectively, measured from the centre of the shaft to the centre of the connecting-rod attachment.

Setting the firewall countershaft levers and connecting up

39. Set the levers in the mid-travel position as follows:-

- (1) Inboard firewalls:-

Throttle lever ...	4 deg. forward of vertical
Propeller lever ...	6 deg. forward of vertical
- (2) Outboard firewalls

Throttle lever ...	$27\frac{1}{2}$ deg. forward of vertical
Propeller lever ...	$29\frac{1}{2}$ deg. forward of vertical

- (3) Fit the connecting-rods between the front spar levers and the firewall levers, adjusting the rod lengths to suit the pre-set positions of the levers.

Connecting the pantographs

- (1) Pull the control levers in the

cockpit to the fully-back position and set the control levers on the engine against the rear stop.

- (2) Connect each pantograph to the relative countershaft levers.
- (3) Reduce the length of the adjustable levers on each firewall countershaft sufficiently to cause the relevant levers in each pilot's pedestal to spring forward $\frac{1}{4}$ in. to $\frac{1}{2}$ in., when the control levers are drawn back to the end of their quadrant and then released.
- (4) Move the pedestal levers fully forward and check that each engine lever is against the forward stop. (The engine levers may be checked at the forward and rear stops by ascertaining whether a thin piece of paper can be trapped against each stop by the lever).
- (5) Make any necessary adjustments on the control connections on the engines. If necessary, make further adjustments to the lengths

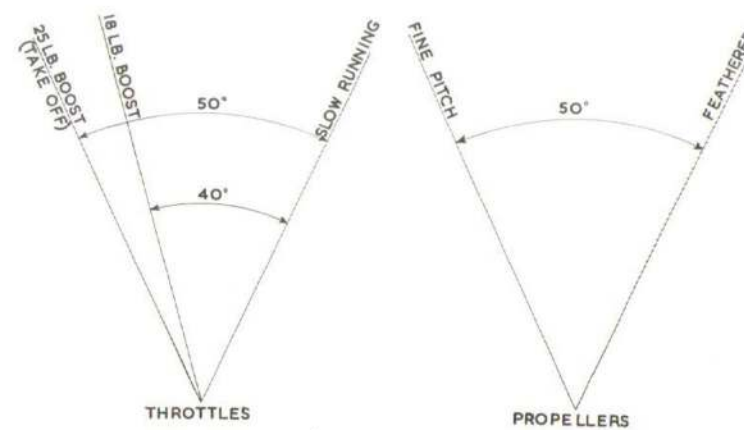

Fig.15. Engine controls angular movements - firewalls.

RESTRICTED

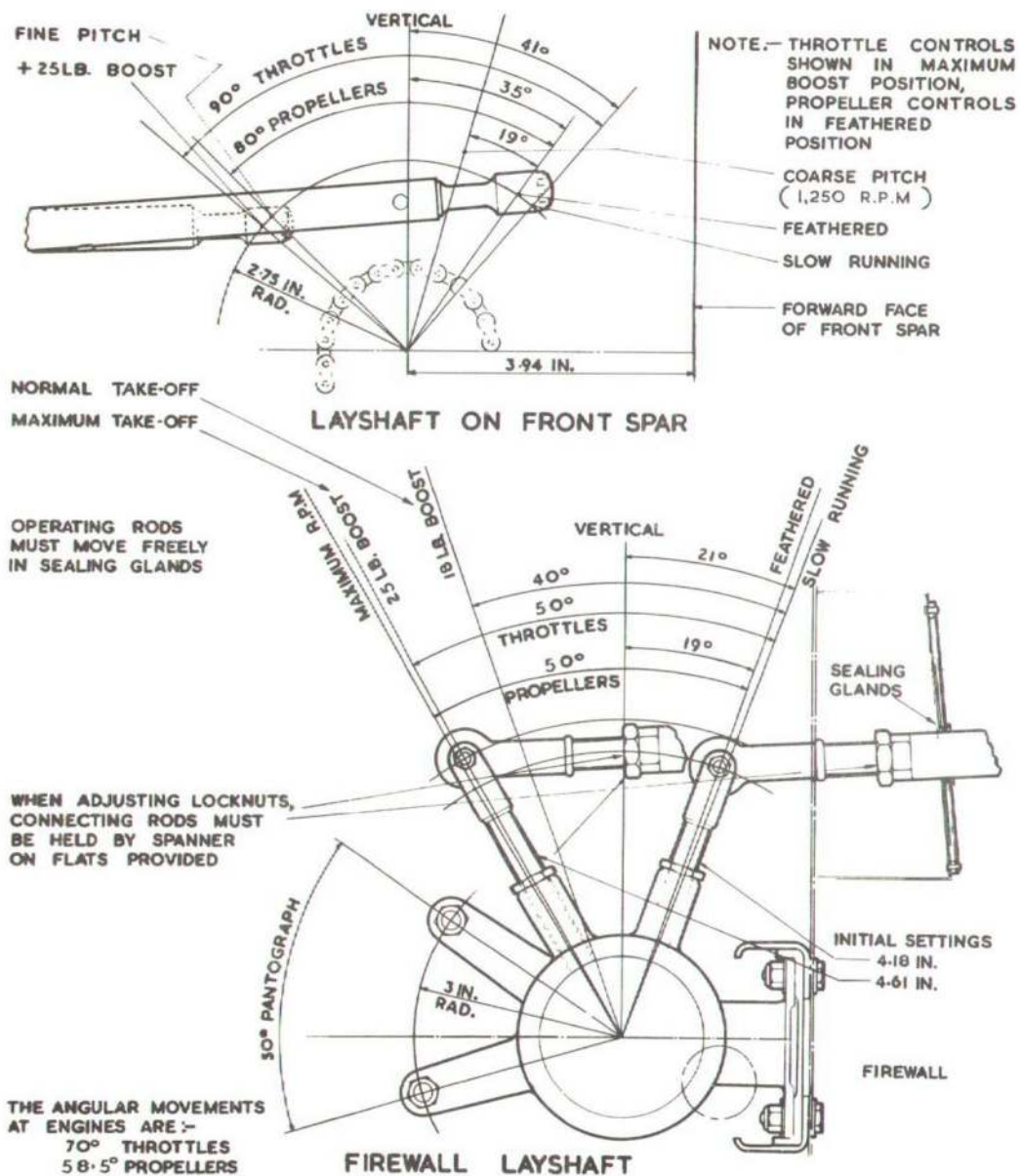

Fig.16. Engine controls settings - inboard.

of the levers on the firewall countershafts and to the lengths of the connecting rods between these countershafts and the front spar levers.

PROPELLERS

Servicing

41. Full information on servicing, including general lubrication, draining, and filling the translation unit tank, is given in A.P.1538K, Vol.1.

Feathering tests

42. When these tests are carried out on the ground, a fully-charged external battery must be used. Failure to use a fully-charged battery may result in damage to the switch solenoids.

COOLING SYSTEMS

43. Refer to Chap.4 of this section.

LUBRICATION

Engine controls

44. All joints are to be lubricated with oil OX-14. All chains are to be lightly oiled with OX-14, and then greased with XG-295. It is most important to note that no lubrication is necessary for the control pedestal lever spindles. Oil applied to the lever bosses or spindles would render the locking devices non-effective.

Accessory drives

45. The type of oil for the gearbox and enclosed cross-drive shaft is given in the Leading Particulars. Servicing details for this equipment are given in A.P.2240A, Vol.1.

SERVICING POINTS

46. Reference should be made to the relevant illustration in Section 2, Chapter 2. The positions of all access panels are given in Section 2, Chapter 4.

RESTRICTED

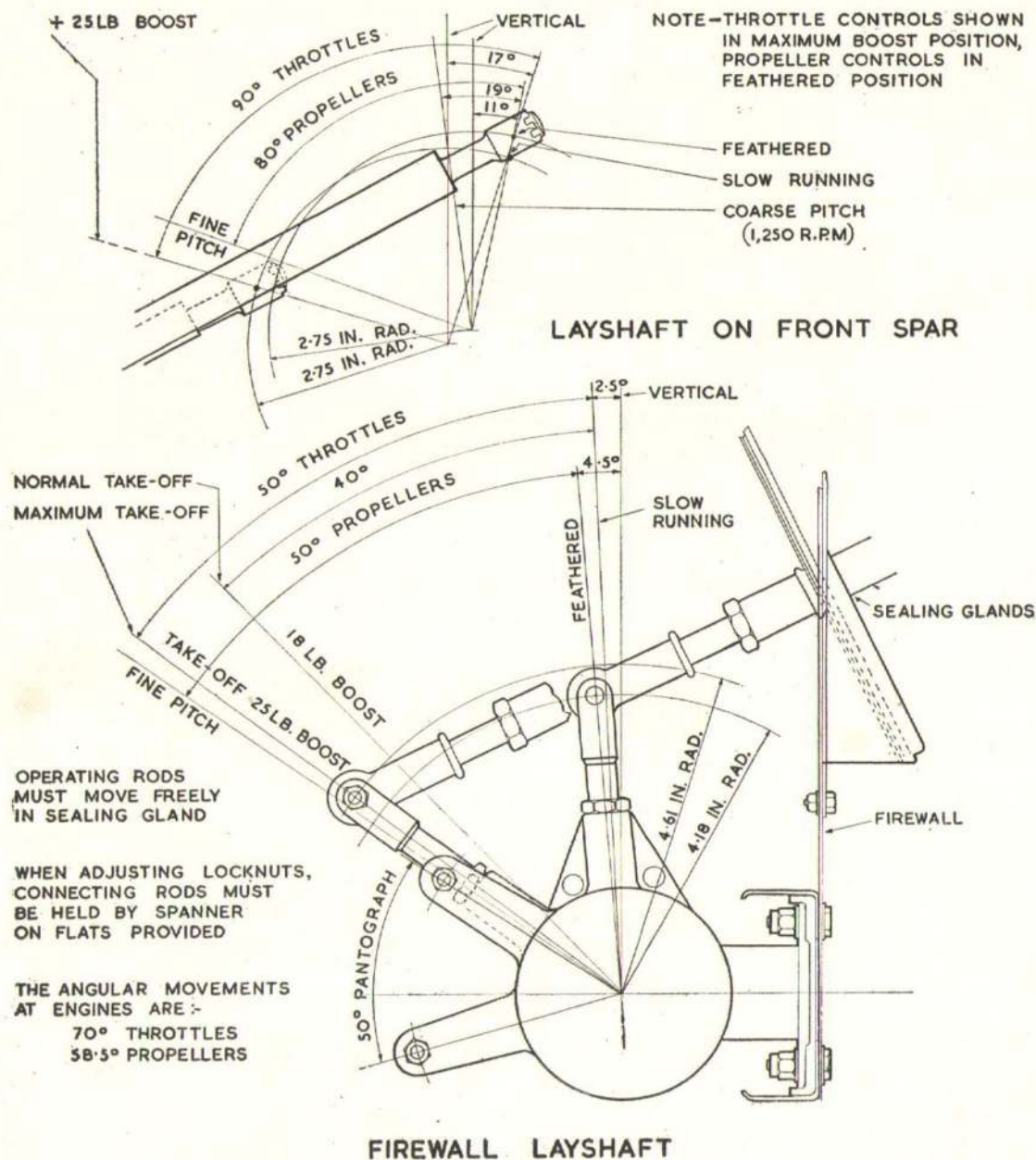

Fig. 17. Engine controls settings—outboard

REMOVAL AND ASSEMBLY

PROPELLERS

47. Instructions for removing or fitting the propellers are contained in A.P.1538K, Vol. 1. The gantry used for power plant removal is fitted with two extension arms from which a propeller may be slung during removal.

POWER PLANT GANTRY

48. Erection of the gantry is illustrated in fig. 20. The use of the gantry in conjunction with the power plant sling is shown in fig. 23.

REMOVING AND FITTING POWER PLANT

49. All four power plants are interchangeable and are removable as units after all the connections on the firewalls (fig. 21 and 22) have been disconnected. They are attached to their associated sub-frames by four self-extracting assemblies (next para.). The procedures for removing and installing a power plant are given in para. 52 and 53 respectively.

POWER PLANT ATTACHMENT ASSEMBLIES (fig. 18)

50. The power plants are attached to the four fork-ends on each sub-frame by bolts in conjunction with tapered plugs and split, internally tapered bushes. The bushes are inserted with the flange outboard (relative to the nacelle) after each power plant attachment lug and the corresponding sub-frame fork have been aligned, and the tapered plug is then inserted into the bush. The bolt is inserted into the plug with the head outboard and the cap washer and chamfered washer are fitted at the other end of the bolt. The nut is then assembled and tightened up with a standard $\frac{3}{8}$ in. B.S.F. spanner. After tightening the nut, hammer the bolt head lightly and again tighten the nut. After ensuring that each bolt is tight, coat with Protective PX-9, D.T.D.663, Stores Ref. 34B/923/924. The parts used for these assemblies are as follows :-

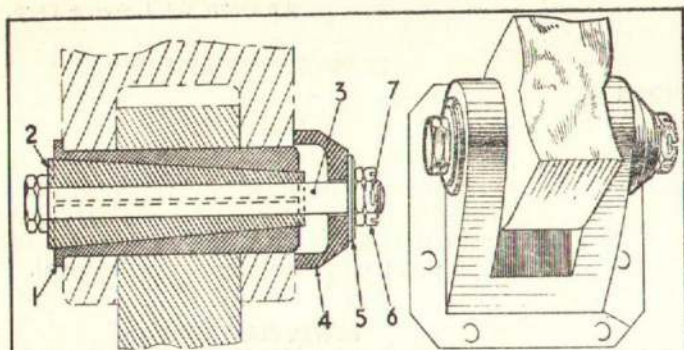

Fig. 18. Power plant attachment assembly

TABLE 3
Power plant attachment assembly components

Item	Part No.	Description	Stores Ref.
1. . .	2/O.2877	Split bush	26EA/31117
2. . .	3/O.2877	Taper plug	26EA/31119
3. . .	5/O.2877	Bolt, $\frac{3}{8}$ in. B.S.F.	26EA/31118
4. . .	4/O.2877	Cap washer	26EA/31124
5. . .	AGS.946/F	Washer	28W/6455
6. . .	A.162/J.S.	Castellated nut	28M/6463
7. . .	AGS.784/3	Split pin	28P/5032

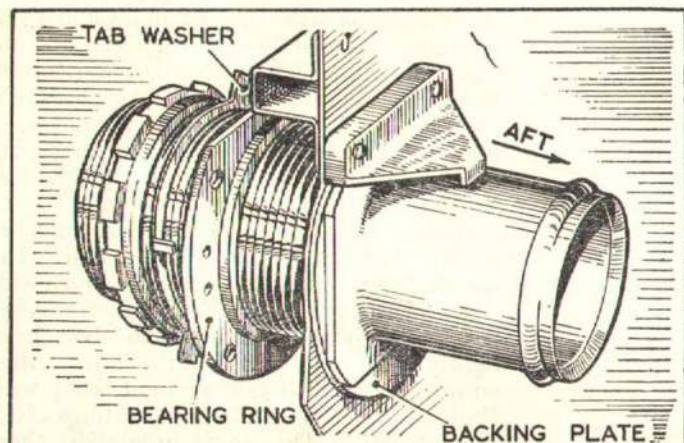

Fig. 19. Engine oil supply connection

KEY TO FIG. 20

Erecting power plant changing gantry

The gantry (Stores Ref. 26EA/32084) is for use when a crane is not available. The aircraft must be in the tail-down position when using the gantry. Cowling panels aft of the firewall must first be removed and a wooden platform (Stores Ref. 26FP/317) placed in position. All instructions on labels on gantry components, in addition to those given below, must be carefully followed.

Erection for Inboard Engine Slings

- (1) Remove two plugs from holes in engine rib top booms just forward of rear spar and screw in eye-bolts, Part No. 2/U.746 (detail B).
- (2) Through holes in top fairing panel, immediately forward of front spar, remove plugs from sockets in blocks secured to top of undercarriage beams and fit two ball sockets, Part No. 11/U.634 using bolts, Part No. 6A1/8L (detail C).
- (3) Attach rear struts, Part No. 1/U.746, to eye-bolts (detail B) and to operating screw 1/U.735 (detail A).

Note . . .
Top joint, Part No. 1/U.646 is permanently attached to operating screw.

- (4) Fit ball ends of rear side struts, Part No. 1 and 2/U.750 (outer and inner respectively) into ball sockets, raise operating screw and secure rear side struts at top joint. Screw down caps on to ball sockets.
- (5) Assemble hook, Part No. 6/U.634, link pin, Part No. 7/U.634 and reversible nuts, Part No. 8/U.634 to links, Part No. 3/U.634 and attach links to forward end of top strut, Part No. 1/U.648.

Note . . .
The recessed ends of the reversible nuts must be on the inner side.

- (6) Attach front side struts, Part No. 1 and 2/U.751 (inner and outer respectively) to forward end of top strut.
- (7) Insert ball ends of front side struts into sockets on rear side struts, and screw down caps.
- (8) Raise top strut and secure at rear top joint by quick release pin.

Propeller removal

- (5) Remove reversible nuts from pin securing hook (detail E), fit extension members, Part No. 1/U.969 (outer) and 1/U.970 (inner) to pin and refit nuts, turning recessed ends outwards. Swing both members forward and attach bracing tubes to sleeves on front side struts.

Erecting gantry for outboard engineslinging

- (10) Remove plug from block on forward face of rear spar and fit eye-bolt, Part No. 3/U.746.
- (11) Remove plugs from blocks on forward face of front spar and fit two ball sockets, Part No. 10/U.634.
- (12) Anchor rear strut, Part No. 1/U.474, at eye-bolt and fit operating screw 1/U.735 to rear strut.
- (13) Proceed as for item 4 and subsequent items for inboard engine, after ensuring that struts are correctly adjusted (refer to labels on struts).

REMOVAL SEQUENCE (fig. 21 and 22)

Note . . .

All the services to the firewall—fuel, oil and water/methanol systems—must be drained before removal.

INBOARD ENGINE FIREWALLS ONLY

Disconnect the two pipes from the top of the oil-and-water trap aft of the firewall at the lower starboard corner of the sub-frame.

Disconnect the upper union on the pneumatic system pressure regulator valve on the aft face of the firewall (above the air-intake fire extinguisher connection).

Remove the four bolts securing the water/methanol system regulator valve to the aft face of the firewall. Disconnect the drain pipe union on the starboard side of the valve.

Disconnect all necessary priming system pipes from the pump and T-union at the aft face of the firewall and unclip any pipes as necessary.

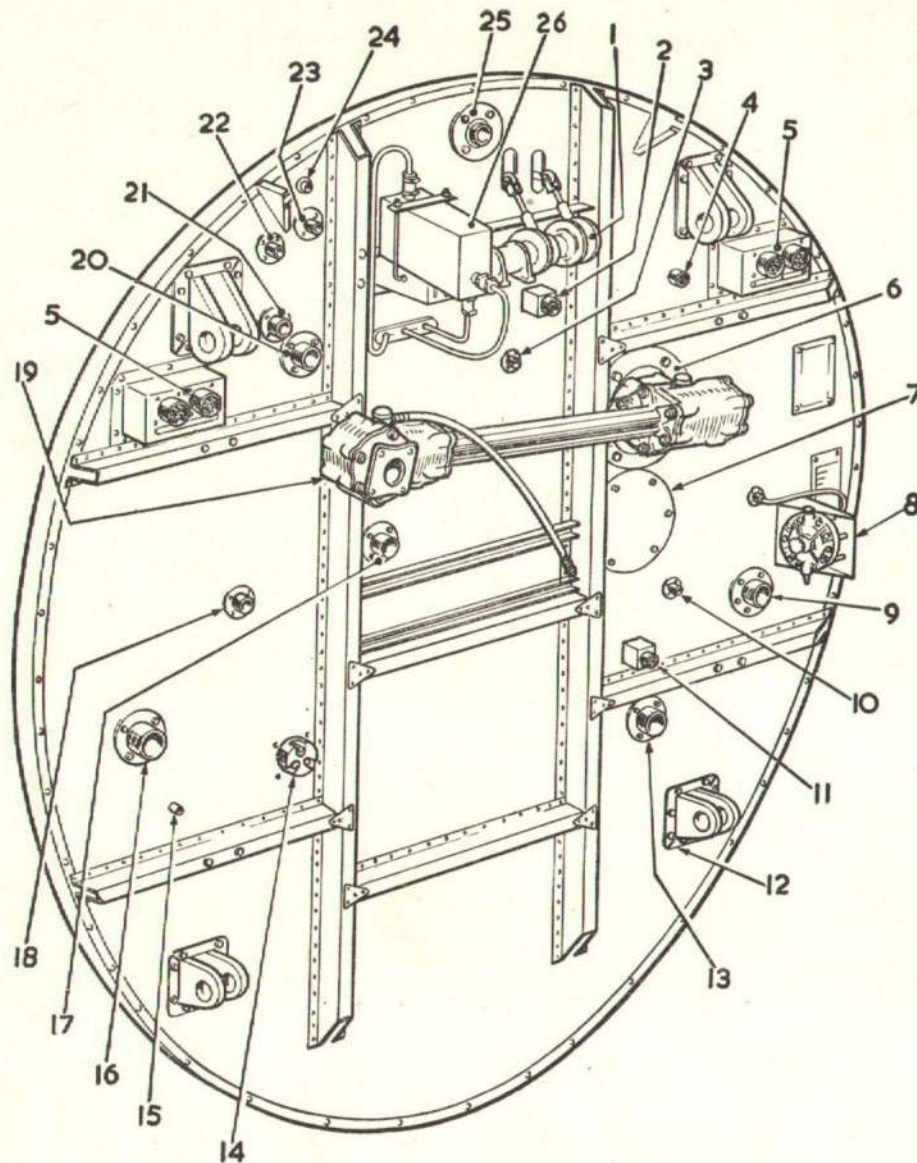

INBOARD

Fig. 21. Firewall details—I

KEY TO FIG. 21 AND 22

- 1 ENGINE CONTROLS COUNTERSHAFT
- 2 IGNITION PLUG CONNECTION
- 3 OIL FEED TO GEARBOX DRIVE
- 4 FLAME SWITCH LEAD PLUG
- 5 MISCELLANEOUS ELECTRICAL SERVICES PLUGS
- 6 GEARBOX DRIVE SEALING PLATES
- 7 ACCESS PANEL TO FORWARD FACE OF GEARBOX
- 8 OIL PRESSURE TRANSMITTER
- 9 FUEL SUPPLY PIPE AND FILTER CONNECTION
- 10 AUXILIARIES OIL DRAINS CONNECTION
- 11 ELECTRICAL PLUG FOR FLOWMETER CONNECTION
- 12 FIREPROOF SEALS ON POWER PLANT MOUNTING FORKS
- 13 OIL SUPPLY CONNECTION
- 14 ENGINE STARTER CONNECTION
- 15 PNEUMATIC SERVICES CONNECTION
- 16 OIL RETURN CONNECTION
- 17 WATER/METHANOL CONNECTION
- 18 AIR INTAKE EXTINGUISHER CONNECTION
- 19 GEARBOX DRIVE
- 20 OIL VENT CONNECTION
- 21 PROPELLER FEATHERING CONNECTION
- 22 PROPELLER DE-ICING CONNECTION
- 23 BOOST CONNECTION
- 24 PRIMING CONNECTION
- 25 FIRE EXTINGUISHER SPRAY CONNECTION
- 26 OIL AND WATER TRAP (VACUUM SYSTEM)

RESTRICTED

Remove the four bolts securing the fuel distributor tank to the firewall. Disconnect the valve rails.

INBOARD AND OUTBOARD FIREWALLS

Remove the sealing plates from the firewall at the drive connection to the gearbox and disconnect the drive from the gearbox.

Remove the fireproof seals at the power plant attachment forks.

Disconnect all pipes aft of the firewall at the adapters or from items of equipment which would be better left secured to the firewall after its removal.

Disconnect all electrical leads aft of the firewall as appropriate.

Uncouple the engine controls at the countershaft. Remove the end-fittings from the control rods to permit them to be withdrawn from the sealing glands.

Remove the three bolts securing the fuel filter mounting bracket.

Remove the bolts from the clips securing the firewall to the sub-frame.

NOTE...

After removing the firewall, all equipment left supported only by pipes or electrical leads should be removed. Items attached to the aft face of the firewall, which do not interfere with its removal, may be disconnected afterwards.

51. These assemblies are removed by first extracting the split-pin, removing the nut, common washer and cap washer and inserting the bolt the other way round. Then fit the cap washer, common washer, and nut and tighten the latter. Tap the bolt head lightly to loosen the taper plug, and repeat if necessary. When the taper plug is loose, remove the nut, washers and bolt, and remove the taper plug and split bush.

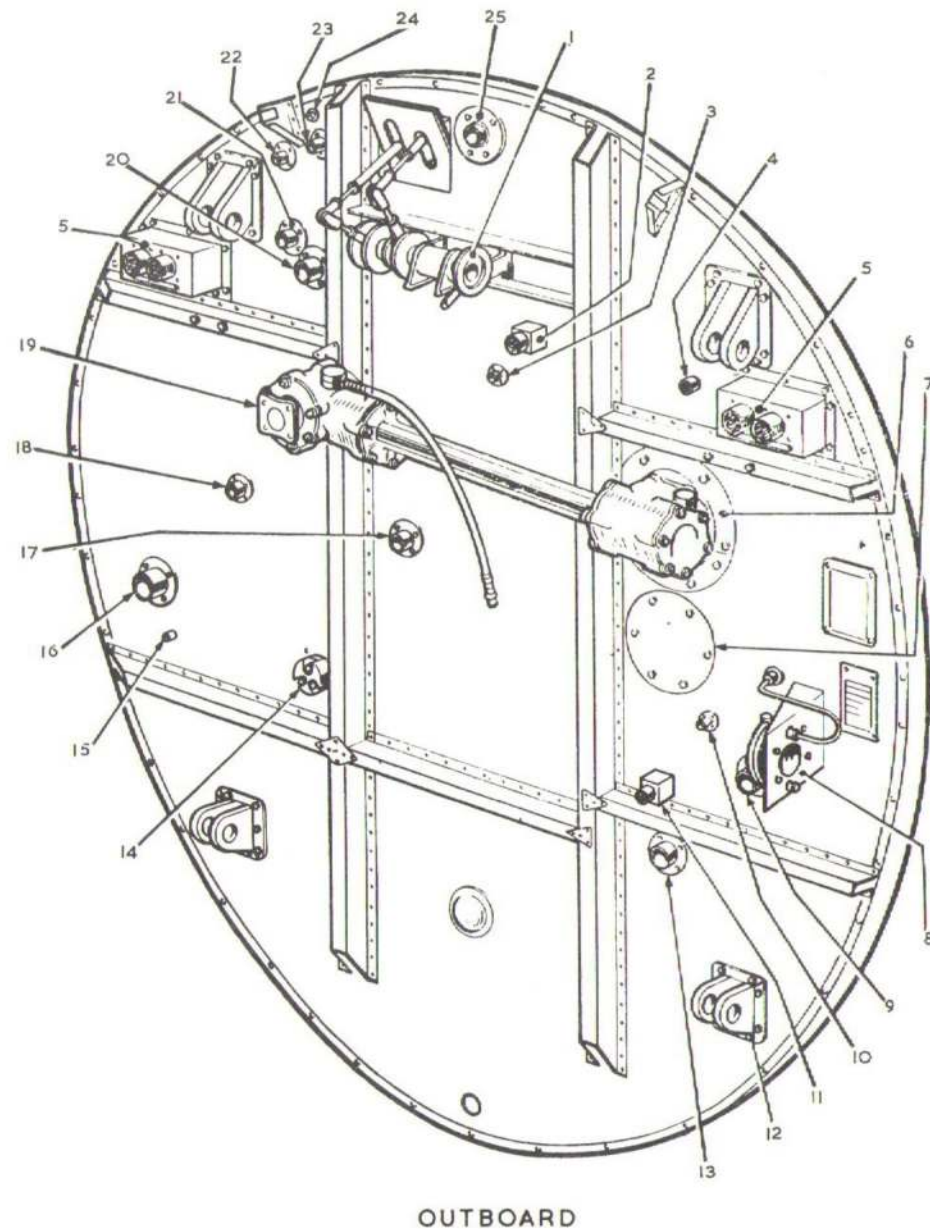

Fig.22. Firewall details - 2

RESTRICTED

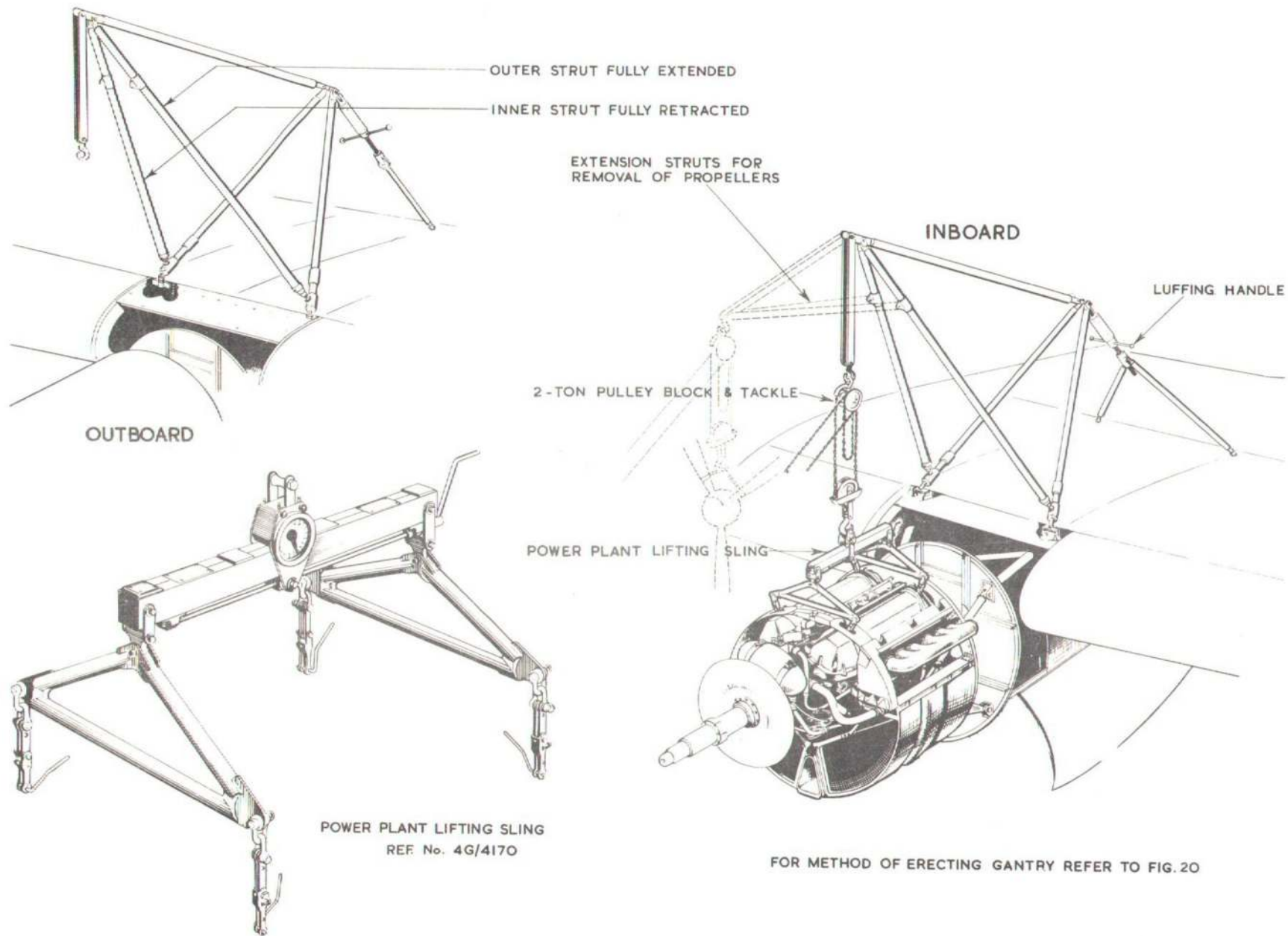

Fig. 23. Power plant slinging
RESTRICTED

REMOVAL OF POWER PLANT (fig.18 to 23)

52.

- (1) Erect the gantry complete (fig.20) or use a suitable crane.
- (2) Remove the propeller (A.P.1538K, Vol.1 and fig.23).
- (3) Remove the rear ring of cowling from the power plant, and the cowling panels aft of the firewall.
- (4) Remove the oil drains tank (A.P.4275A, Vol.1).
- (5) Uncouple the drive from the engine to the gearbox cross drive.
- (6) Disconnect all pipes at the firewall (fig.19, 21 and 22).

NOTE...

Remove the oil feed pipe rubber union behind the firewall and prepare the firewall connector by disengaging the tabs of the tab washer from the slotted nut forward of the firewall and slackening the nut to ease the removal of the engine pipe female coupling.

- (7) Uncouple the engine controls at the firewall layshaft.
- (8) Disconnect all electrical plugs and the starter leads (fig.21 and 22).
- (9) Take the weight of the power plant, using the engine sling with the gantry, or a suitable crane (fig.23).
- (10) Remove the power plant upper attachment assemblies (fig.18).
- (11) Remove the power plant lower attachment assemblies (fig.18).
- (12) Swing the power plant away, and lower it on to the power plant stand.

KEY TO FIG.24

1. DRAIN ALL OIL FROM THE GEARBOX.
2. REMOVE THE COVER FROM THE TOP OF THE GENERATOR; LOOSEN THE TERMINAL SCREWS.
3. WITHDRAW THE ELECTRICAL SOCKET.
4. DETACH THE COOLING PIPE FROM THE GENERATOR.
5. UNSCREW THE GENERATOR RETAINING NUTS, AND REMOVE THE GENERATOR.
6. FIT A BLANKING COVER OVER THE GENERATOR DRIVE.
7. DISCONNECT ALL PIPES AND ELECTRICAL LEADS FROM THE GEARBOX.
- 8.* REMOVE THE BOLTS ATTACHING THE GEARBOX DRIVE TO THE CASING.
- 9.* SUPPORT THE GEARBOX, AND UNSCREW THE BOLTS FROM THE MOUNTINGS.
10. WITHDRAW THE GEARBOX FROM THE SPLINED SHAFT AND LIFT OUT.

*ALSO SHOWN ON FIG.25.

VIEW SHOWING MOUNTING OF PORT
INBOARD AUXILIARY GEARBOXVIEW OF STARBOARD INBOARD
ACCESSORIES GEARBOX

Fig.24. No.2 and 3 accessories gearboxes.

RESTRICTED

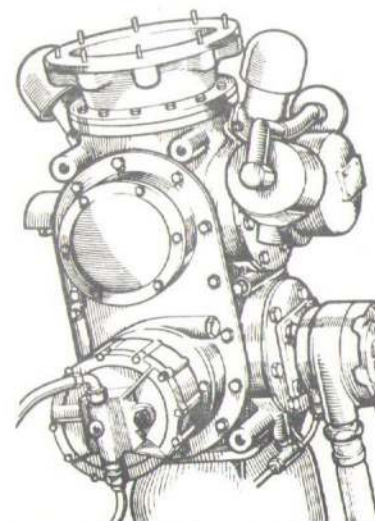
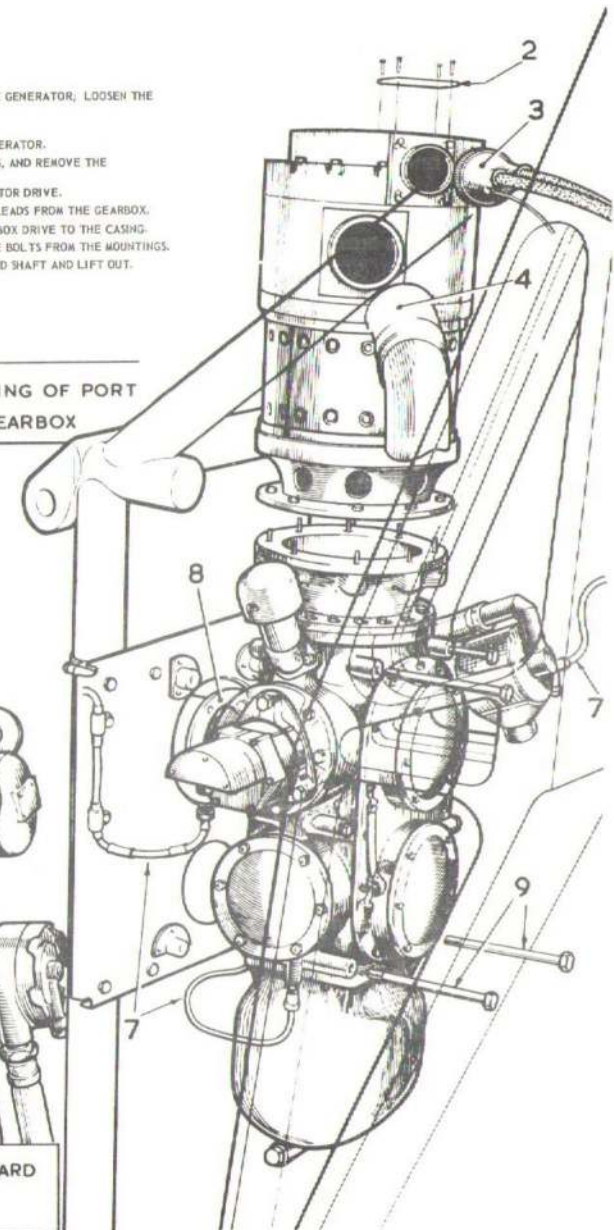
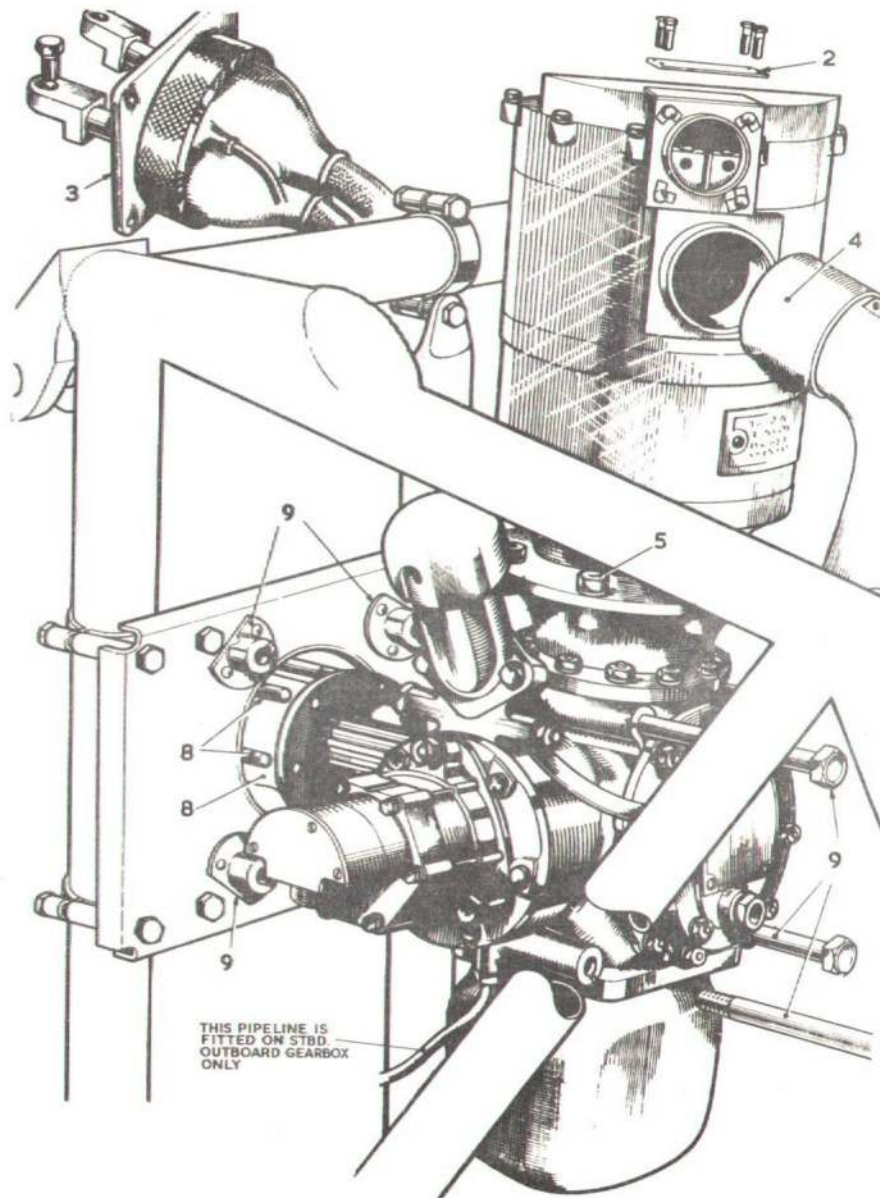

Fig.25. No.1 and 4 accessories gearboxes.

INSTALLATION OF POWER PLANT

53. This operation is a reversal of the procedure for removal, but, owing to the possibility of difficulty being experienced in connecting the three engine oil connections at the firewall after the power plant has been attached to its associated sub-frame, the following sequence of operations should be followed:-

- (1) The oil supply connection is illustrated in fig.19 and should be prepared by ensuring that a new tab washer (Ref.No.26FP/2684) is fitted and that the nut is slacked towards the forward end of the connector, well clear of the bearing ring.

KEY TO FIG.25

1. Drain all oil from gearbox.
2. Remove the cover from the top of the generator; loosen the terminal screws.
3. Withdraw the electrical socket.
4. Detach the cooling pipe from the generator.
5. Unscrew the generator retaining nuts and remove the generator.
6. Fit a blanking cover over the generator drive.
7. Disconnect all pipes and electrical leads from the gearbox.
8. Remove the bolts attaching the gearbox drive to the casing.
9. Support the gearbox and unscrew the bolts from the mountings.
10. Withdraw the gearbox from the splined shaft and lift out.

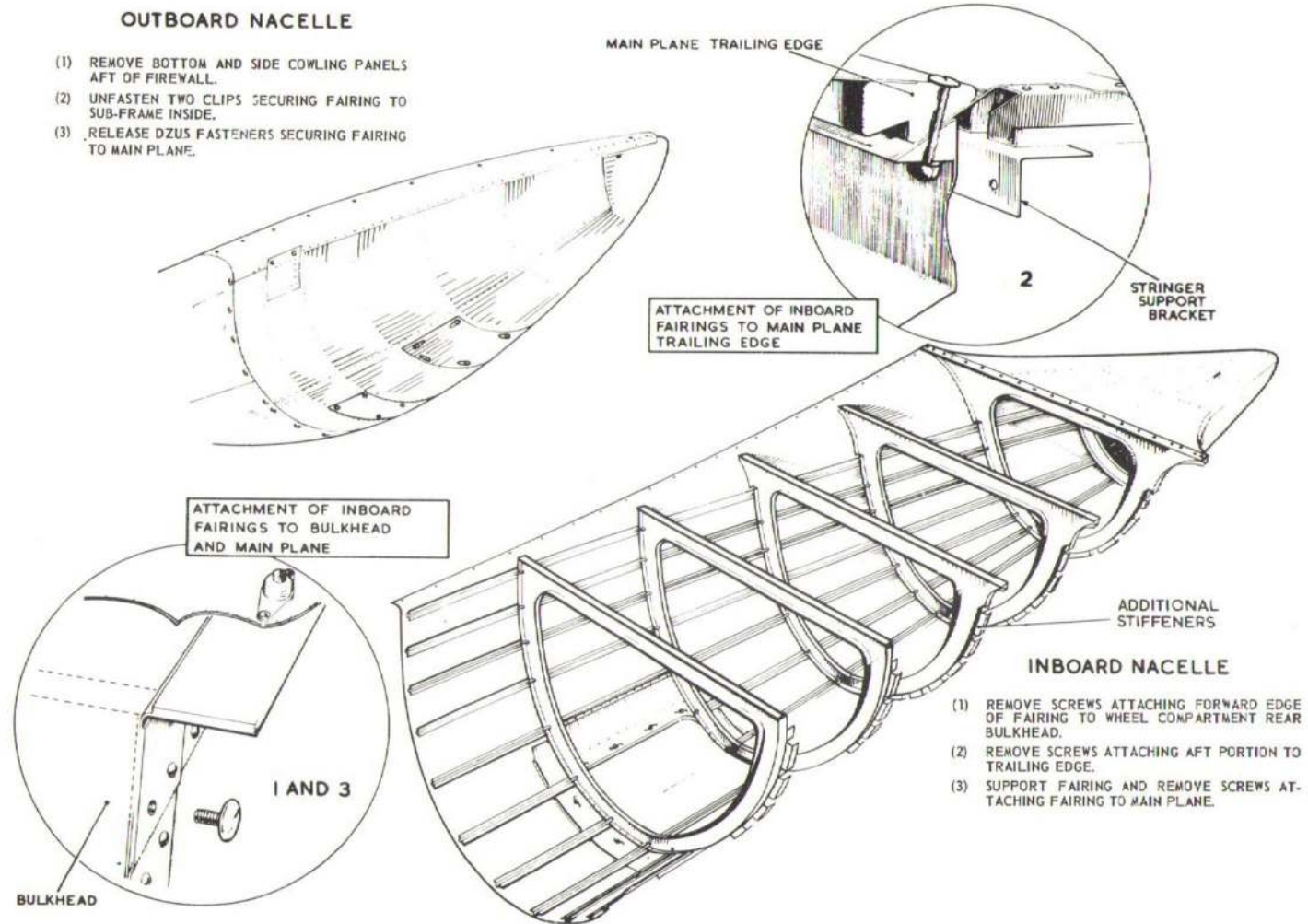
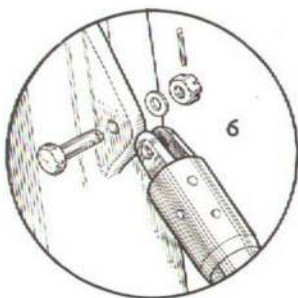
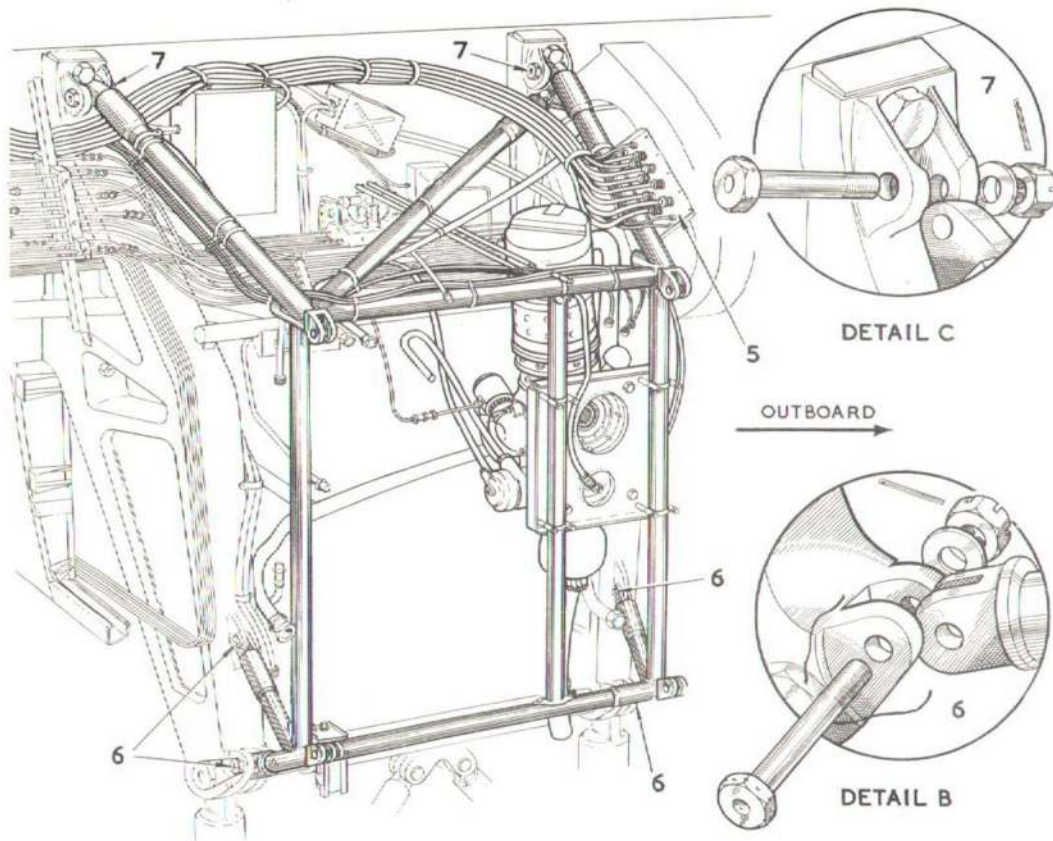

Fig. 26. Rear nacelle fairings

RESTRICTED



DETAIL A

REMOVAL SEQUENCE

1. REMOVE POWER PLANT (fig.18 to 23)
2. REMOVE FIREWALL (fig.21 and 22)
3. REMOVE AUXILIARIES GEARBOX (fig.24 or 25)
4. UNCLIP FROM SUB-FRAME ALL PIPED SERVICES AND ELECTRICAL LEADS
- (5) DISCONNECT ELECTRICAL SERVICES AT NOSE RIB
- (6) SUPPORT SUB-FRAME AND REMOVE BOLTS SECURING THE LOWER STRUTS TO THE UNDERCARRIAGE BEAMS
- (7) REMOVE BOLTS SECURING THE UPPER STRUTS TO THE UNDERCARRIAGE BEAMS AND LOWER THE SUB-FRAME FROM AIRCRAFT

- (2) Slide the connection aft to its fullest extent before offering up the power plant.
- (3) Whilst offering up the power plant, start the female halves of the connectors (on the pipes to the engine) on the threads of the fire-wall connections and screw them on as far as possible by hand.
- (4) Locate the bearing ring and tab washer against the forward face of the bulkhead, tighten the slotted nut and lock it with the tabs on the tab washers.
- (5) Insert the split bushes of the power plant attachment assemblies (fig. 18), each with its bearing flange outboard (relative to the nacelle concerned) into the correctly aligned attachment lugs and forks and assemble the remaining parts as described in para.50.
- (6) Tighten the female halves of all three oil connections.
- (7) Make all remaining connections (fig.21 and 22).

NACELLE STRUCTURES AND ACCESSORIES

54. Instructions are given in fig.24 to 28 for removal of the components constituting the inboard and outboard nacelles, and the accessories gearboxes.

Fig.27. Removal of inboard sub-frame

RESTRICTED

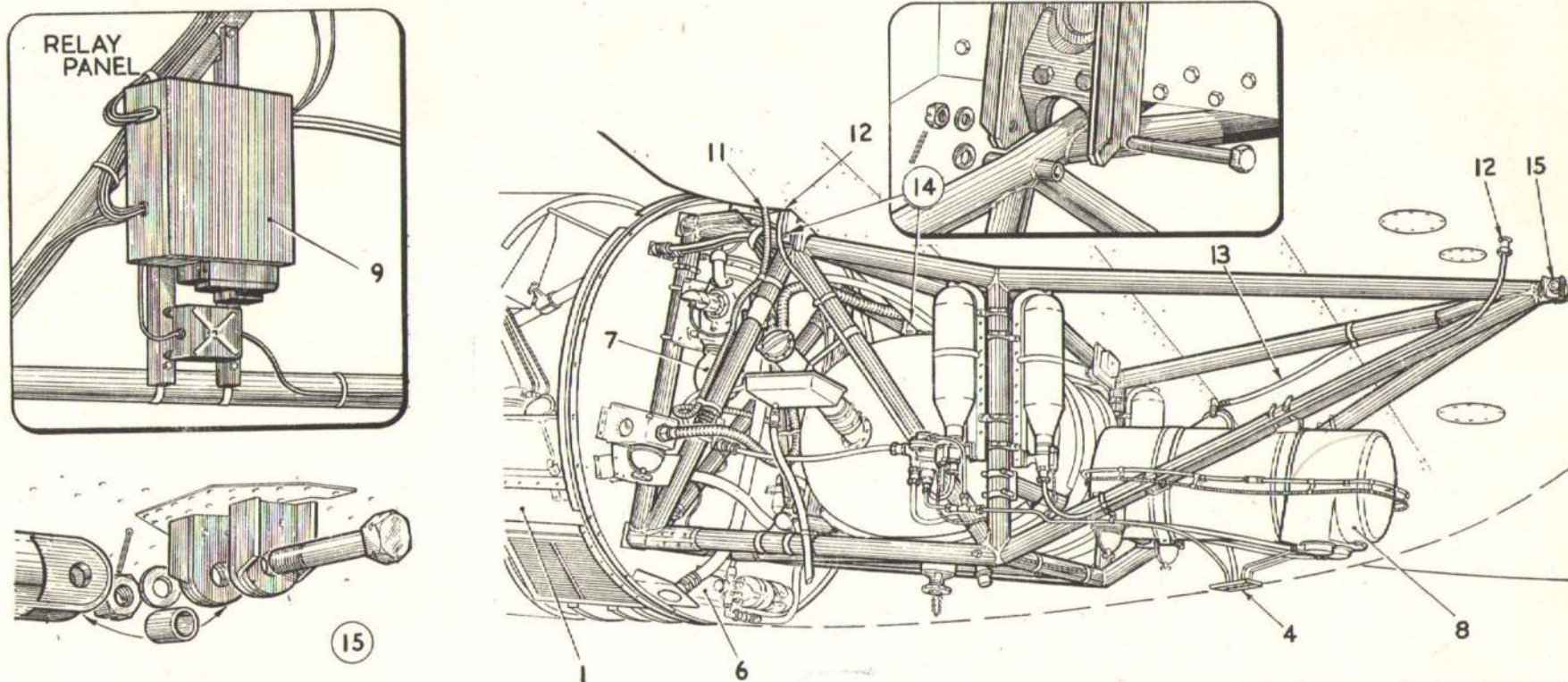

KEY TO FIG. 28

- (1) Remove the power plant
- (2) Remove the inboard and outboard side panels and bottom panel
- (3) Disconnect the nacelle fairing attachment clips
- (4) Disconnect the water/methanol system drain pipes through the access doors
- (5) Remove the rear nacelle fairing
- (6) Remove the firewall (fig. 17)
- (7) Remove the auxiliaries gearbox (fig. 19)
- (8) Remove the water/methanol tank (Refer to Sect. 4, Chap. 2)
- (9) Disconnect all electrical services, unclip from the sub-frame, and tie to the front spar
- (10) Disconnect all piped services at the nose ribs and unclip from the sub-frame where necessary
- (11) Unclip the fuel vent pipe from the sub-frame
- (12) Disconnect the fire-extinguisher pipes to the tank bay
- (13) Release the water/methanol vent pipe from the sub-frame
- (14) Support the sub-frame and remove the two attachment bolts
- (15) Remove the rear attachment bolt and lower the sub-frame from the aircraft

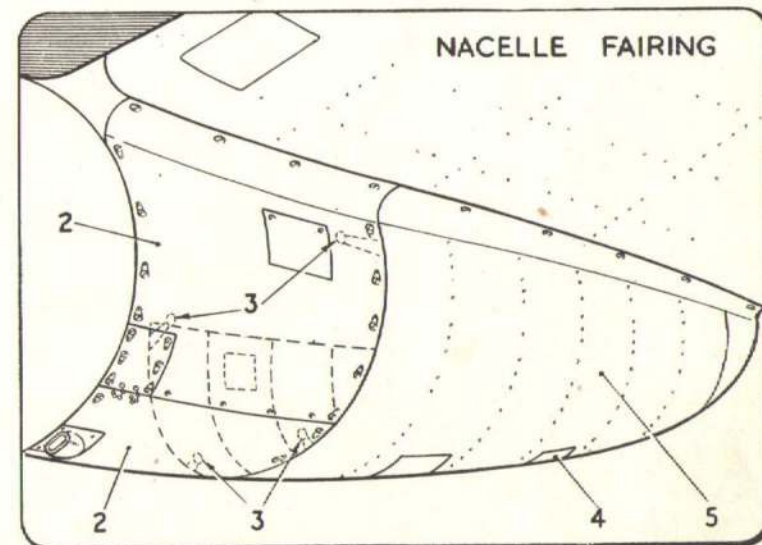

Fig. 28. Removal of outboard sub-frame



This file was downloaded
from the RTFM Library.

Link: www.scottbouch.com/rtfm

Please see site for usage terms,
and more aircraft documents.

