

Chapter 3.—OIL SYSTEM

LIST OF CONTENTS

	Para.
Introduction	1
Oil tanks	2
Internal construction	3
Crash proof covering	4
Oil filters	5
Oil circuit	8
Feathering circuits	9
Oil temperature and pressure gauges	10
Oil dilution system	11
SERVICING	
Oil tanks	
Draining	12
Cleaning	13
Oil filters	
Cleaning	14
Oil pressure transmitters	15
Removal and assembly	
Oil tanks	16

LIST OF ILLUSTRATIONS

	Fig.
Oil tank—inboard	1
Oil tank—outboard	2
Tank oil movement	3
Oil filter unit	4
Oil system—inboard	5
Oil system—outboard	6
Typical oil pipe connections	7
Section of vent valve	8
Removal of inboard oil tank	9
Removal of outboard oil tank	10

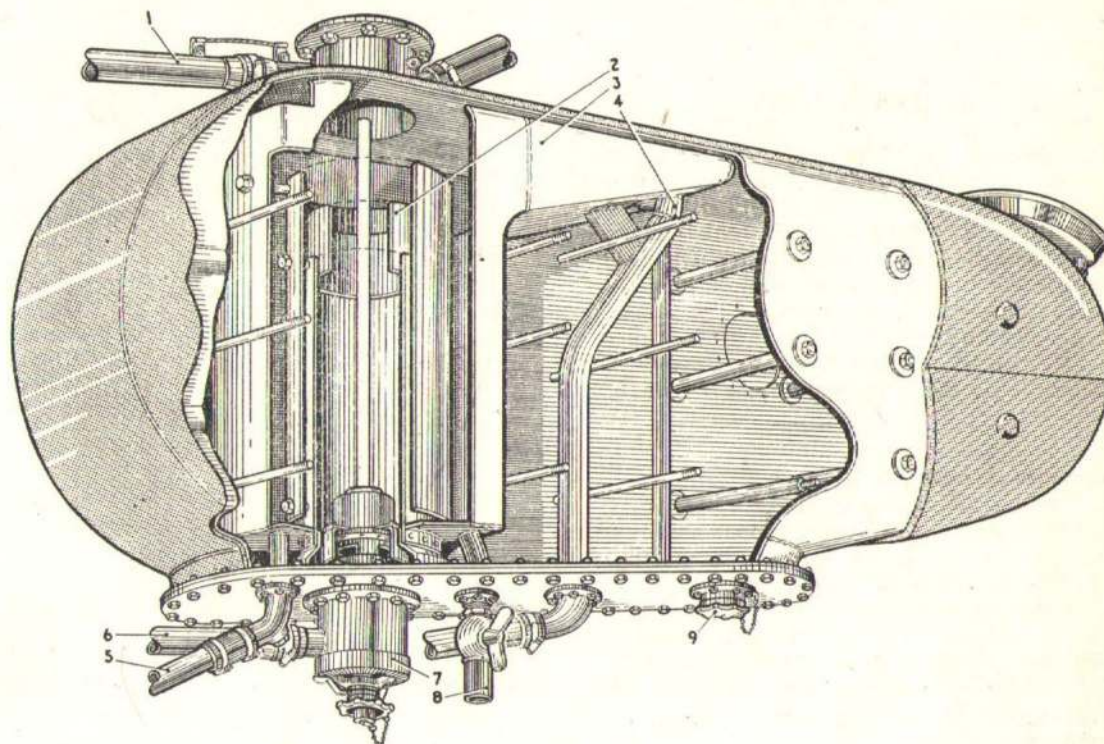

Fig. 1. Oil tank—inboard

- | | |
|-------------------------|------------------------------|
| 1 VENT PIPE FROM ENGINE | 5 FEATHERING OIL PIPE |
| 2 UPPER BAFFLE | 6 MAIN OIL FEED PIPE |
| 3 DE-AERATING RAMP | 7 OIL FILTER |
| 4 OIL RETURN PIPE | 8 FEATHERING WELL DRAIN COCK |
| 9 MAIN OIL DRAIN VALVE | |

INTRODUCTION

1. Each of the four power plants has an independent oil system with its own tank. The inboard tanks are mounted chordwise at the wing breaks between the centre and intermediate main plane sections. The outboard tanks are secured by steel straps in the engine sub-frames. All oil pipes are of copper with flexible couplings and the firewall connections are supported by bolts and split retaining flanges.

OIL TANKS (fig. 1 and 2)

2. The tanks are of light-alloy construction and are installed by reversing the removal instructions given on fig. 9 and 10. The inboard tanks, which are long and narrow, are braced internally between the flat sides by distance tubes and long bolts, and have a filler positioned aft near the top of the curved face. The outboard tanks each have a filler on the outboard side (refer to Section 2, Chapter 4 for the location of the access panels).

Internal construction (fig. 1, 2 and 3)

3. Inside each tank is a de-aerating ramp. Oil from the engine return pipe flows over the surface of this ramp into a partial-circulation chamber whence it enters a filter located at the bottom of the chamber. Each of the four tanks has an oil capacity of 26 gallons of which $2\frac{1}{2}$ to $2\frac{3}{4}$ gallons are held in the outer partial-circulation chamber, or feathering well, as a reserve for propeller feathering.

Note . . .

The construction of the bottom portion of the partial-circulation chamber in the inboard tanks is similar to that of the outboard tanks.

Crash proof covering

4. This is to Spec. D.T.D. 1072. Where the covering is cut away for fittings, the edges are clamped by flange rings which fit on studs provided for attaching the fittings.

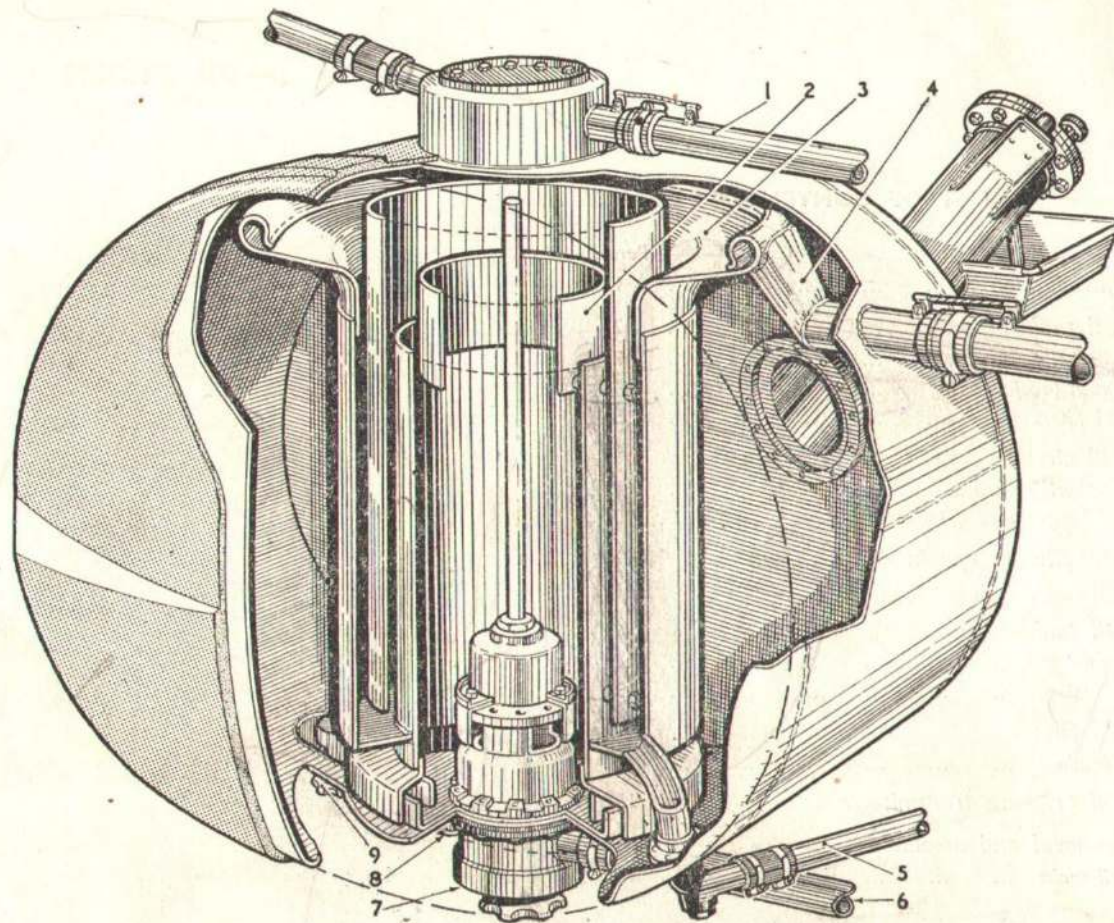

Fig. 2. Oil tank—outboard

- 1 VENT PIPE FROM ENGINE
- 2 UPPER Baffle
- 3 DE-AERATING RAMP
- 4 OIL RETURN PIPE

- 5 FEATHERING OIL PIPE
- 6 MAIN OIL FEED PIPE
- 7 OIL FILTER
- 8 FEATHERING WELL DRAIN COCK

- 9 MAIN OIL DRAIN VALVE

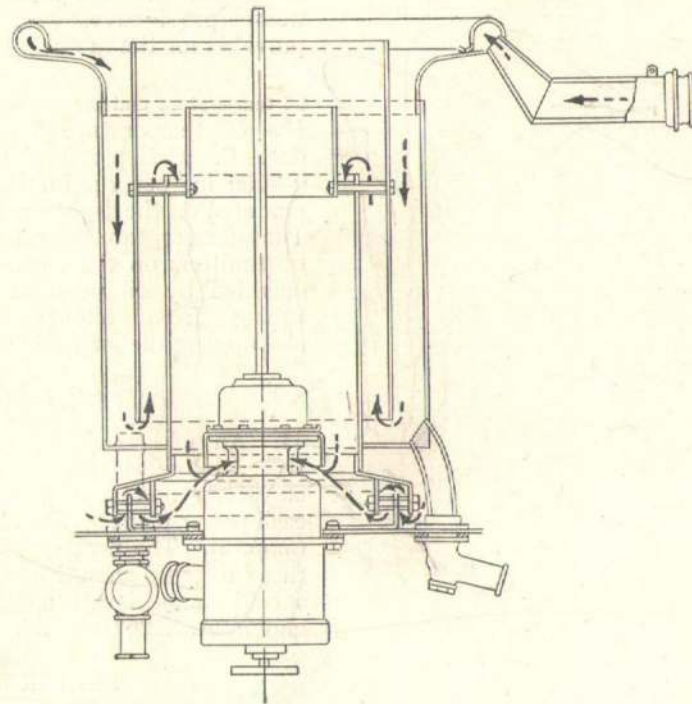

Fig. 3. Tank oil movement

Oil filters (fig. 4)

5. The construction is shown in the illustration. The attaching flange is bolted to the opening at the bottom of each tank by twelve bolts. Oil enters the filter through two ports in the upper section inside the tank, passes through the filter element, and out through the union at the bottom of the filter. A piston valve is pressed down by a spring when the filter element is removed and seals the two entry ports to prevent escape of oil from the tank. A vertical vent pipe from the top of the filter communicates with the vent chamber at the top of the tank.

6. Prior to Mod. 471 the filter has two corrugated meshes, the inner being of coarser mesh than the outer. Mod. 471 introduces a

single mesh filter element. The element base plate, with its rubber sealing ring, seals the lower open end of the body when the filter is in position. The element is held in position by an assembly made up of a sealing washer, a nut having two arms, an internally threaded collar and the hand screw and its double-threaded shaft.

7. When inserting the element, the ends of the arms on the nut slide through two cut-outs into an annular groove, inside the bottom opening of the body, and are turned through 90 deg. to lock the filter. The screwed collar, which is knurled, is then turned, forcing the base plate sealing ring on to its seating. The hand screw is now turned causing its shaft to move upward due to its double thread,

This forces the piston valve up and opens the inlet ports to the filter. A ratchet-type locking device and locking wire attachments on the arms of the nut, complete the assembly.

OIL CIRCUIT (fig. 5 and 6)

8. Oil passes through the filter from the partial circulation chamber and by copper piping, which incorporates an electrically-operated oil cock, to the engine oil pump. The four oil cocks are not provided with any means of control, at present, and are set in the open position. Future modification action is intended to link these cocks to the appropriate manual and automatic control circuits. The return flow is piped first to the cooler at the front of the power plant and thence to the inlet connection on the tank. This communicates with a stack pipe which conveys the oil to the oil spreader at the top of the de-aerating ramp from which the oil flows to the outermost feathering well compartment or partial circulation chamber. Oil from the bottom of this passes up the intermediate space and down into the inner part where it passes out of the filter. As the engine uses oil, the level in this inner chamber falls and additional oil flows in from the main bulk outside the outer casing through the baffle system at the bottom of the tank (fig. 3). From the union on the firewall, which is connected to the vent pipe from the engine, a pipe is led aft to a vent chamber at the top of the associated oil tank. This chamber communicates with atmosphere through a vent valve (fig. 8) connected to a short pipe from the vent chamber. The vent valve is set to blow off at $3\frac{1}{2}$ lb. per sq. in. and admit air into the oil tank should the internal pressure fall below $\frac{1}{2}$ lb. per sq. in.

Feathering circuits (fig. 5 and 6)

9. Oil is taken from the base of each feathering oil well through a separate union and copper piping to the inlet side of the feathering pump mounted on the aft face of the firewall. The pumps are electrically-driven and are controlled by the feathering push-buttons on the pilot's panel. A pressure

(A.L. 71, Aug. 1954)

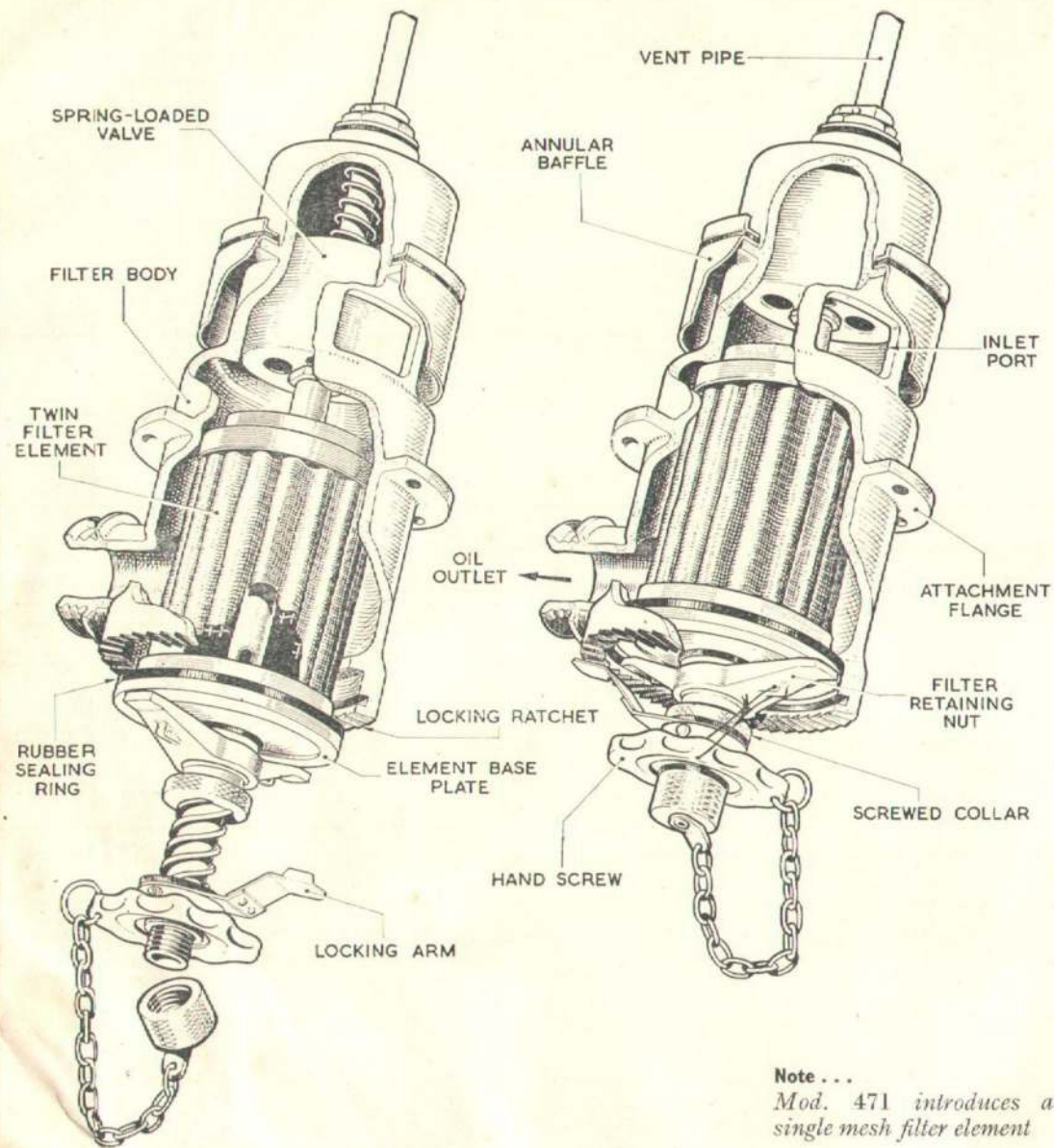

Fig. 4. Oil filter unit

Note . . .
Mod. 471 introduces a
single mesh filter element

cut-out switch, mounted on a T-union in the delivery line from the pump, automatically switches off the pump motor when feathering or unfeathering is completed. A fabric weatherproof cover with a zip fastener is provided for the motor.

Oil temperature and pressure gauges

10. Oil temperature gauges reading 0–120 deg. C. and pressure indicators reading 0–150 lb. per sq. in. for each engine are mounted on the flight engineer's main panel. The former are electrically-operated by transmitters on the engines; the latter are operated by oil pressure through capillary tubing from oil pressure transmitters mounted on the forward faces of the firewall.

OIL DILUTION SYSTEM

11. An electrically-operated valve, controlled by one of four switches on the flight engineer's auxiliary panel, is provided in each power plant (A.P.4275A, Vol. 1, Sect. 3, Chap. 2). The necessary time during which these switches should be ON whilst starting a cold engine is given in Sect. 2, Chap. 2, and in A.P.4267B—P.N.

SERVICING

OIL TANKS

Draining

12. The main drain valves (Stores Ref. 28Y/11844) on the oil tanks are self-sealing (fig. 5). After the knurled cap has been removed the oil is retained in the tank by a spring-loaded valve, which must be raised before the oil will drain out. A hose adapter type A.S.2580 (Stores Ref. 4K/2479 and 4K/2480), which incorporates a device for lifting the valve as it is screwed on, should be used with a suitable length of 2 in. bore hose to direct the oil into a receptacle of at least 27 gall. capacity. The feathering well cock has a hose spigot and a butterfly-type operating handle. Whilst a tank is draining, the filler cap should be removed.

Cleaning

13. Refer to A.P.4117A, Vol. 1, Sect. 4, for the method of cleaning oil tanks.

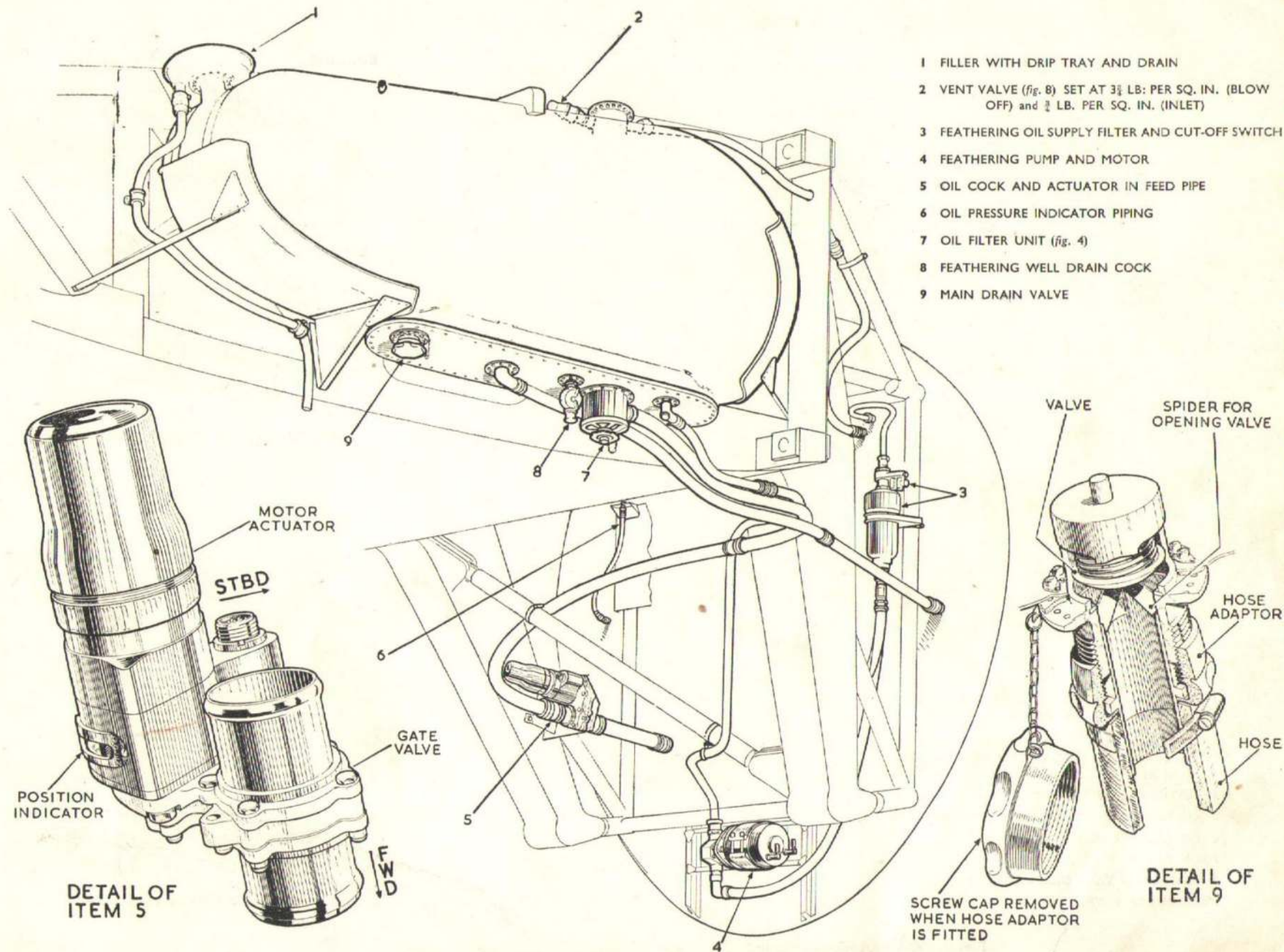
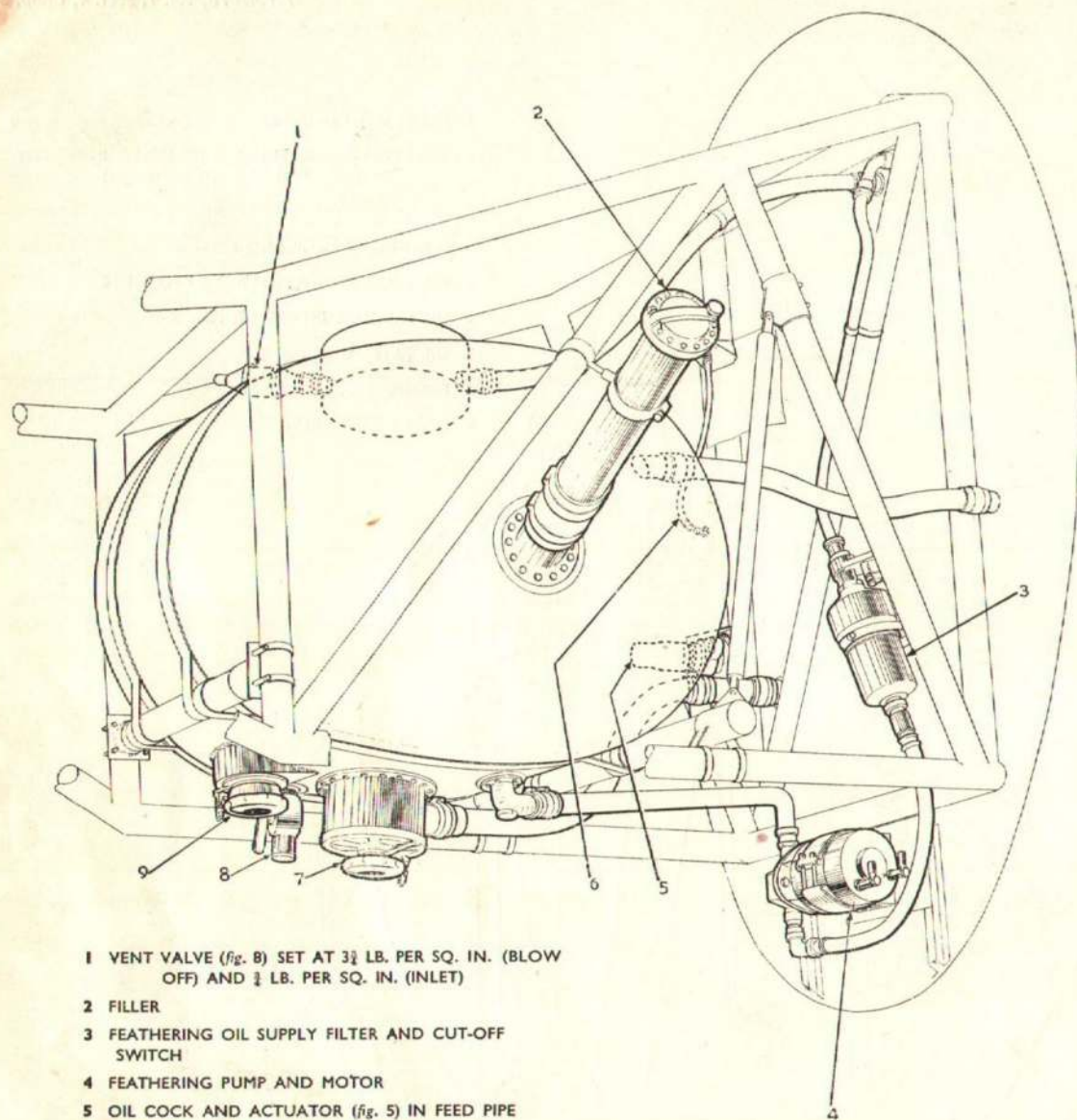

Fig. 5. Oil system—inboard

RESTRICTED



- 1 VENT VALVE (fig. 8) SET AT $3\frac{1}{2}$ LB. PER SQ. IN. (BLOW OFF) AND $\frac{1}{2}$ LB. PER SQ. IN. (INLET)
- 2 FILLER
- 3 FEATHERING OIL SUPPLY FILTER AND CUT-OFF SWITCH
- 4 FEATHERING PUMP AND MOTOR
- 5 OIL COCK AND ACTUATOR (fig. 5) IN FEED PIPE
- 6 OIL PRESSURE INDICATOR PIPING
- 7 OIL FILTER UNIT (fig. 4)
- 8 FEATHERING WELL DRAIN COCK
- 9 MAIN DRAIN VALVE (fig. 5)

Fig. 6. Oil system—outboard

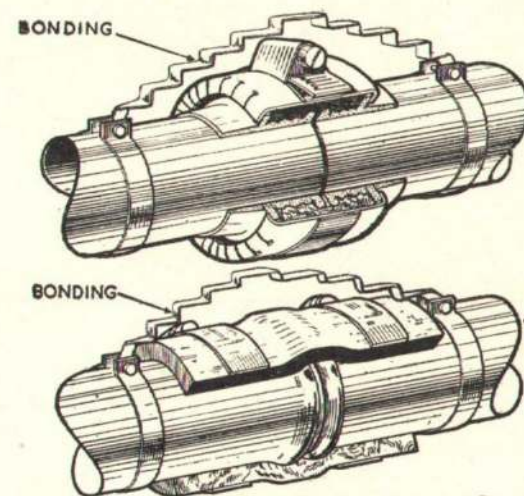

Fig. 7. Typical oil pipe connections

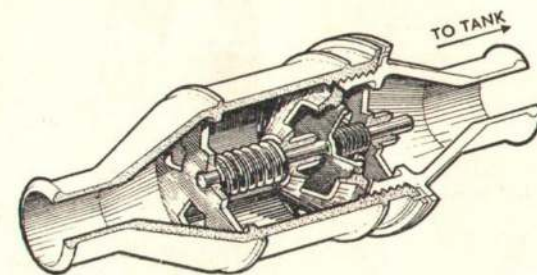

Fig. 8. Section of vent valve

OIL FILTERS

Cleaning (fig. 4)

14. A filter is located at the base of each tank.

- (1) Remove the locking-wire and unscrew the hand screw to its fullest extent. This closes the inlet ports from the tank.
- (2) Remove the knurled cap at the end of the screwed rod (this is retained by a slave chain) and allow the filter to drain.
- (3) Slacken the collar at the top end of the screwed rod.
- (4) Turn the filter-retaining nut through 90 deg., until the arm ends can be withdrawn from the slots in the casing. Remove the filter element.
- (5) Clean the inside of the filter and the element with flushing oil, Stores Ref. 34D/68 and finally with filtered, unleaded gasoline.

OIL PRESSURE TRANSMITTERS

15. Information on the servicing, removal and installation of these transmitters, which are mounted on the forward faces of the firewalls is given in A.P.1275A, Vol. 1, Sect. 3, Chap. 9.

REMOVAL AND ASSEMBLY

Note . . .

On illustrations of removal procedures, key numbers which are not bracketed refer to operations not shown on the relevant illustration.

Oil tanks

16. Removal of the oil tanks is shown in fig. 9 and 10.

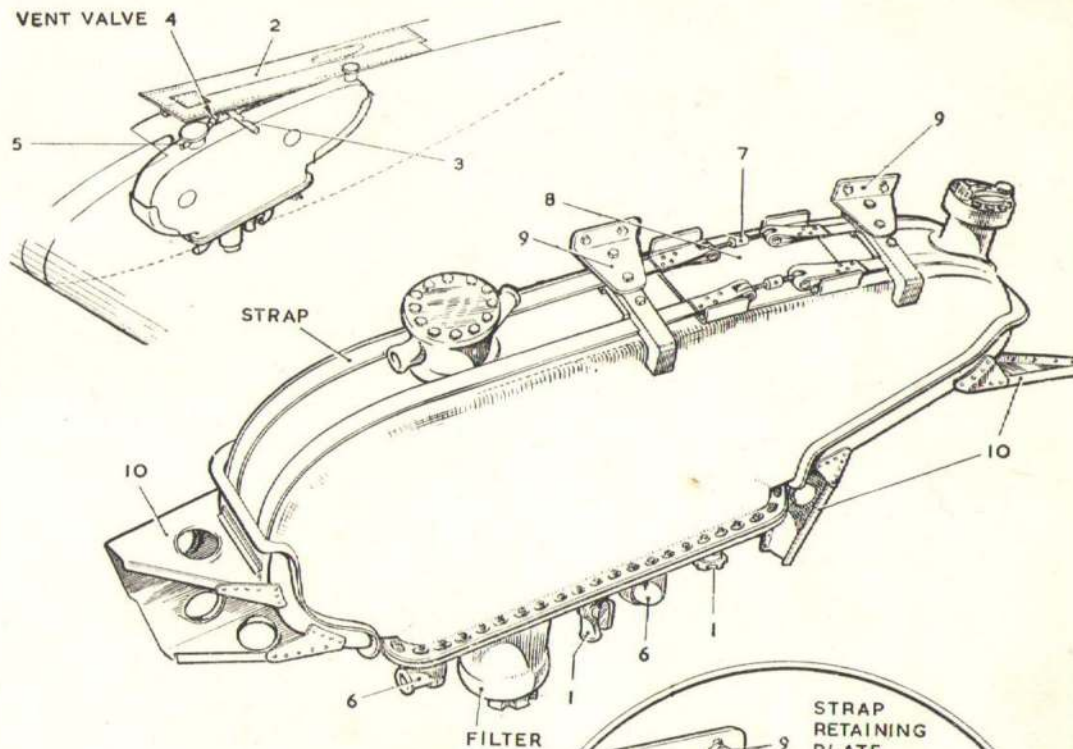

- (1) Drain the tank using hose and adapter (refer to text, para. 12) on the main drain cock.
- (2) Remove the wing joint assembly panel
- (3) Remove part of the main fuel vent pipe passing over the tank
- (4) Remove the vent valve
- (5) Disconnect the engine vent pipe
- (6) Disconnect the oil return pipe, feathering pipe and feed pipe (not illustrated) from the filter unit
- (7) Release the straps at the turnbuckles
- (8) Remove the strap guard plate
- (9) Remove the bolts securing the retaining brackets (bottom right hand detail) and remove the brackets with the blocks and the strap retaining plates
- (10) Lift the tank from the support brackets

Fig. 9. Removal of inboard oil tank

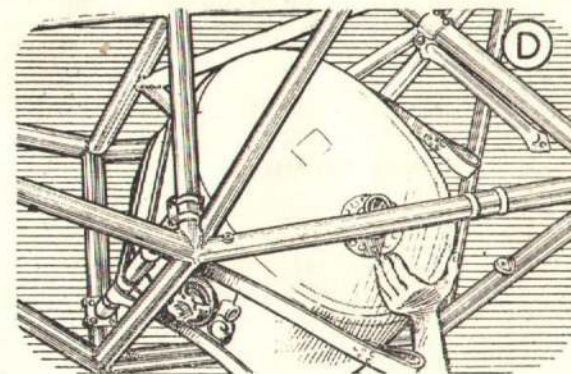
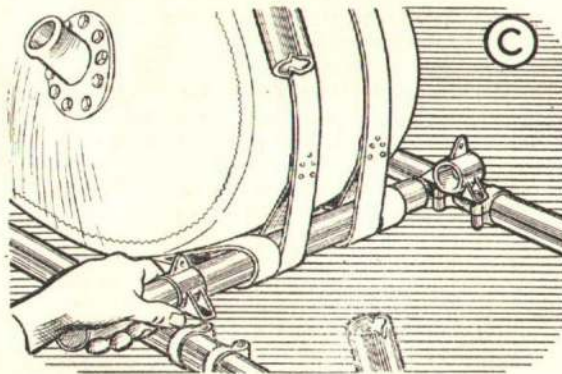
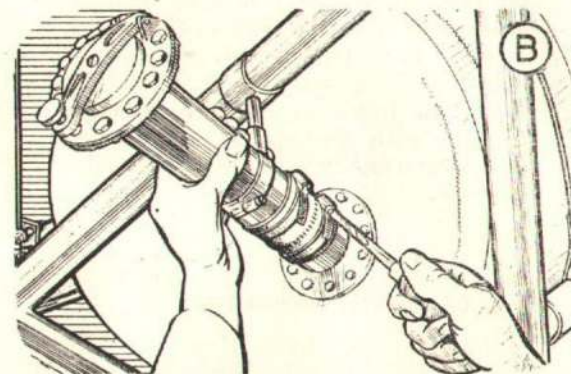
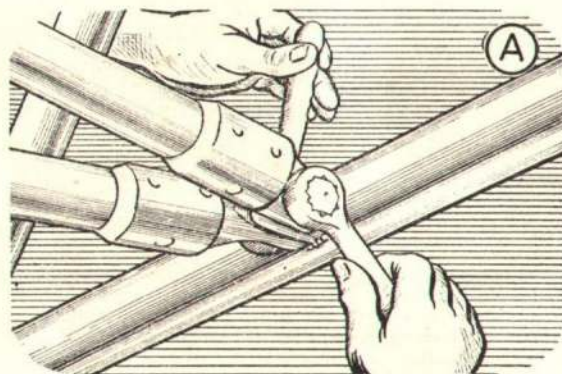
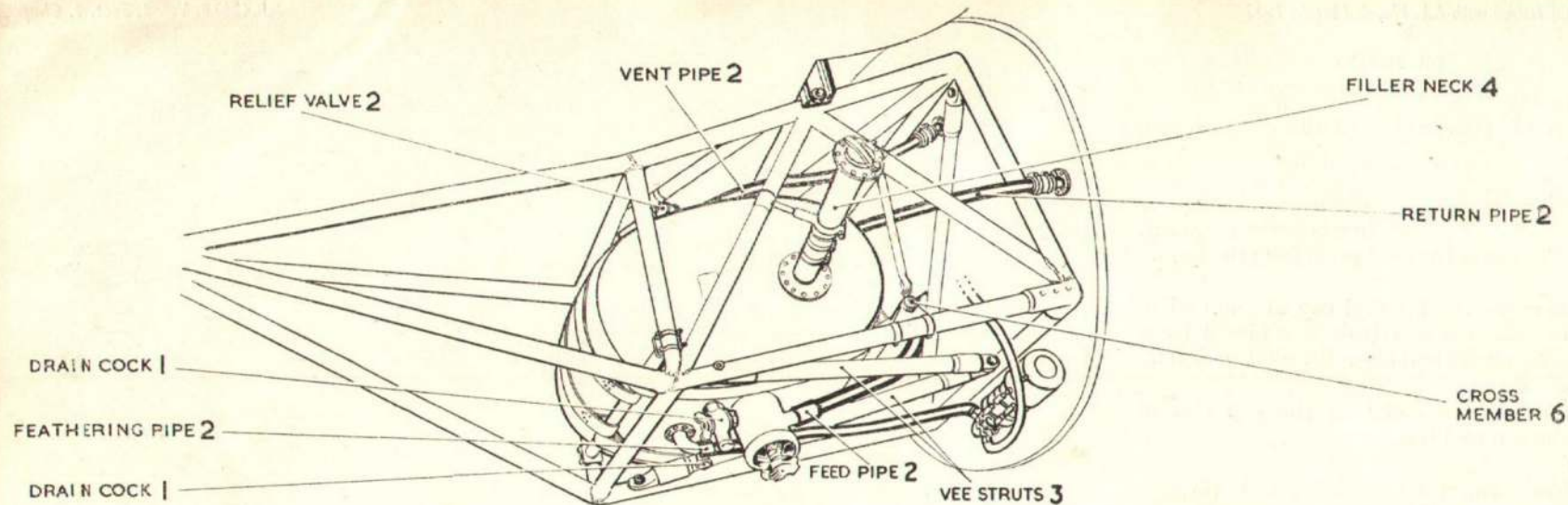

- (1) Drain the tank (refer to text)
- (2) Remove the relief valve and disconnect the oil pipes
- (3) Remove the vee struts (detail A)
- (4) Slacken the lower hose clips (detail B) and detach the filler neck
5. Loosen the strap turnbuckles on the top of the tank
- (6) Remove the bolts from the cross-member bracket and withdraw the cross-member tube (detail C)
- (7) Remove the tank (detail D)

Fig. 10. Removal of outboard oil tank

RESTRICTED

This file was downloaded
from the RTFM Library.

Link: www.scottbouch.com/rtfm

Please see site for usage terms,
and more aircraft documents.

