

SHACKLETON Mk. 2

GROUND EQUIPMENT

Ref. No.	Part No.	Description				No. off	Matl. Spec.	Cl. of St.	Plate and Illust'n No.
		1	2	3	4			M.R.	
		EQUIPMENT GROUND Consisting of :— AIRCRAFT TOOL KIT (Z6991) Consisting of :—							
4G4131	Turner F29B	Adaptor, U/c oleo leg, pressure check ...				1	—	A	
27D/2741	1Z4261	COVER, ENGINE, GROUP (Pre-Mod. 546)				4	—	A	45/1
27D/3039	1Z8661	COVER, ENGINE, GROUP (Mod. 546)				4	—	A	45/1
27D/2750	1Z4262	COVER, SPINNER GROUP ...				4	—	A	45/2
27D/2749	1Z5625	COVER, MAINWHEEL GROUP ...				2	—	A	45/3
27D/2885	2Z6562	COVER, NOSE GROUP ...				1	—	A	45/4
27D/2744	1Z4267	COVER, COCKPIT GROUP ...				1	—	A	45/5
27D/2745	1Z4266	COVER, ASTRO-DOME, GROUP ...				1	—	A	45/6
27D/2746	1Z4264	COVER, TURRET MID-UPPER, GROUP				1	—	A	45/7
27D/2666	1Z6127	COVER, PITOT HEAD, GROUP ...				2	—	A	45/8
27D/2840	1Z6448	COVER, AIR INTAKES No. 2 & 3 CABIN HEATING, GROUP				2	—	A	45/9
27D/2884	1Z7023	COVER, TAIL FAIRING FUSELAGE, GROUP				1	—	A	45/10
26EA/4262	1U576	Eyebolt, picketing ...				2	—	C	45/11
4G/2508	—	Gauge, tyre 10-80 lb. sq. inch ...				1	—	A	
4G/2509	—	Gauge, tyre 10-120 lb. sq. inch ...				1	—	A	
4G/3029	—	Gauge, pressure oleo check 0-3500 lb. sq. in.				1	—	A	
4909	1U999	PIN AILERON & ELEVATOR LOCKING, GROUP				2	—	C	45/12
27D/2883	1Z7029	PLUG, AIR INTAKE No. 1 CABIN HEATING, GROUP				1	—		45/13
6A/2679	—	Plug, static vent ...				2	—	C	
27D/2889	3Z6562	Sleeve, gun ...				2	—	C	45/14
26EA/4306	1Z1436	Spanner, radiator drain plug ...				1	—	A	45/15

GROUND EQUIPMENT

Ref. No.	Part No.	Description				No. off	Matl. Spec.	Cl. of St.	Plate and Illust'n No.
		1	2	3	4			M.R.	
		FLIGHT TOOL KIT (Z6990)							
		Consisting of:—							
26EA/19842	1Z6053	Drill, pop rivet	1	—	A	45/16
1L/48	Britool E.97	Extension, 6" for outboard engine attachment nuts				1	—		
26EA/33015	1Z3847	Extractor, for flap link gudgeon pins	...			1	—	A	45/17
1L/10	Britool A.74	Handle, ratchet	1	—	A	
7504	29.O.3453	HANDLE ENGINE TURNING, GROUP				1	—		45/18
367	1Z6880	KEY BOX, FOR SPARK PLUG NUT ON DANIEL HEATER, GROUP				1	—	A	45/19
		Consisting of:—							
	3Z6880	Bar, tommy	1	—		
	2Z6880	Spanner	1	—		
		KIT, TOOL FOR SERVICING DE-HAVILLAND PROPELLERS							
		Type 1D.334-336-1-1-1-0							
322	1Z4906	Peg, rigging check	2	—	A	45/20
	Seegar S.I.S.	Pliers, circlip for flap links	1	—	A	
1B/4428 3A/1854	1Z1474	Riveter, pop & pump	1	—	A	
7502	18.O.3453	SHAFT, FOR HANDLE ENGINE TURNING, GROUP				1	—		45/21
		Consisting of:—							
	19.O.3453	BRACKET, CLAMP SHAFT, GROUP				1	—		45/22
	AGS.159/3	Pin, taper	4	—		
	25.O.3453	Shaft	1	T26		
	26.O.3453	Sleeve	2	—		
1L/45	Britool EB 1200	Socket, bihexagonal $\frac{11}{16}$ " Whit. For outboard engine attachments nuts				1	—	A	
	Britool AU 445	Socket, bihexagonal $\frac{1}{4}$ " BSF. For fuselage transport joints				1	—		
26EA/32635	1Z2877	Spanner, for wing attachment. Front spar inboard				1	—	A	45/23
26EA/32636	1Z2878	Spanner, for wing attachments. Rear spar inboard				1	—	A	45/24

SHACKLETON Mk. 2

GROUND EQUIPMENT

Ref. No.	Part No.	Description				No. off	Matl. Spec.	Cl. of St.	Plate and Illust'n No.
		1	2	3	4			M.R.	
		EQUIPMENT GROUND							
		Consisting of :—							
		AIRCRAFT TOOL KIT (Z6991)							
		Consisting of :—							
4G4131	Turner F29B	Adaptor, U/c oleo leg, pressure check ...				1	—	A	
27D2741	1Z4261	COVER, ENGINE GROUP ...				4	—	A	45/1
27D/2750	1Z4262	COVER, SPINNER GROUP ...				4	—	A	45/2
27D/2749	1Z5625	COVER, MAINWHEEL GROUP ...				2	—	A	45/3
27D/2885	2Z6562	COVER, NOSE GROUP ...				1	—	A	45/4
27D/2744	1Z4267	COVER, COCKPIT GROUP ...				1	—	A	45/5
27D/2745	1Z4266	COVER, ASTRO-DOME, GROUP ...				1	—	A	45/6
27D/2746	1Z4264	COVER, TURRET MID-UPPER, GROUP				1	—	A	45/7
27D/2666	1Z6127	COVER, PITOT HEAD, GROUP ...				2	—	A	45/8
27D/2840	1Z6448	COVER, AIR INTAKES No. 2 & 3 CABIN HEATING, GROUP				2	—	A	45/9
27D/2884	1Z7023	COVER, TAIL FAIRING FUSELAGE, GROUP				1	—	A	45/10
26EA/4262	1U576	Eyebolt, picketing ...				2	—	C	45/11
4G/2508	—	Gauge, tyre 10-80 lb. sq. inch ...				1	—	A	
4G/2509	—	Gauge, tyre 10-120 lb. sq. inch ...				1	—	A	
4G/3029	—	Gauge, pressure oleo check 0-3500 lb. sq. in.				1	—	A	
	1U999	PIN AILERON & ELEVATOR LOCKING, GROUP				2	—		45/12
27D/2883	1Z7029	PLUG, AIR INTAKE No. 1 CABIN HEATING, GROUP				1	—		45/13
6A/2679	—	Plug, static vent ...				2	—	C	
27D/2889	3Z6562	Sleeve, gun ...				2	—	C	45/14
26EA/4306	1Z1436	Spanner, radiator drain plug ...				1	—	A	45/15

GROUND EQUIPMENT

Ref. No.	Part No.	Description				No. off	Matl. Spec.	Cl. of St.	Plate and Illust'n No.
		1	2	3	4			M.R.	
		FLIGHT TOOL KIT (Z6990)							
		Consisting of:—							
26EA/19842	1Z6053	Drill, pop rivet	1	—	A	45/16
1L/48	Britool E.97	Extension, 6" for outboard engine attachment nuts				1	—		
26EA/33015	1Z3847	Extractor, for flap link gudgeon pins	...			1	—	A	45/17
1L/10	Britool A.74	Handle, ratchet	1	—	A	
	29.O.3453	HANDLE ENGINE TURNING, GROUP				1	—		45/18
367	1Z6880	KEY BOX, FOR SPARK PLUG NUT ON DANIEL HEATER, GROUP				1	—	A	45/19
		Consisting of:—							
	3Z6880	Bar, tommy	1	—		
	2Z6880	Spanner	1	—		
		KIT, TOOL FOR SERVICING DE-HAVILLAND PROPELLERS							
		Type 1D.334-336-1-1-1-0							
322	1Z4906	Peg, rigging check	2	—	A	45/20
	Seegar S.I.S.	Pliers, circlip for flap links	1	—	A	
1B/4428 3A/1854	1Z1474	Riveter, pop & pump	1	—	A	
	18.O.3453	SHAFT, FOR HANDLE ENGINE TURNING, GROUP				1	—		45/21
		Consisting of:—							
	19.O.3453	BRACKET, CLAMP SHAFT, GROUP				1	—		45/22
	AGS.159/3	Pin, taper	4	—		
	25.O.3453	Shaft	1	T26		
	26.O.3453	Sleeve	2	—		
1L/45	Britool EB 1200	Socket, bihexagonal $\frac{11}{16}$ " Whit. For outboard engine attachments nuts				1	—	A	
	Britool AU 445	Socket, bihexagonal $\frac{1}{4}$ " BSF. For fuselage transport joints				1	—		
26EA/32635	1Z2877	Spanner, for wing attachment. Front spar inboard				1	—	A	45/23
26EA/32636	1Z2878	Spanner, for wing attachments. Rear spar inboard				1	—	A	45/24

SHACKLETON Mk 2

GROUND EQUIPMENT

Ref. No.	Part No.	Description				No. off	Matl. Spec.	Cl. of St.	Plate and Illust'n No.
		1	2	3	4			M.R.	
FLIGHT TOOL KIT (Z6990) (Cont'd.)									
26EA/16996	1Z2501	Spanner, for wing attachments. Front and rear spar outboard				1	—	A	45/25
26EA/32641	1Z3245	Spanner, for Fuel system				1	—	A	46/26
26EA/32642	2Z3245	Spanner, for Fuel system				1	—	A	46/27
26EA/32643	1Z3246	Spanner, for Fuel system				1	—	A	46/28
26EA/32644	2Z3246	Spanner, for Fuel system				1	—	A	46/29
26EA/32638	1Z3254	Spanner, for Fuel system				1	—	A	46/30
26EA/32645	1Z3247	Spanner, for Fuel system				1	—	A	46/31
26EA/32649	1Z3251	Spanner, 3/4" for hydraulic and Fuel system				2	—	A	46/32
26EA/32637	1U779	Spanner, for pulsometer pumps				1	—	A	46/33
26EA/3819	1Z1268	Spanner, 'C' for Flap links				2	—	A	46/34
26EA/33017	1Z3956	Spanner, for aileron hinge bolt				2	—	A	46/35
362	1Z6063	Spanner, for tank selector cock No. 3 & 4 tanks				1	—	A	46/36
363	1Z6130	Spanner, claw for 1/8" BSF connections on wing root panel				1	—	A	46/37
364	1Z6131	Spanner, claw for 1/4" BSF hydraulic connections on wing root panel				1	—	A	46/38
365	1Z6132	Spanner, claw for 3/8" BSF hydraulic connections on wing root panel				1	—	A	46/39
366	1Z6133	Spanner, claw for 5/8" BSF hydraulic connection on wing root panel				1	—	A	46/40
1L/24	—	Spanner, double ended, open jaw ...				1	—	A	
1L/25	—	Spanner, double ended, open jaw ...				1	—	A	
1L/26	—	Spanner, double ended, open jaw ...				1	—	A	
1L/59	—	Spanner, double ended, open jaw ...				1	—	A	
1C/5030	—	Spanner, double ended, open jaw ...				1	—	A	
1C/6182	—	Spanner, adjustable				1	—	A	
1C/6183	—	Spanner, C adjustable				1	—	A	
377	1Z7341	Spanner, box, for tailplane centre joint ...				1	—	A	46/41

GROUND EQUIPMENT

Ref. No.	Part No.	Description				No. off	Matl. Spec.	Cl. of St.	Plate and Illust'n No.
		1	2	3	4			M.R.	
		FLIGHT TOOL KIT (Z6990) (Cont'd.)							
369	1Z6887	SPANNER, FOR STARTER MOTOR CONNECTIONS ON FWD. SIDE OF ENGINE BULKHEAD GROUP				1	—	A	46/42
		Consisting of:—							
	2Z6887	Spanner				1	T45		
	3Z6887	Bar, tommy				1	—		
368	1Z6888	Spanner, for spark plug lead on Daniel heater				1	S1	A	46/43
380	1Z7266	SPANNER, FOR SPINDLE STOP IN OIL FILTER, GROUP				1	—	A	46/44
		Consisting of:—							
	3Z7266	Bar, tommy				1	—		
	2Z7266	Tube				1	T45		
379	1Z7190	SPANNER, FOR ACCUMULATOR ATTACHMENT NUTS, GROUP						A	46/45
		Consisting of:—							
	3Z7190	Bar, tommy				1	—		
	2Z7190	Tube				1	T45		
371	1Z6925	TOOL, DRAW, FOR RUDDER HINGE BRACKET BUSHES, GROUP				1	—	A	46/46
		Consisting of:—							
	2Z6925	Bolt, c/w nut				1	—		
	6Z6925	Nut, $\frac{3}{4}$ " dia.				1	S1		
	5Z6925	Plug, flanged				1	S1		
	4Z6925	Thumbscrew				1	S3 or S6		
	3Z6925	Tube				1	T35		
28W/12253	SP13/E	Washer, $\frac{1}{4}$ " BSF				1	—	C	

GROUND EQUIPMENT

Ref. No.	Part No.	Description				No. off	Matl. Spec.	Cl. of St.	Plate and Illust'n No.
		1	2	3	4			M.R.	
HANDLING & STORAGE									
Consisting of:—									
346	Rolls Royce J.D.2545					1	—	A	
347	Rolls Royce J.D.2546					1	—	A	
349	Rolls Royce J.D.2742					1	—	A	
350	Rolls Royce J.D.2743					1	—	A	
331	1.U.923					1	—	A	47/47
348	1.U.956					1	—	A	47/48
4G/4042	—					1	—	A	
4G/4230	—					1	—	A	
JACKING, AIRCRAFT									
Consisting of:—									
4G/2616	—					1	—	A	
4G/2320	—					1	—	A	
4Q/2610	—					2	—	A	
4Q/1309	—					1	—	A	
26EA/33069	2.U.796					2	—	A	47/19
372	1.U.1087					1	—	A	47/50
4Q/2612	—					2	—	A	
4Q/2614	—					1	—	A	
4Q/2615	—					1	—	A	
POWER PLANT CHANGING									
Consisting of:—									
4L/2015						1	—	A	
26EA/32084	1.U.746					1	—	A	47/51
GANTRY POWER PLANT CHANGING GROUP									
Spares for:—									
26EA/17471	10.U.634					2	—	C	47/52
26EA/17472	11.U.634					2	—	C	47/53
28D/13555	A25/8L					4	—	C	47/54
	2.U.746					2	—		47/55
	3.U.746					1	—		47/56
	6.U.634					1	—		47/57
26EA/17468	3.U.634					2	—	C	47/58
26EA/16441	1.U.646					1	—	C	47/59
	7.U.634					1	—		47/60
	8.U.634					2	—		47/61
26EA/18359	1.U.648					1	—	C	47/62
	1.U.747					1	—		47/63
	1.U.749					2	—		47/64
	1.U.750					1	—		47/65
	2.U.750					1	—		47/66
	1.U.751					1	—		47/67
	2.U.751					1	—		47/68
	1.U.755					1	—		47/69

GROUND EQUIPMENT

Ref. No.	Part No.	Description				No. off	Matl. Spec.	Cl. of St.	Plate and Illust'n No.
		1	2	3	4			M.R.	
POWER PLANT CHANGING (Cont'd.)									
319	1.U.906	MAT, WALKING, OUTBOARD ENGINE NACELLE, GROUP				1	—	A	47/70
318	1.U.908	MAT, WALKING, INBOARD ENGINE NACELLE, GROUP				1	—	A	47/71
317	1.U.916	PLATFORM ERECTING ENGINE CHANGING GANTRY, GROUP				1	—	A	47/72
Spares for :—									
4G/2350	9.U.743	Bolt, hook				2	—		
	10.U.743	Nut				2	—		
4G/4170	—	Sling, engine griffen, alternative ...				1	—	A	
4G/1	Rolls Royce J.D.2543	Sling, engine, griffen 57 P. Plant ...				1	—	A	
4G/4349	—	STAND, ENGINE ERECTING IN LINE, TYPE "A"				1	—	A	
Consisting of :—									
4G/2421	—	Adaptor, type "C"				1	—	A	
4G/2188	—	SETS, MODIFICATION				1	—	A	
4G/2189	—	Consisting of :—							
4G/2190	—	Bars, angle				2	—	A	
29A/551	—	Bearer, engine L.H.				1	—	A	
4G/2352	—	Bearer, engine R.H.				1	—	A	
4G/2353	—	Bolt, Whit hex.hd. $\frac{5}{8}$" x $5\frac{1}{2}$" long ...				8	—	C	
29A/1234	—	Cleat, angle L.H.				2	—	A	
29C/1824	—	Cleat, angle R.H.				2	—	A	
		Nut, Whit $\frac{5}{8}$" hex.				8	—	C	
		Washer, for $\frac{5}{8}$" bolt				8	—	C	
STAND, POWER PLANT WITHOUT PROPELLER									
Consisting of :—									
40B/337	—	Adaptor, type 1.				1	—	A	
40B/476	—	Plate, back type "A"				1	—	A	
40B/1014	—	Stand, power plant, type "D" ...				1	—	A	
344	1.U.969	STRUT, EXTENSION PROP. CHANGING, OUTER, GROUP				1	—	A	47/73
345	1.U.970	STRUT, EXTENSION PROP. CHANGING, INNER, GROUP				1	—	A	47/74

SHACKLETON Mk. 2

GROUND EQUIPMENT

Page 561

Ref. No.	Part No.	Description				No. off	Matl. Spec.	Cl. of St.	Plate and Illust'n No.
		1	2	3	4			M.R.	
		RIGGING, EQUIPMENT, FOR COMPLETE AIRCRAFT (B1539)							
		Consisting of :—							
26EA/4319	1Z1427	Board , straight edge fuselage longitudinal check				1	—	A	47/75
26EA/3848	1Z1275	JIG, INCIDENCE, MAINPLANE CENTRE SECTION, GROUP				1	—	A	47/76
26EA/32093	1Z2750	JIG, INCIDENCE, MAINPLANE INNER, RIB No. 3, GROUP				1	—	A	47/77
26EA/32094	1Z2751	JIG, INCIDENCE, MAINPLANE INNER, RIB No. 16, GROUP				1	—	A	47/78
26EA/32095	1Z2752	JIG, INCIDENCE, MAINPLANE OUTER, RIB No. 21, GROUP				1	—	A	47/79
26EA/32096	1Z2753	JIG, INCIDENCE, MAINPLANE OUTER, RIB No. 36, GROUP				1	—	A	47/80
26EA/32098	1Z2754	JIG, INCIDENCE, WING TIP, RIB No. 39, GROUP				1	—	A	47/81
26EA/32097	1Z2765	JIG, DIHEDRAL, MAINPLANE REAR SPAR, GROUP				1	—	A	47/82
320	1Z4899	JIG, INCIDENCE, TAILPLANE RIB No. 3, GROUP				1	—	A	47/83
321	1Z4900	JIG, INCIDENCE, TAILPLANE RIB No. 11, GROUP				1	—	A	47/84
324	1Z4901	JIG, TRANSVERSE CHECK, FORMER 12, GROUP				1	—	A	47/85
323	1Z4902	JIG, TRANSVERSE, CHECK, FORMER 37, GROUP				1	—	A	47/86
326	1Z4903	JIG, FIN CHECK, GROUP				1	—	A	47/87
327	1Z4910	JIG, SETTING, RUDDER TO FIN, GROUP				1	—	A	47/88
325	1Z4911	JIG, SETTING, ELEVATOR, GROUP				1	—	A	47/89

Ref. No.	Part No.	Description				No. off	Matl. Spec.	Cl. of St.	Plate and Illust'n No.
		1	2	3	4			M.R.	
TESTING & SERVICING									
4G/4131	—	Consisting of :— Adaptor , inflation				1	—	A	
4G/4339	—	ADAPTOR, FOR METHANOL WATER SYSTEM GROUND TESTING, GROUP				1	—	A	
4G/4340	—	Consisting of :— Adaptor , $\frac{3}{8}$ " BSF				1	—	A	
4G/4341	—	Washer , sealing				1	—	A	
4G/1203	—	Balance , spring 30 lbs.				1	—	A	
4L/536	—	Block , pulley, hoisting scanner				1	—	A	
4L/537	—	Block , pulley, hoisting scanner				1	—	A	
4G/2597	—	Box , extension 2' 6" use with platform for fitting guns				1	—	A	
4G/2598	—	Box , extension 1' 6" use with platform for fitting guns				1	—	A	
381	1U1083	CLAMP, JURY LOCKING, TAIL-WHEEL JACK, GROUP				1	—	A	47/90
4G/4169	—	Cleaner , vacuum, aircraft, heavy duty Mk 1A				1	—	A	
26EA/32107	Dunlop AH8364	Extractor , wheel				1	—	A	
4G/4182	—	Gauge , pressure testing water methanol system				1	—	A	
4G/3026	—	Gauge , pressure 0-600 lbs. sq. inch, use with inflation adaptor				1	—	A	
4G/3027	—	Gauge , pressure 0-1500 lbs. sq. inch, use with inflation adaptor				1	—	A	
4G/3029	—	Gauge , pressure 0-3500 lbs. square inch, use with inflation adaptor				1	—	A	
26EA/4274	1U575	LADDER, MAINTAINANCE, GROUP				1	—	A	47/91
		Spares for :—							
	1U601	Board , face				1	—		
	2U575	Bolt				2	—		47/92
	1U581	Cable , bracing				1	—		47/93
26EA/4276	1U578	Ladder , lower portion				1	—	C	
26EA/4277	1U579	Ladder , top portion				1	—	C	
26EA/4278	1U582	Pin , quick release				2	—	C	47/94
28P/832	SP4Y/B6	Pin , solid $\frac{3}{16}$ " dia.				2	—	C	
13638	1U580	Platform				2	—	C	
26EA/19659	1U592	Plate , base front				1	—	C	
26EA/19660	2U592	Plate , base rear				1	—	C	

SHACKLETON Mk. 2

GROUND EQUIPMENT

Ref. No.	Part No.	Description				No. off	Matl. Spec.	Cl. of St.	Plate and Illust'n No.
		1	2	3	4			M.R.	
TESTING & SERVICING (Cont'd)									
4G/4243	—					1	—	A	
4G/4342	—					1	—	A	
33C/1115	—					1 box	—	C	
4G/2604	—					1	—	A	
4G/2596	—					1	—	A	
4G/4269	—					QR	—	A	
4G/257	—					1	—	A	
4G/3821	—					1	—	A	
328	1U899					4	—	A	47/95
Spares for :—									
6639	2U567					1	—		47/96
	3U899					2	—		47/97
313	1U814					4	—	A	47/98
5177									
STRUT, JURY, UNDERCARRIAGE, GROUP									
Spares for :—									
26EA/2812	8U566					2	—	C	47/99
	1U567					1	—		47/100
4A/1757	—					1	—	A	
4F/1718	—					1	—	A	
4F/1693	—					1	—	A	
4F/1690	—					1	—	A	
4F/172	—					1	—	A	
4F/1715	—					1	—	A	
4F/36	—					1	—	A	
4G/4230	—					1	—	A	
4G/4200	—					1	—	A	
4G/4221	—					1	—	A	
4G/4422	—					1	—	A	
4G/4423	—					1	—	A	

GROUND EQUIPMENT.

Ref. No.	Part No.	Description				No. off	Matl. Spec.	Cl. of St.	Plate and Illust'n No.
		1	2	3	4			M.R.	
		TOWING & STEERING							
		Consisting of :—							
336	1U971	ADAPTOR, INTERMEDIATE FOR TAIL TOWING, ARM, GROUP				1	—	A	48/101
352	1U1007	ADAPTOR, FORK TOWING ARM, GROUP				1	—	A	48/102
		Consisting of :—							
	3U1007	Attachment, swivel port				1	—		
	4U1007	Attachment, swivel starboard				1	—		
	5U1007	Bar, swivel attachment				1	—		
28D/12641	A25/25G	Bolt, hex.hd, $\frac{5}{16}$" BSF				6	—	C	
28D/14007	A25/31N	Bolt, hex.hd, $\frac{1}{2}$" BSF				2	—	C	
	8U1007	Cable, (3 cwt. x 12" long)				2	W2		
	6U1007	Chain, 8" long				4	V9		
	2U1007	Frame				1	—		
	4SS1585	Lug				2	—		
28M/13259	A27/NS	Nut, slotted $\frac{7}{8}$" BSF				2	—	C	
28M/1006939	A27/GP	Nut, $\frac{5}{8}$" BSF				6	—	C	
	AS2445/35	Pin, quick release				2	—		
	AS2438/37	Pin, quick release $\frac{1}{2}$" dia.				4	—		
28P/1007741	SP9/C.8	Pin, split				4	—	C	
	7U1007	Ring, split				8	—		
	3U940	Sleeve				2	—		
4G/2792	—	Arm, towing tailwheel (used with adaptor 1U971 & adaptor fork 1U1007)				1	—	A	
333	1U939	ARM, TOWING TAILWHEEL, GROUP (Used with adaptor fork 1U1007 only)				1	—	A	48/103
		Spares for :—							
	1U941	ABSORBER, SHOCK, GROUP				1	—		48/104
		(When it is necessary to repair or service the shock absorber, the whole towing arm must be returned to the makers)							
		Spares for :—							
	43U941	Arm, release mechanism				1	—		
	23U941	Arm, lever				1	DTD124A		
	47U941	Bar, link				1	—		
	6U941	Block, bearer				2	L45		
	7U941	Block, bearer				3	L45		
	8U941	Block, bearer				1	—		
	9U941	Bolt, hex.hd, $\frac{3}{8}$" BSF				24	—		
	39U941	Bolt, hex.hd, $\frac{1}{2}$" BSF				2	—		
	20U941	Bolt, hex.hd, $\frac{3}{8}$" BSF				1	—		
	33U941	Bolt, hex.hd, $\frac{3}{8}$" BSF				3	—		
	49U941	Buffer, $1\frac{1}{2}$" x $1\frac{1}{4}$" x $\frac{1}{2}$" thick				2	Rubber		
	45U941	Cable, release				1	—		

SHACKLETON Mk. 2

GROUND EQUIPMENT

Ref. No.	Part No.	Description				No. off	Matl. Spec.	Cl. of St.	Plate and Illust'n No.
		1	2	3	4			M.R.	
		ABSORBER, SHOCK, GROUP (1U941) (Cont'd)							
	21U941					1	—		
	22U941					1	—		
	46U941					1	—		
	14U941					1	—		
	42U941					1	—		
	26U941					4	DTD124A		
	32U941					2	—		
	17U941					1	—		
	16U941					1	—		
	28U941					1	—		
	12U941					130	Rubber		
	29U941					2	—		
	15U941					2	—		
	40U941					1	—		
	66U939					1	—		
	47U939					1	—		
	36U939					16	—		
	67U939					2	—		
4G/3619	—					2	—		A
	1U1149					1	—		
95552	64U939					1	—		C
	65U939					1	—		
28FP/12	A419					1	—		C
	49U939					1	—		
	46U939					1	—		
	42U939					1	—		
4G/3620	—					2	—		A
4G/3621	—					2	—		A
	Flexello 5HR150					1	—		
353	1U1010	ARM, STEERING, TAILWHEEL, GROUP				1	—	A	48/105
		Spares for :—							
	3U1010					1	—		
	4U1010					1	—		
	5U1007					1	—		
	19U572					2	—		
	AS2438/25					4	—		
	16U572					2	—		
4G/4139	GS2151					1	—	A	
301	1U813	CABLE, TOWING, REAR, MAIN UNDERCARRIAGE, GROUP				1	—	A	48/106
		Spares for :—							
	3U813					1	—		
26EA/4278	1U582					1	—	C	48/94

GROUND EQUIPMENT

Ref. No.	Part No.	Description				No. off	Matl. Spec.	Cl. of St.	Plate and Illust'n No.
		1	2	3	4			M.R.	
		TRESTLING & SLINGING, COMPLETE AIRCRAFT & COMPONENTS (U898) Consisting of :—							
303	1U890	BEAM, FOR TAIL POSITION, AT FORMER 41, USED WITH Y.J.T. 15, AND SCANNER RETRACTION TEST USED WITH U.J.T. No. 17, GROUP				2	—	A	48/107
304	1U891	BEAM, FOR REAR SECTION FUSELAGE POSITION, AT FORMER 33, USED WITH U.J.T. 11, GROUP				1	—	A	48/108
332	1U896	BEAM, FOR REAR CENTRE SECTION FUSELAGE POSITION, AT FORMER 29, USED WITH U.J.T. 12, GROUP				1	—	A	48/109
314	1U900	BEAM, FOR NOSE POSITION, AT FORMER E, USED WITH U.J.T. 9A, GROUP				1	—	A	48/110
330	1U921	BEAM, FOR TRESTLING, AND SLINGING TAILPLANE, USED WITH U.J.T. 11 GROUP				1	—	A	48/111
26EA/32091	1U739	BEAM, AT WING RIB, 3, PORT, USED WITH HEAVY GANTRY, GROUP				2	—	A	48/112
26EA/32108	2U739	BEAM, AT WING RIB 3, STARBOARD USED WITH HEAVY GANTRY, GROUP				1	—	A	48/113
26EA/32109	1U765	BEAM, AT WING RIB 16, PORT USED WITH HEAVY GANTRY, GROUP				1	—	A	48/114
26EA/32110	2U765	BEAM, AT WING RIB 16, STARBOARD USED WITH HEAVY GANTRY, GROUP				1	—	A	48/115
26EA/32111	1U766	BEAM, AT WING RIB 21, PORT USED WITH HEAVY GANTRY, GROUP				1	—	A	48/116
26EA/32112	2U766	BEAM, AT WING RIB 21, STARBOARD, USED WITH HEAVY GANTRY, GROUP				1	—	A	48/117
26EA/32113	1U767	BEAM, AT WING RIB 36, PORT, USED WITH HEAVY GANTRY, GROUP				1	—	A	48/118
26EA/32114	2U767	BEAM, AT WING RIB 36, STARBOARD USED WITH HEAVY GANTRY, GROUP				1	—	A	48/119
305	5U883	Eyebolt, for rear section and tail slings ...				1	—	C	48/1
4Q/1245	—	Gantry, heavy type, C/W beam, type "A" (4Q2310)				3	—	A	

GROUND EQUIPMENT

Ref. No.	Part No.	Description				No. off	Matl. Spec.	Cl. of St.	Plate and Illust'n No.
		1	2	3	4			M.R.	
TRESTLING & SLINGING, COMPLETE AIRCRAFT & COMPONENTS (U898) (Cont'd)									
354	1U995	SLING, NOSE FUSELAGE, WITH GUNS, GROUP				1	—	A	48/121
	2U995	BAR, SPREADER, GROUP ...				1	—		48/122
		Consisting of:—							
		Bolt , lifting head $\frac{5}{8}$ " BSF ...				2	—	C	
		Bolt , fork attachment of cables to nose ...				4	—		48/123
		Cable , front and rear ...				4	—		48/124
		Cable , top ...				2	—		48/125
		Head , lifting ...				1	—		
		Label ...				1	—		
		Link , cable ...				8	—		48/126
		Link , cable ...				4	—		48/127
		Nut , slotted $\frac{5}{8}$ " BSF ...				2	—	C	
		Pin , quick release ...				4	—		
		Pin , shackle ...				8	—	C	
		Pin , shackle ...				4	—	C	
		Pin , split, $\frac{3}{32}$ " dia. x 1" long ...				8	—	C	
		Pin , split, $\frac{1}{8}$ " dia. x $1\frac{1}{4}$ " long ...				4	—	C	
		Pin , split, $\frac{1}{8}$ " dia. x $1\frac{1}{2}$ " long ...				2	—	C	
		SLING, NOSE & FRONT CENTRE SECTION, COMBINED GROUP				1	—	A	48/128
		Consisting of:—							
		BAR, SPREADER, GROUP ...				1	—		48/129
		Bolt , attachment of sling at longeron ...				4	—		
		Bolt , lifting head ...				2	—		
		Bracket , cable attachment ...				4	—		
		Cable , top ...				2	—		48/130
		Cable , front ...				2	—		48/131
		Cable , rear ...				2	—		48/132
		Head , lifting ...				1	—		
		Label ...				1	—		
		Link , cable ...				12	—		48/133
		Nut , slotted, 1" BSF ...				2	—		
		Pin , shackle, $\frac{1}{2}$ " dia. ...				12	—	C	
		Pin , shackle, $\frac{1}{2}$ " dia. ...				4	—	C	
		Pin , split $\frac{5}{32}$ " dia. x $1\frac{1}{2}$ " long ...				16	—	C	
		Pin , split $\frac{3}{16}$ " dia. x $2\frac{1}{2}$ " long ...				2	—	C	

GROUND EQUIPMENT

Ref. No.	Part No.	Description				No. off	Matl. Spec.	Cl. of St.	Plate and Illust'n No.
		1	2	3	4			M.R.	
		TRESTLING & SLINGING COMPLETE AIRCRAFT & COMPONENTS (U898) (Cont'd)							
309	1U876	SLING, NOSE & FRONT CENTRE SECTION COMBINED LESS GUNS FRONT CENTRE SECTION, & REAR CENTRE SECTION, C/W TURRET, GROUP				1	—	A	48/134
	2U876	Consisting of :— BAR, SPREADER, GROUP				1	—		48/135
	8U866	Bolt, lifting head				1	—		
	1U897	Bolt, attachment of sling at longeron ...				4	—		
	18U866	Bracket, cable attachment				4	—		
	3U876	Cable, top				2	—		48/136
	4U876	Cable, front				2	—		48/137
	5U876	Cable, rear				2	—		48/138
	2U866	Head, lifting				1	—		
	7U866	Link, cable				4	—		48/133
	13U876	Link, cable				8	—		48/127
	A27/WS	Nut, slotted 1" BSF				2	—	C	
28M/13276	SP4/Y/R17	Pin, shackle $\frac{1}{2}$ " dia.				4	—	C	
28P/6943	SP4/Y/R19	Pin, shackle $\frac{1}{2}$ " dia.				4	—	C	
28P/14017	SP4/Y/M17	Pin, shackle $\frac{1}{2}$ " dia.				8	—	C	
28P/1167	SP9/H12	Pin, split $\frac{5}{32}$ " dia. x $1\frac{1}{2}$ " long				8	—	C	
28P/12720	SP9/K20	Pin, split $\frac{3}{16}$ " dia. x $2\frac{1}{2}$ " long				2	—	C	
28P/12366	SP9/G10	Pin, split, $\frac{1}{8}$ " dia. x $1\frac{1}{4}$ " long				8	—	C	
28P/12464									
306	1U882	SLING, CENTRE SECTION UNDER-CARRIAGE UP, GROUP				1	—	A	48/139
	2U882	Consisting of :— BAR, SPREADER, GROUP				1	—		48/140
	6U882	Bolt, shouldered lifting head				2	—		
	9U882	Bolt, shoulder cable link... ..				4	—		
28D/13053	A25/9N	Bolt, hex.hd. $\frac{1}{4}$ " BSF x 1.7" long				8	—	C	
28D/14008	A25/6S	Bolt, hex.hd. $\frac{1}{4}$ " BSF				4	—	C	
28D/12674	A25/9E	Bolt, hex.hd. $\frac{1}{4}$ " BSF x 1.4" long				8	—	C	
	10U882	Bobbin, cable				2	—		
	4U882	Cable, front				1	—		48/141
	5U882	Cable, rear				1	—		48/142
	3U882	Head, lifting				1	—		
	12U882	Link, cable				4	—		48/143
28M/716	A16Y/SS	Nut, slotted $\frac{3}{4}$ " BSF				2	—	C	
28M/775	A16Y/NS	Nut, slotted $\frac{1}{2}$ " BSF				12	—	C	
28M/756	A16Y/EP	Nut, plain $\frac{1}{4}$ " BSF				8	—	C	
28P/12463	SP9/E10	Pin, split $\frac{3}{32}$ " dia. x $1\frac{1}{4}$ " long				12	—	C	
28P/12721	SP9/H16	Pin, split $\frac{3}{32}$ " dia. x 2" long				2	—	C	
	7U882	Plate, attachment forward				1	—		
	8U882	Plate, attachment rear				1	—		
	11U552	Washer, shoulder bolt				2	—		48/144
	11U882	Washer				4	—		48/145
28W/12253	SP13/E	Washer, $\frac{1}{4}$ " BSF				8	—	C	
28W/3076	AGS160/H	Washer				4	—	C	

SHACKLETON Mk. 2

GROUND EQUIPMENT

Ref. No.	Part No.	Description				No. off	Matl. Spec.	Cl. of St.	Plate and Illust'n No.	
		1	2	3	4			M.R.		
TRESTLING & SLINGING COMPLETE AIRCRAFT & COMPONENTS (U898) (Cont'd)										
356	1U994	SLING, REAR CENTRE SECTION LESS TURRET, GROUP				1	—	A	48/146	
	2U994	BAR, SPREADER, GROUP ...				1	—		48/147	
	8U866	Bolt, lifting head ...				2	—			
	1U897	Bolt, attachment of sling at longeron ...				4	—			
	18U866	Bracket, cable attachment ...				4	—			
	3U876	Cable, top ...				2	—		48/138	
	5U876	Cable, rear ...				2	—		48/136	
	3U994	Cable, front ...				2	—		48/148	
	2U866	Head, lifting ...				1	—			
	1U1005	Label ...				1	—			
	7U866	Link, cable ...				4	—		48/133	
	13U876	Link, cable ...				8	—		48/127	
	28M/13276	A27/WS	Nut, slotted 1" BSF ...				2	—	C	
	28P/5058	AGS784/39	Pin, split $\frac{3}{16}$" x $2\frac{1}{2}$" long ...				2	—	C	
	28P/12720	SP9/H12	Pin, split $\frac{5}{32}$" x $1\frac{1}{2}$" long ...				8	—	C	
28P/12464	SP9/G10	Pin, split $\frac{1}{8}$" x $1\frac{1}{4}$" long ...				8	—	C		
28P/14017	SP4/R19	Pin, shackle $\frac{5}{8}$" dia. ...				4	—	C		
28P/6943	SP4Y/R17	Pin, shackle $\frac{5}{8}$" dia. ...				4	—	C		
28P/1167	SP4Y/M17	Pin, shackle $\frac{1}{2}$" dia. ...				8	—	C		
357	1U992	SLING, REAR SECTION, GROUP ...				1	—	A	48/149	
Consisting of:—										
28D/14009	A25/Q37	Bolt, lifting head $\frac{5}{8}$" BSF ...				2	—	C		
	3U992	Cable, front ...				1	—		48/150	
	4U992	Cable, rear ...				1	—		48/151	
	2U992	Head, lifting ...				1	—			
	5U992	Label ...				1	L4			
	7U866	Link, cable ...				4	—		48/133	
28M/13145	A27/QS	Nut, slotted ...				2	—	C		
	10U883	Pin, quick release ...				2	—			
	28P/14017	4SPY/R19	Pin, shackle $\frac{5}{8}$" dia. ...				2	—	C	
	28P/12720	SP9/H12	Pin, split $\frac{5}{32}$" dia. x $1\frac{1}{2}$" long ...				2	—	C	
	28P/12465	SP9/G12	Pin, split $\frac{1}{8}$" dia. x $1\frac{1}{2}$" long ...				2	—	C	
312	1U887	SLING, TAIL LIFTING, GROUP ...				1	—	A	48/152	
Consisting of:—										
28M/8261	3U887	Bar, spreader ...				1	—		48/153	
	8U866	Bolt, for lifting head ...				2	—			
	2U887	Cable ...				2	—		48/154	
	2U866	Head, lifting ...				1	—			
	28P/5051	A16Y/WS	Nut, slotted, 1" BSF ...				2	—	C	
	28P/5058	AGS784/29	Pin, split, $\frac{5}{32}$" dia. x $1\frac{1}{2}$" long ...				2	—	C	
	28P/5058	AGS784/39	Pin, split, $\frac{3}{16}$" dia. x $2\frac{1}{2}$" long ...				2	—	C	
	28P/14019	SP4/Y/R19	Pin, shackle, $\frac{5}{8}$" dia. ...				2	—	C	
		5U887	Pin, quick release, $\frac{5}{8}$" dia. ...				2	—		

GROUND EQUIPMENT

Ref. No.	Part No.	Description				No. off	Matl. Spec.	Cl. of	Plate and Illust'n No.
		1	2	3	4			St.	
		TRESTLING & SLINGING, COMPLETE AIRCRAFTS & COMPONENTS (U898) (Cont'd)							
315	1U907	SLING, FIN OR RUDDER, GROUP...				1	—	A	48/155
		Consisting of:—							
28D/12834	A25/18N	Bolt, hex.hd, $\frac{1}{8}$ "	BSF	x 2.5" long	...	1	—	C	
28D/7420	A1/18J	Bolt, hex.hd, $\frac{1}{8}$ "	BSF	x 2.4" long	...	2	—	C	
28D/7609	A1/7J	Bolt, hex.hd, $\frac{1}{8}$ "	BSF	x 1.3" long	...	2	—	C	
	3U907	Cable	2	—		48/156
	2U907	Eyebolt	2	—		48/157
	326SS6000	Label	1	—		
	5U907	Link, attachment, cable to eyebolt	2	—		48/158
28M/772	A16Y/JS	Nut, slotted, $\frac{3}{8}$ "	BSF	4	—	C	
28M/775	A16Y/NS	Nut, slotted, $\frac{1}{2}$ "	BSF	2	—	C	
28P/5032	AGS784/3	Pin, split, $\frac{1}{16}$ " dia.	x 1" long	4	—	C	
28P/5039	AGS874/12	Pin, split, $\frac{3}{32}$ " dia.	x 1.25" long	1	—	C	
	SS962/C	Pin, quick release, $\frac{3}{8}$ " dia.	2	—		
	2bU819	Pin, side attachment	2	—		
	6U907	Ring, split, $\frac{1}{2}$ " i/d (stand brass)	2	—		
28Q/10563	AS2229/407	Rivet, csk.hd, 90° hd. $\frac{1}{8}$ " dia.	x $\frac{7}{16}$ " long	4	—	C	
	3U819	Tube, distance	1	—		48/159
	4U819	Tube, distance	2	—		48/160
	5U819	Tube, distance	4	—		48/161
	8U819	Tube, distance	2	—		48/162
	9U819	Tube, distance	4	—		48/163
316	1U918	SLING, TAILPLANE, LESS BEAM, GROUP				1	—	A	48/164
		Consisting of:—							
	2U918	Cable, wire rope, 4' 4.5" long	1	—		48/165
	3U918	Cable, wire rope 4' 6.375" long	1	—		48/166
	5U918	Label	1	—		
	4U867	Link, cable	4	—		48/126
28P/5038	AGS784/11	Pin, split, $\frac{3}{32}$ " dia.	x 1" long	2	—	C	
28P/934	SP4/Y/H12	Pin, shackle	2	—	C	
	SS962/B	Pin, quick release, $\frac{3}{8}$ " dia.	2	—		
28R/5410	AGS890/A	Ring, lifting	1	—	C	
	7U918	Ring, split, $\frac{1}{2}$ " i/d	1	—		
28Y/3005	AGS136/B	Thimble	4	—	C	
30B/571	—	Wire, binding, cable (copper 20 SWG)	QR	—	C	
	—	Wire, retaining (wire rope, 3 cwt., 6" long)	1	—		
26EA/32088	1U760	SLING, MAINPLANE, INNER, GROUP				1	—	A	48/167
		Consisting of:—							
	1U761	Bar, spreader, inboard	1	—		48/168
	2U761	Bar, spreader, outboard	1	—		48/169
	1U745	Beam, lifting	1	—		48/170
	1U762	Sling, lifting	1	—		48/171

SHACKLETON Mk. 2

GROUND EQUIPMENT

Ref. No.	Part No.	Description				No. off	Matl. Spec.	Cl. of St.	Plate and Illust'n No.
		1	2	3	4			M.R.	
		TRESTLING & SLINGING, COMPLETE AIRCRAFT & COMPONENTS (U898) (Cont'd)							
26EA/32089	2U760	SLING, MAINPLANE, OUTER, GROUP				1	—		
		Consisting of:—							
	3U761	Bar, spreader, inboard				1	—		
	4U761	Bar, spreader, outboard				1	—		
	1U745	Beam, lifting				1	—		
	2U762	Sling, lifting				1	—		
375	1U1091	SLING, FOR SCANNER TYPE 85, GROUP				1	—	A	48/176
		Spares for:—							
	2U1091	Bar, spreader				1	—		48/177
	3U1091	Cable, 10 cwt. M.BL.				2	W2		48/178
	6U1091	Hook				2	—		48/179
	7U1091	Spring				2	Spring Steel		48/180
4Q/2611	—	Trestle, Mk. 1, 25 ton				1	—	A	
4G/	—	TRESTLE, JACKING, UNIVERSAL, No. 9A, C/W BRKT., TYPE "A", GROUP				1	—	A	
		Consisting of:—							
4G/2451	—	Body, jacking				2	—	A	
29A/539	—	Bolt				12	—	C	
29A/549	—	Bolt				2	—	C	
4G/795	—	Bracket, type "A" (elongated hole) ...				1	—	C	
4G/2456	—	Bracket, type "A" (round hole) ...				1	—	C	
4G/805	—	Legs				4	—	C	
4G/803	—	Members, cross				2	—	C	
29A1234	—	Nut				18	—	C	
4G/806	—	Rail, bottom				2	—	C	
4G/1479	—	Rail, top				2	—	C	
4G/1470	—	Stay, diagonal				2	—	C	
4G/	—	TRESTLE, JACKING, UNIVERSAL, No. 11, C/W "A" TYPE BRACKETS, GROUP				1	—	A	
4G/	—	TRESTLE, JACKING, UNIVERSAL, No. 17 C/W "A" TYPE BRACKETS, GROUP				1	—	A	
4G/	—	TRESTLE, JACKING, UNIVERSAL, No. 12 C/W "A" TYPE BRACKETS, GROUP				1	—	A	
4G/	—	TRESTLE, JACKING, UNIVERSAL, No. 15, C W "A" TYPE BRACKETS, GROUP				1	—	A	
—	—	TROLLEY FOR LIFEBOAT S.O.O. ...				1	—		

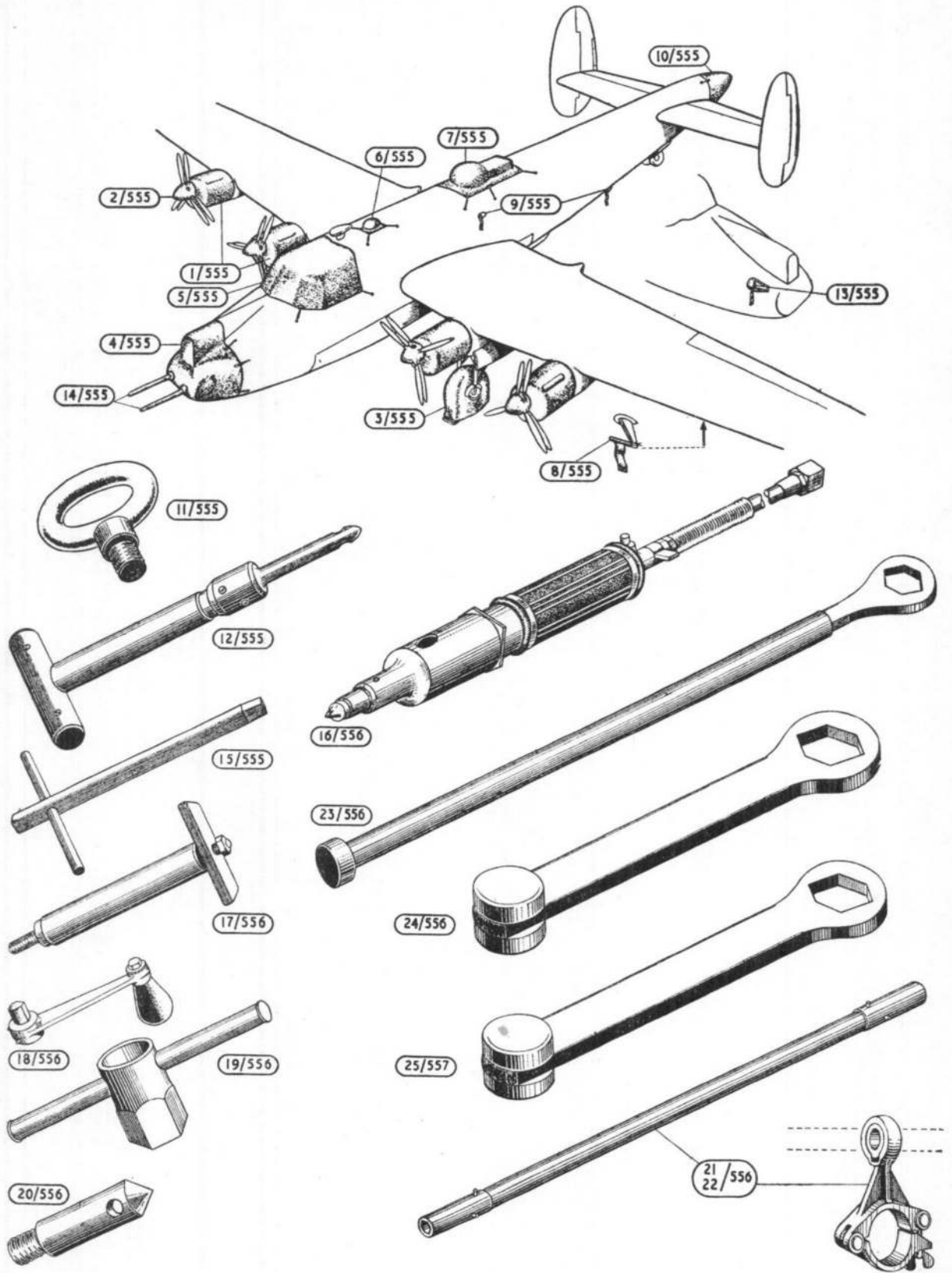

GROUND EQUIPMENT (I)



GROUND EQUIPMENT (U)

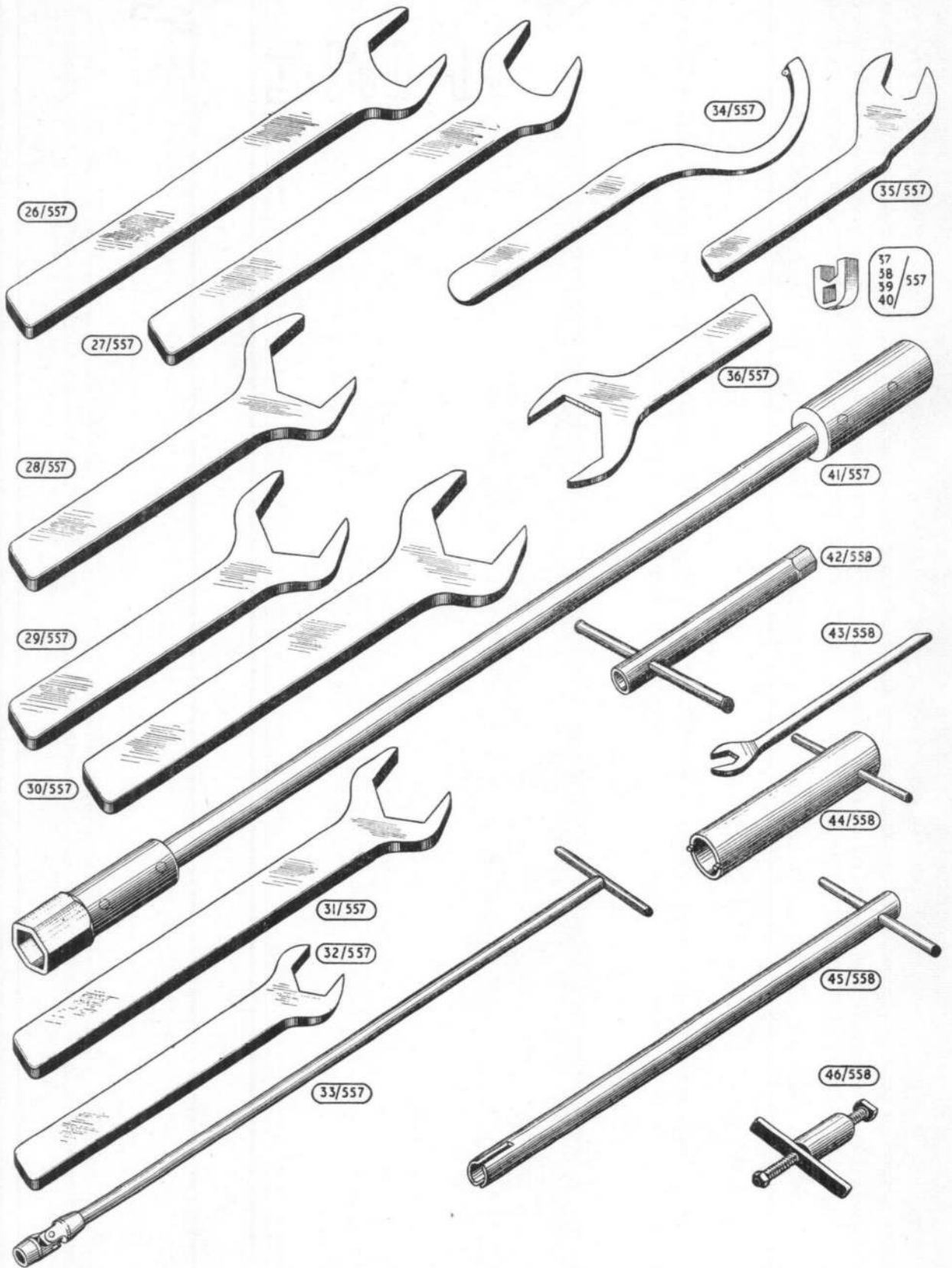

GROUND EQUIPMENT (2)

FORM 302A
FBI

[Faint, illegible handwritten text, possibly bleed-through from the reverse side of the page]

[Faint, illegible text at the bottom of the page]



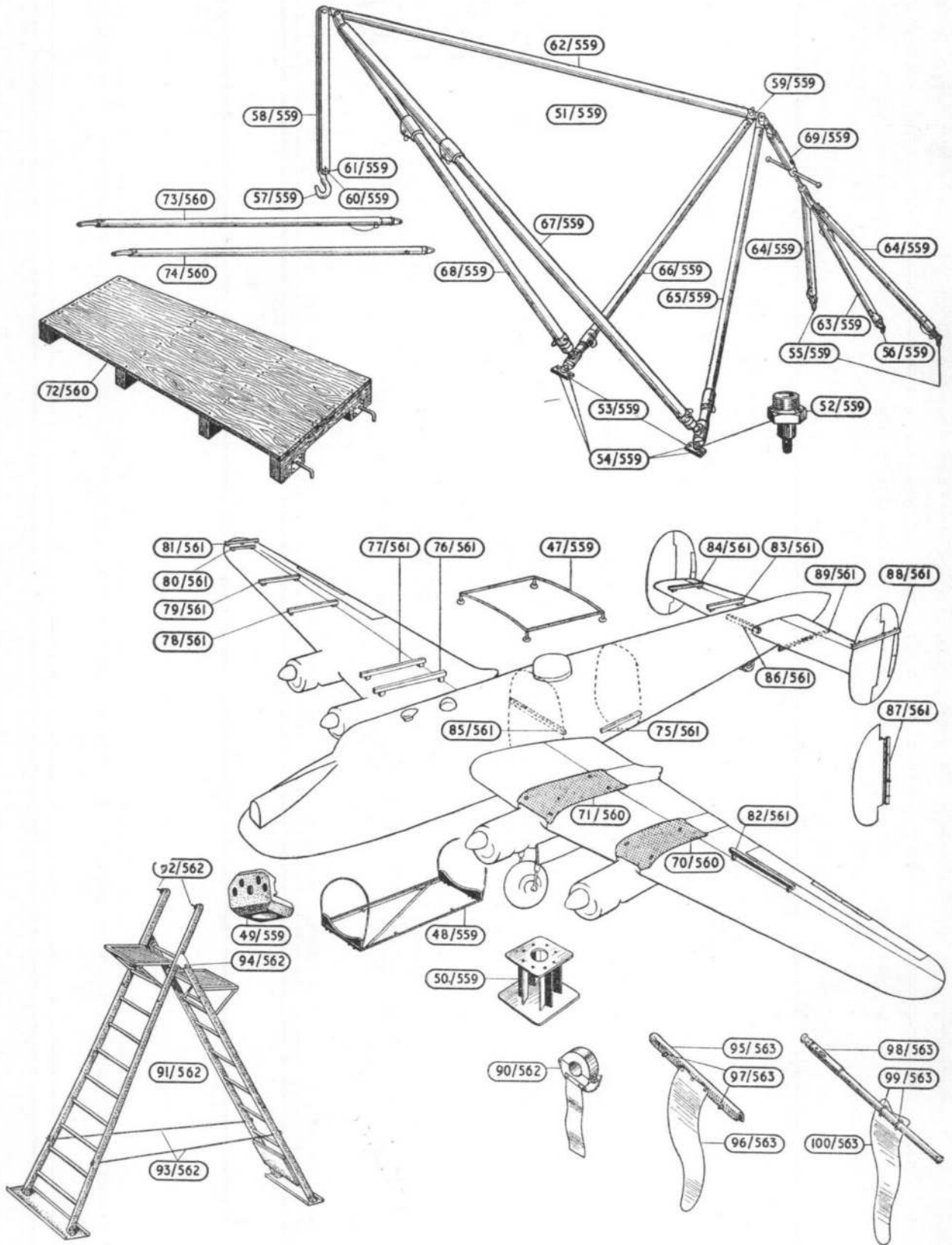

GROUND EQUIPMENT (3)

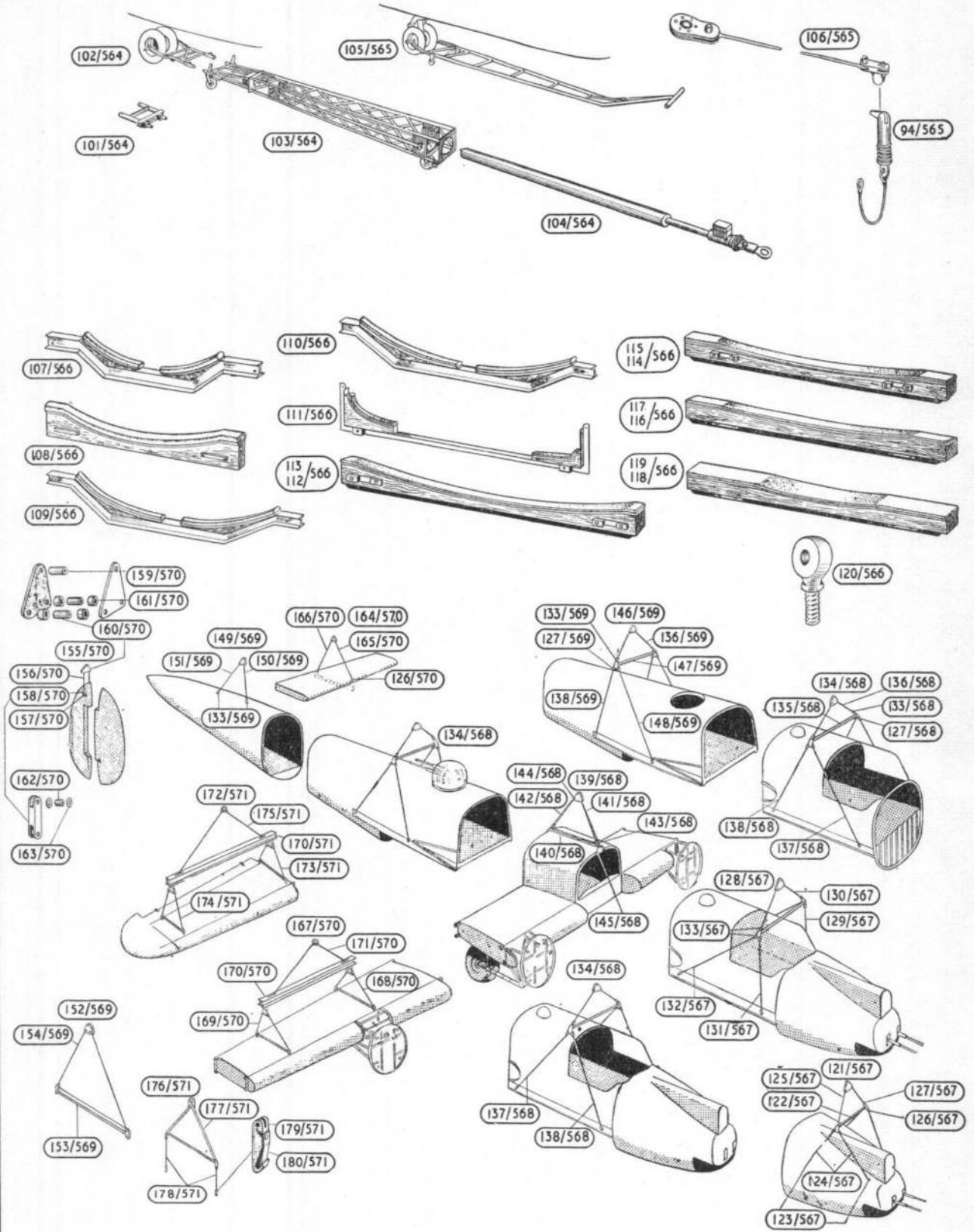

GROUND EQUIPMENT (4)

100-1000

Date	Description	Debit	Credit
10/1/52	Balance		
10/2/52	Cash	100.00	
10/3/52	Cash	200.00	
10/4/52	Cash	300.00	
10/5/52	Cash	400.00	
10/6/52	Cash	500.00	
10/7/52	Cash	600.00	
10/8/52	Cash	700.00	
10/9/52	Cash	800.00	
10/10/52	Cash	900.00	
10/11/52	Cash	1000.00	
10/12/52	Cash	1100.00	
10/13/52	Cash	1200.00	
10/14/52	Cash	1300.00	
10/15/52	Cash	1400.00	
10/16/52	Cash	1500.00	
10/17/52	Cash	1600.00	
10/18/52	Cash	1700.00	
10/19/52	Cash	1800.00	
10/20/52	Cash	1900.00	
10/21/52	Cash	2000.00	

10/21/52

This file was downloaded
from the RTFM Library.

Link: www.scottbouch.com/rtfm

Please see site for usage terms,
and more aircraft documents.

