

SHACKLETON Mk 2

**MAIN PLANES
AILERONS (INBOARD)**

Ref. No.	Part No.	Description				No. off	Matl. Spec.	Cl. of St.	Plate and Illust'n No.
		1	2	3	4			M.R.	
4025 4026	210F5628 212F5628	AILERON, ASSEMBLY, INBOARD, PORT AILERON, ASSEMBLY, INBOARD, STARBOARD				1 1	— —	A A	49/1 49/2
(Complementary parts, e.g. inter-component attachments listed at the end of this assembly will not be supplied with the assembly spare and must be demanded separately when required)									
Spares for :—									
1931	7G2896	Bolt , hex.hd, 2 BA x 1.07" long attachment of trimmer control rod to lever				1	S2	C	49/3
13014	1SS3261	Bolt , flat hd, 4 BA x 1/4" long for mod., and serial plates				4	S1	C	49/4
13495	8F5370	Bolt , hex.hd, 2 BA x .5" long, attachment of ball end support				2	S1	M C	49/5
13828	9F5370	Bolt , hex.hd, 2 BA x .6" long attachment of ball end support				1	S1	M/C	49/6
13123	34F5628	Deflector , aileron, inboard between ribs 1-4				6	L72		49/7
13911	17SS3221	Door , inspection aileron hinge between ribs 4-5				1	L72	C	49/8
	20SS3221	Door , inspection				5	L72	C	49/9
DOOR, INSPECTION BETWEEN RIBS 11-12 (F5627)									
Spares for :—									
3639	3F5627	Panel , door access				1	L72	C	49/10
13003	4SS3158	Screw , csk.hd, 2 BA x .5" long for access panel				20	S1	C	49/11
GEAR, TRIMMER OPERATING, PORT AND STARBOARD (17&18F5370) (See Controls—Flying Trimmer)									
	1F5362	NOSE, AILERON, PORT GROUP ...				1	—		49/12
	2F5362	NOSE, AILERON, STARBOARD, GROUP				1	—		49/13
Spares for :—									
27S/146	CA7	Bearing , ball, inner hinge housing ...				1	—	B	49/14
13002	68F3762	Bolt , hex.hd, 1/4" BSF x 8" long attachment of ball race housing				8	S1	C	49/15
3640	52F5362	Bolt , hex.hd, 1/4" BSF attachment of forging to spare				2	S2 or S11	C	49/16
13829	1F5399	Forging , nose port				1	L40 or DTD410	M/C	49/17
13830	2F5399	Forging , nose starboard				1	L40 or DTD410	M/C	49/18
3641	13F5360	HOUSING, HINGE DATUM, GROUP				1	—	C	49/19
Consisting of :—									
27S/3146	CA7	Ball , race				1	—	B	
	13aF5360	Housing				1	L40		
	16F5360	Plate , end				1	L72		
28Q/12343	AS2230/314	Rivets , csk.hd, 3/32" dia. x 7/8" long ...				1	DTD327	C	

MAIN PLANES
AILERON (INBOARD)

Ref. No.	Part No.	Description				No. off	Matl. Spec.	Cl. of	Plate and Illust'n No.
		1	2	3	4			St. M.R.	
		NOSE, AILERON, PORT AND STARBOARD, GROUP (1&2F5362) (Cont'd)							
2612 13530	12F5360	Housing, hinge inner				1	L40		49/20
	61F5365	Screws, csk. hd, 2 BA for mass balance weights				22	—	C	49/21
	SS3830	Screw, raised hd, 2 BA x .3125" long skin covering for forging				4	S1	C	49/22
	51F5362	Washer, for balance weight screws ...				22	S3		49/23
	7F5361	Weight, mass balance				1	Lead		49/24
	9F5361	Weight, mass balance				1	Lead		49/25
	14F5361	Weight, mass balance				2	Lead		49/26
	13043 13044 554	1SS3259	Plate, modification record				1	—	C
	1SS3260	Plate, serial No.				1	—	C	49/28
	1F6370	Shield, ice, for trimmer control rod ...				1	DTD213	M/C	49/29
	48F5628	Strut, bracing, inboard, port				1	DTD310		
	54F5628	Strut, bracing, inboard, port				1	DTD310		
	44F5628	Strut, bracing, inboard, starboard				1	DTD310		
	46F5628	Strut, bracing, inboard, starboard				1	DTD310		
3643 3644	1F6897	TAB, TRIMMER, PORT, GROUP... ...				1	—	C	49/30
	2F6897	TAB, TRIMMER, STARBOARD, GROUP ...				1	—	C	49/31
		Spares for :—							
3350	28F6897	HINGE, TAB, PORT, GROUP ...				1	—	C	49/32
		Consisting of :—							
	28aF6897	Hinge, half				1	L72		49/33
	17bF6897	Hinge, half				1	L72		49/34
	21cF5369	Pin, hinge				1	S1		
3351	29F6897	HINGE, TAB, STARBOARD, GROUP ...				1	—	C	49/35
		Consisting of :—							
	29aF6897	Hinge, half				1	L72		49/36
	18bF6897	Hinge, half				1	L72		49/37
	21cF5369	Pin, hinge				1	S1		
3645	24F6897	LEVER, OPERATING, TAB, PORT, GROUP ...				1	—	C	49/38
3646	25F6897	LEVER, OPERATING, TAB, STARBOARD, GROUP ...				1	—	C	49/39

SHACKLETON Mk 2

**MAIN PLANES
AILERONS (INBOARD)**

Ref. No.	Part No.	Description				No. off	Matl. Spec.	Cl. of St.	Plate and Illust'n No.
		1	2	3	4			M.R.	
COMPLEMENTARY ITEMS									
ATTACHMENT FITTINGS FOR JOINTINGS INBOARD AND OUTBOARD AILERONS									
13511	38F5360	Bolt , hex.hd, $\frac{3}{8}$ " BSF for attachment of fulcrum forging to outboard aileron				4	S2	C	49/40
13512	39F5360	Bolt , hex.hd, $\frac{3}{8}$ " BSF for attachment of fulcrum forging to inboard aileron				4	S2	C	49/41
28D/9853	AS1885/1/2 C	Bolt , mush.hd, 2 BA x .45" for attachment of covers at fulcrum forging				25	MS	C	49/42
13515	1F5695	COVER, DETACHABLE, AT AILERON CONNECTIONS, PORT, GROUP				1	—	M/C	49/43
13516	2F5695	COVER, DETACHABLE, AT AILERON CONNECTIONS, STARBOARD, GROUP				1	—	M/C	49/44
13471	1F5361	Fulcrum , forging, for aileron connections, port				1	L40 or DTD410	M/C	49/45
13472	2F5361	Fulcrum , forging for aileron connections, starboard				1	L40 or DTD410	M/C	49/46
28M/772	A16Y.JS	Nut , slotted, $\frac{3}{8}$ " BSF for bolts attaching fulcrum forging to inboard and outboard ailerons				8	—	C	49/47
28P/5032	AGS784/3	Pin , split, $\frac{1}{16}$ " dia. x 1" long, for bolts attaching fulcrum forging to inboard and outboard ailerons				8	Nickel Alloy	C	49/48
13510	37F5360	Plate , flexible for aileron connection ...				8	Spring Steel	C	49/49
	7F5402	Plate , cover, for detachable cover at aileron connections				1	DTD610		49/50
13513	40F5360	Washer , packing, between fulcrum forging at nose end				8	S3	C	49/51
13514	41F5360	Washer , for bolts at aileron connections ...				8	Lamimum Shim Brass	C	49/52
ATTACHMENT FITTINGS INBOARD AILERON TO TRAILING EDGE (See Complementary Items— "Trailing Edge Outboard")									

MAIN PLANES
AILERONS (INBOARD)

Ref. No.	Part No.	Description				No. off	Matl. Spec.	Cl. of St.	Plate and Illust'n No.
		1	2	3	4			M.R.	
SUMMARY OF STOCK ITEMS USED ON INBOARD AILERON ASSEMBLY									
28D/12947	AS1246/1/2B	Bolt , rd.hd, 4 BA x .5" long	20	—	C	
28D/8341	AS1248/1C	Bolt , mush.hd, 2 BA x .5" long	40	—	C	
28M/10287	AGS2001/B/1	Nut , stiff, 2 BA	20	—	C	
28M/10288	AGS2001/C/1	Nut , stiff, 2 BA	43	—	C	
28W/12305	SP/13B	Washer , 4 BA	20	—	C	
28W/12245	SP/10C	Washer , 2 BA	40	—	C	

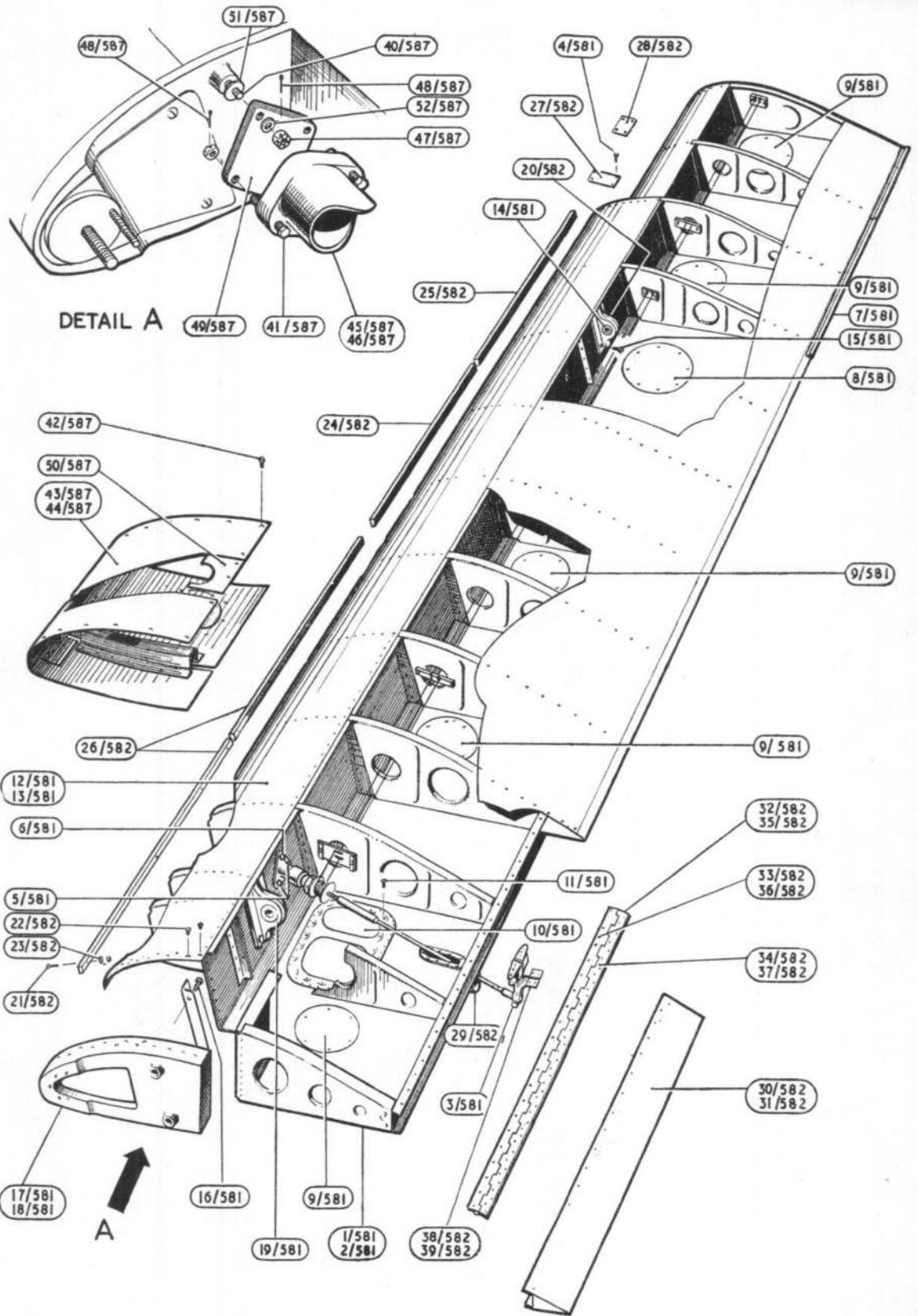

AILERONS — INBOARD

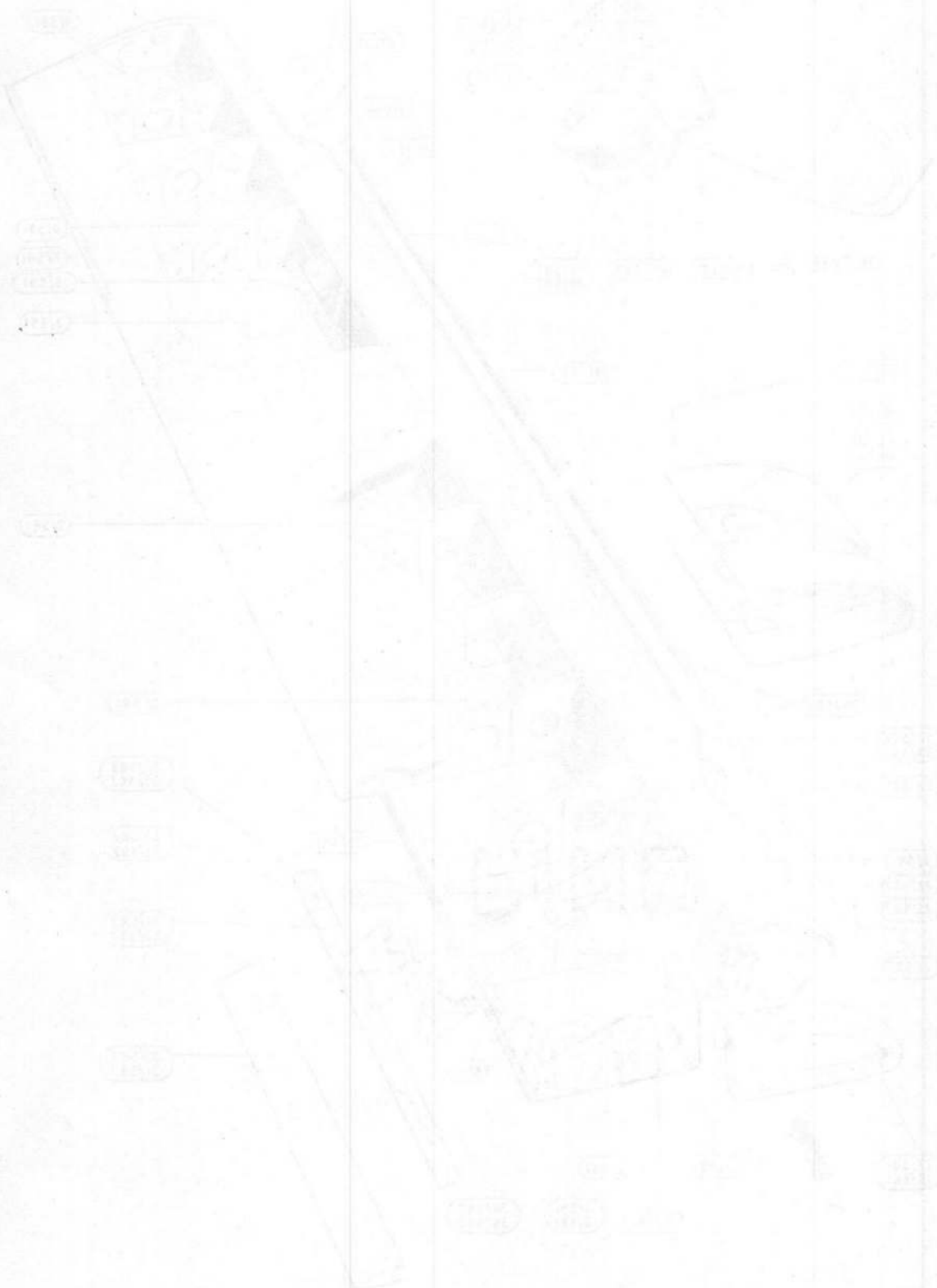

ALERONS - INBOARD

SHACKLETON Mk. 2

MAIN PLANES
AILERON (OUTBOARD)

Ref. No.	Part No.	Description				No. off	Matl. Spec.	Cl. of St.	Plate and Illust'n No.
		1	2	3	4			M.R.	
75	111F5628	AILERON, ASSEMBLY, OUTBOARD, PORT				1	—	A	50/1
76	113F5628	AILERON, ASSEMBLY, OUTBOARD, STARBOARD				1	—	A	50/2
		(Complementary parts, e.g. inter-components are listed at the end of the "MAIN PLANE OUTER ASSEMBLY AND AILERON INNER ASSEMBLY")							
		Spares for :—							
	3SS3261	Bolt , flat hd, 4 BA x 1/2" long for mod. plate ...				4	S1	C	50/3
13123	17SS3221	Door , inspection for trimmer tab control rod between ribs 16-17 and aileron hinge between ribs 25-26				2	L72	C	50/4
13911	20SS3221	Door , inspection between ribs 15-16 ...				1	L72	C	50/5
	1F5365	NOSE, AILERON, PORT, GROUP ...				1	—		50/6
	2F5365	NOSE, AILERON, STARBOARD, GROUP				1	—		50/7
		Spares for :—							
2A/9500467	CA3	Bearing , ball outer hinge, housing ...				1	—	B	50/8
13002	68F3762	Bolt , hex.hd, 1/4" BSF x .8" long for ballrace housing				4	A1	C	50/9
3640	52F5362	Bolt , hex.hd, 1/4" BSF attachment of forging to spar				2	S2	C	50/10
6945	52F5365	Bolt , 2 BA x 1 1/8" long attachment of hinge housing				4	S2 or S11		50/11
26EA/31870	1F5408	Forging , in nose port ...				1	L40 or DTD410	M/C	50/12
13831	2F5408	Forging , in nose starboard ...				1	L40 or DTD410	M/C	50/13
6667	14F5360	HOUSING, HINGE DATUM, GROUP				1	—	B	50/14
		Consisting of :—							
2A/9500470	CA7	Bearing , ball ...				1	—	B	
	14aF5360	Housing ...				1	L40		
	16F5360	Plate ...				1	L72		
28Q/12343	AS2230/314	Rivet , csk.hd, 3/32" dia. x 7/8" long ...				4	—	C	
6646	15F5360	Housing , hinge outer ...				1	L40		50/15
2613	60F5365	Screw , csk.hd, 2 BA x .19" long for mass balance weights				23	S1	C	50/16
13530	SS3830	Screw , raised hd, 2 BA x .3125" long for skin covering at forging				4	S1	C	50/17
3642	51F5362	Washer , for balance weight screws ...				23	S3	C	50/18
	11F5631	Weight , mass balance, ...				2	Lead		50/19
	12F5631	Weight , mass balance, ...				1	Lead		50/20
	15F5631	Weight , mass balance, port ...				1	Lead		50/21
	16F5631	Weight , mass balance, starboard ...				1	Lead		50/22
13043	1SS3259	Plate , modification record ...				1	—	C	50/23
13044	1SS/3260	Plate , Serial No. ...				1	—	C	50/24

MAIN PLANES
AILERON (OUTBOARD)

Ref. No.	Part No.	Description				No. off	Matl. Spec.	Cl. of St.	Plate and Illust'n No.
		1	2	3	4			M.R.	
ROD AND LEVER CONTROL TRIMMER BALANCE TAB (2F5429)									
Consisting of :—									
28D/9570	AS1885/9C	Bolt , mush.hd, 2 BA x 1.30" long attachment of aileron lever to tab				1	MS	C	50/25
28D/7002428	A25/6C	Bolt , hex.hd, 2 BA x 1.05" long attachment of control rod to lever				1	—	C	50/26
28D/9133011	A25/2CR	Bolt , 2 BA x .65" long attachment of lever to tab				1	—	C	50/27
13052	7G1094	Bush , for bolt control rod to lever balance tab				2	S1	C	50/28
LEVER BALANCE TAB (10F5429)									
Consisting of :—									
28D/7002428	10aF5429	Block , fairing				1	BALSA	C	50/29
	A25/6C	Bolt , hex.hd, 2 BA x 1.05" long				1	—	C	50/30
	2aF4682	Lever				1	S3	C	50/30
28M/10288	AGS2001/C1	Nut , stiff, 2 BA				1	—	C	50/31
	2cF4682	Piece , distance				1	L1	C	50/31
28S/2470	AGS251/20	Woodscrew , No. 4, csk.hd, ½" long				7	—	C	
28M/767	A16Y/CS	Nut , slotted, 2 BA				1	—	C	
28M/13121	A27/CS	Nut , slotted, 2 BA				2	—	C	
28P/5032	AGS784/3	Pin , split, ⅛" x 1" long				1	—	C	
28P/1202462	SP9/C4	Pin , split, ⅛" x ½" long				2	—	C	
2673	5F5490	ROD, CONTROL, TRIMMER, BALANCE TAB, GROUP				1	—	A	50/32
Consisting of :—									
13566	4F5490	EYEBOLT, GROUP				1	—	B	50/33
Consisting of :—									
2A/9500462	CAO	Bearing , ball				1	—	B	
	4aF5490	Plug , for ball bearing				1	L40		
28M/749	A16Y/JC	Nut , slotted, ⅜" BSF				1	—		
13346	24G1248	PLUG, GROUP					—	M/C	50/34
Consisting of :—									
2A/9500462	CAO	Bearing , ball				1	—	B	
	24aG1248	Plug , for ball bearing				1	L40		
28Q/6670	AS2227/412	Rivet , snap hd, ⅛" dia. x ¾" long				4	—	C	
28Q/11810	AS2227/413	Rivet , snap hd, ⅛" dia. x ⅜" long				1	—	C	
5809	1G1796	Shield , ice				1	—		50/35
	3F5490	Sleeve				1	S1		50/36
	2F5490	Tube				1	T4		50/37
28W/8516	AS470/C	Washer , 2 BA for attaching lever balance tab				1	—	C	
13361	P/SS157	Washer , 2 BA taper for bolts, attaching lever to balance trimmer tab				2	S1	C	50/38
28W/3071	AGS160/C	Washer , 2 BA				2	—	C	
7992	35F5628	Strut , bracing, outboard, port				1	DTD310	C	
7993	37F5628	Strut , bracing, outboard, port				1	DTD310	C	
6913	43F5628	Strut , bracing, outboard, starboard				1	DTD310	C	
	45F5628	Strut , bracing, outboard, starboard				1	DTD310	C	

SHACKLETON Mk. 2

MAIN PLANES
AILERON (OUTBOARD)

Ref. No.	Part No.	Description				No. off	Matl. Spec.	Cl. of St.	Plate and Illust'n No.
		1	2	3	4			M.R.	
2674	1F6898	TAB, BALANCE TRIMMER, PORT, GROUP				1	—	C	50/39
2675	2F6898	TAB, BALANCE, TRIMMER, STARBOARD, GROUP				1	—	C	50/40
	5F6898	HINGE, TAB PORT, GROUP ...				1	—		50/41
	5aF6898	Hinge, half				1	DTD390		50/42
	17bF5400	Hinge, half				1	DTD610		50/43
	17cF5400	Pin, hinge				1	DTD390		50/43
	6F6898	HINGE, TAB, STARBOARD, GROUP				1	—		50/44
	6aF6898	Hinge, half				1	DTD390		50/45
	18bF5400	Hinge, half				1	DTD610		50/46
	17cF5400	Pin, hinge				1	DTD390		50/46
							S3		

MAIN PLANES
AILERON (OUTBOARD)

Ref. No.	Part No.	Description				No. off	Matl. Spec.	Cl. of St.	Plate and Illust'n No.
		1	2	3	4			M.R.	
SUMMARY OF STOCK ITEMS USED ON OUTBOARD AILERON ASSEMBLY									
28D/8341	AS1248/1C	Bolt , mush.hd, 2 BA x .5" long	40	—	C	
28M/10288	AGS2001/C/1	Nut , stiff, 2 BA	46	—	C	
28W/3071	AGS160/C	Washer , 2 BA	10	—	C	
28W/12245	SP/10C	Washer , 2 BA	40	—	C	

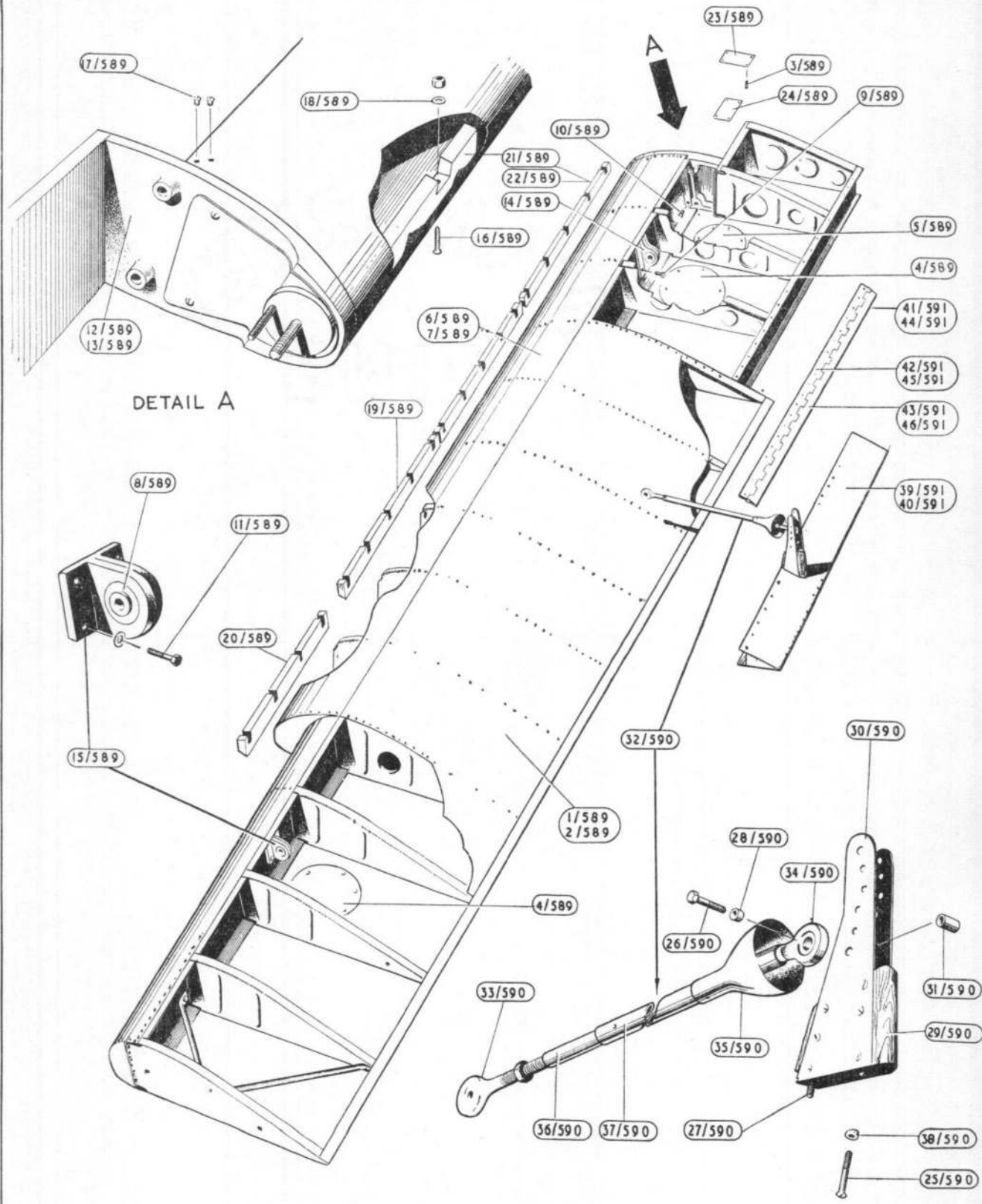

DETAIL A

AILERONS — OUTBOARD

TOP SECRET

[The following text is extremely faint and largely illegible due to low contrast and bleed-through. It appears to be a multi-paragraph document, possibly a report or a letter, with several lines of text in each section. The text is mirrored across the page, suggesting it is bleed-through from the reverse side.]



MAIN PLANES
TRAILING EDGE (INBOARD)

Ref. No.	Part No.	Description				No. off	Matl. Spec.	Cl. of St.	Plate and Illust'n No.
		1	2	3	4			M.R.	
4035	21F6418	EDGE, TRAILING, ASSEMBLY, INBOARD, INCLUDING DUMMY FLAP (2F6509) BUT LESS MOVEABLE FLAP, PORT				1	—	A	51/1
4036	21F6419	EDGE, TRAILING, ASSEMBLY, INBOARD, INCLUDING DUMMY FLAP (1F6509) BUT LESS MOVEABLE FLAP, STARBOARD (Pre Mod. 579)				1	—	A	51/2
4045	31F6419	EDGE, TRAILING, ASSEMBLY, INBOARD, INCLUDING DUMMY FLAP (1F5609) BUT LESS MOVEABLE FLAP, STARBOARD (Mod. 579) (Complementary parts, e.g. inter-component attachments listed at the end of this assembly will not be supplied with the assembly spare and must be demanded separately)				1	—	A	51/2
13035	6F3678	Bearing, for flap operating tube on ribs Nos. 24, 25, 27, 28, 29, 31, 31				7	TUFNOL	C	51/3
13014	1SS3261	Bolt, flat hd, 4 BA x 1/4" long for mod. and serial plates				4	S1	C	
28D/8484	AS1885/1C	Bolt, mush.hd, 2 BA x .5" long for attachment of panels				39P 33S	S1	C	
28D/8485	AS1885/2C	Bolt, mush.hd, 2 BA x .6" long for attachment of panels				26	S1	C	
13371	2F4716	Buffer, 3/8" dia. x 2 1/2" long				6	Rubber	C	51/4
4439	1F7767	DOOR, HINGED, ACCESS TO FUEL SYSTEM, PORT, GROUP				1	—	A	51/5
4440	1F7768	DOOR, HINGED, ACCESS TO FUEL SYSTEM, STARBOARD, GROUP				1	—	A	51/6
13123	17SS3221	Door, inspection				1	L72	C	
28FP/204	AJ6 1/2-40	Fastener				11	—	C	
28FP/	GA6 1/2-375	Grommet				5	—	C	
	16F7767	Hinge, (AS1858/41 1/2") port, door				1	DTD213		
	13F7768	Hinge, (AS1858/42 1/2") stbd., door				1	DTD213		
	2F6509	FLAP, DUMMY, PORT, GROUP				1	—		51/7
	1F6509	FLAP, DUMMY, STARBOARD, GROUP FUEL SYSTEM (7&8P2895) (See Services—Fuel Installation)				1	—		51/8
		INDICATOR, FLAP, TRANSMITTER, PORT (F6448) Spares for :—							
13744	8F4110	Bracket, transmitter				1	L72	C	51/9
13364	13F4110	Fork, end, fitting				1	—	C	51/10
5132	2F6652	Lever				1	L40	C	51/11
13366	11F4110	Screw, adjusting				1	S1	C	51/12
	3F6448	Stay, bracket				1	—		51/13
6A/2133	—	Transmitter, flap				1	—	A	51/14
539	1F6209	LID, DINGHY STOWAGE, GROUP				1	—	M/C	51/15
		Spares for:—							
2934	7F6111	Frame, for window				1	L72	C	
5303	1F6162	PIN, ADJUSTABLE, COMPLETE				1	—	C	
		Spares for :—							
	6F6162	Pin, 1/2" dia. x 1 1/2" long				1	S80		
2935	6F6111	Seal, for window				1	Langite	C	51/16
2936	12F6111	Window				1	DTD339A	C	51/17

MAIN PLANES
TRAILING EDGE (INBOARD)

Ref. No.	Part No.	Description	No. off	Matl. Spec.	Cl. of St.	Plate and Illust'n No.	
					M.R.		
		1	2	3	4		
13028	1F3911	LINK, FLAP, OPERATING, GROUP (Pre-Mod. 966)	3	—	C	51/18	
		Consisting of:—					
13036	2F3911	Body, link	1	L40	C	51/19	
13037	4F3911	Bolt, eye	1	S1	C	51/20	
13038	3F3911	Bush	2	B6	C	51/21	
13039	6F3911	Collar	1	L1	C	51/22	
28N/9796	AGS554	Nipple, grease (Tecalemit T.A.T. 6878)	1	—	C		
13040	5F3911	Pin, $\frac{5}{8}$ " dia. x $1\frac{3}{8}$ " long	1	S2	C	51/23	
13041	8F3911	Pin, $\frac{1}{8}$ " dia. x $2\frac{3}{16}$ " long	1	S2	C	51/24	
28P/5044	AGS784/20	Pin, split, $\frac{1}{8}$ " x $1\frac{1}{4}$ " long	1	—	C		
13042	7F3911	Screw, grub	1	S2	C	51/25	
	1F11674	LINK, FLAP, OPERATING, GROUP (Mod. 966)	3	—	C	51/18	
		Consisting of:—					
	2F11674	Body, link	1	L77	C	51/19	
	3F11674	Bolt, eye	1	S95	C	51/20	
13038	3F3911	Bush	2	BS249	C	51/21	
13039	6F3911	Collar	1	DTD410	C	51/22	
	NB5951	Nipple, grease (Tecalemit Ltd.)	1	—	C		
13040	5F3911	Pin, $\frac{5}{8}$ " o/d x $1\frac{3}{8}$ " long	1	S94	C	51/23	
13041	8F3911	Pin, $\frac{1}{8}$ " o/d x $2\frac{3}{16}$ " long	1	—	C		
	SP9/G10	Pin, split	1	—	C		
13042	7F/3911	Screw, grub	1	S3	C	51/25	
	9F6800	PANEL, UNDRILLED, OUTBOARD, PORT, GROUP (Pre-Mod. 712)	1	—		51/26	
	12F6800	PANEL, UNDRILLED, OUTBOARD, PORT, GROUP (Mod. 712)	1	—			
		Spares for:—					
28D/8484	AS1885/1C	Bolt, mush. hd., 2 BA x .5" long	28	S1	C		
	3F6800	Door, inspection	1	L72			
13124	30SS3221	Plate, inspection door	1	L72	C		
4583	1F8396	PANEL, UNDRILLED, DETACHABLE, INBOARD, PORT, GROUP	1	—	C	51/27	
		Spares for:—					
13173	4F3999	Door, inspection, access to aileron controls, complete with labels	1	—	C		
13003	4SS3158	Screws, csk. hd., 2 BA x $\frac{1}{2}$ " long	6	—	C		
4584	1F8397	Panel, undrilled, centre, port	1	DTD546 & L72	C		
	10F6416	PANEL, UNDRILLED, ASSEMBLY, OUTBOARD, STARBOARD, GROUP (Pre-Mod. 579) (Pre-Mod. 712)	1	—		51/28	
	57F6416	PANEL, UNDRILLED, OUTBOARD, STARBOARD, GROUP (Mod. 712)	1	—			
		Spares for:—					
28D/8484	AS1885/1C	Bolt, mush. hd., 2 BA x .5" long	42	S1	C		
	2F6416	Door, inspection	1	L72			
5597	1F9717	PANEL, UNDRILLED, ASSEMBLY, INBOARD, STARBOARD, GROUP (Mod. 579)					
		Spares for:—					
28D/8341	AS1248/1C	Bolt, mush. hd., 2 BA x .5" long	42	S1	C		
	2F6416	Door, inspection	1	L72			

MAIN PLANES
TRAILING EDGE (INBOARD)

Ref. No.	Part No.	Description				No. off	Matl. Spec.	Cl. of	Plate and Illust'n No.
		1	2	3	4			St. M.R.	
4585	1F8398	PANEL, UNDRILLED, DETACHABLE, INBOARD, STARBOARD, GROUP				1	—	C	51/29
		Spares for :—							
13173	4F3999	Door , inspection, access to aileron control, complete with labels				1	—	C	
13003	4SS3158	Screws , csk. hd., 2 BA x 1/8" long				6	S1	C	51/30
		Panel , undrilled, centre, starboard				1	DTD5464 & L72	C	
	45Z6830	Pipe , de-icing, 3/8" o/d x 22G, port				1	DTD323A		
	46Z6830	Pipe , de-icing, 3/8" o/d x 22G, port				1	DTD323A		
13043	SS3259	Plate , modification record				1	—	C	
13044	SS3260	Plate , serial No.				1	—	C	
		RELEASE, MECHANICAL GAS OPERATED DINGHY STOWAGE (F7613) (See Equipment—Dinghy and Parachute)							
	1F6164	PANEL, GROUP				1	—	C	
2269	15F6112	Pin				1	S80	C	
3401	3F7613	Plate , guide				1	L72	C	
3402	37F6112	Plate , guide				1	L72	C	
2270	8F6112	Plate , base				1	L72	C	
2411	26F6112	ROD, CONTROL (SHORT), GROUP				1	—	C	
		Consisting of :—							
	26aF6112	Fork , end fitting				1	S80		
	24aF6112	Fork , end fitting				1	S80		
28Q/1969	AS455/308	Rivet , snap hd., 3/32" dia. x 1/2" long				4	—	C	
	26bF6112	Tube , control				1	T35		
2271	39F6112	ROD, CONTROL (LONG), GROUP				1	—	C	
		Consisting of :—							
	24aF6112	Fork , end fitting				1	S80		
	25aF6112	Fork , end fitting				1	S80		
28Q/1969	AS455/308	Rivet , snap hd., 3/32" x 1/2" long				2	—	C	
	39aF6112	Tube , control				1	T35		
3386	6F6112	Roller , 3/4" dia. x 7/16" long				2	S80	C	
3387	29F6112	Roller , 1/2" dia. x 1/2" long				2	S80	C	
1376	4F7613	Spigot , 1/8" dia. x 1" long				1	S80	C	
3388	8F7613	Spigot , 3/16" dia. x 1" long				1	S80	C	
2469	11F6112	Spring				2	—	C	
3389	31F6112	Spring				1	—	C	
3390	9F6112	Stop , 5/16" dia. x 1 3/8" long				2	S80	C	
3391	10F6112	Stop , 5/16" dia. x 1" long				2	S80	C	
3392	43F6112	Stud , 9/16" x 1 1/16" x 3/4"				1	S80	C	
28Q/9374	AGS2050/BS 630	Rivet , pop. dome hd., 3/16" for assembly panels				QR	—	C	
28Q/9517	AGS2050/BS 636	Rivet , pop. dome hd., 3/16" for assembly panels				QR	—	C	
794	1R2759	ROD, AILERON CONTROL, GROUP (See Flying Controls)				1	—	C	51/32
540	6F6207	Seal , for dinghy lid, front, 2' 7-79"				1	LINATEX	C	51/33
541	7F6207	Seal , for dinghy lid, rear, 2' 7-54"				1	LINATEX	C	51/34
3492	3F6414	STRIP, ATTACHMENT, COMPLETE WITH FLOATING STRIP NUT, PANEL, OUTBOARD, PORT, GROUP				1	—	C	51/35
5C/2866	—	Suppressor , type "B"				1	—	C	

MAIN PLANES
TRAILING EDGE (INBOARD)

Ref. No.	Part No.	Description				No. off	Matl. Spec.	Cl. of St.	Plate and Illust'n No.
		1	2	3	4			M.R.	
4831	1Z7108	TANK, FOR GALLEY WASTE, BETWEEN RIBS No. 30-31, PORT, GROUP				1	—	A	
		Spares for :—							
	2Z7108	Body, tank	1	—		
	14Z7108	Cable, steel, 3 cwt. x 16" long	1	—		
4832	8Z7108	Cap, filler	1	L45	C	
4833	13Z7108	FILTER, GROUP				1	—	C	
	10Z7108	Flanged, screwed	1	L45		
	18Z7108	Gasket, at filler cap	1	Neoprene		
	16Z7108	Gasket, at screwed flange	1	Neoprene		
	11Z7108	Spring	1	Spring Steel		
	15Z7108	Tube, for retaining wire	1	T17		
2412	1F8199	TUBE, FLAP, OPERATING PORT, GROUP				1	—	C	51/36
2413	1F8200	TUBE, FLAP, OPERATING, STARBOARD, GROUP				1	—	C	51/37
		Spares for :—							
13030	4F3913	Cap	2	L40	C	51/38
13031	2F3913	Circlip, Seegar internal type "16"	7P	—	C	51/39
						5S	—		
13594	11F3913	Clip, spring	2	Steel	C	51/40
13595	6F3913	Locknut	1	S1	C	51/41
13034	10F3913	Nut, cap	2	L40	C	51/42
13033	5F3913	Plug, ball end	1	DTD126	C	51/43
13176	3F4291	Trunnion, body	1	L40	C	51/44
13895	16F3588	Washer, for bolts connecting dummy flaps...				82P	L3	C	
						81S			

PAGE 599 TO 602 NOT ISSUED



MAIN PLANES
TRAILING EDGE (INBOARD)

Ref. No.	Part No.	Description				No. off	Matl. Spec.	Cl. of	Plate and Illust'n No.
		1	2	3	4			St. M.R.	
		COMPLEMENTARY ITEMS ATTACHMENT FITTINGS, TRAILING EDGE TO FUSELAGE CENTRE PORTION							
28M/10292	AGS2001/J/1	Consisting of :— Nut, stiff, $\frac{3}{8}$ " BSF				95	—	C	1/40
		ATTACHMENT, FITTINGS, AILERON PUSH PULL CONTROL ROD, TO INTERMEDIATE LEVER AT FUSELAGE CENTRE PORTION REAR SPAR (R2499)							
		Consisting of :—							
13263	5R2255	Bolt, hex.hd, $\frac{3}{8}$ " BSF x $2\frac{9}{16}$ " long ...				1	S1	C	
13402	4R2255	Bush, CT24 $\frac{1}{2}$ " i/d x 1" long ...				2	Oilite	C	
28M/772	A16Y/JS	Nut, slotted $\frac{3}{8}$ " BSF				1	—	C	
28P/5032	AGS784/3	Pin, split, $\frac{1}{16}$ " x 1" long				1	Nickel Alloy MS	C	
28W/3074	AGS160/F	Washer, for $\frac{1}{4}$ " bolts				1	MS	C	
		ATTACHMENT FITTINGS AILERON PUSH PULL CONTROL ROD INNER AT RIB 31 (R2756)							1/41
		Consisting of :—							
13362	6dR2226	Bolt, $\frac{1}{4}$ " BSF				1	S1	C	
28M/768	A16Y/ES	Nut, slotted, $\frac{1}{4}$ " BSF				1	—	C	
28P/5032	AGS874/3	Pin, split, $\frac{1}{16}$ " dia. x 1" long				1	Nickel Alloy MS	C	
28W/3072	AGS160/D	Washer, for $\frac{1}{4}$ " bolts				1	MS	C	
		ATTACHMENT FITTINGS, FLAP ATTACHMENT TO INBOARD TRAILING EDGE (F6418 & F6419)							1/42
		Consisting of :—							
28D/9140203	AS1246/3C	Bolt, 2 BA rd.hd, x .7" long				2	—	C	
28D/11971	AS1246/4C	Bolt, 2 BA rd.hd, x .8" long				45P	—	C	
13895	16F3588	Washer				44S 47P 46S	L3 L3	C C	
		ATTACHMENT FITTINGS, COVER JOINT INBOARD TO OUTBOARD TRAILING EDGE AND BODY, PORT AND STARBOARD (C2109)							
2676	1F7477	COVER, JOINT, TOP, INBOARD TO OUTBOARD TRAILING EDGE, PORT, GROUP				1	—	C	1/43
		Spares for :—							
26EA/16440	3F4658	DOOR, ACCESS, TO AILERON CONTROL ADJUSTMENT, GROUP				1	—	C	1/44
13762	5F3975	FAIRING, TRAILING EDGE TIP, GROUP				1	—	C	1/45
2677	2F7477	COVER, JOINT, TOP INBOARD TO OUTBOARD TRAILING EDGE, STARBOARD, GROUP				1	—	C	1/46
		Spares for :—							
26EA/16440	3F4658	DOOR, ACCESS, TO AILERON CONTROL ADJUSTMENT, GROUP				1	—	C	
13379	6F3975	FAIRING, TRAILING EDGE TIP, GROUP				1	—	C	1/47

MAIN PLANES
TRAILING EDGE (INBOARD)

Ref. No.	Part No.	Description				No. off	Matl. Spec.	Cl. of St.	Plate and Illust'n No.
		1	2	3	4			M.R.	
ATTACHMENT FITTINGS, COVER JOINT, INBOARD TO OUTBOARD TRAILING EDGE AND BODY, PORT AND STARBOARD (C2109) (Cont'd)									
2678	3F7477	COVER, JOINT, BOTTOM INBOARD TO OUTBOARD TRAILING EDGE, PORT, GROUP				1	—	C	1/48
2679	4F7477	COVER, JOINT, BOTTOM INBOARD TO OUTBOARD TRAILING EDGE, STARBOARD, GROUP				1	—	C	1/49
14757	1F3970	COVER, JOINT, TOP, BODY TO INBOARD TRAILING EDGE, PORT, GROUP				1	—	C	
Consisting of:—									
2680	1aF3970	Cover, top, port				1	L72	C	1/50
13415	5F3970	Fairing, trailing edge, tip				1	—	C	1/51
28Q/10412	AS2230/404	Rivets, csk.hd, 1/8" dia. x 1/4" long ...				4	—	C	
COVER, JOINT, BODY TO INBOARD TRAILING EDGE, STARBOARD (2F3970)									
Consisting of:—									
2681	2aF3970	Cover, top, starboard				1	L72	C	1/52
13416	6F3970	Fairing, trailing edge, tip				1	—	C	1/53
28Q/10412	AS2230/404	Rivet, csk.hd, 1/8" dia. x 1/4" long ...				4	—	C	
	3F3970	COVER, JOINT BOTTOM, BODY TO INBOARD TRAILING EDGE, PORT, GROUP				1	—		
Consisting of:—									
2682	3aF3970	Cover, bottom, port				1	L72	C	1/54
28M/9419400	CL/11	Nut, floating anchor				2	—	C	
28Q/10412	AS2230/404	Rivets, csk.hd, 1/8" dia. x 1/4" long ...				2	—	C	
14758	4F3970	COVER, JOINT BOTTOM, BODY TO INBOARD TRAILING EDGE, STARBOARD, GROUP				1	—	C	
Consisting of:—									
2683	4aF3970	Cover, bottom, starboard				1	L72	C	1/55
28M/9419400	CL/11	Nut, floating anchor				2	—	C	
28Q/10412	AS2230/404	Rivets, csk.hd, 1/8" dia. x 1/4" long ...				2	—	C	
13004	5SS3158	Screws, csk.hd, 120° x 5/8" long attachment at joint covers				QR	—	C	1/56
SUMMARY OF STOCK ITEMS USED ON INBOARD TRAILING EDGE ASSEMBLY									
28D/11971	AS1246/4C	Bolt, rd.hd, 2 BA x .80" long				79	—	C	
28D/8342	AS1248/2C	Bolt, mush.hd, 2 BA x .60" long				47	—	C	
28D/	AS1885/1C	Bolt, mush.hd, 2 BA x .50" long				72	—		
28D/	AS1885/2C	Bolt, mush.hd, 2 BA x .60" long				52	—		
28M/10330	AGS2002/E/1	Nut, stiff, 2 BA x 1/4" BSF				22	—	C	
28M/12079	AGS2004/C/1	Nut, csk.hd, 2 BA				18	—	C	
28M/9418918	AGS2012/C/11	Nut, Anchor, 2 BA				12	—	C	
28W/3071	AGS160/C	Washer, 2 BA				30	—	C	

MAIN PLANES TRAILING EDGE INBOARD

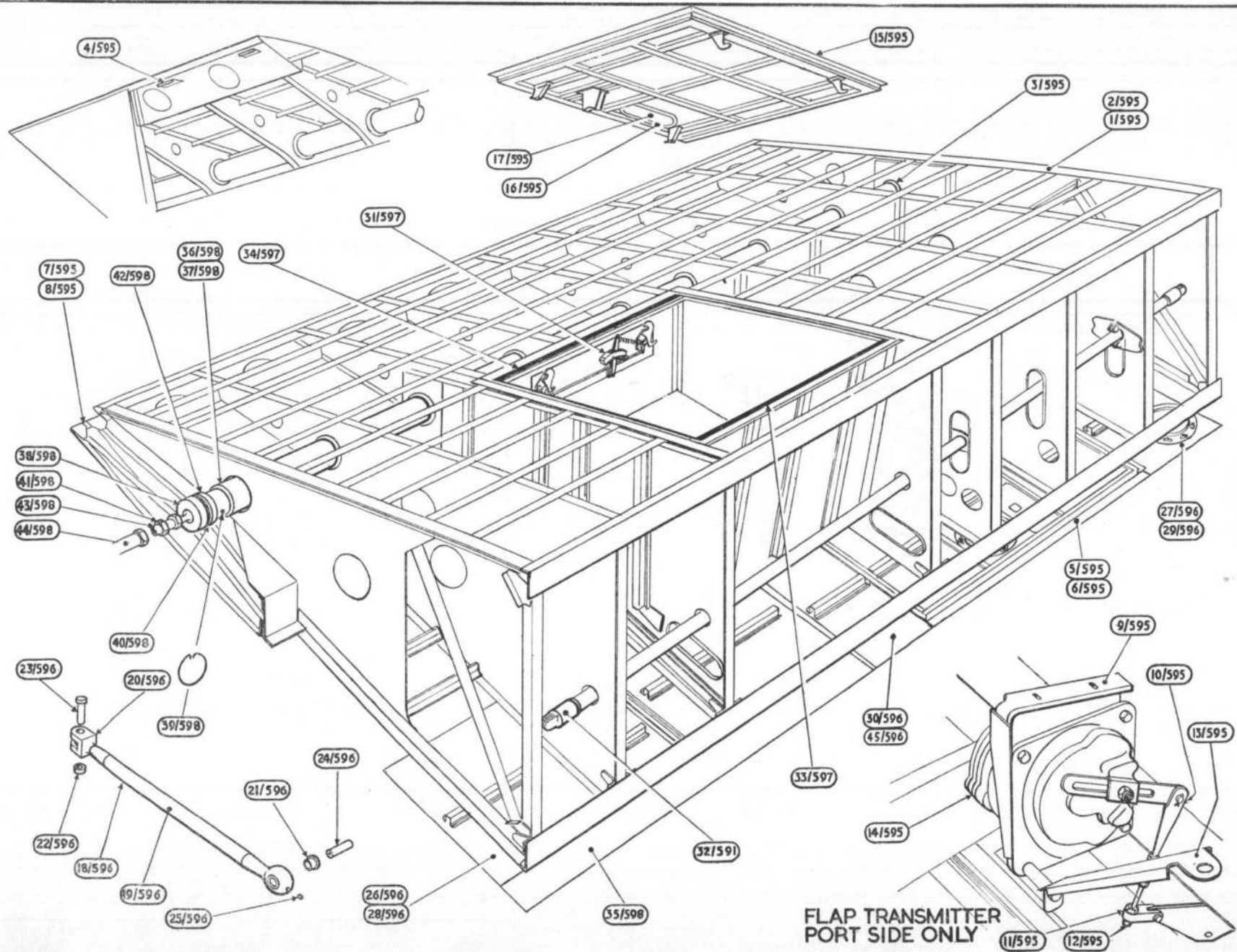

FLAP TRANSMITTER
PORT SIDE ONLY

RESTRICTED

RESTRICTED

PLATE NO. 51
ISSUE NO. 1



SHACKLETON Mk. 2

MAIN PLANES
TRAILING EDGE (OUTBOARD)

Ref. No.	Part No.	Description				No. off	Matl. Spec.	Cl. of St.	Plate and Illust'n No.
		1	2	3	4			M.R.	
4033	2F8327	EDGE, TRAILING ASSEMBLY OUTBOARD, LESS FLAP, PORT (Pre Mod. 579)				1	—	A	52/1
	21F8327	EDGE, TRAILING, ASSEMBLY, OUTBOARD, LESS FLAP, PORT (Mod. 579)				1	—		
4034	2F8328	EDGE, TRAILING ASSEMBLY OUTBOARD, LESS FLAP, STARBOARD (Pre Mod. 579)					—	A	52/2
4046	4F8328	EDGE, TRAILING, ASSEMBLY, OUTBOARD, LESS FLAP, STARBOARD (Mod. 579)				1	—	A	52/2
<p>(Complementary parts, e.g. inter-component attachments listed at the end of this assembly will not be supplied with the assembly and must be demanded separately when required).</p>									
<p style="text-align: center;">Spares for :—</p>									
13336	8F3588	Angle , for rib attachment, port				17	L72	C	52/3
13335	6F3589	Angle , for rib attachment, starboard... ..				17	L72	C	52/4
13174	9F4363	Bearing , for flap operating tube on ribs No. 2, 3, 4, 5, 6, 7, 8, 9, 10, 11				10	TUFNOL	C	52/5
13371	2F4716	Buffer , $\frac{3}{8}$ " dia. x $2\frac{1}{2}$ " long for flap				10	Rubber	C	52/6
CONTROLS AILERON (R2468)									
(See Controls—Flying)									
FUEL SYSTEM (9 & 10 P2895)									
(See Serials—Fuel Installation)									
HINGE, AILERON, WING RIB No. 14 (F5427)									
<p style="text-align: center;">Spares for :—</p>									
13481	3F5265	Arm , hinge				1	L40	C	52/7
13538	2SS3150	Bolt , instrument hd, $\frac{1}{4}$ " BSF x 1" long for attaching hinge arm				1	S2	C	52/8
13023	3SS3150	Bolt , instrument hd, $\frac{1}{4}$ " BSF x $\frac{1}{8}$ " long for attaching hinge arm				1	S2	C	52/9
13539	5SS3150	Bolt , instrument hd, $\frac{1}{4}$ " BSF x $1\frac{3}{4}$ " long for attaching hinge arm				1	S2	C	52/10
13540	6SS3150	Bolt , instrument hd, $\frac{1}{4}$ " BSF x $1\frac{1}{2}$ " long for attaching hinge arm				1	S2	C	52/11
13542	7SS3150	Bolt , instrument hd, $\frac{1}{4}$ " BSF x $\frac{5}{8}$ " long for attaching hinge arm				1	S2	C	52/12
5536	9F5485	Cover , for C.A.7 bearing (Mod. 578)				2	S84 or S3	C	
5123	2F5427	Packing , for hinge arms $\frac{1}{16}$ " thk. x 1" wide x 12" long				QR	Laminium	C	52/13
HINGE, AILERON, WING RIB No. 18 (F5428)									
<p style="text-align: center;">Spares for :—</p>									
13480	3F5269	Arm , hinge				1	L40	C	52/14
13023	3SS3150	Bolt , instrument hd, $\frac{1}{4}$ " BSF x $1\frac{1}{8}$ " long for attaching hinge arm				1	S2	C	52/9
13539	5SS3150	Bolt , instrument hd, $\frac{1}{4}$ " BSF x $1\frac{3}{8}$ " long for attaching hinge arm				1	S2	C	52/10

MAIN PLANES

TRAILING EDGE (OUTBOARD)

Ref. No.	Part No.	Description				No. off	Matl. Spec.	Cl. of St.	Plate and Illust'n No.
		1	2	3	4			M.R.	
		HINGE, AILERON, WING RIB No. 18 (F5428) (Cont'd)							
13024	8SS3150	Bolt, instrument hd, $\frac{1}{4}$ " BSF x $1\frac{3}{4}$ " long for attaching hinge arm				1	S2	C	52/15
13025	10SS3150	Bolt, instrument hd, $\frac{1}{4}$ " BSF x 2" long for attaching hinge arm				1	S2	C	52/16
13544	12SS3150	Bolt, instrument hd, $\frac{1}{4}$ " BSF x $2\frac{1}{4}$ " long, for attaching hinge arm				1	S2	C	52/17
	9F5485	Cover, for C.A.7 bearing (Mod. 578) ...				2	S84 or S3		
5124	5F5429	Packing, for hinge arms $\frac{1}{16}$ " thick x 1" wide x $11\frac{1}{2}$ " long				1	S2	C	52/18
13028	1F3911	LINK, FLAP OPERATING, GROUP ...				9	—	C	
		Spares for :—							
13036	2F3911	Body, link				1	L40	C	
13037	4F3911	Bolt, eye				1	S1	C	
13038	3F3911	Bush				2	B6	C	
13039	6F3911	Collar				1	L1	C	
28N/9796	AGS554	Nipple (Tecalmit TAT6878)				1	—	C	
13040	5F3911	Pin				1	S2	C	
13041	8F3911	Pin				1	S2	C	
13042	7F3911	Screw, grub				1	S1	C	
		(See page 596 for similar breakdown.)							
4342	1F8349	PANEL, UNDRILLED, ACCESS TO FUEL COCK, BETWEEN RIBS No. 6 & 7, PORT, GROUP				1	—	C	52/19
4343	2F8349	PANEL, UNDRILLED, ACCESS TO FUEL COCK, BETWEEN RIBS No. 6 & 7 STARBOARD, GROUP				1	—	C	52/20
4340	1F8355	PANEL, UNDRILLED, ACCESS TO FUEL COCK, BETWEEN RIBS No. 1 & 2, PORT, GROUP				1	—	C	52/21
4341	2F8355	PANEL, UNDRILLED ACCESS TO FUEL COCK, BETWEEN RIBS No. 1 & 2 STARBOARD, GROUP				1	—	C	52/22
4334	1F8356	PANEL, UNDRILLED, No. 1, BETWEEN RIBS No. 2 & 5, PORT, GROUP (Pre-Mod. 579)				1	—	C	52/23
5600	1F9716	PANEL, UNDRILLED, No. 1, BETWEEN RIBS, No. 2 & 5, PORT, GROUP (Mod. 579)				1	—	C	52/23
4335	2F8356	PANEL, UNDRILLED, No. 1, BETWEEN RIBS 2 & 5, STARBOARD, GROUP (Pre-Mod. 579)				1	—	C	52/24
5598	2F9716	PANEL, UNDRILLED, No. 1, BETWEEN RIBS 2 & 5, STARBOARD GROUP (Mod. 579)				1	—	C	52/24
4336	1F8353	PANEL, UNDRILLED, No. 2A, BETWEEN RIBS No. 5 & 6, PORT, GROUP (Pre-Mod. 579)				1	—	C	52/25
5601	1F9709	PANEL, UNDRILLED, No. 2A, BETWEEN RIBS No. 5 & 6, PORT, GROUP (Mod. 579)				1	—	C	52/25
4337	2F8353	PANEL, UNDRILLED, No. 2A, BETWEEN RIBS No. 5 & 6, STARBOARD, GROUP (Pre-Mod. 579)				1	—	C	52/26

SHACKLETON Mk 2

MAIN PLANES
TRAILING EDGE OUTBOARD

Ref. No.	Part No.	Description				No. off	Matl. Spec.	Cl. of St.	Plate and Illust'n No.
		1	2	3	4			M.R.	
5599	2F9709	PANEL, UNDRILLED, No. 2A, BETWEEN RIBS No. 5 & 6, STARBOARD, GROUP (Mod. 579)				1	—	C	52/26
4338	1F8354	PANEL, UNDRILLED, No. 2B, BETWEEN RIBS, No. 7 & 9, PORT, GROUP				1	—	C	52/27
1138	1F6753	PANEL, UNDRILLED, No. 4, BETWEEN RIBS, No. 15 and 16, PORT, GROUP (Pre Mod. 579)				1	—	C	
5590	1F9715	PANEL, UNDRILLED, No. 4, BETWEEN RIBS, No. 15 and 16, PORT, GROUP (Mod. 579)				1	—	C	
1139	2F6753	PANEL, UNDRILLED, No. 4 BETWEEN RIBS No. 16 and 17, STARBOARD, GROUP (Pre Mod. 579)				1	—	C	
5594	2F9715	PANEL, UNDRILLED, No. 4, BETWEEN RIBS, No. 16 and 17 STARBOARD, GROUP (Mod. 579)				1	—	C	
4339	2F8354	PANEL, UNDRILLED, No. 2B, BETWEEN RIBS No. 7 & 9, STARBOARD, GROUP				1	—	C	52/28
546	1F5439	PANEL, UNDRILLED, No. 3, BETWEEN RIBS, No. 9 TO 13, PORT, GROUP (Pre Mod. 579)				1	—	M/C	52/29
547	2F5439	PANEL, UNDRILLED, No. 3, BETWEEN RIBS, No. 9 to 13, STARBOARD, GROUP, (Pre Mod. 579)				1	—	M/C	52/30
13173	4F3999	Spares for :— DOOR, INSPECTION, WITH LABEL "ACCESS TO AILERON CONTROL" GROUP				1	L72	C	52/31
13003	4SS3158	Spares for :— Screw, csk.hd, 120° x 2BA x .431" long				6	S1	C	52/32
5589	1F9713	PANEL, UNDRILLED, No. 3, BETWEEN RIBS, No. 9 to 13, PORT, GROUP (Mod. 579)				1	—		
5593	2F9713	PANEL, UNDRILLED, No. 3, BETWEEN RIBS No. 9 to 13, STARBOARD, GROUP (Mod. 579)				1	—		
28Q/9374	AGS2050/630/BS	Rivets, pop dome hd, 3/16" for assembly panels				1131	—	C	
13861	1F5432	TUBE, FLAP, OPERATING, PORT, GROUP				1	—	M/C	52/33
13862	1F5434	TUBE, FLAP, OPERATING, STARBOARD, GROUP				1	—	M/C	52/34
13030	4F3913	Spares for :— Cap				1	L40	C	
13031	2F3913	Circlip, Seegers internal type				9	—	C	
13594	11F3913	Clip, spring				1	Spring Steel	C	
13034	10F3913	Nut, cap				1	L40	C	
13595	6F3913	Nut, lock				1	S1	C	
13033	5F3913	Plug, ball end				1	DTD126	C	
VAPOUR VENT SYSTEM (39P2436) (See Services—Fuel Installation)									

SHACKLETON Mk. 2

MAIN PLANES

TRAILING EDGE (OUTBOARD)

Ref. No.	Part No.	Description				No. off	Matl. Spec.	Cl. of St. M.R.	Plate and Illust'n No.
		1	2	3	4				
COMPLEMENTARY ITEMS									
ATTACHMENT FITTINGS, AILERON PUSH PULL CONTROL ROD OUTER TO LEVER AT RIB 19, PORT AND STARBOARD (R2468)									
Consisting of:—									
13175	17R2226	Bolt, hex.hd, $\frac{3}{8}$ " BSF x $1\frac{5}{16}$ " long, connecting aileron control to lever (Pre Mod. 519)				1	S1	C	1/57
13067	14R2060	Bush, CT24 x $\frac{5}{8}$ " long to lever attachment				1	Oilite	C	
28M/772	A16Y/JS	Nut, slotted, $\frac{3}{8}$ " BSF				1	—	C	
28P/5032	AGS784/3	Pin, split, $\frac{1}{16}$ " dia. x 1" long (Pre Mod 519)				1	Nickel Alloy	C	
28P/12462	SP9/C8	Pin, split, $\frac{1}{16}$ " dia. x 1" long (Mod. 519)				1	Nickel Alloy	C	
5084	3R2468	Bolt, special, $\frac{3}{8}$ " BSF x 1.938" long (Mod. 519)				1	S1	C	
28W/3078	AGS160/J	Washer, for $\frac{3}{8}$ " dia. bolts				1	Mild Steel	C	
ATTACHMENT FITTING, AILERON, PUSH PULL CONTROL ROD, INNER TO INTERMEDIATE LEVER AT FUSELAGE CENTRE PORTION REAR SPAR (R2499)									
(See Complementary Items—Trailing Edge Inboard)									
ATTACHMENT FITTINGS, INBOARD AILERON TO OUTBOARD TRAILING EDGE AT RIBS 14 AND 18, PORT AND STARBOARD (F5427 & F5428) (Pre-Mod. 578)									
Consisting of:—									
28D/8457	AS1882/2C	Bolt, csk.hd, 2 BA x .6" long for bonding lead				1	—	C	1/58
13022	5F3806	Bolt, hex.hd, $\frac{5}{8}$ " BSF x $2\frac{1}{8}$ " long				2	S1	C	
5533	3F5427	Bush, for bolts (Mod. 578)				4	L40	C	
13027	6F3806	Bush, for above bolts (Pre-Mod. 578)				4	L40	C	
28M/5381	A16Y/QS	Nut, slotted $\frac{5}{8}$ " BSF				2	—	C	
28M/10328	AGS2002/C/1	Nut, stiff 2BA				2	—	C	
28P/5045	AGS784/21	Pin, split, $\frac{1}{8}$ " dia. x $1\frac{1}{2}$ " long				2	Nickel Alloy	C	
13029	QSS1683	Washer, for $\frac{5}{8}$ " dia. bolts				1	Mild Steel	C	
28W	AGS160C	Washer, 2 BA				1	—	C	
ATTACHMENT FITTINGS, FLAP EXTENSION ATTACHMENT TO OUTER TRAILING EDGE, PORT AND STARBOARD (F8327 & F8328)									
Consisting of:—									
28D/12532	A25/4C	Bolt, hex.hd, 2 BA x 0.85" long				43	—	C	1/59
13895	16F3588	Washer				43	L3	C	
ATTACHMENT FITTINGS, FLAP ATTACHMENT TO OUTER WING, TRAILING EDGE (F8327 & F8328) (Pre-Mod. 579)									
Consisting of:—									
28D/12532	A25/4C	Bolt, hex.hd, 2 BA x 0.85" long				74	—	C	1/60
13895	16F3588	Washer				74	L3	C	

MAIN PLANES
TRAILING EDGE (OUTBOARD)

Ref. No.	Part No.	Description				No. off	Matl. Spec.	Cl. of St.	Plate and Illust'n No.
		1	2	3	4			M.R.	
		ATTACHMENT FITTINGS TRAILING EDGE TO INNER MAIN PLANE (See Complementary Items, Inner Mainplane Assembly)							
		SUMMARY OF STOCK ITEMS USED ON TRAILING EDGE OUTBOARD ASSEMBLY							
28D/9436920	A25/1C	Bolt,	hex.hd,	2 BA x 0.55" long	...	90	—	C	
28D/12140	AS1246/8C	Bolt,	mush.hd,	2 BA x 1.20" long...	...	6	—	C	
28D/1007982	AS1248/1C	Bolt,	mush.hd,	2 BA x 0.5" long	...	6	—	C	
28D/8345	AS1248/7C	Bolt,	mush.hd,	2 BA x 1.1" long	...	6	—	C	
28D/8346	AS1248/8C	Bolt,	mush.hd,	2 BA x 1.2" long	...	8	—	C	
28M/10288	AGS2001/C/1	Nut,	stiff, hex.hd,	2 BA	...	20	—	C	
28 M/11957	AGS2007/C/1	Nut,	double anchor	2 BA	...	84	—	C	
28M/10740	AGS2014/B/11	Nut,	floating anchor		...	16	—	C	

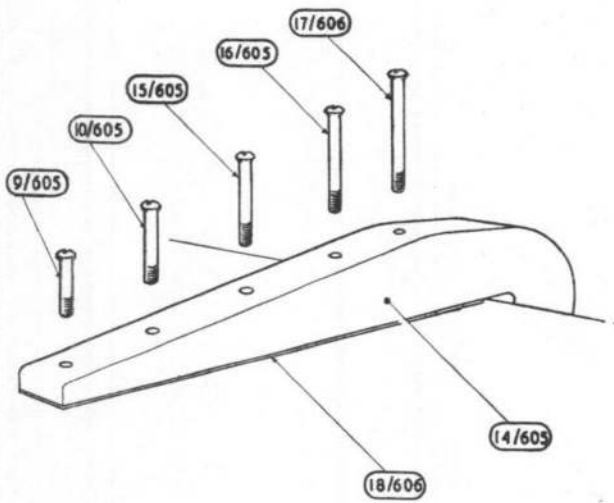
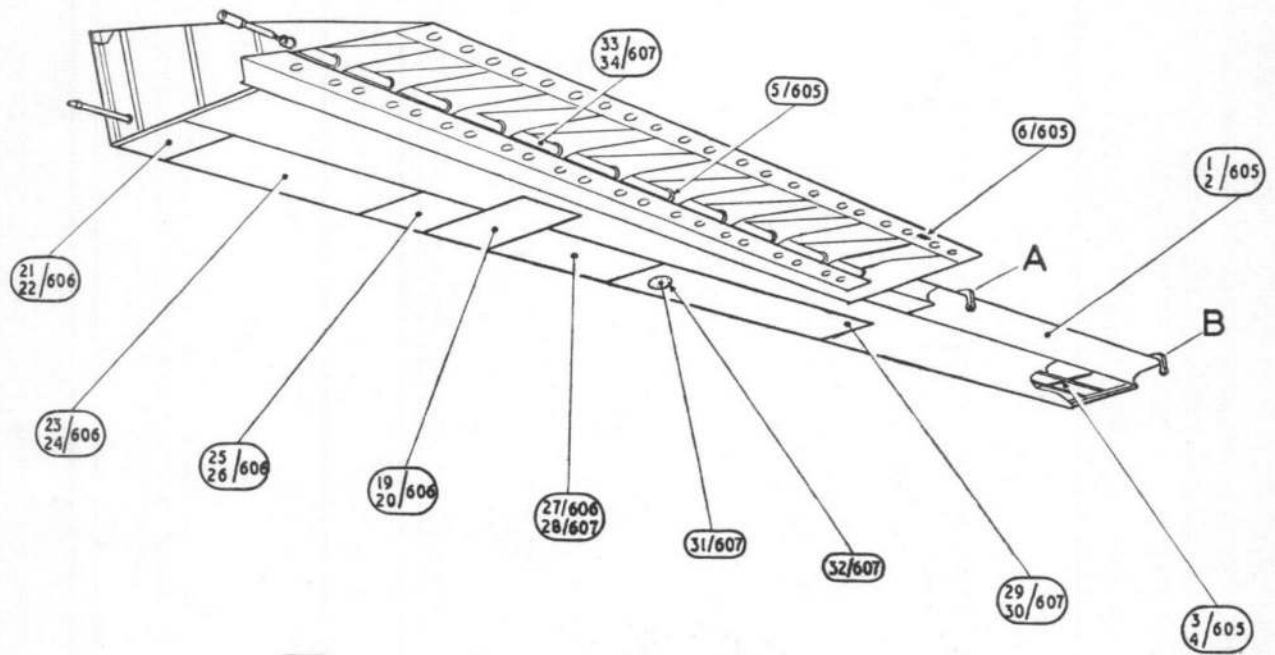

AILERON HINGE AT B

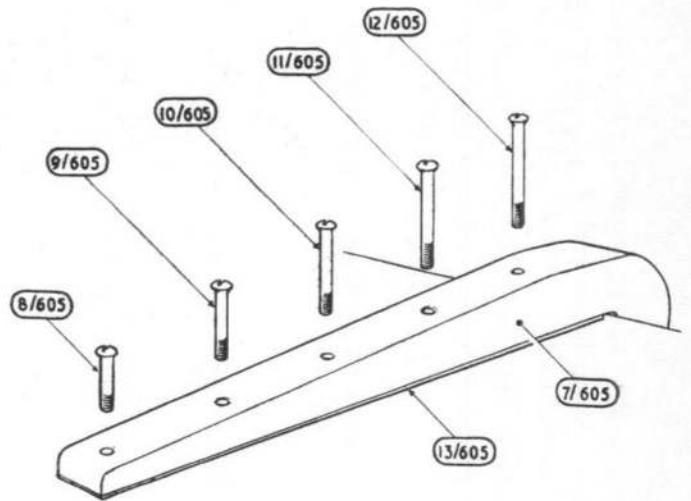

AILERON HINGE AT A

MAIN PLANES TRAILING EDGE OUTBOARD

DATE NO. 1

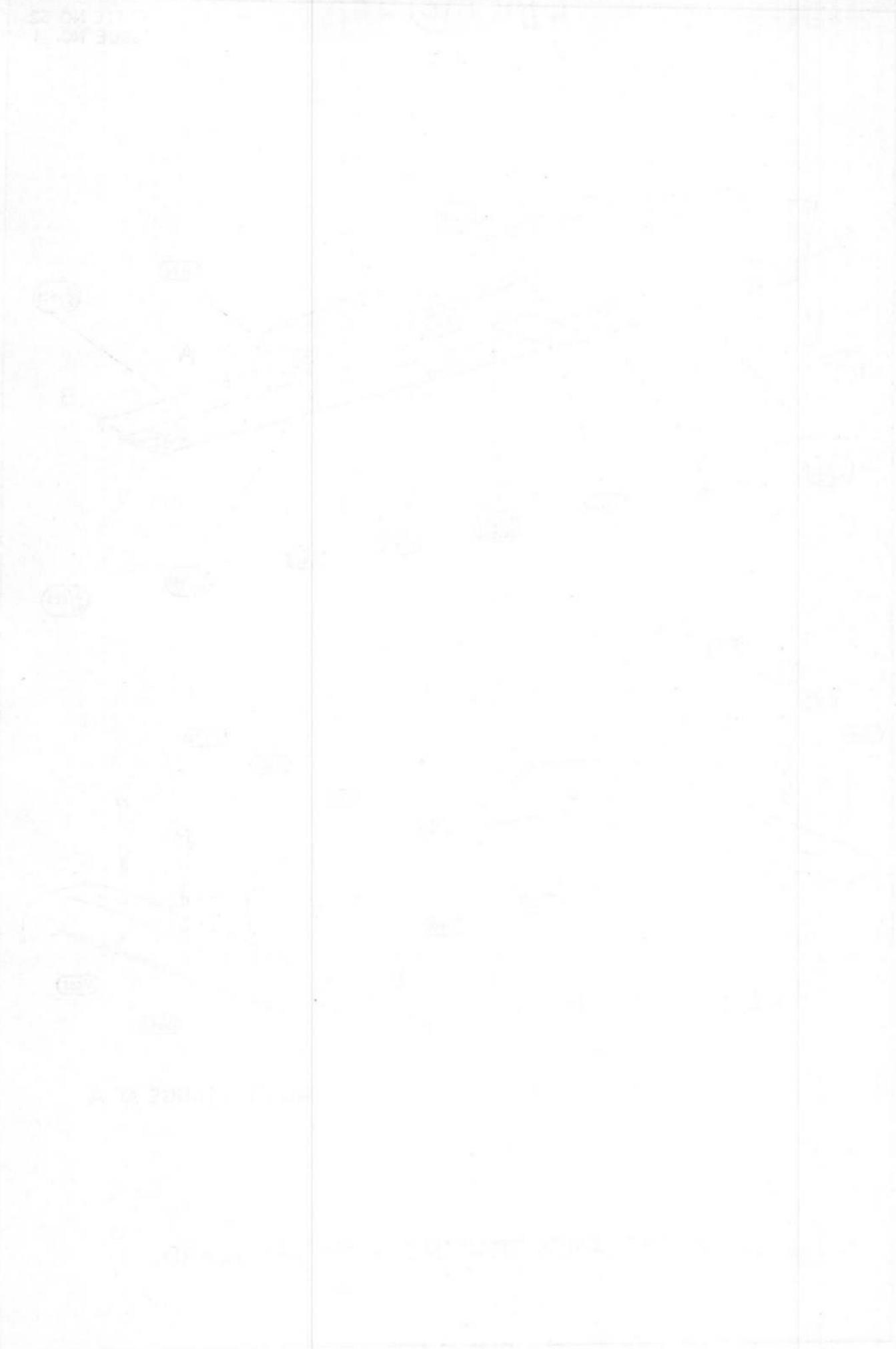

SHACKLETON Mk. 2

**MAIN PLANES
FLAPS (INBOARD)**

Ref. No.	Part No.	Description				No. off	Matl. Spec.	Cl. of St.	Plate and Illust'n No.
		1	2	3	4			M.R.	
77 78	1F6794 1F6795	FLAP, INBOARD, ASSEMBLY, PORT ... FLAP, INBOARD, ASSEMBLY, STARBOARD (Complementary parts, e.g., Inter-Component attachments are listed at the end of the "TRAILING EDGE INBOARD")				1 1	— —	A A	53/1 53/2
13057	2SS3261	Spares for :— Bolt , flat hd, 4 BA x $\frac{3}{8}$ " long for serial and mod. plates				4	S1	C	
28D/8307 13371	AS1242/2C 2F4716 4F6794 4F6795	Bolt , 2 BA x $\frac{1}{2}$ " long, csk.hd, 90°, hinges to flap Buffer , on trailing edge strip, $\frac{3}{8}$ " o/d x $2\frac{1}{2}$ " long Edge , trailing (Extrusion 9SS3075) Edge , trailing (Extrusion 9SS3075)				50 4 1 1	MS Rubber DTD259 DTD259	C C C	53/3 53/4 53/5
1088	11F6794	HINGE, WITH PIN, AT RIB 27, PORT, GROUP Consisting of :— Hinge , half, 16 SWG Hinge , half, 16 SWG Nut , 2 BA, for hinge pin Pin , for hinges, $\frac{1}{4}$ " dia. Rivet , csk.hd, 120° x $\frac{1}{8}$ " dia. x $\frac{3}{16}$ " long				1	—	C	53/6
28M/5316 28Q/10680	11aF6794 9aF6420 A16Y/CP 11bF6794 AS2230/403	HINGE, WITH PIN, PORT, GROUP ... Consisting of :— Hinge , half, 16 SWG Hinge , half, 16 SWG Nut , 2 BA, for hinge pin Pin , for hinges, $\frac{1}{4}$ " dia. Rivet , csk.hd, 120°, $\frac{1}{8}$ " dia. x $\frac{3}{16}$ " long				1 1 2 1 10	L72 L72 — DTD327 DTD327	C C C	
1089	12F6794	HINGE, WITH PIN, PORT, GROUP ... Consisting of :— Hinge , half, 16 SWG Hinge , half, 16 SWG Nut , 2 BA, for hinge pin Pin , for hinges, $\frac{1}{4}$ " dia. Rivet , csk.hd, 120°, $\frac{1}{8}$ " dia. x $\frac{3}{16}$ " long				1	—	C	53/7
28M/5316 28Q/10680	12aF6794 25aF3664 A16Y/CP 12bF6794 AS2230/403	HINGE, WITH PIN, PORT, GROUP ... Consisting of :— Hinge , half, 16 SWG Hinge , half, 16 SWG Nut , 2 BA, for hinge pin Pin , for hinges, $\frac{1}{4}$ " dia. Rivet , csk.hd, 120°, $\frac{1}{8}$ " dia. x $\frac{3}{16}$ " long				1 1 2 1 12	L72 L72 — S1 DTD327	C C	
1090	13F6794	HINGE, WITH PIN, PORT, GROUP ... Consisting of :— Hinge , half, 16 SWG Hinge , half, 16 SWG Nut , 2 BA, for hinge pin Pin , for hinges, $\frac{1}{4}$ " dia. Rivet , csk.hd, 120°, $\frac{1}{8}$ " dia. x $\frac{3}{16}$ " long				1	—	C	53/8
28M/5316 28Q/10680	13aF6794 5bF6420 A16Y/CP 13bF6794 AS2230/403	HINGE, WITH PIN, PORT, GROUP ... Consisting of :— Hinge , half, 16 SWG Hinge , half, 16 SWG Nut , 2 BA, for hinge pin Pin , for hinges, $\frac{1}{4}$ " dia. Rivet , csk.hd, 120°, $\frac{1}{8}$ " dia. x $\frac{3}{16}$ " long				1 1 2 1 10	L72 L72 — S1 DTD327	C C	
1091	10F6795	HINGE, WITH PIN, STARBOARD, GROUP Consisting of :— Hinge , half, 16 SWG Hinge , half, 16 SWG Nut , 2 BA, for hinge pin Pin , for hinge, $\frac{1}{4}$ " dia. Rivet , csk.hd, 120°, $\frac{1}{8}$ " dia. x $\frac{1}{4}$ " long...				1	—	C	53/9
6885 28M/5316 28Q/10412	10aF6795 5aF6421 A16Y/CP 10bF6795 AS2230/404	HINGE, WITH PIN, STARBOARD, GROUP Consisting of :— Hinge , half, 16 SWG Hinge , half, 16 SWG Nut , 2 BA, for hinge pin Pin , for hinge, $\frac{1}{4}$ " dia. Rivet , csk.hd, 120°, $\frac{1}{8}$ " dia. x $\frac{1}{4}$ " long...				1 1 2 1 5	L72 L72 — S1 DTD327	C C C	

**MAIN PLANES
FLAPS (INBOARD)**

Ref. No.	Part No.	Description				No. off	Matl. Spec.	Cl. of St.	Plate and Illust'n No.
		1	2	3	4			M.R.	
1092	11F6795	HINGE, WITH PIN, STARBOARD, GROUP				1	—	C	53/10
		Consisting of:—							
	11aF6795	Hinge, half, 16 SWG				1	L72		
	19aF6421	Hinge, half, 16 SWG				1	L72		
28M/5316	A16Y/CP	Nut, 2 BA, for hinge pin				2	—	C	
	11bF6795	Pin, for hinges, $\frac{1}{4}$ " dia.				1	S1		
28Q/10412	AS2230/404	Rivet, csk.hd, 120°, $\frac{1}{8}$ " dia. x $\frac{1}{4}$ " long ...				13	DTD327	C	
1093	12F6795	HINGE, WITH PIN, STARBOARD, GROUP				1	—	C	53/11
		Consisting of:—							
	12aF6795	Hinge, half, 16 SWG				1	L72		
13746	5aF3665	Hinge, half, 16 SWG				1	L72	C	
28M/5316	A16Y/CP	Nut, 2 BA, for hinge pin				2	—	C	
	12bF6795	Pin, for hinges, $\frac{1}{4}$ " dia.				1	S1		
28Q/10412	AS2230/404	Rivet, csk.hd, 120°, $\frac{1}{8}$ " dia. x $\frac{1}{4}$ " long ...				12	DTD327	C	
1087	13F6795	HINGE, WITH PIN, PORT AND STARBOARD, GROUP				2	—	C	53/12
		Consisting of:—							
	13aF6795	Hinge, half, 16 SWG				1	L72		
13363	10aF3664	Hinge, half, 16 SWG				1	L72	C	
28M/5316	A16Y/CP	Nut, 2 BA, for hinge pin				2	—	C	
	13bF6795	Pin, for hinges, $\frac{1}{4}$ " dia.				1	S1		
28Q/10412	AS2230/404	Rivet, csk.hd, 120°, $\frac{1}{8}$ " dia. x $\frac{1}{4}$ " long ...				12	DTD327	C	
13043	1SS3259	Plate, modification record				1	—	C	
13044	1SS3260	Plate, serial No.				1	—	C	

SHACKLETON Mk 2

MAIN PLANES
FLAPS (INBOARD)

Ref. No.	Part No.	Description				No. off	Matl. Spec.	Cl. of St.	Plate and Illust'n No.
		1	2	3	4			M.R.	
	2F6458	RIB, END, INBOARD, SHORT, PORT, GROUP				1	DTD610		53/13
	2F6459	RIB, END, INBOARD, LONG, PORT, GROUP				1	DTD610		53/14
	1F6458	RIB, END, INBOARD, SHORT, STARBOARD, GROUP				1	DTD610		53/15
	1F6459	RIB, END, INBOARD, LONG, STARBOARD, GROUP				1	DTD610		53/16
13367	1F3753	RIB, END, OUTER, PORT, GROUP ...				1	DTD610	M/C	53/17
	2F6554	RIB, END, OUTER, STARBOARD, GROUP				1	DTD610		53/18
28Q/9251	AGS2051/ 419BS	Rivet, pop, csk. $\frac{1}{8}$ " dia. x .211" long, for attaching buffer to flaps (4SS3124)				8	DTD237	C	
	1F6461	SPAR, FLAP, PORT, GROUP ...				1	—		53/19
	1F6455	SPAR, FLAP, STARBOARD, GROUP ...				1	—		53/20
		Spares for :—							
26EA/17674	2F3749	Bobbin, for bush				3	—	C	53/21
13055	3F3749	Bush, for eyebolt				6	B6	C	53/22
13054	4F3749	Eyebolt				3	S2 or S11	C	53/23
13056	5F3749	Washer, wearing, for eyebolts				3	DTD124	C	53/24
	1F6871	STRIP, LEADING EDGE, PORT, GROUP				1	—		53/25
	1F6874	STRIP, LEADING EDGE, STARBOARD, GROUP				1	—		53/26
	1F6520	Strip, trailing edge, port				1	DTD610		53/27
	1F6521	Strip, trailing edge, starboard				1	DTD610		53/28

MAIN PLANES
FLAPS (INBOARD)

Ref. No.	Part No.	Description				No. off	Matl. Spec.	Cl. of St.	Plate and Illust'n No.
		1	2	3	4			M.R.	
SUMMARY OF STOCK ITEMS USED ON FLAPS (INBOARD) ASSEMBLY									
28M/10288	AGS2001/C/1	Nut, stiff, 2 BA	50		C	
28M/774	A16Y/LS	Nut, slotted, $\frac{7}{16}$ " BSF	3	—	C	53/29
28P/5039	AGS784/12	Pin, split $\frac{3}{32}$ " x $1\frac{1}{4}$ " long	3		C	53/30
28W/8516	AS470/C	Washer	50	—	C	

SHACKLETON Mk 2

MAIN PLANES
FLAPS (OUTBOARD)

Ref. No.	Part No.	Description				No. off	Matl. Spec.	Cl. of St.	Plate and Illust'n No.
		1	2	3	4			M.R.	
79	1F6877	FLAP, OUTBOARD, ASSEMBLY, PORT				1	—	A	53/31
80	1F6883	FLAP, OUTBOARD, ASSEMBLY, STARBOARD				1	—	A	53/32
		(Complementary parts, e.g., Inter-component attachments are listed at the end of the "Trailing Edge outboard")							
		Spares for :—							
13057	2SS3261	Bolt , flat hd, 4 BA x $\frac{3}{8}$ " for serial and mod. plates				4	S1	C	
28D/8457	AS1882/2C	Bolt , 2 BA, csk.hd, 90° x .60" long for attaching hinges to flap				82	MS	C	
13371	2F4716	Buffer , on trailing edge strip $\frac{3}{8}$ " dia. x 2 $\frac{1}{2}$ " long				8	Rubber		53/3
	4F6529	Edge , trailing extrusion (9SS3075)				1	DTD259		52/33
	4F6532	Edge , trailing extrusion (9SS3075)				1	DTD259		53/34
1081	2F6877	HINGE, COMPLETE WITH PIN, PORT, GROUP				6	—	C	53/35
		Consisting of :—							
13771	10aF4293	Hinge , half, 16 SWG				1	DTD610	C	
	2aF6877	Hinge , half, 16 SWG				1	DTD610	C	
28M/5316	A16Y/CP	Nut , 2 BA				2	—	C	
	2bF6883	Pin , for hinge $\frac{1}{4}$ " dia.				1	S1	C	
28Q/10412	AS2230/404	Rivet , csk.hd, 120°, $\frac{1}{8}$ " dia. x $\frac{1}{4}$ " long ...				12	DTD327		
1086	3F6877	HINGE, COMPLETE WITH PIN, PORT, GROUP				1	—	C	53/36
		Consisting of :—							
	3cF6877	Hinge , half, 16 SWG				1	DTD610		
	3aF6877	Hinge , half, 16 SWG				1	DTD610		
28M/5316	A16Y/CP	Nut , 2 BA				2	—	C	
	3bF6877	Pin , for hinges, $\frac{1}{4}$ " dia.				1	S1		
28Q/10412	AS2230/404	Rivet , csk.hd, 120°, $\frac{1}{8}$ " dia. x $\frac{1}{4}$ " long ...				8	DTD327	C	
1083	6F6877	HINGE, COMPLETE WITH PIN, PORT, GROUP				1	—	C	53/37
		Consisting of :—							
26EA/32240	23aF4293	Hinge , half, 16 SWG				1	DTD610	C	
	6aF6877	Hinge , half, 16 SWG				1	DTD610	C	
28M/5316	A16Y/CP	Nut , 2 BA				2	—	C	
	2bF6881	Pin , for hinges, $\frac{1}{4}$ " dia.				1	S1		
28Q/10412	AS2230/404	Rivet , csk.hd, 120°, $\frac{1}{8}$ " dia. x $\frac{1}{4}$ " long ...				8	DTD327	C	

**MAIN PLANES
FLAPS (OUTBOARD)**

Ref. No.	Part No.	Description				No. off	Matl. Spec.	Cl. of St.	Plate and Illust'n No.
		1	2	3	4			M.R.	
1084	2F6883	HINGE, COMPLETE WITH PIN, STARBOARD, GROUP				6	—	C	53/38
		Consisting of:—							
26EA/18465	10aF4294	Hinge, half, 16 SWG	1	DTD610	C	
	2aF6883	Hinge, half, 16 SWG	1	DTD610	C	
28M/5316	A16Y/CP	Nut, 2 BA	2	—	C	
	2bF6883	Pin, for hinges, 1/4" dia.	1	S1	C	
28Q/10412	AS2230/404	Rivet, csk.hd, 120°, 1/8" dia. x 1/4" long	12	DTD327	C	
1082	4F6877	HINGE, COMPLETE WITH PIN, STARBOARD, GROUP				1	—	C	53/39
		Consisting of:—							
	4bF6877	Hinge, half, 16 SWG	1	DTD610	C	
	4aF6877	Hinge, half, 16 SWG	1	DTD610	C	
28M/5316	A16Y/CP	Nut, 2 BA	2	—	C	
	3bF6877	Pin, for hinges, 1/4" dia.	1	S1	C	
28Q/10412	AS2230/404	Rivet, csk.hd, 120°, 1/8" dia. x 1/4" long	8	DTD327	C	
1085	5F6877	HINGE, COMPLETE WITH PIN, STARBOARD, GROUP				1	—	C	53/40
		Consisting of:—							
26EA/32244	24aF4293	Hinge, half, 16 SWG	1	DTD610	C	
	5aF6877	Hinge, half, 16 SWG	1	DTD610	C	
	2bF6881	Pin, for hinges, 1/4" dia.	1	—	C	
28M/5316	A16Y/CP	Nut, 2 BA	2	—	C	
28Q/10412	AS2230/404	Rivet, csk.hd, 120°, 1/8" dia. x 1/4" long	8	DTD327	C	
13043	1SS3259	Plate, modification, record	1	—	C	
13044	1SS3260	Plate, serial No.	1	—	C	
13222	1F4302	RIB, END, OUTER, PORT, GROUP				1	—	M/C	53/41
13664	2F4301	RIB, END, INNER, STARBOARD, GROUP				1	—	M/C	53/42
13221	1F4301	RIB, END, INNER, PORT, GROUP				1	—	M/C	53/43
13665	2F4302	RIB, END, OUTER, STARBOARD, GROUP				1	—	M/C	53/44
28Q/9251	AGS205/419BS	Rivet, pop, csk.hd, 1/8" dia. x .211" for attaching buffer to flap (4SS3124)				8	DTD237	C	
	10F6530	SPAR, PORT, GROUP				1	—		53/45
	10F6533	SPAR, STARBOARD, GROUP				1	—		53/46
		Spares for:—							
26EA/17674	2F3749	Bobbin, for bush	6	—	C	53/21
13055	3F3749	Bush, for eyebolt	12	B6	C	53/22
13054	4F3749	Eyebolt	6	S2 or S11	C	53/23
13056	5F3749	Washer, wearing, for eyebolts	6	DTD124	C	53/24
	1F6879	STRIP, LEADING EDGE, PORT, GROUP				1	—		53/47
	1F6884	STRIP, LEADING, EDGE, STARBOARD, GROUP				1	—		53/48
13662	1F4299	Strip, trailing edge, port	1	DTD610	M/C	53/49
13663	1F4300	Strip, trailing edge, starboard	1	DTD610	M/C	53/50

MAIN PLANES
FLAPS (OUTBOARD)

Ref. No.	Part No.	Description				No. off	Matl. Spec.	Cl. of St.	Plate and Illust'n No.
		1	2	3	4			M.R.	
SUMMARY OF STOCK ITEMS USED ON FLAPS (OUTBOARD) ASSEMBLY									
28M/10288	AGS2001/C/1	Nut, stiff, 2 BA	82	—	C C C C	
28M/774	A16Y/LS	Nut, slotted, $\frac{7}{16}$ " BSF	6	—		
28P/5039	AGS784/12	Pin, split, $\frac{3}{32}$ " x $1\frac{1}{4}$ " long	6	—		
28W/12252	SP13/C	Washer, plain, 2 BA	82	—		

SHACKLETON Mk. 2

**MAIN PLANES
FLAP EXTENSION**

Ref. No.	Part No.	Description				No. off	Matl. Spec.	Cl. of St.	Plate and Illust'n No.
		1	2	3	4			M.R.	
81	1F6881	FLAP, EXTENSION, ASSEMBLY, OUTBOARD, PORT				1	—	A	53/51
82	1F6882	FLAP, EXTENSION, ASSEMBLY, OUTBOARD, STARBOARD				1	—	A	53/52
		(Complementary parts, e.g., Inter-Component attachments are listed at the end of the "TRAILING EDGE OUTBOARD")							
13057	2SS3261	Spares for :— Bolt , flat hd, 4 BA x $\frac{3}{8}$ " long, for serial and mod. plates				4	S1	C	
28D/8457	AS1882/2C	Bolt , 2 BA, csk.hd, for hinges... ..				46	MS	C	
28D/8458	AS1882/3C	Bolt , 2 BA, csk.hd, for hinges... ..				2	MS	C	
13371	2F4716	Buffer , "Rubo", $\frac{3}{8}$ " o/d x $2\frac{1}{2}$ " long... ..				5	Rubber	C	53/3
	4F6522	Edge , trailing, port, (extrusion)... ..				1	—		53/53
	4F6526	Edge , trailing, starboard... ..				1	—		53/54
1081	2F6877	HINGE, WITH PIN, PORT, GROUP ...				3	—	C	53/55
		Consisting of :—							
13771	10aF4293	Hinge , half, 16 SWG... ..				1	L72	C	
	2aF6877	Hinge , half, 16 SWG... ..				1	L72		
28M/5316	A16Y/CP	Nut , 2 BA... ..				2	—	C	
7102	2bF6883	Pin , for hinges, $\frac{1}{4}$ " dia... ..				1	S1		
28Q/10412	AS2230/404	Rivet , csk.hd, 120°, $\frac{1}{8}$ " dia. x $\frac{1}{4}$ " long... ..				12	DTD327	C	
1084	2F6883	HINGE, WITH PIN, STARBOARD, GROUP				3	—	C	53/56
		Consisting of :—							
26EA/18465	10aF4294	Hinge , half, 16 SWG... ..				1	L72	C	
	2aF6883	Hinge , half, 16 SWG... ..				1	L72		
28M/5316	A16Y/CP	Nut , 2 BA... ..				2	—	C	
	2bF6883	Pin , for hinges, $\frac{1}{4}$ " dia... ..				1	S1		
28Q/10412	AS2230/404	Rivet , csk.hd, 120°, $\frac{1}{8}$ " dia. x $\frac{1}{4}$ " long... ..				12	DTD327	C	
1094	2F6881	HINGE, WITH PIN, PORT, GROUP				1	—	C	53/57
		Consisting of :—							
	11aF5431	Hinge , half... ..				1	L72		
	2aF6881	Hinge , half... ..				1	L72		
28M/5316	A16Y/CP	Nut , 2 BA... ..				2	—	C	
	2bF6881	Pin , for hinges, $\frac{1}{4}$ " dia... ..				1	S1		
28Q/10412	AS2230/404	Rivet , csk.hd, 120°, $\frac{1}{8}$ " dia. x $\frac{1}{4}$ " long... ..				8	DTD327	C	

MAIN PLANES
FLAP EXTENSION

Ref. No.	Part No.	Description				No. off	Matl. Spec.	Cl. of St.	Plate and Illust'n No.
		1	2	3	4			M.R.	
1096	3F6881	HINGE, WITH PIN, STARBOARD, GROUP				1	—	C	53/58
		Consisting of:—							
	12aF5431	Hinge, half	1	L72		
	3aF6881	Hinge, half	1	L72		
28M/5316	A16Y/CP	Nut, 2 BA	2	—	C	
	2bF6881	Pin, for hinges, $\frac{1}{4}$ " dia.	1	S1		
28Q/10412	AS2230/404	Rivet, csk.hd, 120°, $\frac{1}{8}$ " dia. x $\frac{1}{4}$ " long	8	DTD327	C	
1095	4F6881	HINGE, WITH PIN, PORT, GROUP				1	—	C	53/59
		Consisting of:—							
	14aF5431	Hinge, half	1	L72		
	4aF6881	Hinge, half	1	L72		
28M/5316	A16Y/CP	Nut, 2 BA	2	—	C	
	4bF6881	Pin, for hinges, $\frac{1}{4}$ " dia.	1	S1		
28Q/10412	AS2230/404	Rivet, csk.hd, 120°, $\frac{1}{8}$ " dia. x $\frac{1}{4}$ " long	6	DTD327	C	
1097	5F6881	HINGE, WITH PIN, STARBOARD GROUP				1	—	C	53/60
		Consisting of:—							
	13aF5431	Hinge, half	1	L72		
	5aF6881	Hinge, half	1	L72		
28M/5316	A16Y/CP	Nut, 2 BA	2	—	C	
	4bF6881	Pin, for hinges, $\frac{1}{4}$ " dia.	1	S1		
28Q/10412	AS2230/404	Rivet, csk.hd, 120°, $\frac{1}{8}$ " dia. x $\frac{1}{4}$ " long	6	DTD327	C	
13043	1SS3259	Plate, modification record	1	—	C	
13044	1SS3260	Plate, serial No.	1	—		
13222	1F4302	RIB, END, OUTER, PORT AND INNER STARBOARD, GROUP				1	—	M/C	53/61
13665	2F4302	RIB, END, INNER, PORT AND OUTER STARBOARD, GROUP				1	—	M/C	53/62
	1F6523	SPAR, FLAP EXTENSION, PORT, GROUP				1	—	MR	
	10F6527X	SPAR, FLAP EXTENSION, STARBOARD, GROUP				1	—	MR	
		Spares for:—							
26EA/17674	2F3749	Bobbin, for bush	3	L40		53/21
13055	3F3749	Bobbin, for eyebolt	6	BSS251		53/22
13054	4F3749	Eyebolt	3	S2		53/23
13056	5F3749	Washer for eyebolt	3	DTD124A		53/24
	6F5431	Strip, trailing edge, port	1	L72		53/63
	6F5436	Strip, trailing edge, starboard	1	L72		53/64

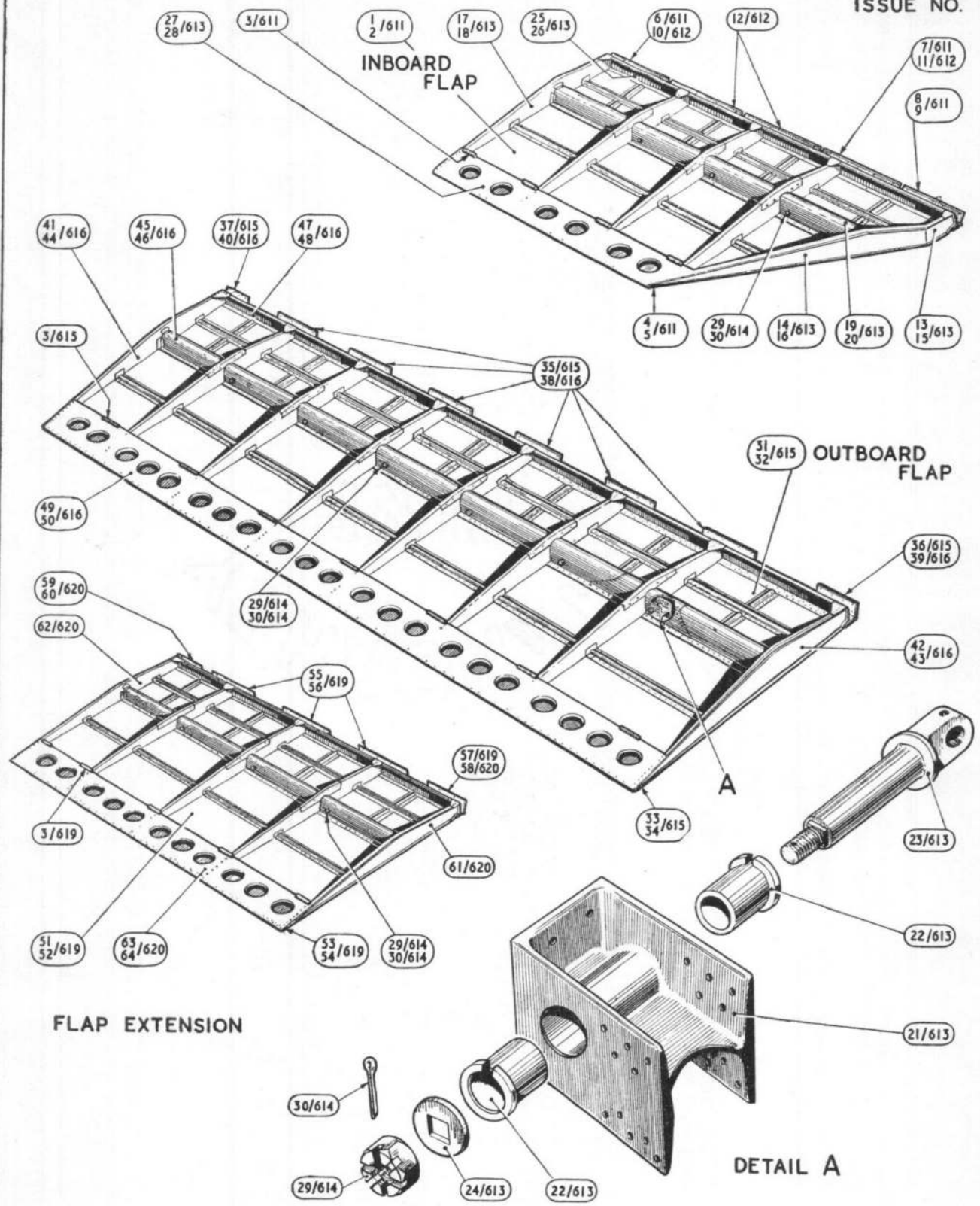

FLAPS

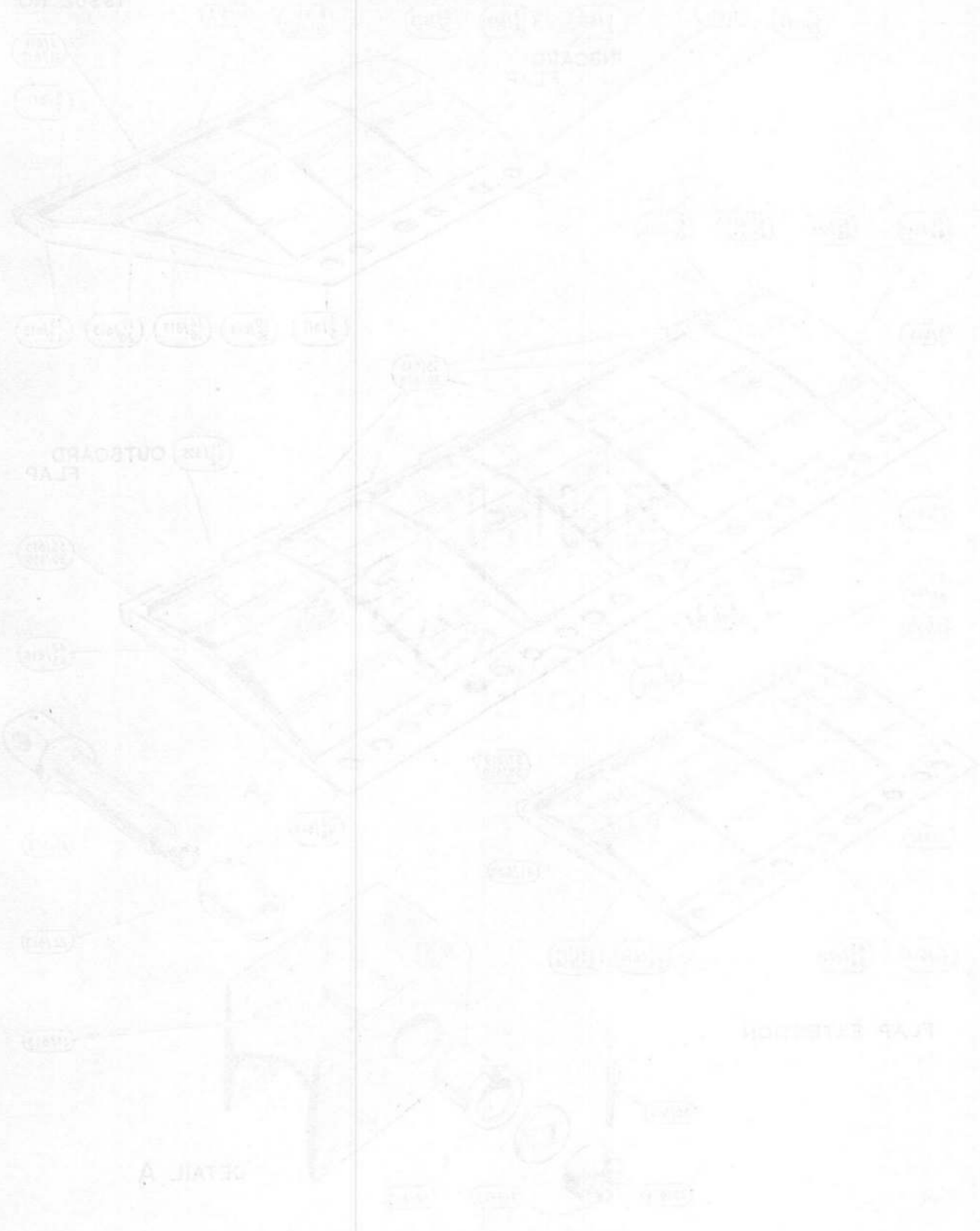

DETAIL A

FLAPS

MAIN PLANES
INNER MAIN PLANE

Ref. No.	Part No.	Description				No. off	Matl. Spec.	Cl. of St.	Plate and Illust'n No.
		1	2	3	4			M.R.	
4004	21F6170	MAIN PLANE, ASSEMBLY, INNER, PORT (Less Fuel Tanks)				1	—	A	54/1
4005	22F6170	MAIN PLANE, ASSEMBLY, INNER, STARBOARD (Less Fuel Tanks)				1	—	A	54/2
(Complementary parts, e.g., Inter-Component attachments listed at the end of this assembly will not be supplied with the assembly spare, and must be demanded separately when required).									
Spares for :—									
530	MESSIER 7M4	Adaptor, de-icing pipes...				10	—	C	66/108
ATTACHMENT, MOORING, INBOARD, PORT AND STARBOARD (1&2F6413)									
Spares for :—									
509	3F6413	DOOR, ACCESS, PORT, GROUP ...				1	—	C	54/3
510	4F6413	DOOR, ACCESS, STARBOARD, GROUP				1	—	C	
Spares for :—									
28FP/155	DZUS A30	Fastener (5SS3545)				2	—	C	
28FP/311	DZUS No. 375	Grommet (1SS3545)				2	—	C	
6844	3eF6413	Hinge, port and starboard				1	—		
	152Z1196	Label				1	—		
	5F6413	Strip, metal, 20 SWG x $\frac{5}{8}$" x $3\frac{3}{4}$"				2	L72		
	6F6413	Strip, felt, $\frac{7}{16}$" x $\frac{3}{4}$" x 10.4" long				1	Felt		
ATTACHMENT, MOORING, OUTBOARD, PORT AND STARBOARD (1&2F5511)									
Spares for :—									
13508	3F5511	DOOR, ACCESS, PORT, GROUP ...				1	—	C	54/5 54/6
13509	4F5511	DOOR, ACCESS, STARBOARD, GROUP				1	—	C	
Spares for :—									
28FP/155	DZUS A30	Fastener (5SS3545)				2	—	C	
7115	3cF5511	Hinge, port				1	—	C	
	4cF5511	Hinge, starboard				1	—		
	152Z1196	Label				1	—		
	11F5511	Strip, packing, 20 SWG x $\frac{3}{4}$" x 12"				1	L72		
	9F5511	Strip, reinforcing, 20 SWG x $\frac{3}{4}$" x 11.5"				1	L72		
	10F5511	Strip, reinforcing, 20 SWG x $\frac{3}{4}$" x 11"				1	L72		
28D/8324	AS1242/3E	Bolt, csk.hd, $\frac{1}{4}$" BSF x .75" long, attachment of tank access doors				582	—	C	
28D/8325	AS1242/4E	Bolt, csk.hd, $\frac{1}{4}$" BSF x .85" long, attachment of tank access doors				36	—	C	

MAIN PLANES
INNER MAIN PLANE

Ref. No.	Part No.	Description				No. off	Matl. Spec.	Cl. of St.	Plate and Illust'n No.
		1	2	3	4			M.R.	
	3F6229	BRACKET, ANCHORAGE, FOR No. 3 TANK STRAPS (1&2F6229) Spares for :— BRACKET, TANK STRAP ATTACHMENT, GROUP				2	—		54/7
13231	14SS3329	CABLES, REBECCA, AERIAL (1&3T2184) (See Radio & Radar) Clip, pipe, 1/4" dia.				10	L72	C	
13726	3SS3512	CONDUIT, ARRANGEMENT FOR ELECTRICAL CABLES, NOSE RIBS 8A-18, PORT AND STARBOARD (1&2F5883) Spares for :— Clip, attachment, at conduit tube to nose ribs, port				9	L72	C	
13726	3SS3512	Clip, attachment, at conduit tube to nose ribs, starboard				2	L72	C	
13637	3SS3266	Clip, attachment, at conduit tube to nose ribs, port				2	L72	C	
13637	3SS3266	Clip, attachment, at conduit tube to nose ribs, starboard				9	L72	C	
13009	6SS2868	Clip, jointing, tube				2	S3	C	
	4F5509	Tube, conduit, 3/4" o/d x 8' 2 3/8" long ...				1	T9		54/8
	3F5883	Tube, conduit, 1/2" o/d x 8' long ...				1	T9		54/9
	10F5513	Tube, jointing, conduit tubes				1	T9		54/10
		CONDUIT AND IGNITION CLEATS, ARRANGEMENT, NOSE RIBS 1-6A, PORT AND STARBOARD (1&2V3828) Spares for :—							
	3V3828	Bracket, on nose ribs 1-6, port ...				6	L72		54/11
	4V3828	Bracket, on nose ribs 1-6, starboard ...				6	L72		54/12
	7V3048	CLIP, CONDUIT, RIB 1 PORT, GROUP Spares for :—				1	—		54/13
	17T2184	CLIP, INSULATOR, GROUP ... Consisting of :—				1	—		
	17aT2184	Body, insulator				1	Perspex		
28M/5233	A14/BB	Nut, 4 BA				1	Brass	C	
28S/2079	AGS246/23	Screw, cheese hd, 4 BA x 5/8" long...				1	Brass	C	
	8V3048	CLIP, CONDUIT, RIBS 2-6, PORT, GROUP Spares for :—				5	—		54/14
	17T2184	CLIP, INSULATOR, GROUP ... Consisting of :—				1	—		
	17aT2184	Body, insulator				1	Perspex		
28M/5233	A14/BB	Nut, 4 BA				1	Brass	C	
28S/2079	AGS246/23	Screw, cheese hd, 4 BA x 5/8" long...				1	Brass	C	

MAIN PLANES
INNER MAIN PLANES

Ref. No.	Part No.	Description				No. off	Matl. Spec.	Cl. of St.	Plate and Illust'n No.
		1	2	3	4			M.R.	
		CONDUIT AND IGNITION CLEATS ARRANGEMENT, NOSE RIBS 1-6A, PORT AND STARBOARD (1&2V3828) (Cont'd)							
	9V3048	CLIP, CONDUIT, RIB 1, STARBOARD, GROUP				1	—		54/15
	17T2184	Spares for :— CLIP, INSULATOR, GROUP ...				1	—		
	17aT2184	Consisting of :— Body, insulator				1	Perspex		
28L5233	A14/BB	Nut, 4 BA				1	Brass	C	
28S/2079	AGS246/23	Screw, cheese hd, 4 BA x 5/8" long...				1	Brass	C	
	10V3048	CLIP, CONDUIT, RIBS 2-6, STARBOARD, GROUP				5	—		54/16
	17T2184	Spares for : CLIP, INSULATOR, GROUP				1	—		
	17aT2184	Consisting of :— Body, insulator				1	Perspex		
28L/5233	A14/BB	Nut, 4 BA				1	Brass	C	
28S/2079	AGS246/23	Screw, cheese hd, 4 BA x 5/8" long...				1	Brass	C	
13268	1SS3628	Cleat, ignition				28	—	C	
	35F5553	Conduit, 3 3/8" o/d x 8' 10 1/2" long				1	L16 or DTD213		54/17
		CONTROLS, ENGINE, ALONG FRONT SPAR, INNER MAINPLANE, PORT AND STARBOARD (3&4O3311) (See Controls—Power)							
		DE-ICING IN MAINPLANE (Z6830) ... (See Services De-icing)							
712	251F5529	DOOR, ACCESS, TO No. 2 TANK, PORT, GROUP				1	—	M/A	54/18
713	252F5529	DOOR, ACCESS, TO No. 2 TANK, STARBOARD, GROUP				1	—	M/A	54/19
1130	276F5529	Spares for :— DOOR, ACCESS, TO FILLER, GROUP				1	—	C	54/20
26DD/25270	1SS3879	Spares for :— CATCH, DOOR, GROUP (See Page 641 for Breakdown)				1	—	C	54/21
3255	1SS3928	Hinge, door				1	—	C	35/146
		DOOR, ACCESS TO TANK SUPPORT STRAPS (1&2F6225) Spares for :—							
13123	17SS3221	Door, access				3	L72	A	54/22
13003	4SS3158	Screw, csk.hd, 2 BA x 1/2" long...				18	S1	C	54/23

MAIN PLANES
INNER MAIN PLANE

Ref. No.	Part No.	Description				No. off	Matl. Spec.	Cl. of St.	Plate and Illust'n No.
		1	2	3	4			M.R.	
		DOOR ACCESS TO No. 2 TANK (251&252F5529) (Cont'd)							
		DOOR, ASSEMBLY, ACCESS TO LIFTING HANDLE (1F6166)							
		Spares for :—							
28D/8484	AS1885/1C					4	—	C	
	4F6166						L40		
714	5F6166					2	—	C	54/24
	3F6166					2	T45		54/25
13911	20SS3221					1	L72	C	54/26
		ELECTRICS, INNER MAINPLANE, PORT AND STARBOARD (1&3V4541)							
		(See Electrical Installation)							
4816	9Q1468					2	—	C	
		FUEL, VENT & NITROGEN SYSTEM, PORT AND STARBOARD (5&6P2895)							
		(See Services—Fuel Installation)							
719	1F6385					2	—	C	54/27
720	2F6385					1	—	C	54/28
721	4F5811					2	—	C	54/29
722	6F5811					1	—	C	54/30
723	1F6513					2	—	C	54/31
724	2F6513					1	—	C	54/32
725	3F5770					1	—	C	54/33
726	4F5770					1	—	C	54/34
1463	14F7181					1	—	C	54/35
1993	3F6385					1	—	C	54/36
	1F5531					1	—		
	2F5531					1	—		
		MEMBER, SUPPORT, REAR, PORT ...							
		MEMBER, SUPPORT, REAR, STARBOARD							
		Spares for :—							
26EA/546	20SS3123					11	—	C	
28Q1940	405AS/455					24	—	C	
	5F5531					1	—		
	6F5531					1	—		
	4SS3543					1	—		
		METHYL BROMIDE FIRE PROTECTION INSTALLATION, PORT AND STARBOARD (2&3P2433)							
		(See Services—Methyl Bromide)							
		MOUNTING OF SWITCHES AND CONDUIT TUBES FOR METHYL BROMIDE FLAME CORDS, PORT AND STARBOARD (1&2Z5213)							
		(See Services—Methyl Bromide Installation)							
528	MESSIER 5M4					26	—	C	66/142
529	MESSIER 4M4					26	—	C	66/143

SHACKLETON Mk. 2

MAIN PLANES

Page 625

INNER MAIN PLANE

Ref. No.	Part No.	Description				No. off	Matl. Spec.	Cl. of St.	Plate and Illust'n No.
		1	2	3	4			M.R.	
		PIPE, FILLER DRAIN, No. 4 TANK (1&2P2453)							
		Spares for :—							
13421	14SS3859	CLIP, FOR DRAIN PIPE, GROUP ...				2	—	C	54/37
32C/21	8P2453	Hose, P.R. 1" bore x 1$\frac{3}{8}$" o/d x 2$\frac{1}{4}$" long ...				1	F7	C	54/38
32C/23	371P2190	Hose, P.R. 1$\frac{1}{8}$" bore x 2$\frac{1}{2}$" long ...				1	F7	C	54/39
7353	11P2453	Pipe, drain, filler to joint, port (Mod. 643)				1	DTD323a	C	54/40
7355	13P2453	Pipe, drain, filler to joint, starboard (Mod. 643)				1	DTD323a	C	54/41
7354	12P2453	Pipe, drain, joint to skin, port (Mod. 643) ...				1	DTD323a	C	54/42
7356	14P2453	Pipe, drain, joint to skin, starboard (Mod. 643)				1	DTD323a	C	54/43
	29F7181	Plate, joint, for nose plates between ribs 12a and 13				1	L72		54/44
	30F7181	Plate, joint, for nose plates between ribs 15a and 15b				1	L72		54/45
1209	1F7182	PLATE, NOSE RIBS 1-6A PORT, GROUP				1	—	C	54/46
		(The following items supplied loose with this Group) :—							
7006	7F7182	Block, end ...				4	L40	C	
7007	10F7182	Block, end ...				4	L40	C	
28D1	AGS1243/7B	Bolt, 4 BA ...				16	—	C	
28M/10287	AGS2001/B1	Nut, hex.hd, 4 BA ...				16	—	C	
28M/12153	AGS2007/B1	Nut, double anchor, 4 BA ...				21	—	C	
28M/8904	AGS2012/B1	Nut, anchor, 4 BA ...				28	—	C	
	8F6684	Plate, nose ...				1	—	C	
28Q/10566	AS2230/303	Rivet, csk.hd, $\frac{3}{32}$" dia. x $\frac{3}{16}$" long ...				48	—	C	
28Q/10432	AS2230/304	Rivet, csk.hd, $\frac{3}{32}$" dia. x $\frac{1}{4}$" long ...				56	—	C	
28Q/10413	AS2230/405	Rivet, csk.hd, $\frac{3}{32}$" dia. x $\frac{5}{16}$" long ...				4	—	C	
28S/8291	AGS968/26	Screws, csk.hd, 4 BA x 1$\frac{1}{4}$" long ...				21	—	C	
28FP/9145889	S6/250	Spring ...				2	—	C	
	15F7182	Strip, packing ...				20	L72		
	37F7182	Strip, packing ...				1	L72		
	17F7182	Strip, packing ...				1	L72		
	18F7182	Strip, packing ...				1	L72		
28W/8515	AS470/B	Washer ...				16	—	C	
6997	3F4878	Washer ...				28	—	C	
	1SS4105	Washer ...				4	S3		

MAIN PLANES

INNER MAIN PLANE

Ref. No.	Part No.	Description				No. off	Matl. Spec.	Cl. of St.	Plate and Illust'n No.
		1	2	3	4			M.R.	
1210	2F7182	PLATE, NOSE RIBS 1-6A STARBOARD, GROUP				1	—	C	54/47
(The following items supplied loose with this Group) :—									
7006	7F7182	Block, end	4	L40	C	
7007	10F7182	Block, end	4	L40	C	
28D/	AGS1243/7B	Bolt, 4 BA	16	—	C	
28M/10287	AGS2001/B1	Nut, hex.hd, 4 BA	16	—	C	
28M/12153	AGS2007/B1	Nut, double anchor, 4 BA	21	—	C	
28M/8904	AGS2012/B1	Nut, anchor, 4 BA	28	—	C	
	9F6684	Plate, nose	1	—		
28Q/10566	AS2230/303	Rivet, csk.hd, $\frac{3}{32}$ " dia. x $\frac{3}{16}$ " long	48	—	C	
28Q/10432	AS2230/304	Rivet, csk.hd, $\frac{3}{32}$ " dia. x $\frac{1}{4}$ " long	56	—	C	
28Q/10413	AS2230/405	Rivet, csk.hd, $\frac{3}{32}$ " dia. x $\frac{5}{16}$ " long	4	—	C	
28S/8291	AGS968/26	Screws, csk.hd, 4 BA x $1\frac{1}{4}$ " long	21	—	C	
28FP/9145889	S6/250	Spring	2	—	C	
	15F7182	Strip, packing	20	L72		
	37F7182	Strip, packing	1	L72		
	17F7182	Strip, packing	1	L72		
	18F7182	Strip, packing	1	L72		
28W/8515	AS470/B	Washer	16	—	C	
	3F4878	Washer	28	—		
26DC/5281	1SS4105	Washer	4	S3		
1207	1F7183	PLATE, NOSE RIBS 8A-13, PORT, GROUP				1	—	C	54/48
(The following items supplied loose with this Group) :—									
7008	7F7183	Block, end	3	L40		
3323	8F7183	Block, end	3	L40		
28D/11447	AS1243/6B	Bolt, 4 BA	6	—	C	
28M/12153	AGS2007/B1	Nut, double anchor, 4 BA	22	—	C	
28M/8904	AGS2012/B11	Nut, anchor, 4 BA	21	—	C	
28Q/10432	AS2230/304	Rivet, csk.hd, $\frac{3}{32}$ " dia. x $\frac{1}{4}$ " long	86	—	C	
28Q/10413	AS2230/405	Rivet, csk.hd, $\frac{3}{32}$ " dia. x $\frac{5}{16}$ " long	4	—	C	
28Q/	AS2230/413	Rivet, csk.hd.	3	—	C	
28S/8291	AGS968/26	Screws, csk.hd, 4 BA x $1\frac{1}{4}$ " long	16	—	C	
28FP/9145889	S6/250	Spring	2	—	C	
6997	3F4878	Washer	21	—		
26DC/5281	1SS4105	Washer	4	S3		

MAIN PLANES
INNER MAIN PLANE

Ref. No.	Part No.	Description				No. off	Matl. Spec.	Cl. of St. M.R.	Plate and Illust'n No.	
		1	2	3	4					
1208	2F7183	PLATE, NOSE RIBS 8A-13 STARBOARD, GROUP				1	—	C	54/49	
		(The following items supplied loose with this Group):—								
	7F7183	Block, end	3	L40	C C C C C C C C C C C C		
	8F7183	Block, end	3	L40			
28D/11447	A1243/6B	Bolt	6	—			
28M/12153	AGS2007/B1	Nut, double anchor, 4 BA	22	—			
28M/8904	AGS2012/B11	Nut, anchor, 4 BA	21	—			
28Q/10432	AS2230/304	Rivet, csk.hd, $\frac{3}{32}$ " dia. x $\frac{1}{4}$ " long	86	—			
28Q/10413	AS2230/405	Rivet, csk.hd, $\frac{3}{32}$ " dia. x $\frac{5}{16}$ " long	4	—			
28Q/	AS2230/413	Rivet, csk.hd.	3	—			
28S/8291	AGS968/26	Screws, csk.hd, 4 BA x $1\frac{1}{4}$ " long	16	—			
27FP/342	S6/250	Spring	2	—			
	3F4878	Washer	21	—			
	1SS4105	Washer	4	S3			
1205	1F7184	PLATE, NOSE RIBS 13-15A PORT,				1	—		C	54/50
		(The following items supplied loose with this group):—								
	5F7184	Block, end	3	L40	C C C C C C C C C C		
	6F7184	Block, end	3	L40			
28M/12153	AGS2007/B1	Nut, double anchor, 4 BA	10	—			
28M/8904	AGS2012/B11	Nut, anchor, 4 BA	15	—			
28Q/10432	AGS2230/304	Rivets, csk.hd, $\frac{3}{32}$ " dia. x $\frac{1}{4}$ " long	50	—			
28Q/10682	AS2230/412	Rivets, csk.hd, $\frac{1}{8}$ " dia. x $\frac{3}{4}$ " long	6	—			
28S/8291	AGS968/26	Screws, csk.hd, 4 BA x $1\frac{1}{4}$ " long	10	—			
	3F4878	Washer	15	—			
1206	2F7184	PLATE, NOSE RIBS 13-15A STARBOARD, GROUP				1	—		C	54/51
		(The following items supplied loose with this Group):—								
	5F7184	Block, end	3	L40	C C C C C C C C C C		
	6F7184	Block, end	3	L40			
28M/12153	AGS2007/B1	Nut, double anchor, 4 BA	10	—			
28M/8904	AGS2012/B11	Nut, anchor, 4 BA	15	—			
28Q/10432	AS2230/304	Rivets, csk.hd, $\frac{3}{32}$ " dia. $\frac{3}{16}$ " long	50	—			
28Q/10682	AS2230/412	Rivet, csk.hd, $\frac{1}{8}$ " dia. x $\frac{3}{4}$ " long	6	—			
28S/8291	AGS968/26	Screws, csk.hd, 4 BA x $1\frac{1}{4}$ " long	10	—			
	3F4878	Washer	15	—			

MAIN PLANES
INNER MAIN PLANE

Ref. No.	Part No.	Description				No. off	Matl. Spec.	Cl. of St.	Plate and Illust'n No.
		1	2	3	4			M.R.	
1203	1F7185	PLATE, NOSE RIBS 15B-18 PORT, GROUP				1	—	C	54/52
		(The following items supplied loose with this Group) :—							
	7F7185	Block, end	3	L40		
28M/12153	AGS2007/B1	Nut, double anchor, 4 BA	10	—	C	
28M/8904	AGS2012/B11	Nut, anchor, 4 BA	15	—	C	
28Q/10432	AS2230/304	Rivets, csk.hd, $\frac{3}{32}$ " dia. x $\frac{3}{16}$ " long	50	—	C	
28Q/10682	AS2230/412	Rivets, csk.hd, $\frac{1}{8}$ " dia. x $\frac{3}{4}$ " long	3	—	C	
28S/8291	AGS968/26	Screws, csk.hd, 4 BA x $1\frac{1}{4}$ " long	10	—	C	
	3F4878	Washer	15	—		
1204	2F7185	PLATE, NOSE RIBS 15B-18 STARBOARD, GROUP				1	—	C	54/53
		(The following items supplied loose with this Group) :—							
	7F7185	Block, end	3	L40		
28M/12153	AGS2007/B1	Nut, double anchor, 4 BA	10	—	C	
28M/8904	AGS2012/B11	Nut, anchor, 4 BA	15	—	C	
28Q/10432	AS2230/304	Rivets, csk.hd, $\frac{3}{32}$ " dia. x $\frac{3}{16}$ " long	50	—	C	
28Q/10682	AS2230/412	Rivets, csk.hd, $\frac{1}{8}$ " dia. x $\frac{3}{4}$ " long	3	—	C	
28S/8291	AGS968/26	Screws, csk.hd, 4 BA x $1\frac{1}{4}$ " long	10	—	C	
	3F4878	Washer	15	—		
	—	RIB, No. 1, NOSE PORTION, PORT, GROUP (9F5198)				1	—		54/54
		Consisting of :—							
	12F7248	Channel, stiffening	2	DTD610		
	24F7248	Channel, stiffening	1	DTD610		
28M/10240	CL/111	Nut, stiff, thin floating anchor	12	—	C	
28M/10673	CJ/111/1	Nut, stiff, floating strip, 16 nuts	2	—	C	
28Q/6638	AS2227/404	Rivet, snap hd, $\frac{1}{8}$ " dia. x $\frac{1}{4}$ " long	34	DTD327	C	
13935	3F5198	Web, nose rib...	1	DTD610	C	
	—	RIB, No. 1, NOSE, PORTION, STARBOARD, GROUP (2F5198)				1	—		54/55
		Consisting of :—							
	12F7248	Channel, stiffening	2	DTD610		
	24F7248	Channel, stiffening	1	DTD610		
28M/10240	CL/111	Nut, stiff, thin floating anchor	2	—	C	
28M/10673	CJ/111/1	Nut, stiff, floating strip	2	—	C	
28Q/6638	AS2227/404	Rivet, snap hd, $\frac{1}{8}$ " dia. x $\frac{1}{4}$ " long	34	DTD327	C	
	4F5198	Web, nose rib	1	DTD610		

SHACKLETON Mk 2

MAIN PLANES
INNER MAIN PLANE

Ref. No.	Part No.	Description				No. off	Matl. Spec.	Cl. of St.	Plate and Illust'n No.
		1	2	3	4			M.R.	
		RIB, No. 1A, NOSE PORTION, PORT, GROUP (1F5199)				1	—		54/56
28Q/6638	AS2227/404	Consisting of:—							
	4F7248	Rivet, snap hd, 1/8" dia. x 1/4" long	29	DTD327	C		
	7F7198	Stiffener	1	DTD610			
13823	3F5199	Stiffener	2	DTD610			
		Web, nose rib...	1	DTD610	C		
		RIB, No. 1A, NOSE PORTION, STARBOARD, GROUP (2F5199)				1	—		54/57
		Consisting of:—							
28Q/6638	AS2227/404	Rivet, snap hd, 1/8" dia. x 1/4" long	29	DTD327	C		
	4F7248	Stiffener	1	DTD610			
	6F7198	Stiffener	2	DTD610			
13824	4F5199	Web, nose rib...	1	DTD610	C		
		RIB, No. 2, NOSE PORTION, PORT GROUP (1F5200)				1	—		54/58
		Consisting of:—							
28Q/6638	AS2227/404	Rivet, snap hd, 1/8" dia. x 1/4" long	29	DTD327	C		
	4F7248	Stiffener	1	DTD610			
	7F7198	Stiffener	1	DTD610			
	7F7207	Stiffener	1	DTD610			
13821	3F5200	Web, nose rib...	1	DTD610	C		
		RIB, No. 2, NOSE PORTION, STARBOARD, GROUP (2F5200)				1	—		54/59
		Consisting of:—							
28Q/6638	AS2227/404	Rivet, snap hd, 1/8" dia. x 1/4" long	29	DTD327	C		
	4F7248	Stiffener	1	DTD610			
	6F7198	Stiffener	1	DTD610			
	6F7207	Stiffener	1	DTD610			
13822	4F5200	Web, nose rib...	1	DTD610	C		
		RIB, No. 2A, NOSE PORTION, PORT, GROUP (1F6417)				1	—		54/60
		Consisting of:—							
	12F6417	Bracket, for clip	1	DTD610			
	13F6417	Bracket, for clip	1	DTD610			
28Q/6638	AS2227/404	Rivet, snap hd, 1/8" dia. x 1/4" long	27	DTD327	C		
	2F7248	Stiffener	2	DTD610			
	4F7248	Stiffener	1	DTD610			
	3F6417	Web, nose rib...	1	DTD610			
		RIB, No. 2A, NOSE PORTION, STARBOARD, GROUP (2F6417)				1	—		54/61
		Consisting of:—							
	12F6417	Bracket, for clip	1	DTD610			
	13F6417	Bracket, for clip	1	DTD610			
28Q/6638	AS2227/404	Rivet	27	DTD327	C		
	2F7248	Stiffener	2	DTD610			
	4F7248	Stiffener	1	DTD610			
	4F6417	Web, nose rib...	1	DTD610			

MAIN PLANES
INNER MAIN PLANE

Ref. No.	Part No.	Description				No. off	Matl. Spec.	Cl. of St.	Plate and Illust'n No.
		1	2	3	4			M.R.	
1441	—	RIB, No. 3, NOSE PORTION, PORT, GROUP (1F7198)				1	—	C	54/62
		Consisting of:—							
28Q/6638	AS2227/404	Rivet, snap hd, $\frac{1}{8}$ " dia. x $\frac{1}{4}$ " long	24	DTD327	C	
	4F7248	Stiffener	1	DTD610		
	7F7198	Stiffener	2	DTD610		
	3F7198	Web, nose rib...	1	DTD610		
1451	—	RIB, No. 3, NOSE PORTION, STARBOARD, GROUP (2F7198)				1	—	C	54/3
		Consisting of:—							
28Q/6638	AS2227/404	Rivet, snap hd, $\frac{1}{8}$ " dia. x $\frac{1}{4}$ " long	24	DTD327	C	
	4F7248	Stiffener	1	DTD610		
	6F7198	Stiffener	2	DTD610		
	4F7198	Web, nose rib...	1	DTD610		
1442	—	RIB, No. 3A, NOSE PORTION, PORT, GROUP (1F7199)				1	—	C	54/64
		Consisting of:—							
28Q/6638	AS2227/404	Rivet, snap hd, $\frac{1}{8}$ " dia. x $\frac{1}{4}$ " long	28	DTD327	C	
	4F7248	Stiffener	1	DTD610		
	7F7198	Stiffener	1	DTD610		
	7F7207	Stiffener	1	DTD610		
	3F7199	Web, nose rib...	1	DTD610		
1452	—	RIB, No. 3A, NOSE PORTION, STARBOARD, GROUP (2F7199)				1	—	C	54/65
		Consisting of:—							
28Q/6638	AS2227/404	Rivet, snap hd, $\frac{1}{8}$ " dia. x $\frac{1}{4}$ " long	28	DTD327	C	
	4F7248	Stiffener	1	DTD610		
	6F7198	Stiffener	1	DTD610		
	6F7207	Stiffener	1	DTD610		
	4F7199	Web, nose rib...	1	DTD610		
1443	—	RIB, No. 4, NOSE PORTION, PORT, GROUP (1F7206)				1	—	C	54/66
		Consisting of:—							
28Q/6638	AS2227/404	Rivet, snap hd, $\frac{1}{8}$ " dia. x $\frac{1}{4}$ " long	28	DTD327	C	
	4F7248	Stiffener	1	DTD610		
	7F7198	Stiffener	2	DTD610		
	3F7206	Web, nose rib...	1	DTD610		
1453	—	RIB, No. 4, NOSE PORTION, STARBOARD, GROUP (2F7206)				1	—	C	54/67
		Consisting of:—							
28Q/6638	AS2227/404	Rivet, snap hd, $\frac{1}{8}$ " dia. x $\frac{1}{4}$ " long	28	DTD327	C	
	4F7248	Stiffener	1	DTD610		
	6F7198	Stiffener	2	DTD610		
	4F7206	Web, nose rib...	1	DTD610		
1450	—	RIB, No. 4A, NOSE PORTION, PORT, GROUP (1F7201)				1	—	C	54/68
		Consisting of:—							
28Q/6638	AS2227/404	Rivet, snap hd, $\frac{1}{8}$ " dia. x $\frac{1}{4}$ " long	28	DTD327	C	
	7F7198	Stiffener	1	DTD610		
	7F7207	Stiffener	1	DTD610		
	4F7248	Stiffener	1	DTD610		
	3F7201	Web, nose rib...	1	DTD610		

SHACKLETON Mk 2

MAIN PLANES
INNER MAIN PLANE

Ref. No.	Part No.	Description				No. off	Matl. Spec.	Cl. of St.	Plate and Illust'n No.
		1	2	3	4			M.R.	
1460	—	RIB, No. 4A, NOSE PORTION, STARBOARD, GROUP (2F7201)				1	—	C	54/69
28Q/6638	AS2227/404	Consisting of:—							
	4F7248	Rivet, snap hd, 1/8" dia. x 1/4" long	28	DTD327	C	
	6F7198	Stiffener	1	L72		
	6F7207	Stiffener	1	L72		
	4F7201	Web, nose rib...	1	L72		
1444	—	RIB, No. 5, NOSE, PORTION, PORT, GROUP (1F7207)				1	—	C	54/70
28Q/6638	AS2227/404	Consisting of:—							
	4F7248	Rivet, snap hd, 1/8" dia. x 1/4" long	29	DTD327	C	
	7F7198	Stiffener	1	L72		
	7F7207	Stiffener	1	L72		
	3F7207	Web, nose rib...	1	L72		
1454	—	RIB, No. 5, NOSE PORTION, STARBOARD, GROUP (2F7207)				1	—	C	54/71
28Q/6638	AS2227/404	Consisting of:—							
	4F7248	Rivet, snap hd, 1/8" dia. x 1/4" long	29	DTD327	C	
	6F7198	Stiffener	1	L72		
	6F7207	Stiffener	1	L72		
	4F7207	Web, nose rib...	1	L72		
1445	—	RIB, No. 5A, NOSE PORTION, PORT, GROUP (1F7208)				1	—	C	54/72
28Q/6638	AS2227/404	Consisting of:—							
	4F7248	Rivet, snap hd, 1/8" dia. x 1/4" long	28	DTD327	C	
	7F7207	Stiffener	1	L72		
	3F7208	Web, nose rib...	2	L72		
						1	L72		
1455	—	RIB, No. 5A, NOSE PORTION, STARBOARD, GROUP (2F7208)				1	—	C	54/73
28Q/6638	AS2227/404	Consisting of:—							
	4F7248	Rivet, snap hd, 1/8" dia. x 1/4" long	28	DTD327	C	
	6F7207	Stiffener	1	L72		
	4F7208	Web, nose rib...	2	L72		
						1	L72		
1446	—	RIB, No. 6, NOSE PORTION, PORT, GROUP (1F7205)				1	—	C	54/74
28Q/6638	AS2227/404	Consisting of:—							
	4F7248	Rivet, snap hd, 1/8" dia. x 1/4" long	29	DTD327	C	
	7F7198	Stiffener	1	L72		
	7F7207	Stiffener	1	L72		
	3F7205	Web, nose rib...	1	L72		
1456	—	RIB, No. 6, NOSE PORTION, STARBOARD GROUP (2F7205)				1	—	C	54/75
28Q/6638	AS2227/404	Consisting of:—							
	4F7248	Rivet, snap hd, 1/8" dia. x 1/4" long	29	DTD327	C	
	6F7198	Stiffener	1	L72		
	6F7207	Stiffener	1	L72		
	4F7205	Web, nose rib...	1	L72		

MAIN PLANES
INNER MAIN PLANE

Ref. No.	Part No.	Description				No. off	Matl. Spec.	Cl. of St.	Plate and Illust'n No.
		1	2	3	4			M.R.	
1447	—	RIB, No. 6A, NOSE PORTION, PORT, GROUP (6F6709)				1	—	C	54/76
		Consisting of:—							
26EA/32499 28Q/6638	9F5209 AS2227/404 12F6709 14F7248 24F7248 40F7248 8F6709	Bracket, attachment	1	L72	C	
		Rivet, snap hd, 1/8" dia. x 1/4" long	59	DTD327	C	
		Stiffener	1	L72		
		Stiffener	1	L72		
		Stiffener	1	L72		
		Stiffener	1	L72		
		Web, nose rib...	1	L72		
1457	—	RIB, No. 6A, NOSE PORTION, STARBOARD, GROUP (7F6709)				1	—	C	54/77
		Consisting of:—							
26EA/32502 28Q/6638	10F5209 AS2227/404 12F6709 14F7248 48F7248 24F7248 9F6709	Bracket, attachment	1	L72	C	
		Rivet, snap hd, 1/8" dia. x 1/4" long	59	DTD327	C	
		Stiffener	1	L72		
		Stiffener	1	L72		
		Stiffener	1	L72		
		Stiffener	1	L72		
		Web, nose rib...	1	L72		
1448	—	RIB No. 8A, NOSE PORTION, GROUP (1F7212)				1	—	C	54/78
		Consisting of:—							
	7F5210	ANGLE SUPPORT MEMBER, GROUP				1	L72		
	6F7212	Angle, stiffening 5.75" long	1	L72		
	18F7212	Angle, stiffening 3.75" long	1	L72		
	10F5209	Bracket, attachment 18G	1	L72		
	6F7212	Angle, stiffening 5.75" long	1	L72		
	10F5210	Bracket, attachment 18G	1	L72		
	8F7212	Bracket, for pipe clip 18G	1	L72		
	24F7248	Channel, 4.25" long	1	L72		
28Q/6638 28Q/10412	AS2227/404 AS2230/404 9F5210	Rivet, snap hd. 1/8" dia x 1/4" long	37	DTD327	C	
		Rivet, csk.hd. 1/8" dia. x 1/4" long	2	DTD327	C	
		Stiffener, corner	1	L72		
1458	—	RIB No. 8A, NOSE PORTION, STARBOARD, GROUP (2F7212)				1	—	C	54/79
		Consisting of:—							
	8F5210	ANGLE SUPPORT MEMBER, GROUP				1	L72		
	7F7212	Angle, stiffening 5.75" long	1	L72		
	5F7212	Angle, stiffening 20G	1	L72		
	8F7212	Bracket, for pipe clip	1	L72		
	9F5209	Bracket, attachment	1	L72		
	13F5210	Bracket, attachment	1	L72		
	24F7248	Channel, 4.25" long	1	L72		
28Q/6638 28Q/10412	AS2227/404 AS2230/404 9F5210	Rivet, snap hd. 1 1/8" dia. x 1/4" long	47	DTD327		
		Rivet, csk.hd. 1 1/8" dia. x 1/4" long	2	DTD327		
		Stiffener, corner	1	L72		

MAIN PLANES
INNER MAIN PLANE

Ref. No.	Part No.	Description				No. off	Matl. Spec.	Cl. of St.	Plate and Illust'n No.
		1	2	3	4			M.R.	
	—	RIB, No. 9, NOSE PORTION, PORT, GROUP (1F6711)				1	—		54/80
28Q/6638	AS2227/404 10F7248 3F6711	Consisting of:— Rivet, snap hd, $\frac{1}{8}$ " dia. x $\frac{1}{4}$ " long				18	DTD327	C	
		Stiffener				2	L72		
		Web, nose rib... ..				1	L72		
	—	RIB, No. 9, NOSE PORTION, STARBOARD, GROUP (2F6711)				1	—	C	54/81
28Q/6638	AS2227/404 10F7248 4F6711	Consisting of:— Rivet, snap hd, $\frac{1}{8}$ " dia. x $\frac{1}{4}$ " long				18	DTD327	C	
		Stiffener				2	L72		
		Web, nose rib... ..				1	L72		
	—	RIB, No. 9A, NOSE PORTION, PORT, GROUP (1F6712)				1	—		54/82
28Q/6638	19F6170 AS2227/404 10F7248 3F6712	Consisting of:— Bracket, attachment				1	L72		
		Rivet, snap hd, $\frac{1}{8}$ " dia. x $\frac{1}{4}$ " long				17	DTD327	C	
		Stiffener				2	L72		
		Web, nose rib... ..				1	L72		
7509	2F6712	RIB, No. 9A, NOSE PORTION, STARBOARD, GROUP				1	—	C	54/83
28Q/6638	19F6170 AS2227/404 10F7248 4F6712	Consisting of:— Bracket, attachment				1	L72		
		Rivet, snap hd, $\frac{1}{8}$ " dia. x $\frac{1}{4}$ " long				17	DTD327	C	
		Stiffener				2	L72		
		Web, nose rib... ..				1	L72		
	—	RIB, No. 10, NOSE PORTION, PORT, GROUP (1F6713)				1	—		54/84
28Q/6638	AS2227/404 10F7248 3F6713	Consisting of:— Rivet, snap hd, $\frac{1}{8}$ " dia. x $\frac{1}{4}$ " long				18	DTD327	C	
		Stiffener				2	L72		
		Web, nose rib... ..				1	L72		
	—	RIB, No. 10, NOSE PORTION, STARBOARD, GROUP (2F6713)				1	—		54/85
28Q/6638	AS2227/404 10F7248 4F6713	Consisting of:— Rivet, snap hd, $\frac{1}{8}$ " dia. x $\frac{1}{4}$ " long				18	DTD327	C	
		Stiffener				2	L72		
		Web, nose rib... ..				1	L72		
	—	RIB, No. 10A, NOSE PORTION, PORT, GROUP (1F6714)				1	—		54/86
28Q/6638	AS2227/404 6F7248 24F7248 3F6714	Consisting of:— Rivet, snap hd, $\frac{1}{8}$ " dia. x $\frac{1}{4}$ " long				20	DTD327	C	
		Stiffener				1	L72		
		Stiffener				1	L72		
		Web, nose rib... ..				1	L72		

MAIN PLANES
INNER MAIN PLANES

Ref. No.	Part No.	Description				No. off	Matl. Spec.	Cl. of St.	Plate and Illust'n No.
		1	2	3	4			M.R.	
	—	RIB, No. 10A, NOSE PORTION, STARBOARD, GROUP (2F6714)				1	—		54/87
		Consisting of:—							
28Q/6638	AS2227/404 6F7248 24F7248 4F6714	Rivet, snap hd, $\frac{1}{8}$ " dia. x $\frac{1}{4}$ " long	20	DTD327	C	
		Stiffener	1	L72		
		Stiffener	1	L72		
		Web, nose rib...	1	L72		
	—	RIB, No. 11, NOSE PORTION, PORT, GROUP (1F6715)				1	—		54/88
		Consisting of:—							
28Q/6638	AS2227/404 10F7248 3F6715	Rivet, snap hd, $\frac{1}{8}$ " dia. x $\frac{1}{4}$ " long	18	DTD327	C	
		Stiffener	2	L72		
		Web, nose rib...	1	L72		
	—	RIB, No. 11, NOSE PORTION, STARBOARD, GROUP (2F6715)				1	—		54/89
		Consisting of:—							
28Q/6638	AS2227/404 10F7248 4F6715	Rivet, snap hd, $\frac{1}{8}$ " dia. x $\frac{1}{4}$ " long	18	DTD327	C	
		Stiffener	2	L72		
		Web, nose rib...	1	L72		
	—	RIB, No. 11A, NOSE PORTION, PORT, GROUP (1F6716)				1	—		54/90
		Consisting of:—							
28Q/6638	AS2227/404 10F7248 3F6716	Rivet, snap hd, $\frac{1}{8}$ " dia. x $\frac{1}{4}$ " long	16	DTD327	C	
		Stiffener	2	L72		
		Web, nose rib...	1	L72		
	—	RIB, No. 11A, NOSE PORTION, STARBOARD, GROUP (2F6716)				1	—		54/91
		Consisting of:—							
28Q/6638	AS2227/404 10F7248 4F6716	Rivet, snap hd, $\frac{1}{8}$ " dia. x $\frac{1}{4}$ " long	16	DTD327	C	
		Stiffener	2	L72		
		Web, nose rib...	1	L72		
	—	RIB, No. 12, NOSE PORTION, PORT, GROUP (1F6717)				1	—		54/92
		Consisting of:—							
28Q/6638	AS2227/404 10F7248 3F6717	Rivet, snap hd, $\frac{1}{8}$ " dia. x $\frac{1}{4}$ " long	17	DTD327	C	
		Stiffener	2	L72		
		Web, nose rib...	1	L72		
	—	RIB, No. 12, NOSE PORTION, STARBOARD, GROUP (2F6717)				1	—		54/93
		Consisting of:—							
28Q/6638	AS2227/404 10F7248 4F6717	Rivet, snap hd, $\frac{1}{8}$ " dia. x $\frac{1}{4}$ " long	17	DTD327	C	
		Stiffener	2	L72		
		Web, nose rib...	1	L72		
	—	RIB, No. 12A, NOSE PORTION, PORT, GROUP (1F6718)				1	—		54/94
		Consisting of:—							
28Q/6638	AS2227/404 10F7248 3F6718	Rivet, snap hd, $\frac{1}{8}$ " dia. x $\frac{1}{4}$ " long	17	DTD327	C	
		Stiffener	2	L72		
		Web, nose rib...	1	L72		

SHACKLETON Mk. 2

MAIN PLANES
INNER MAIN PLANE

Ref. No.	Part No.	Description				No. off	Matl. Spec.	Cl. of St.	Plate and Illust'n No.
		1	2	3	4			M.R.	
	—	RIB, No. 12A, NOSE PORTION, STARBOARD, GROUP (2F6718)				1	—		54/95
		Consisting of:—							
28Q/6638	AS2227/404	Rivet, snap hd, $\frac{1}{8}$ " dia. x $\frac{1}{4}$ " long	17	DTD327	C	
	10F7248	Stiffener	2	DTD610		
	4F6718	Web, nose rib...	1	DTD610		
	—	RIB, No. 13, NOSE PORTION, PORT, GROUP (1F6719)				1	—		54/96
		Consisting of:—							
28Q/6638	AS2227/404	Rivet, snap hd, $\frac{1}{8}$ " dia. x $\frac{1}{4}$ " long	15	DTD327	C	
	4F7248	Stiffener	1	DTD610		
	10F7248	Stiffener	1	DTD610		
	3F6719	Web, nose rib...	1	DTD610		
	—	RIB, No. 13, NOSE PORTION, STARBOARD, GROUP (2F6719)				1	—		54/97
		Consisting of:—							
28Q/6638	AS2227/404	Rivet, snap hd, $\frac{1}{8}$ " dia. x $\frac{1}{4}$ " long	15	DTD327	C	
	4F7248	Stiffener	1	DTD610		
	10F7248	Stiffener	1	DTD610		
	4F6719	Web, nose rib...	1	DTD610		
	—	RIB, No. 13A, NOSE PORTION, PORT, GROUP (1F6760)				1	—		54/98
		Consisting of:—							
28Q/6638	AS2227/404	Rivet, snap hd, $\frac{1}{8}$ " dia. x $\frac{1}{4}$ " long	15	DTD327	C	
	4F7248	Stiffener	1	DTD610		
	10F7248	Stiffener	1	DTD610		
	3F6760	Web, nose rib...	1	DTD610		
	—	RIB, No. 13A, NOSE PORTION, STARBOARD, GROUP (2F6760)				1	—		54/99
		Consisting of:—							
28Q/6638	AS2227/404	Rivet, snap hd, $\frac{1}{8}$ " dia. x $\frac{1}{4}$ " long	15	DTD327	C	
	4F7248	Stiffener	1	DTD610		
	10F7248	Stiffener	1	DTD610		
	4F6760	Web, nose rib...	1	DTD610		
	—	RIB, No. 14, NOSE PORTION, PORT, GROUP (1F6721)				1	—		54/100
		Consisting of:—							
28Q/6638	AS2227/404	Rivet, snap hd, $\frac{1}{8}$ " dia. x $\frac{1}{4}$ " long	15	DTD327	C	
	4F7248	Stiffener	2	DTD610		
	3F6721	Web, nose rib...	1	DTD610		
	—	RIB, No. 14, NOSE PORTION, STARBOARD, GROUP (2F6721)				1	—		54/101
		Consisting of:—							
28Q/6638	AS2227/404	Rivet, snap hd, $\frac{1}{8}$ " dia. x $\frac{1}{4}$ " long	15	DTD327	C	
	4F7248	Stiffener	2	DTD610		
	4F6721	Web, nose rib...	1	DTD610		

MAIN PLANES
INNER MAIN PLANE

Ref. No.	Part No.	Description				No. off	Matl. Spec.	Cl. of St. M.R.	Plate and Illust'n No.
		1	2	3	4				
	—	RIB, No. 14A, NOSE PORTION, PORT, GROUP (1F6722)				1	—		54/102
		Consisting of:—							
28Q/6638	AS2227/404	Rivet, snap hd, 1/8" dia. x 1/4" long ...				14	DTD327	C	
	4F7248	Stiffener ...				2	DTD610		
	3F6722	Web, nose rib...				1	DTD610		
	—	RIB, No. 14A, NOSE PORTION, STARBOARD, GROUP (2F6722)				1	—		54/103
		Consisting of:—							
28Q/6638	AS2227/404	Rivet, snap hd, 1/8" dia. x 1/4" long ...				14	DTD327	C	
	4F7248	Stiffener ...				2	DTD610		
	4F6722	Web, nose rib...				1	DTD610		
	—	RIB, No. 14B, NOSE PORTION, PORT, GROUP (1F6723)				1	—		54/104
		Consisting of:—							
28Q/6638	AS2227/404	Rivet, snap hd, 1/8" dia. x 1/4" long ...				14	DTD327	C	
	4F7248	Stiffener ...				2	DTD610		
	3F6723	Web, nose rib...				1	DTD610		
	—	RIB, No. 14B, NOSE PORTION, STARBOARD, GROUP (2F6723)				1	—		54/105
		Consisting of:—							
28Q/6638	AS2227/404	Rivet, snap hd, 1/8" dia. x 1/4" long ...				14	DTD327	C	
	4F7248	Stiffener ...				2	DTD610		
	4F6723	Web, nose rib...				1	DTD610		
	—	RIB, No. 15, NOSE PORTION, PORT, GROUP (1F6724)				1	—		54/106
		Consisting of:—							
28Q/6638	AS2227/404	Rivet, snap hd, 1/8" dia. x 1/4" long ...				14	DTD327	C	
	4F7248	Stiffener ...				2	DTD610		
	3F6724	Web, nose rib...				1	DTD610		
	—	RIB, No. 15, NOSE PORTION, STARBOARD, GROUP (2F6724)				1	—		54/107
		Consisting of:—							
28Q/6638	AS2227/404	Rivet, snap hd, 1/8" dia. x 1/4" long ...				14	DTD327	C	
	4F7248	Stiffener ...				2	DTD610		
	4F6724	Web, nose rib...				1	DTD610		
	—	RIB, No. 15A, NOSE PORTION, PORT, GROUP (1F6725)				1	—		54/108
		Consisting of:—							
28Q/6638	AS2227/404	Rivet, snap hd, 1/8" dia. x 1/4" long ...				19	DTD327	C	
	4F7248	Stiffener ...				1	DTD610		
	33F7248	Stiffener ...				1	DTD610		
	3F6725	Web, nose rib...				1	DTD610		

SHACKLETON Mk 2

MAIN PLANES
INNER MAIN PLANE

Ref. No.	Part No.	Description				No. off	Matl. Spec.	Cl. of St.	Plate and Illust'n No.
		1	2	3	4			M.R.	
28Q/6638	AS2227/404 4F7248 32F7248 4F6725	RIB, No. 15A, NOSE PORTION, STARBOARD, GROUP (2F6725)				1	—		54/109
		Consisting of:—							
		Rivet, snap hd, 1/8" dia. x 1/4" long	19	DTD327	A	
		Stiffener	1	DTD610		
28Q/6638	AS2227/404 4F7248 10F7248 3F6726	RIB, No. 15B, NOSE PORTION, PORT, GROUP (1F6726)				1	—		54/110
		Consisting of:—							
		Bracket...	2	DTD610	C	
		Rivet, snap hd, 1/8" dia. x 1/4" long	20	DTD327		
28Q/6638	AS2227/404 4F7248 10F7248 4F6726	RIB, No. 15B, NOSE PORTION, STARBOARD, GROUP (2F6726)				1	—		54/111
		Consisting of:—							
		Bracket...	2	DTD610	C	
		Rivet, snap hd, 1/8" dia. x 1/4" long	20	DTD327		
28Q/6638	AS2227/404 4F7248 5F6727 3F6727	RIB, No. 16, NOSE PORTION, PORT, GROUP (1F6727)				1	—		54/112
		Consisting of:—							
		Rivet, snap hd, 1/8" dia. x 1/4" long	18	DTD327	C	
		Stiffener	1	DTD610		
28Q/6638	AS2227/404 4F7248 6F6727 4F6727	RIB, No. 16, NOSE PORTION, STARBOARD, GROUP (2F6727)				1	—		54/113
		Consisting of:—							
		Rivet, snap hd, 1/8" dia. x 1/4" long	18	DTD327	C	
		Stiffener	1	DTD610		
28Q/6638	AS2227/404 4F7248 3F6728	RIB, No. 16A, NOSE PORTION, PORT, GROUP (1F6728)				1	—		54/114
		Consisting of:—							
		Rivet, snap hd, 1/8" dia. x 1/4" long	14	DTD327	C	
		Stiffener	2	DTD610		
28Q/6638	AS2227/404 4F7248 4F6728	RIB, No. 16A, NOSE PORTION, STARBOARD, GROUP (2F6728)				1	—		54/115
		Consisting of:—							
		Rivet, snap hd, 1/8" dia. x 1/4" long	14	DTD327	C	
		Stiffener	2	DTD610		

MAIN PLANES
INNER MAIN PLANE

Ref. No.	Part No.	Description				No. off	Matl. Spec.	Cl. of St.	Plate and Illust'n No.
		1	2	3	4			M.R.	
	—	RIB, No. 16B, NOSE PORTION, PORT, GROUP (1F6729)				1	—		54/116
		Consisting of:—							
28Q/6638	AS2227/404	Rivet, snap hd, $\frac{1}{8}$ " dia. x $\frac{1}{4}$ " long	19	DTD327		
	4F7248	Stiffener	1	DTD610		
	5F6727	Stiffener	1	DTD610		
	3F6729	Web, nose rib...	1	DTD610		
	—	RIB, No. 16B, NOSE PORTION, STARBOARD, GROUP (2F6729)				1	—		54/117
		Consisting of:—							
28Q/6638	AS2227/404	Rivet, snap hd, $\frac{1}{8}$ " dia. x $\frac{1}{4}$ " long	19	DTD327	C	
	4F7248	Stiffener	1	DTD610		
	6F6727	Stiffener	1	DTD610		
	4F6729	Web, nose rib	1	DTD610		
	—	RIB, No. 17, NOSE PORTION, PORT, GROUP (1F6730)				1	—		54/118
		Consisting of:—							
28Q/6638	AS2227/404	Rivet, snap hd, $\frac{1}{8}$ " dia. x $\frac{1}{4}$ " long	14	DTD327	C	
	4F7248	Stiffener	1	DTD610		
	3F6730	Web, nose rib...	1	DTD610		
	—	RIB, No. 17, NOSE PORTION, STARBOARD, GROUP (2F6730)				1	—		54/119
		Consisting of:—							
28Q/6638	AS2227/404	Rivet, snap hd, $\frac{1}{8}$ " dia. x $\frac{1}{4}$ " long	14	DTD327	C	
	4F7248	Stiffener	2	DTD610		
	4F6730	Web, nose rib...	1	DTD610		
	—	RIB, No. 17A, NOSE PORTION, PORT, GROUP (1F6731)				1	—		54/120
		Consisting of:—							
28Q/6638	AS2227/404	Rivet, snap hd, $\frac{1}{8}$ " dia. x $\frac{1}{4}$ " long	14	DTD327	C	
	4F7248	Stiffener	2	DTD610		
	3F6731	Web, nose rib...	1	DTD610		
	—	RIB, No. 17A, NOSE PORTION, STARBOARD, GROUP (2F6731)				1	—		54/121
		Consisting of:—							
28Q/6638	AS2227/404	Rivet, snap hd, $\frac{1}{8}$ " dia. x $\frac{1}{4}$ " long	14	DTD327	C	
	4F7248	Stiffener	2	DTD610		
	4F6731	Web, nose rib...	1	DTD610		

SHACKLETON Mk 2

MAIN PLANES
INNER MAIN PLANE

Ref. No.	Part No.	Description				No. off	Matl. Spec.	Cl. of St. M.R.	Plate and Illust'n No.
		1	2	3	4				
	—	RIB, No. 17B, NOSE PORTION, PORT, GROUP (1F6732)				1	—		54/122
28Q/6638	AS2227/404 4F7248 3F6732	Consisting of :— Rivet , snap hd, 1/8" dia. x 1/4" long				14	DTD327	C	
		Stiffener				2	DTD610		
		Web , nose rib... ..				1	DTD610		
	—	RIB, No. 17B, NOSE PORTION, STARBOARD, GROUP (2F6732)				1	—		54/123
28Q/6638	AS2227/404 4F7248 4F6732	Consisting of :— Rivet , snap hd, 1/8" dia. x 1/4" long				14	DTD327	C	
		Stiffener				2	DTD610		
		Web , nose rib... ..				1	DTD610		
1449	—	RIB, No. 18, NOSE PORTION, PORT, GROUP (1F7228)				1	—	C	54/124
26EA/32507 26EA/32508	8F5232 10F5232	Consisting of : Angle , top				1	DTD610	C	
		Angle , bottom				1	DTD610	C	
	5F7228	NOSE-PIECE, PORT, GROUP				1			
28M/12336	AGS2015/C/ 11/0-8"/13	Nut , floating strip x .8" pitch x 13 nuts ...				1	—	C	
28M/12336	AGS2015/C/ 11/0-8"/12	Nut , floating strip x .8" pitch x 12 nuts ...				1	—	C	
28Q/6638	AS2227/404 4F7248 3F7228	Rivet , snap hd, 1/8" dia. x 1/4" long				58	DTD327	C	
		Stiffener				1	DTD610		
		Web , nose rib... ..				1	DTD610		
1459	—	RIB, No. 18, NOSE PORTION, STARBOARD, GROUP (2F7228)				1	—	C	54/125
26EA/32510 26EA/52511	9F5232 11F5232	Consisting of :— Angle , top				1	DTD610	C	
		Angle , bottom				1	DTD610	C	
	6F7228	NOSE-PIECE, STARBOARD, GROUP				1	—		
28M/12336	AGS2015/C/ 11/0-8"/13	Nut , floating strip x .8" pitch x 13 nuts ...				1	—	C	
28M/12336	AGS2015/C/ 11/0-8"/12	Nut , floating strip x .8" pitch x 12 nuts ...				1	—	C	
28Q/6638	AS2227/404 4F7248 4F7228	Rivet , snap hd, 1/8" dia. x 1/4" long				69	DTD327	C	
		Stiffener				1	DTD610		
		Web , nose rib... ..				1	DTD610		

MAIN PLANES
INNER MAIN PLANE

Ref. No.	Part No.	Description				No. off	Matl. Spec.	Cl. of St.	Plate and Illust'n No.
		1	2	3	4			M.R.	
		RIB, No. 7A, CENTRE PORTION (F5664)							54/126
		Spares for :—							
		(Some or all of the following items may be required for repairs if there is any damage at the engine subframe attachment point, rear spar)							
28D/12513	A25/2C	Bolt , hex.hd, 2 BA x .65" long, attachment of reinforcing channel				12	—	C	
28D/12520	A25/4E	Bolt , hex.hd, $\frac{1}{4}$ " BSF x .9" long attachment of packing piece to channel				4	—	C	
28D/12549	A25/20E	Bolt , hex.hd, $\frac{1}{4}$ " BSF x 2.50" long attachment of stiffening bracket to rib and boom				18	—	C	
28D/12550	A1/22E	Bolt , hex.hd, $\frac{1}{4}$ " BSF x 2.70" long attachment of reinforcing channel to rib				6	—	C	
	58F5664	Bracket , stiffening on rib web LH ...				1	DTD610		
	59F5664	Bracket , stiffening on rib web RH ...				1	DTD610		
	21F5664	Channel , reinforcing, LH ...				1	DTD610		
	22F5664	Channel , reinforcing, RH ...				1	DTD610		
28M/5316	A16Y/CP	Nut , 2 BA ...				12	—	C	
28M/756	A16Y/EP	Nut , $\frac{1}{4}$ " BSF ...				30	—	C	
	8F5240	Packing ...				2	S3		
28Q/6639	AS2227/405	Rivet , snap hd, $\frac{1}{8}$ " dia. x $\frac{5}{16}$ " long ...				46	—	C	
28Q/11236	AS2227/605	Rivet , snap hd, $\frac{3}{16}$ " x $\frac{5}{16}$ " long ...				40	—	C	
28Q/10405	AS2227/607	Rivet , snap hd, $\frac{3}{16}$ " dia. x $\frac{7}{16}$ " long ...				14	—	C	
	24.O.5664	Tube , distance, $\frac{3}{8}$ " o/d x 17G x 2" long ...				7	—	C	
28W/12252	SP13/C	Washer , 2 BA ...				12	—	C	
28W/12253	SP13/E	Washer , $\frac{1}{4}$ " BSF ...				28	—	C	

MAIN PLANES
INNER MAIN PLANE

Ref. No.	Part No.	Description				No. off	Matl. Spec.	Cl. of St.	Plate and Illust'n No.
		1	2	3	4			M.R.	
		SKINNING, BOTTOM, PORT AND STARBOARD (1&2F8337)							
		Spares for :—							
		DOOR, ACCESS, TO DE-ICING CONNECTIONS, PORT AND STARBOARD (1&2F6309)							
		Spares for :—							
709	3F6309					1	L72	M/C	54/127
710	4F6309					1	L72	M/C	54/128
		DOOR, ACCESS TO No. 3 TANK SUMP, PORT AND STARBOARD (1&4F6789)							
		Spares for :—							
1128	2F6789					1	—	M/C	54/129
1129	3F6789					1	—	M/C	54/130
		Spares for :—							
	1SS3918					1	—		54/131
		Consisting of :—							
26DD/25270	1SS3879					1	—	C	54/21
		Consisting of :—							
	1SS3881					1	—		
	1SS3882					1	—		
	1SS3880					1	—		
28P/1007947	SP9/A3					1	—		
28Q/1919	AS455/303					2	—	C	
28Q/2020	A2455/420					2	MS	C	
2945	1SS4041					2	MS	C	
	3SS3888					1	—	C	
						2	—	C	
5011	7SS3919					1	—	C	
3255	1SS3928					1	—	C	
	3SS3928					1	—	C	35/146
28Q/6619	AS2229/303					6	—	C	
28Q/6675	AS2229/304					5	—	C	
13003	4SS3158					12	S1	C	54/23
		Screw, csk.hd, 2 BA x 1/2" long attachment of access door							
	1F6754					1	—	C	
7043	2F6754					1	—	C	
		DOOR, ACCESS TO NITROGEN VALVES, PORT, GROUP							
		DOOR, ACCESS TO NITROGEN VALVES, STARBOARD, GROUP							
		Spares for :—							
13003	3F6754					1	L72		54/132
	4SS3158					8	S1	C	54/23
		Screw, csk.hd, 2 BA x 1/2" long							

MAIN PLANES
INNER MAIN PLANE

Ref. No.	Part No.	Description				No. off	Matl. Spec.	Cl. of St.	Plate and Illust'n No.
		1	2	3	4			M.R.	
		SKINNING, BOTTOM, PORT & STARBOARD (1&2F8337) (cont'd)							
		DOORS, ACCESS TO FUEL PUMP, No. 2 TANK (F8209) Spares for :—							
28D/10764	AS1248/1/2B			Bolt, mush.hd, 4 BA x 0.40" long ...	10	—	C		
7064	4F8209			DOOR, ACCESS, GROUP ...	1	—	C	54/133	
		DOOR, ACCESS TO TANK STRAPS, PORT AND STARBOARD (1&2F5723) Spares for :—							
711	24F5723			Door, access ...	2	L72	C	54/134	
13003	4SS3158			Screw, csk.hd, 2 BA x 1/2" long ...	24	S1	C	54/23	
1916	18F5773			DOOR, ACCESS, TO DE-ICING PIPE CONNECTION, GROUP	6	—	C	54/135	
				Duct, ventilating ...	1	L72			
716	184F5773 5F6373			Panel, access to controls in leading edge, port	1	L72	M/C	54/136	
717	6F6373			Panel, access to controls in leading edge, starboard	1	L72	M/C	54/137	
	SS3827			Screw, Parker-Kalon No. 7, 120° hd. ...	1608	—	M/C		
				DOOR, ACCESS TO No. 2 TANK, DRAIN (7SS3926)	1	—		54/138	
				Consisting of :—					
26DD/25270	1SS3879			CATCH, MECHANISM, GROUP ... Consisting of :—	1	—	C	54/21	
	1SS3881			Catch, press ...	1	—			
	1SS3882			Catch ...	1	—			
	1SS3880			Frame ...	1	—			
28P/1007947	SP9/A3			Pin, split, 1/32" dia. ...	2	—	C		
28Q/1919	AS455/303			Rivet, snap hd, 3/32" dia. x 3/16" long ...	2	—	C		
28Q/2020	AS455/420			Rivet, snap hd, 1/8" dia. x 1/4" long ...	2	—	C		
2945	1SS4041			Spring ...	1	—			
	3SS3888			Washer, 6 BA ...	2	—	C		
	7SS3929			Door, access plate... ..	1	—			
3255	1SS3928			Hinge, door	1	—	C	35/146	
	3SS3928			Packing, hinge	1	—			
28Q/6675	AS2229/304			Rivet, csk.hd, 90°, 3/32" dia. x 1/4" long...	6	—	C		
28Q/6676	AS2229/305			Rivet, csk.hd, 90°, 3/32" dia. x 5/16" long ...	5	—	C		
	1SS3927			Stop, door	1	—			
	20SS3221			DOOR, ACCESS TO TANK STRAP AND WATER METHONAL PIPE CONNECTION, GROUP	3	—		54/26	

SHACKLETON Mk. 2

MAIN PLANES
INNER MAIN PLANES

Ref. No.	Part No.	Description				No. off	Matl. Spec.	Cl. of St.	Plate and Illust'n No.
		1	2	3	4			M.R.	
		SKINNING, TOP, PORT AND STARBOARD (18&19F6372)							
		Spares for :—							
		DOOR, ACCESS TO TANK SUPPORT STRAPS BETWEEN RIBS 9-9A AND 11-11A, PORT AND STARBOARD (1&2F6221)							
		Spares for :—							
13123	17SS3221					2	L72	C	54/22
13003	4SS3158					12	S1	C	54/23
		DOOR, ACCESS TO TANK SUPPORT STRAPS, PORT AND STARBOARD (1&2F6226)							
		Spares for :—							
13123	17SS3221					2	L72	C	54/22
13911	20SS3221					1	L72	C	54/26
13003	4SS3158					18	S1	C	54/23
6841	3F5761	DOOR, PLATE, FOR VAPOUR VENT, FLAME SWITCHES, GROUP				1	—	C	54/139
		DOOR, ACCESS TO FUEL GAUGE, No. 3 TANK (1F5895)							
		Spares for :—							
708	2F5895					1	—	C	54/140
13003	4SS3158					6	S1	C	54/23
7557	1F6374	DOOR, ACCESS TO FILLER CAP AND VENT ELBOW, No. 4 TANK, PORT, GROUP				1	—	B	
	2F6374	DOOR, ACCESS TO FILLER CAP AND VENT ELBOW, No. 4 TANK, STARBOARD, GROUP				1	—		
		Spares for :—							
28D/8484	AS1885/1C					30	MS	C	
703	10F6374	DOOR, ACCESS, PORT, GROUP...				1	—	M/C	54/141
704	11F6374	DOOR, ACCESS, STARBOARD, GROUP				1	—	M/C	54/142
		Spares for :—							
705	15F6374	DOOR, ACCESS, GROUP				1	—	C	54/143
4801	16F6374	Washer				1	Langite	C	54/144
	16F6372	Door, access to pipe joints				1	L72		54/145
13911	20SS3221	Door, inspection, to pipe joints				1	L72	C	54/26
13124	30SS3221	Door, inspection, to pipe clips				5	L72	C	54/146
3131	11F5772	Duct, ventilating				1	L72		54/147
13285	3F4033	Plug, slinging				4	L1	C	54/148
13286	73F4687	Plug, slinging engine				2	L1	C	54/149
13003	4SS3158	Screw, csk.hd, 2 BA x 1/2" long				36	S1	C	54/23
	SS3827	Screw, Parker Kalon, No. 7, 120° head				1748	—		

MAIN PLANES
INNER MAIN PLANE

Ref. No.	Part No.	Description				No. off	Matl. Spec.	Cl. of St.	Plate and Illust'n No.
		1	2	3	4			M.R.	
		SPAR, FRONT, PORT AND STARBOARD (13 & 14F6313)							
		Spares for :—							
26EA/141	14F3982	Bolt , hex. hd, $\frac{7}{16}$ " dia. x 1.9" for mooring ring				4	S2 or S11	C	54/150
	41F5142	Bolt , $\frac{7}{16}$ " dia. for mooring ring bracket (Pre-Mod. 860)				1	S11		
	44F5142	Bolt , $\frac{5}{16}$ " dia. for mooring ring bracket (Pre-Mod. 860)				1	S11		54/152
	45F5142	Bolt , $\frac{5}{16}$ " dia. for mooring ring bracket (Pre-Mod. 860)				1	S11		54/153
	1SS4749	Bolt , $\frac{7}{16}$ " dia. for mooring ring bracket (Mod. 860)				2	S94		54/151
	1SS4784	Bolt , $\frac{5}{16}$ " dia. for mooring ring bracket (Mod. 860)				1	S94		54/152
	1SS4785	Bolt , $\frac{5}{16}$ " dia. for mooring ring bracket ...				1	S94		54/153
5572	46F6313	Bolt , special, front spar, joint wing boom, $1\frac{1}{2}$ " dia. x $5\frac{1}{2}$ " long				2	S99	C	
	6F6313	Bracket , for mooring ring attachment, inboard, port				1	S11		54/154
	4F6313	Bracket , mooring attachment, inboard, port				1	S11		54/155
	7F6313	Bracket , mooring ring attachment, inboard, starboard				1	S11		54/156
	5F6313	Bracket , mooring ring attachment, inboard, starboard				1	S11		54/157
	37F5142	Bracket , mooring ring attachment, outboard, port				1	S11		54/158
	39F5142	Bracket , mooring ring attachment, outboard, port				1	S11		54/159
	38F5142	Bracket , mooring ring attachment, outboard, starboard				1	S11		54/160
	40F5142	Bracket , mooring ring attachment, outboard, starboard				1	S11		54/161
	50F5142	Bracket , slinging, port				1	L40		54/162
	51F5142	Bracket , slinging, starboard				1	L40		54/163
	52F5142	Bracket , slinging, port				1	L40		54/164
	53F5142	Bracket , slinging, starboard				1	L40		54/165
7001	12F6313	Bush , joint pin, top and bottom boom (Pre-Mod. 599)				2	DTD331 or 582	C	54/166
5574	131F6313	Bush , joint pin, top and bottom boom (Mod. 599) (Pre-Mod. 701)				2	S99 or T60	C	
	141F6313	Bush , joint pin, top and bottom boom (Mod. 701)				2	S99 or T60	C	
3346	1F5124	CHANNEL, MOUNTING, ENGINE SUB-FRAME, RH, PORT, GROUP				1	—	C	54/167
3347	1F5131	CHANNEL, MOUNTING, ENGINE SUB-FRAME, LH, PORT, GROUP				1	—	C	54/168
26EA/33491	2F5124	CHANNEL, MOUNTING, ENGINE SUB-FRAME, LH, STARBOARD, GROUP				1	—	C	54/169

MAIN PLANES
INNER MAIN PLANE

Ref. No.	Part No.					Description	No. off	Matl. Spec.	Cl. of St.	Plate and Illust'n No.
		1	2	3	4				M.R.	
3348	2F5131					CHANNEL, MOUNTING, ENGINE SUB-FRAME, RH, STARBOARD, GROUP	1	—	C	54/170
4945	20F6313					Plate , jointing, outer wing to centre section, port (undrilled one side)	1	DTD546	C	54/171
4946	21F6313					Plate , jointing, outer wing to centre section, starboard (undrilled one side)	1	DTD546	C	54/172
26EA/345	9F5142					Ring , mooring, outboard	1	S11	C	54/173
	10F5142					Ring , mooring, inboard	1	S11	C	54/174
	6SS3115					Washer , web joint plate bolt	9	L3 or L1	C	54/175
						SPAR, REAR, PORT AND STARBOARD (1&2F5749)				
						Spares for :—				
7081	32F5143					Bracket , slinging	2	L40		54/176
	33F5143					Bracket , slinging, port	1	L40		54/177
	34F5143					Bracket , slinging, starboard	1	L40		54/178
	3F5749					Bush , joint pin, top and bottom (Pre-Mod. 599)	2	DTD331	C	54/179
5564	18F6379					Bush , joint pin, top and bottom (Mod. 599) (Pre-Mod. 701)	2	or 582 S99	C	
4947	22F6379					Bush , joint pin top and bottom (Mod. 701)	2	S99 or T60		
	5F5749					Plate , web joint, outer wing to centre section (undrilled one side)	1	DTD546	C	54/180
13018	9F3564					Washer , joint plate bolts	12	L1	C	54/181
	226F5069					TUBE, MANIFOLD DE-ICING, AT NOSE RIB 2A, PORT, GROUP (Mod. 643)	1	DTD323A		66/23
	231Z5069					TUBE, MANIFOLD DE-ICING, AT NOSE RIB 9A, PORT, GROUP (Mod. 643)	1	DTD323A		66/232
	227F5069					TUBE, MANIFOLD DE-ICING, AT NOSE RIB 2A, STARBOARD, GROUP (Mod. 643)	1	DTD323A		66/231
	232Z5069					TUBE, MANIFOLD DE-ICING, AT NOSE RIB 9A, STARBOARD, GROUP (Mod. 643)	1	DTD323A		66/233
	223F5069					TUBE, MANIFOLD DE-ICING, AT NOSE RIB 15B, PORT, GROUP (Mod. 643)	1	DTD323A		66/234
	230F5069					TUBE, MANIFOLD DE-ICING, AT NOSE RIB 15B, STARBOARD, GROUP (Mod. 643)	1	DTD323A		66/235
						(See Services—De-icing for the above tubes)				
						VENT, VAPOUR, No. 4 TANK (1&2P2436)				
						Spares for :—				
5F/120	AGS/1661/J					Clip , for pipe	2	—	C	54/182
	42P2436					Clip , attachment of vent pipe to Rib No. 17b	2	—		
32C/159	11P2436					Hose , 1 3/4" i/d x 2 1/2" long	1	BSS6F7	C	54/183
7411	54P2436					Pipe , vent, port (Mod. 643)	1	DTD323A	C	54/184
7412	55P2436					Pipe , vent, starboard (Mod. 643)	1	DTD323A	C	54/185

PAGE 647 TO 650 NOT ISSUED

PAGE 44 OF 52 NOT ISSUED

SHACKLETON Mk. 2

MAIN PLANES
INNER MAIN PLANE

Ref. No.	Part No.	Description				No. off	Matl. Spec.	Cl. of St.	Plate and Illust'n No.
		1	2	3	4			M.R.	
COMPLEMENTARY ITEMS									
ATTACHMENT FITTINGS, FRONT SPAR JOINT, OUTER TO INNER MAIN-PLANE, PORT AND STARBOARD (1&2F5126)									
1/61									
Consisting of :—									
28D/1011030	A25/2E	Bolt, hex.hd, 1/4" BSF x .7" long, for joint plates				16	MS	C	
14013	6F5062	Nut, for joint pin				4	DTD480 or S11	C	
28M/10290	AGS2001/E/1	Nut, stiff, 1/4" BSF, for joint bolts				16	—	C	
13816	6F5126	Pin, joint (Pre-Mod. 599)				4	DTD480 or S11	C	
5565	14F5126	Pin, joint (Mod. 599)				4	S99	C	
28P/5046	AGS784/22	Pin, split, 1/8" dia. x 2" long				4	Nickel Alloy	C	
26EA/31077	3F5126	Shackle (Pre-Mod. 599)				4	S65	C	
5586	15F5126	Shackle (Mod. 599)				4	S99	C	
13817	7F5126	Washer, joint pin under head				4	L1	C	
13464	4F5126	Washer, joint pin at thread				4	S1	C	
13199	20.O.2277	Washer				2	S1	C	
28W/3072	AGS160/D	Washer, for joint plate, 1/4" dia.				16	—	C	
ATTACHMENT FITTINGS, REAR SPAR JOINT, OUTER TO INNER MAINPLANE PORT AND STARBOARD (10/9F5130)									
1/62									
Consisting of :—									
28D/1011030	A25/2E	Bolt, hex.hd, 1/4" BSF for joint plate				11	MS	C	
14013	6F5062	Nut, for joint pin				4	DTD480 or S11	C	
28M/10290	AGS2001/E/1	Nut, stiff, 1/4" BSF, for joint plate bolts				11	—	C	
26EA/33028	4F5130	Pin, joint (Pre Mod. 599)				4	DTD480	C	
5566	11F5230	Pin, joint (Mod. 599)				4	S99	C	
28P/5046	AGS784/22	Pin, split, 1/8" dia. x 2" long				4	Nickel Alloy	C	
26EA/33027	3F5130	Shackle (Pre Mod. 599)				4	S65	C	
5567	8F5130	Shackle (Mod. 599)				4	S99	C	
13357	5F5062	Washer, joint pin at thread				4	S1	C	
13356	24F5062	Washer, joint pin under head				4	L1	C	
28W/3072	AGS160/D	Washer, 1/4" dia. for joint pin				11	—	C	
13199	20.O.2277	Washer, 1 1/2" dia. joint pin at shackle				4	S1	C	
ATTACHMENT FITTINGS, JOINT COVER STRIPS, INNER TO OUTER MAINPLANE, PORT AND STARBOARD (C2350)									
Consisting of :—									
28D/1007982	AS1248/1C	Bolt, mush.hd, 2 BA x .5" long, for top joint cover strips				230	—	C	
28D/8306	AS1242/1C	Bolt, csk.hd, 2 BA x .5" long for bottom joint cover strips				180	—	C	
STRIP, JOINT COVER, INNER TO OUTER MAINPLANE, PORT (22F5499)									
Consisting of :—									
2647	3F5499	Strip, top				1	L72	C	1/63
2648	23F5499	Strip, bottom				1	L72	C	1/64
	7F5499	STRIP, TRAILING EDGE, GROUP				1	—		1/65

MAIN PLANES
INNER MAIN PLANE

Ref. No.	Part No.	Description				No. off	Matl. Spec.	Cl. of St.	Plate and Illust'n No.
		1	2	3	4			M.R.	
COMPLEMENTARY ITEMS									
STRIP, JOINT COVER, INNER TO OUTER MAINPLANE, STARBOARD, (24F5499)									
Consisting of:—									
2649	4F5499	Strip, top	1	L72	C	1/67
2664	25F5499	Strip, bottom	1	L72	C	1/68
	8F5499	STRIP, TRAILING EDGE, GROUP				1	—		1/69
ATTACHMENT FITTINGS, OUTER TRAILING EDGE TO INNER MAIN-PLANE (F6171)									
Consisting of:—									
28M/10291	AGS2001/G/1	Nut, stiff, $\frac{5}{16}$ "	280	—	C	
28M/10292	AGS2001/J/1	Nut, stiff, $\frac{5}{16}$ "	92	—	C	
28W/12324	SP15/G	Washer, $\frac{5}{16}$ "	280	—	C	
13015	2SS3110	Washer, $\frac{5}{16}$ "	52	—	C	
ATTACHMENT FITTINGS, INNER MAINPLANE TO CENTRE SECTION, FUSELAGE AND PLANE									
(See Complementary Items—"Fuselage—Centre Portion")									
	F6275	Plate, nose joint between ribs 18 and 19 ...				1	—		1/66
SUMMARY OF STOCK ITEMS USED ON INNER MAINPLANE ASSEMBLY									
28D/12534	A25Y/9C	Bolt, hex.hd, 2 BA x 1.35" long ...				4	—	C	
28D/9419397	A25Y/12C	Bolt, hex.hd, 2 BA x 1.65" long ...				2	—	C	
28D/12896	A25Y/25L	Bolt, hex.hd, $\frac{7}{16}$" x 3.2" long ...				2	—	C	
28D/12531	A25/3C	Bolt, hex.hd, 2 BA x .75" long ...				20	—	C	
28V/5109	AGS838/5	Bush,				4	—	C	
28E/8184	AGS605/2	Clip, type "J" ...				3	—	C	
28V/5104	AGS838/1	Connection ...				1	—	C	
28M/10286	AGS2001/A/1	Nut, hex.hd, 6 BA ...				13	—	C	
28M/10287	AGS2001/B/1	Nut, hex.hd, 4 BA ...				14	—	C	
28M/10288	AGS2001/C/1	Nut, hex.hd, 2 BA ...				54	—	C	
28M/10291	AGS2001/G/1	Nut, hex.hd, $\frac{5}{16}$" BSF ...				25	—	C	
28M/10292	AGS2001/J/1	Nut, hex.hd, $\frac{3}{8}$" BSF ...				9	—	C	
28M/10293	AGS2001/L/1	Nut, hex.hd, $\frac{7}{16}$" BSF ...				16	—	C	
28M/11957	AGS2007/C/1	Nut, double anchor, 2 BA ...				32	—	C	
28M/9434251	AGS2008/B/1	Nut, double anchor, 4 BA ...				10	—	C	
28W/8516	AS470/C	Washer, 2 BA ...				8	—	C	
28W/3070	AGS160/B	Washer, 4 BA ...				14	—	C	
28W/3071	AGS160/C	Washer, 2 BA ...				24	—	C	
28W/9418921	SP13/E	Washer, $\frac{1}{4}$" BSF ...				8	—	C	

1948

1949

1950



SHACKLETON Mk. 2

MAIN PLANES
OUTER MAIN PLANE

Ref. No.	Part No.	Description				No. off	Matl. Spec.	Cl. of St.	Plate and Illust'n No.
		1	2	3	4			M.R.	
4006	1F7865	MAINPLANE, ASSEMBLY, OUTER, PORT				1	—	A	55/1
4007	2F7865	MAINPLANE, ASSEMBLY, OUTER, STARBOARD				1	—	A	55/2
(Complementary parts, e.g., Inter-component attachments listed at the end of this assembly will not be supplied with the assembly spare and must be demanded separately when required)									
Spares for :—									
530	MESSIER 7M/4	Adaptor , for de-icing pipes (See De-icing Servies)				8	—	C	66/108
AERIAL, REBECCA, AND CABLES (2&4T2184) (Aerial masts are not supplied with outer main plane) (See Radio & Radar)									
ARM, AILERON, HINGE, AT RIB 22, GROUP (1F5429)									
Spares for :—									
13479	3F5314	Arm , aileron hinge				1	—	C	55/3
13538	2SS3150	Bolt , instrument hd, $\frac{1}{4}$ " BSF x 1" long ...				1	S2	C	55/4
13023	3SS3150	Bolt , instrument hd, $\frac{1}{4}$ " BSF x $1\frac{1}{8}$ " long ...				1	S2	C	55/5
13539	5SS3150	Bolt , instrument hd, $\frac{1}{4}$ " BSF x $1\frac{3}{8}$ " long ...				1	S2	C	55/6
13540	6SS3150	Bolt , instrument hd, $\frac{1}{4}$ " BSF x $1\frac{1}{2}$ " long ...				1	S2	C	55/7
13024	8SS3150	Bolt , instrument hd, $\frac{1}{4}$ " BSF x $1\frac{3}{4}$ " long ...				1	S2	C	55/8
13500	4F5429	Bolt , hex.hd, 2 BA attachment of control rod to arm				1	—	C	55/9
13211	3G1384	Bush , control rod attachment				2	—	C	55/10
28M/767	A16Y/CS	Nut , slotted, 2 BA				1	—	C	
	5F5429	Strip , packing, $11\frac{1}{2}$ " x 1" x $\frac{1}{16}$ "				1	Lamimum		55/11
5536	9F5485	Cover , for CA7 bearing (Mod. 587)				2	S84 or S3		
ARM, AILERON HINGE, AT RIB 33, GROUP (1F5430)									
Spares for :—									
13478	3F5325	Arm , aileron hinge				1	—	C	55/12
13541	1SS3150	Bolt , instrument hd, $\frac{1}{4}$ " BSF x $\frac{7}{8}$ " long ...				1	S2	C	55/13
13023	3SS3150	Bolt , instrument hd, $\frac{1}{4}$ " BSF x 1" long ...				1	S2	C	55/5
13529	5SS3150	Bolt , instrument hd, $\frac{1}{4}$ " BSF x $1\frac{1}{8}$ " long ...				1	S2	C	55/6
13540	6SS3150	Bolt , instrument hd, $\frac{1}{4}$ " BSF x $1\frac{1}{2}$ " long ...				1	S2	C	55/7
13542	7SS3150	Bolt , instrument hd, $\frac{1}{4}$ " BSF x $1\frac{3}{8}$ " long ...				1	S2	C	55/14
	4F5430	Strip , packing, 11" x 1" x $\frac{1}{16}$ "				1	Lamimum		55/15

MAIN PLANES
OUTER MAIN PLANE

Ref. No.	Part No.	Description				No. off	Matl. Spec.	Cl. of St.	Plate and Illust'n No.
		1	2	3	4			M.R.	
		CONDUIT, FOR ELECTRICAL SERVICES GROUP (1&2F6472)							
		Consisting of:—							
	8F5513	Bracket, rib 39, port	1	—		55/23	
	9F5513	Bracket, rib 39, starboard	1	—		55/24	
13637	3SS3266	Clip, attachment of conduit	1.P	—	C	55/25	
					10.S				
13009	6SS2868	Clip, attachment of conduit rib 7-8	2	—	C	55/26	
13726	3SS3512	Clip, attachment of conduit	10.P	—	C	55/27	
					1.S				
13093	8SS3264	Clip, attachment of conduit at rib 39	2	—	C	55/28	
	5F5884	Tube, conduit, between ribs 38-39	1	T9		55/29	
	7F5884	Tube, jointing, conduit	1	T9		55/30	
		DOOR, ACCESS TO REBECCA AERIAL CONNECTION, BETWEEN RIBS 37-38, GROUP (1&2F6512)							
		Consisting of:—							
28D/9583	AS1852/1/2C	Bolt, mush.hd, 2 BA x 0.45" long...	4	—	C		
	4F6512	Door, access	1	—		56/31	
1911	3F6512	Frame, door	1	—	C	56/32	

SHACKLETON Mk. 2

MAIN PLANE
OUTER MAIN PLANE

Ref. No.	Part No.	Description				No. off	Matl. Spec.	Cl. of St.	Plate and Illust'n No.
		1	2	3	4			M.R.	
		ELECTRICAL INSTALLATION IN OUTER MAIN PLANE, PORT AND STARBOARD (2&4V5821) (See Electrical Installation)							
517	1F5516	ENDSWEEP, NOSE TIP OF WING, PORT, GROUP				1	—	C	56/33
		Consisting of:—							
	7F5516	Endsweep, (Alum.Alloy 20g)				1	L72		
	9F5516	Piece, packing				1	Hardwood		
	11F5516	Piece, packing				1	Hardwood		
28S/2493	AGS251/39	Woodscrew, csk.hd, No. 6 x 3/4" long ...				4	—	C	
519	3F5516	ENDSWEEP, CENTRE TIP OF WING, PORT, GROUP				1	—	C	56/34
518	2F5516	ENDSWEEP, NOSE TIP OF WING, STARBOARD, GROUP				1	—	C	56/35
		Consisting of:—							
	8F5516	Endsweep (Alum. Alloy 20g)				1	L72		
	10F5516	Piece, packing				1	Hardwood		
	12F5516	Piece, packing				1	Hardwood		
28S/2493	AGS251/39	Woodscrew, csk.hd, No. 6 x 3/4" long ...				4	—	C	
520	4F5516	Endsweep, centre tip of wing, starboard ...				1	L72		56/36
521	2F6315	Insert, metal, de-icing, bottom ribs 19-25 ...				1	—	C	66/119
522	3F6315	Insert, metal, de-icing, top ribs 19-25 ...				1	—	C	66/120
523	3F5811	Insert, metal, de-icing, bottom ribs 26-30 ...				1	—	C	66/121
524	5F5811	Insert, metal, de-icing, top ribs, 26-30 ...				1	—	C	66/122
525	4F5783	Insert, metal, de-icing, ribs 31-36 (See Services De-icing)				1	—	C	66/123
		LAMP, NAVIGATION, PORT AND STARBOARD (7&8F5515)							
		Consisting of:—							
28D/8485	AS1885/2C	Bolt, mush.hd, 2 BA x .6" long				7	—	C	
28D/8307	AS1242/2C	Bolt, csk.hd, 2 BA x .6" long				2	—	C	
1907	1F7425	MOULDING AND ACCESS DOOR FOR NAVIGATION LIGHT, PORT, GROUP				1	—	C	56/37
1908	2F7425	MOULDING AND ACCESS DOOR FOR NAVIGATION LIGHT, STARBOARD, GROUP						C	56/38
		Spares for:—							
	3F7425	Door, access to lamp, port				1	DTD339		
	9F7425	Door, access to lamp, starboard				1	DTD339		

MAIN PLANES
OUTER MAIN PLANE

Ref. No.	Part No.	Description				No. off	Matl. Spec.	Cl. of St.	Plate and Illust'n No.
		1	2	3	4			M.R.	
		MOUNTING, FLUX DETECTOR UNIT, MARK 4B (1S1695)							
		Consisting of:—							
28D/10570	AS1247/1C	Bolt, rd.hd, 2 BA	3	—	C	
	2S1695	BRACKET, GROUP	1	—		56/39
6B/1993	—	Detector, unit	1	—	A	
	4F6501	RING, ADAPTOR, GROUP	1	—		56/40
28S/2066	AGS246/12	Screw, cheese hd, 2 BA	3	—	C	
		MOUNTING, LAMP, TAXYING, PORT AND STARBOARD (1&2F7880)							
		Consisting of:—							
	3F7880	Bracket, port	1	L72		56/41
	4F7880	Bracket, starboard	1	L72		56/42
	5F7880	Bracket, port	1	L72		56/43
	6F7880	Bracket, starboard	1	L72		56/44
	7F7880	Bracket, attachment	1	—		56/46
5CX/1518	—	Rig, mounting	1	—	B	56/45
28Q/10652	AS2228/405	Rivet, mush.hd, 1/8" dia. x 5/16" long	23	DTD327	C	
28Q/10408	AS2228/406	Rivet, mush.hd, 1/8" dia. x 3/8" long	8	DTD327	C	
28Q/6639	AS2227/405	Rivet, mush.hd, 1/8" dia. x 5/16" long	11	DTD327	C	
528	MESSIER 5M.4	Nut, coupling, de-icing pipes	14	—	C	66/142
529	MESSIER 4M.4	Olive, de-icing pipes	14	—	C	66/143
	32F7181	Plate, joint for nose plates, between ribs No. 25-26, port and starboard				1	L72		
1211	1F7186	PLATE, NOSE, RIBS 19-25, PORT, GROUP				1	—	C	55/47
		The following items supplied loose with this Group:—							
7011	5F7186	Block, end	2	L40	C	
28M/12153	AGS2007/B/1	Nut, anchor, 4 BA	6	—	C	
28M/8904	AGS2012/B/11	Nut, anchor, 4 BA	10	—	C	
28Q/10432	AS2230/304	Rivet, csk.hd, 3/32" dia. x 1/4" long	32	—	C	
28S/6112	AGS968/26	Screw, 4 BA	6	—	C	
6997	3F4878	Washer, sealing	10	Langite	C	

SHACKLETON Mk. 2

MAIN PLANES
OUTER MAIN PLANE

Ref. No.	Part No.	Description				No. off	Matl. Spec.	Cl. of St.	Plate and Illust'n No.
		1	2	3	4			M.R.	
1212	2F7186	PLATE, NOSE, RIBS 19-25, STARBOARD, GROUP				1	—	C	55/48
		The following items supplied loose with this Group :—							
7011	5F7186	Block, end				2	L40	C	
28M/12153	AGS2007/B/1	Nut, anchor, 4 BA				6	—	C	
28M/8904	AGS2012/B/11	Nut, anchor, 4 BA				10	—	C	
28Q/10432	AS2230/304	Rivet, csk.hd, $\frac{3}{32}$ " dia. x $\frac{1}{4}$ " long				32	—	C	
28S/6112	AGS968/26	Screw, 4 BA				6	—	C	
6997	3F4878	Washer, sealing				10	Langite	C	
1213	1F7187	PLATE, NOSE, RIBS 26-30, PORT, GROUP				1	—		55/49
		The following items supplied loose with this Group :—							
7012	5F7187	Block, end				1	L40		
	6F7187	Block, end				1	L40	C	
	18F7187	Liner				2	L72		
28M/12153	AGS2007/B/1	Nut, anchor, 4 BA				4	—	C	
28M/8904	AGS2012/B/11	Nut, anchor, 4 BA				8	—	C	
28Q/10432	AS2230/304	Rivet, csk.hd, $\frac{3}{32}$ " dia. x $\frac{1}{4}$ " long				20	—	C	
28Q/10694	AS2230/305	Rivet, csk.hd, $\frac{3}{32}$ " dia. x $\frac{5}{16}$ " long				4	—	C	
6997	3F4878	Washer, sealing				8	Langite	C	
1214	2F7187	PLATE, NOSE, RIBS 26-30, STARBOARD, GROUP				1	—	C	55/50
		The following items supplied loose with this Group :—							
7012	5F7187	Block, end				1	L40		
	6F7187	Block, end				1	L40	C	
	18F7187	Liner				2	L72		
28M/12153	AGS2007/B/1	Nut, anchor, 4 BA				4	—	C	
28M/8904	AGS2012/B/11	Nut, anchor, 4 BA				8	—	C	
28Q/10432	AS2230/304	Rivet, csk.hd, $\frac{3}{32}$ " dia. x $\frac{1}{4}$ " long				20	—	C	
28Q/10694	AS2230/305	Rivet, csk.hd, $\frac{3}{32}$ " dia. x $\frac{5}{16}$ " long				4	—	C	
6997	3F4878	Washer, sealing				8	Langite	C	

MAIN PLANES
OUTER MAIN PLANE

Ref. No.	Part No.	Description				No. off	Matl. Spec.	Cl. of St.	Plate and Illust'n No.
		1	2	3	4			M.R.	
	1F7877	PLATE, NOSE RIBS 30-37, PORT, GROUP				1	—		55/51
		The following items supplied loose with this Group :—							
	9F7877	Block, end	1	L40		
	6F7877	Block, end	1	DTD31		
28M/8904	AGS2012/B1	Nut, anchor, 4 BA	7	—	C	
28Q/10432	AS2230/304	Rivet, csk.hd, $\frac{3}{32}$ " dia. x $\frac{1}{4}$ " long	4	—	C	
28Q/10682	AS2230/412	Rivet, csk.hd, $\frac{3}{16}$ " dia. x $\frac{3}{4}$ " long	3	—	C	
6997	3F4878	Washer, sealing	5	Langite	C	
	2F7877	PLATE, NOSE RIBS 30-37 STARBOARD, GROUP							55/52
		The following items supplied loose with this Group :—							
	6F7188	Block, end	1	L40		
	6F7877	Block, end	1	DTD31		
28M/8904	AGS2012/B1	Nut, anchor, 4 BA	7	—	C	
28Q/10432	AS2230/304	Rivet, csk.hd, $\frac{3}{32}$ " dia. x $\frac{1}{4}$ " long	4	—	C	
28Q/10682	AS2230/412	Rivet, csk.hd, $\frac{3}{16}$ " dia. x $\frac{3}{4}$ " long	3	—	C	
6997	3F4878	Washer, sealing	5	Langite	C	
1461	—	RIB, No. 19, NOSE PORTION, PORT GROUP (1F7235)				1	—	C	55/53
		Consisting of :—							
	6F5270	Angle, top	1	L72		
	10F5270	Angle, bottom	1	L72		
28M/9999	AGS2012/C/11	Nut, floating anchor	1	—	C	
28Q/10566	AS2230/303	Rivet, csk.hd, 120°, $\frac{3}{32}$ " dia. x $\frac{3}{16}$ " long	28	—	C	
28Q/6638	AS2227/404	Rivet, snap hd, $\frac{1}{8}$ " dia. x $\frac{1}{4}$ " long	39	—	C	
28M/12336	AGS2015/C/11/ ·8 pitch/11	Strip, nut, aerotight, ·8" pitch, 12 nuts	1	—	C	
28M/12336	AGS2015/C/11/ ·8 pitch/10	Strip, nut, aerotight, ·8" pitch, 11 nuts	1	—	C	
	3F7235	Web, nose rib...	1	L72		

SHACKLETON Mk 2

MAIN PLANES
OUTER MAIN PLANE

Ref. No.	Part No.	Description				No. off	Matl. Spec.	Cl. of St.	Plate and Illust'n No.
		1	2	3	4			M.R.	
1462	—	RIB, No. 19, NOSE PORTION, STARBOARD, GROUP (2F7235)				1	—	C	55/54
		Consisting of:—							
	7F5270	Angle, top	1	DTD610		
	11F5270	Angle, bottom	1	DTD610		
28M/9999	AGS2012/C/11	Nut, floating anchor	1	—	C	
28Q/10566	AS2230/303	Rivet, csk.hd, 120°, 3/32" dia. x 3/16" long	28	—	C	
28Q/6638	AS2227/404	Rivet, snap hd, 1/8" dia. x 1/4" long	39	—	C	
28M/12336	AGS2015/C/11/ -8 pitch/11	Strip, nut, Aerotight, -8" pitch, 11 nuts...	1	—	C	
28M/12336	AGS2015/C/11/ -8 pitch/10 4F7235	Strip, nut, Aerotight, -8" pitch, 12 nuts...	1	—	C	
		Web, nose rib...	1	DTD610		
		RIB, No. 20, NOSE PORTION, PORT, (1F6673)				1	—		55/55
		Consisting of:—							
13145	2SS3073	Bracket, stringer attachment	1	DTD610	C	
13144	2SS3072	Bracket, stringer attachment	1	DTD610	C	
28Q/6638	AS2227/404 3F6673	Rivet, snap hd, 1/8" dia. x 1/4" long	8	—	C	
		Web, nose rib...	1	DTD610		
		RIB, No. 20, NOSE PORTION, STARBOARD (2F6673)				1	—		55/56
		Consisting of:—							
13144	2SS3072	Bracket, stringer attachment	1	DTD610	C	
13145	2SS3073	Bracket, stringer attachment	1	DTD610	C	
28Q/6638	AS2227/404 4F6673	Rivet, snap hd, 1/8" dia. x 1/4" long	8	—	C	
		Web, nose rib...	1	DTD610		
		RIB, No. 21, NOSE PORTION, PORT, (1F6674)				1	—		55/57
		Consisting of:—							
13144	2SS3072	Bracket, stringer attachment	1	DTD610	C	
13145	2SS3073	Bracket, stringer attachment	1	DTD610	C	
Q28/6638	AS2227/404 3F6674	Rivet, snap hd, 1/8" dia. x 1/4" long	4	—	C	
		Web, nose rib...	1	DTD610		
		RIB, No. 21, NOSE PORTION, STARBOARD (2F6674)				1	—		55/58
		Consisting of:—							
13144	2SS3072	Bracket, stringer attachment	1	DTD610	C	
13145	2SS3073	Bracket, stringer attachment	1	DTD610	C	
28Q/6638	AS2227/404 4F6674	Rivet, snap hd, 1/8" dia. x 1/4" long	4	—	C	
		Web, nose rib...	1	DTD610		
		RIB, No. 22, NOSE PORTION, PORT, (1F6675)				1	—		55/59
		Consisting of:—							
13144	2SS3072	Bracket, stringer attachment	1	DTD610	C	
13145	2SS3073	Bracket, stringer attachment	1	DTD610	C	
28Q/6638	AS2227/404 3F6675	Rivet, snap hd, 1/8" dia. x 1/4" long	4	—	C	
		Web, nose rib...	1	DTD610		

MAIN PLANES
OUTER MAIN PLANE

Ref. No.	Part No.	Description				No. off	Matl. Spec.	Cl. of St.	Plate and Illust'n No.
		1	2	3	4			M.R.	
		RIB, No. 22, NOSE PORTION, STARBOARD (2F6675)				1	—		55/60
		Consisting of:—							
13144	2SS3072	Bracket, stringer attachment	1	DTD610	C		
13145	2SS3073	Bracket, stringer attachment	1	DTD610	C		
28Q/6638	AS2227/404	Rivet, snap hd, 1/8" dia. x 1/4" long	4	—	C		
	4F6675	Web, nose rib...	1	DTD610			
		RIB, No. 23, NOSE PORTION, PORT, (1F6676)				1	—		55/61
		Consisting of:—							
13144	2SS3072	Bracket, stringer attachment	1	DTD610	C		
13145	2SS3073	Bracket, stringer attachment	1	DTD610	C		
28Q/6638	AS2227/404	Rivet, snap hd, 1/8" dia. x 1/4" long	4	—			
	3F6676	Web, nose rib...	1	DTD610			
		RIB, No. 23, NOSE PORTION, STARBOARD (2F6676)				1	—		55/62
		Consisting of:—							
13144	2SS3072	Bracket, stringer attachment	1	DTD610	C		
13145	2SS3073	Bracket, stringer attachment	1	DTD610	C		
28Q/6638	AS2227/404	Rivet, snap hd, 1/8" dia. x 1/4" long	4	—	C		
	4F6676	Web, nose rib...	1	DTD610			
		RIB, No. 24, NOSE PORTION, PORT, (1F6677)				1	—		55/63
		Consisting of:—							
13144	2SS3072	Bracket, stringer attachment	1	DTD610	C		
13145	2SS3073	Bracket, stringer attachment	1	DTD610	C		
28Q/6638	AS2227/404	Rivet, snap hd, 1/8" dia. x 1/4" long	7	—	C		
	3F6677	Web, nose rib...	1	DTD610			
		RIB, No. 24, NOSE PORTION, STARBOARD (2F6677)				1	—		55/64
		Consisting of:—							
13144	2SS3072	Bracket, stringer attachment	1	DTD610	C		
13145	2SS3073	Bracket, stringer attachment	1	DTD610	C		
28Q/6638	AS2227/404	Rivet, snap hd, 1/8" dia. x 1/4" long	7	—	C		
	4F6677	Web, nose rib...	1	DTD610			
		RIB, No. 25, NOSE PORTION, PORT, (1F6678)				1	—		55/65
		Consisting of:—							
13144	2SS3072	Bracket, stringer attachment	1	DTD610	C		
13145	2SS3073	Bracket, stringer attachment	1	DTD610	C		
28Q/6638	AS2227/404	Rivet, snap hd, 1/8" dia. x 1/4" long	4	—	C		
	3F6678	Web, nose rib...	1	DTD610			
		RIB, No. 25, NOSE PORTION, STARBOARD (2F6678)				1	—		55/66
		Consisting of:—							
13144	2SS3072	Bracket, stringer attachment	1	DTD610	C		
13145	2SS3073	Bracket, stringer attachment	1	DTD610	C		
28Q/6638	AS2227/404	Rivet, snap hd, 1/8" dia. x 1/4" long	4	—	C		
	4F6678	Web, nose rib...	1	DTD610			

SHACKLETON Mk. 2

MAIN PLANES
OUTER MAIN PLANE

Ref. No.	Part No.	Description				No. off	Matl. Spec.	Cl. of St.	Plate and Illust'n No.
		1	2	3	4			M.R.	
		RIB, No. 26, NOSE PORTION, PORT (1F6679)				1	—		55/67
		Consisting of:—							
13144	2SS3072	Bracket, stringer attachment	1	DTD610	C		
13145	2SS3073	Bracket, stringer attachment	1	DTD610	C		
28Q/6638	AS2227/404	Rivet, snap hd, 1/8" dia. x 1/4" long	4	—	C		
	3F6679	Web, nose rib...	1	DTD610			
		RIB, No. 26, NOSE PORTION, STARBOARD (2F6679)				1	—		55/68
		Consisting of:—							
13144	2SS3072	Bracket, stringer attachment	1	DTD610	C		
13145	2SS3073	Bracket, stringer attachment	1	DTD610	C		
28Q/6638	AS2227/404	Rivet, snap hd, 1/8" dia. x 1/4" long	4	—	C		
	4F6679	Web, nose rib...	1	DTD610			
		RIB, No. 27, NOSE PORTION, PORT, (1F6680)				1	—		55/69
		Consisting of:—							
13144	2SS3072	Bracket, stringer attachment	1	DTD610	C		
13145	2SS3073	Bracket, stringer attachment	1	DTD610	C		
28Q/6638	AS2227/404	Rivet, snap hd, 1/8" dia. x 1/4" long	4	—	C		
	3F6680	Web, nose rib...	1	DTD610			
		RIB, No. 27, NOSE PORTION, STARBOARD, (2F6680)				1	—		55/70
		Consisting of:—							
13144	2SS3072	Bracket, stringer attachment	1	DTD610	C		
13145	2SS3073	Bracket, stringer attachment	1	DTD610	C		
28Q/6638	AS2227/404	Rivet, snap hd, 1/8" dia. x 1/4" long	4	—	C		
	4F6680	Web, nose rib...	1	DTD610			
		RIB, No. 28, NOSE PORTION, PORT (1F6681)				1	—		55/71
		Consisting of:—							
13144	2SS3072	Bracket, stringer attachment	1	DTD610	C		
13145	2SS3073	Bracket, stringer attachment	1	DTD610	C		
28Q/6638	AS2227/404	Rivet, snap hd, 1/8" dia. x 1/4" long	4	—	C		
	3F6681	Web, nose rib...	1	DTD610			
		RIB, No. 28, NOSE PORTION, STARBOARD (2F6681)				1	—		55/72
		Consisting of:—							
13144	2SS3072	Bracket, stringer attachment	1	DTD610	C		
13145	2SS3073	Bracket, stringer attachment	1	DTD610	C		
28Q/6638	AS2227/404	Rivet, snap hd, 1/8" dia. x 1/4" long	4	—	C		
	4F6681	Web, nose rib...	1	DTD610			
		RIB, No. 29, NOSE PORTION, PORT (1F6682)				1	—		55/73
		Consisting of:—							
13144	2SS3072	Bracket, stringer attachment	1	DTD610	C		
13145	2SS3073	Bracket, stringer attachment	1	DTD610	C		
28Q/6638	AS2227/404	Rivet, snap hd, 1/8" dia. x 1/4" long	4	—	C		
	3F6682	Web, nose rib...	1	DTD610			

MAIN PLANES
OUTER MAIN PLANE

Ref. No.	Part No.	Description				No. off	Matl. Spec.	Cl. of St.	Plate and Illust'n No.
		1	2	3	4			M.R.	
		RIB, No. 29, NOSE PORTION, STARBOARD (2F6682)				1	—		55/74
		Consisting of:—							
13144	2SS3072	Bracket, stringer attachment	1	DTD610	C		
13145	2SS3073	Bracket, stringer attachment	1	DTD610	C		
28Q/6638	AS2227/404	Rivet, snap hd, 1/8" dia. x 1/4" long	4	—	C		
	4F6682	Web, nose rib...	1	DTD610			
	1F7883	RIB, No. 30, NOSE PORTION, PORT,				1	—		55/75
		Consisting of:—							
	5F7883	Bracket, attachment	1	DTD610			
	7F7883	Bracket, attachment	1	DTD610			
13144	2SS3072	Bracket...	1	—			
28Q/6638	AS2227/404	Rivet, snap hd, 1/8" dia. x 1/4" long	7	—			
	3F7883	Web, nose rib...	1	DTD610			
	2F7883	RIB, No. 30, NOSE PORTION, STARBOARD							55/76
		Consisting of:—							
	5F7883	Bracket, attachment	1	DTD610			
	8F7883	Bracket, attachment	1	DTD610			
13145	2SS3073	Bracket...	1	DTD610	C		
28Q/6638	AS2227/404	Rivet, snap hd, 1/8" dia. x 1/4" long	7	—	C		
	4F7784	Web, nose rib...	1	DTD610			
	1F7884	RIB, No. 31, NOSE PORTION, PORT							55/77
		Consisting of:—							
13144	2SS3072	Bracket, attachment	1	DTD610	C		
13218	7SS3072	Bracket, attachment	1	DTD610	C		
28Q/6638	AS2227/404	Rivet, snap hd, 1/8" dia. x 1/4" long	4	—	C		
	3F7884	Web, nose rib...	1	DTD610			
	2F7884	RIB, No. 31, NOSE PORTION, STARBOARD,				1	—		55/78
		Consisting of:—							
13144	2SS3072	Bracket, attachment	1	DTD610	C		
13219	7SS3073	Bracket, attachment	1	DTD610	C		
28Q/6638	AS2227/404	Rivets, snap hd, 1/8" dia. x 1/4" long	4	—	C		
	4F7884	Web, nose	1	DTD610			
		RIB, No. 32, NOSE PORTION, PORT (1F6685)				1	—		55/79
		Consisting of:—							
13144	2SS3072	Bracket, stringer attachment	1	DTD610	C		
13218	7SS3072	Bracket, stringer attachment	1	DTD610	C		
28Q/6638	AS2227/404	Rivet, snap hd, 1/8" dia. x 1/4" long	4	—	C		
	3F6685	Web, nose rib...	1	DTD610			

SHACKLETON Mk. 2

MAIN PLANES
OUTER MAIN PLANE

Ref. No.	Part No.	Description				No. off	Matl. Spec.	Cl. of St.	Plate and Illust'n No.
		1	2	3	4			M.R.	
		RIB, No. 32, NOSE PORTION, STARBOARD (2F6685)							55/80
		Consisting of:—							
13145	2SS3073	Bracket, stringer attachment	1	DTD610	C		
13219	7SS3073	Bracket, stringer attachment	1	DTD610	C		
28Q/6638	AS2227/404	Rivet, snap hd, 1/8" dia. x 1/4" long	4	—	C		
	4F6685	Web, nose rib...	1	DTD610			
		RIB, No. 33, NOSE PORTION, PORT (1F6686)				1	—		55/81
		Consisting of:—							
13144	2SS3072	Bracket, stringer attachment	1	DTD610	C		
13218	7SS3072	Bracket, stringer attachment	1	DTD610	C		
38Q/6638	AS2227/404	Rivet, snap hd, 1/8" dia. x 1/4" long	4	—	C		
	3F6686	Web, nose rib...	1	DTD610			
		RIB, No. 33, NOSE PORTION, STARBOARD (2F6686)				1	—		55/82
		Consisting of:—							
13145	2SS3073	Bracket, stringer attachment	1	DTD610	C		
13219	7SS3073	Bracket, stringer attachment	1	DTD610	C		
28Q/6638	AS2227/404	Rivet, snap hd, 1/8" dia. x 1/4" long	4	—	C		
	4F6686	Web, nose rib...	1	DTD610			
		RIB, No. 34, NOSE PORTION, PORT, (1F6687)				1	—		55/83
		Consisting of:—							
13144	2SS3072	Bracket, stringer attachment	1	DTD610	C		
13218	7SS3072	Bracket, stringer attachment	1	DTD610	C		
28Q/6638	AS2227/404	Rivet, snap hd, 1/8" dia. x 1/4" long	4	—	C		
	3F6687	Web, nose rib...	1	DTD610			
		RIB, No. 34, NOSE PORTION, STARBOARD (2F6687)							55/84
		Consisting of:—							
13145	2SS3073	Bracket, stringer attachment	1	DTD610	C		
13219	7SS3073	Bracket, stringer attachment	1	DTD610	C		
28Q/6638	AS2227/404	Rivet, snap hd, 1/8" dia. x 1" long	4	—	C		
	4F6687	Web, nose rib...	1	DTD610			
		RIB, No. 35, NOSE PORTION, PORT, (1F6688)				1	—		55/85
		Consisting of:—							
13144	2SS3072	Bracket, stringer attachment	1	DTD610	C		
13218	7SS3072	Bracket, stringer attachment	1	DTD610	C		
28Q/6638	AS2227/404	Rivet, snap hd, 1/8" dia. x 1/4" long	4	—	C		
	3F6688	Web, nose rib...	1	DTD610			

MAIN PLANES
OUTER MAIN PLANE

Ref. No.	Part No.	Description				No. off	Matl. Spec.	Cl. of St.	Plate and Illust'n No.
		1	2	3	4			M.R.	
		RIB, No. 35, NOSE PORTION, STARBOARD (2F6688)							55/86
		Consisting of:—							
13145	2SS3073	Bracket, stringer attachment	1	DTD610	C		
13219	7SS3073	Bracket, stringer attachment	1	DTD610	C		
28Q/6638	AS2227/404	Rivet, snap hd, $\frac{1}{8}$ " dia. x $\frac{1}{4}$ " long	4	—	C		
	4F6688	Web, nose rib...	1	DTD610			
		RIB, No. 36, NOSE PORTION, PORT (1F6689)				1	—		55/87
		Consisting of:—							
13144	2SS3072	Bracket, stringer attachment	1	DTD610	C		
13218	7SS3072	Bracket, stringer attachment	1	DTD610	C		
28Q/6638	AS2227/404	Rivet, snap $\frac{1}{8}$ " dia. x $\frac{1}{4}$ " long	4	—	C		
	3F6689	Web, nose rib...	1	DTD610			
		RIB, No. 36, NOSE PORTION, STARBOARD (2F6689)				1	—		55/88
		Consisting of:—							
13145	2SS3073	Bracket, stringer attachment	1	DTD610	C		
13219	7SS3073	Bracket, stringer attachment	1	DTD610	C		
28Q/6638	AS2227/404	Rivet, snap hd, $\frac{1}{8}$ " dia. x $\frac{1}{4}$ " long	4	—	C		
	4F6688	Web, nose rib...	1	DTD610			
	1F6690	RIB, No. 37, NOSE PORTION, PORT, GROUP				1	—		55/89
	2F6690	RIB, No. 37, NOSE PORTION, STARBOARD, GROUP				1	—		55/90
13825	1F5289	Rib, No. 38, nose portion, port	1	DTD610	C	55/91	
26EA/31762	2F5289	Rib, No. 38, nose portion, starboard	1	DTD610	C	55/92	
	1F7431	Rib, No. 39, nose portion, port	1	—		55/93	
	2F7431	Rib, No. 39, nose portion, starboard	1	—		55/94	
		SHAFT, AILERON CONTROL, PORT AND STARBOARD (1&2F5485) (See Controls—Flying)							
		SHAFT, AILERON TORQUE, PORT AND STARBOARD (1&2R2473) (See Controls—Flying)							
		SKINNING, TOP, PORT AND STARBOARD (14&15F5171)							
		Spares for:—							
26EA/32187	11F5171	Blister, fairing, at aileron fulcrum	1	—	C	55/95	
	2F5602	Door, access for flux detector	1	—		55/96	
13285	3F4033	Plug, special, slinging attachment point	4	—	C	55/97	
28S/9934	Parker Kalon	Screw, No. 7, 120°, raised csk.hd, "Z" Type, $\frac{5}{16}$ " long			500	—	C		

SHACKLETON Mk 2

MAIN PLANES
OUTER MAIN PLANE

Ref. No.	Part No.	Description				No. off	Matl. Spec.	Cl. of St.	Plate and Illust'n No.
		1	2	3	4			M.R.	
SKINNING, BOTTOM, PORT AND STARBOARD (13&14F5776)									
Spares for :—									
13124	30SS3221	Door, access, to de-icer connections ...				5	—	C	55/98
1912	1F6496	DOOR, ACCESS, TO NAVIGATION LIGHT TERMINALS, PORT, GROUP				1	—	C	55/99
1913	2F6496	DOOR, ACCESS, TO NAVIGATION LIGHT TERMINALS, STARBOARD, GROUP				1	—	C	55/100
Consisting of :—									
5H/1	AS2633	Block, connector, base 2 way ...				1	—	C	55/101
28D/8449	AS1882/1B	Bolt, csk.hd, 4 BA x .45" long ...				2	—	C	55/102
5H/7	AS2601	Cover, block connector, top, 2 way ...				1	—	C	55/103
2351	3F6496	Door ...				1	DTD610	C	55/104
	4V4424	Label, for T.B. Identification port ...				1	—	C	55/105
	54V4424	Label, for T.B. Identification, starboard				1	—	C	55/105
	155Z1196	Label ...				1	—	C	55/106
28M/10327	AGS2002/B/1	Nut, stiff, 4 BA, thin ...				2	—	C	55/107
28Q/10850	AS2228/203	Rivet, mush.hd, 1/16" dia. x 3/16" long ...				4	—	C	55/108
5H/124	—	Socket, 19 amp., single tier ...				2	—	C	55/109
1914	1F6497	DOOR, ACCESS, LANDING LAMP AND JOINT TERMINALS, PORT, GROUP				1	—	C	55/110
1915	2F6497	DOOR, ACCESS, LANDING LAMP AND JOINT TERMINALS, STARBOARD, GROUP				1	—	C	55/111
Consisting of :—									
5H/1	AS2633	Block, connector, base, 2 way ...				1	—	C	55/112
5H/3	AS2635	Block, connector, base, 5 way ...				1	—	C	55/113
28D/8449	AS1882/1B	Bolt, csk.hd, 4 BA x .45" long ...				4	—	C	55/114
5H/7	AS2601	Cover, block connector, top, 2 way ...				1	—	C	55/115
5H/9	AS2603	Cover, block connector, top, 5 way ...				1	—	C	55/116
2352	3F6497	Door ...				1	—	C	55/117
	1V4424	Label, for T.B. Identification, port ...				1	—	C	55/118
	51V4424	Label, for T.B. Identification, starboard				1	—	C	55/119
	2V4424	Label, for T.B. Identification, port ...				1	—	C	55/120
	52V4424	Label, for T.B. Identification, starboard				1	—	C	55/121
	578SS4000	Label ...				1	—	C	55/122
28M/10327	AGS2002/B/1	Nut, stiff, 4 BA, thin ...				4	—	C	55/123
28Q/10850	AS2228/203	Rivet, mush.hd, 1/16" dia. x 3/16" long ...				4	—	C	55/124
5H/124	—	Socket, 19 amp., single tier ...				5	—	C	55/125
5H/125	—	Socket, 19 amp., double tier ...				2	—	C	55/126
	1F8459	DOOR, ACCESS TO TAXYING LAMP TERMINALS PORT, GROUP				1	—	C	55/127
	2F8459	DOOR, ACCESS TO TAXYING LAMP TERMINALS STARBOARD, GROUP				1	—	C	55/128
Consisting of :—									
5H/3	AS2635	Block, connector base 5 way ...				1	—	C	55/129
28D/8300	AS1242/1B	Bolt, csk.hd. 4BA x .45" long ...				2	—	C	55/130
5H/9	AS2603	Cover, block, connector top 5 way ...				1	—	C	55/131
13124	30SS3221	Door, access to taxying lamp ...				1	—	C	55/132
	420SS6001	Label, access to taxying lamp terminals				1	—	C	55/133
	88V4424	Label, taxy lamps ...				1	—	C	55/134
28M/10327	AGS2001/B/1	Nut, stiff 4BA ...				2	—	C	55/135
28Q/10850	AS2228/203	Rivet, mush. hd. 1/16" dia. x 3/16" long ...				4	—	C	55/136
5H/124	—	Socket, single tier ...				2	—	C	55/137
28W/12346	SP10/B	Washer 4BA ...				2	—	C	55/138

PAGE 667 TO 670 NOT ISSUED

1972-1973

MADE BY THE WOLF BRAND



SHACKLETON Mk 2

MAIN PLANES

OUTER MAIN PLANE

Ref. No.	Part No.	Description				No. off	Matl. Spec.	Cl. of St.	Plate and Illust'n No.
		1	2	3	4			M.R.	
COMPLEMENTARY ITEMS									
ATTACHMENT FITTINGS, WING TIP TO OUTER MAINPLANE, PORT AND STARBOARD									
1/71									
Consisting of :—									
28M/10328	AGS2002/C/1					36	—	C	
28W/8516	AS470/C					36	—	C	
ATTACHMENT FITTINGS, OUTBOARD AILERON TO OUTER MAINPLANE AT RIB No. 22, PORT AND STARBOARD (F5429)									
1/72									
Consisting of :—									
13022	5F3806					1	S1	C	
13500	4F5429					1	S1	C	
Bolt, hex.hd, $\frac{5}{8}$ " BSF x $2\frac{1}{8}$ " long aileron hinge									
Bolt, hex.hd, 2 BA x 1.14" long attachment of trimmer control rod to hinge arm									
13027	6F3806					2	L40	C	
5533	3F5427					2	L40	C	
Bush, for $\frac{5}{8}$ " BSF bolt (Pre Mod. 578) ...									
Bush, for $\frac{5}{8}$ " BSF bolt (Mod. 578) ...									
28M/5381	A16Y/QS					1	—	C	
28M/767	A16Y/CS					1	—	C	
Nut, slotted, $\frac{5}{8}$ " BSF									
Nut, slotted, 2 BA ...									
28P/5045	AGS784/21					1	—	C	
Pin, split, $\frac{1}{8}$ " dia. x $1\frac{1}{2}$ " long									
28P/5032	AGS784/3					1	—	C	
Pin, split, $\frac{1}{16}$ " x 1" long									
Washer, for $\frac{5}{8}$ " BSF bolt ...									
28W/3071	AGS160/C					1	—	C	
Washer, 2 BA ...									
ATTACHMENT FITTINGS, OUTBOARD AILERON TO OUTER MAINPLANE AT RIB No. 33, PORT AND STARBOARD, (F5430)									
1/73									
Consisting of :—									
2665	3F5430					1	S1	C	
Bolt, hex.hd, $\frac{3}{8}$ " BSF x 2.1" long, aileron hinge									
13543	2F5430					2	L40	C	
Bush, for bolt (Pre Mod. 578) ...									
5534	5F5430					2	L40	C	
Bush, for bolt (Mod. 578) ...									
28M/772	A16Y/JS					1	—	C	
Nut, slotted, $\frac{3}{8}$ " BSF									
28P/5032	AGS784/3					1	—	C	
Pin, split, $\frac{1}{16}$ " x 1" long									
13211	3G1384					2	S1	C	
Spacer for 2BA bolt ...									
28W/3074	AGS160/F					1	—	C	
Washer, $\frac{3}{8}$ " ...									
ATTACHMENT FITTINGS, OUTER TO INNER MAINPLANE									
(See Complementary Items Main Planes—Inner Main Plane)									

MAIN PLANES
OUTER MAIN PLANE

Ref. No.	Part No.	Description				No. off	Matl. Spec.	Cl. of St.	Plate and Illust'n No.
		1	2	3	4			M.R.	
SUMMARY OF STOCK ITEMS USED ON OUTER MAINPLANE ASSEMBLY									
28D/12512	A25/1C	Bolt,	2	BA x .55" long	...	14	—	C	
28D/7572	A25/3E	Bolt,	hex.hd,	1/4" BSF	...	22	—	C	
28D/11447	AS1243/6B	Bolt,	csk.hd,	4 BA	...	25	—	C	
28D/8456	AS1882/1C	Bolt,	csk.hd,	2 BA	...	6	—	C	
28M/5316	A16Y/CP	Nut,	2	BA...	...	62	—	C	
28M/756	A16Y/EP	Nut,	1/4"	BSF	...	8	—	C	
	TUCKER								
28Q/9273	TLP/D/BS422	Rivet,	pop. dome	(5SS3123)	...	1970	—	C	
	TUCKER								
28Q/9275	TLP/D/BS424	Rivet,	pop. dome	(6SS3123)	...	86	—	C	
	TUCKER								
28Q/9277	TLP/D/BS429	Rivet,	pop. dome	(7SS3123)	...	40	—	C	
	TUCKER								
28Q/9271	TLP/D/BS419	Rivet,	pop. dome	(4SS3123)	...	90	—	C	
28W/3072	AGS160/D	Washer	27	—	C	
28W/8516	AS470/C	Washer,	2	BA, 1 3/8" dia....	...	14	—	C	

SHACKLETON Mk. 2

MAIN PLANES

WING TIPS

Ref. No.	Part No.	Description				No. off	Matl. Spec.	Cl. of St.	Plate and Illust'n No.	
		1	2	3	4			M.R.		
69 70	1F5777	TIP WING ASSEMBLY, PORT				1	—	A	56/132	
	2F5777	TIP WING ASSEMBLY, STARBOARD ...				1	—	A	56/133	
(Complementary parts, e.g., inter-component attachments are listed at the end of the main plane outer)										
2598	5F5516	END SWEEP, PORT, GROUP				1	—	C	56/134	
			Spares for :—							
			Consisting of :—							
	15F5516	End, sweep	1	DTD610		
17F5516	Piece, packing	1	Hardwood			
19F5516	Piece, packing	1	Hardwood			
2599	6F5516	END SWEEP, STARBOARD, GROUP ...				1	—	C	56/135	
			Consisting of :—							
	16F5516	End sweep	1	DTD610		
	18F5516	Piece, packing	1	Hardwood		
20F5516	Piece, packing	1	Hardwood			
2388	1F5815	FAIRING, FOR RESIN LAMPS, PORT, GROUP				1	—	C	56/136	
2389	2F5815	FAIRING, FOR RESIN LAMPS, STARBOARD, GROUP				1	—	C	56/137	
13013	3SS3158	Screw, csk.hd, 120°, 2 BA x $\frac{3}{8}$" long... ..				16	S1	C	56/138	

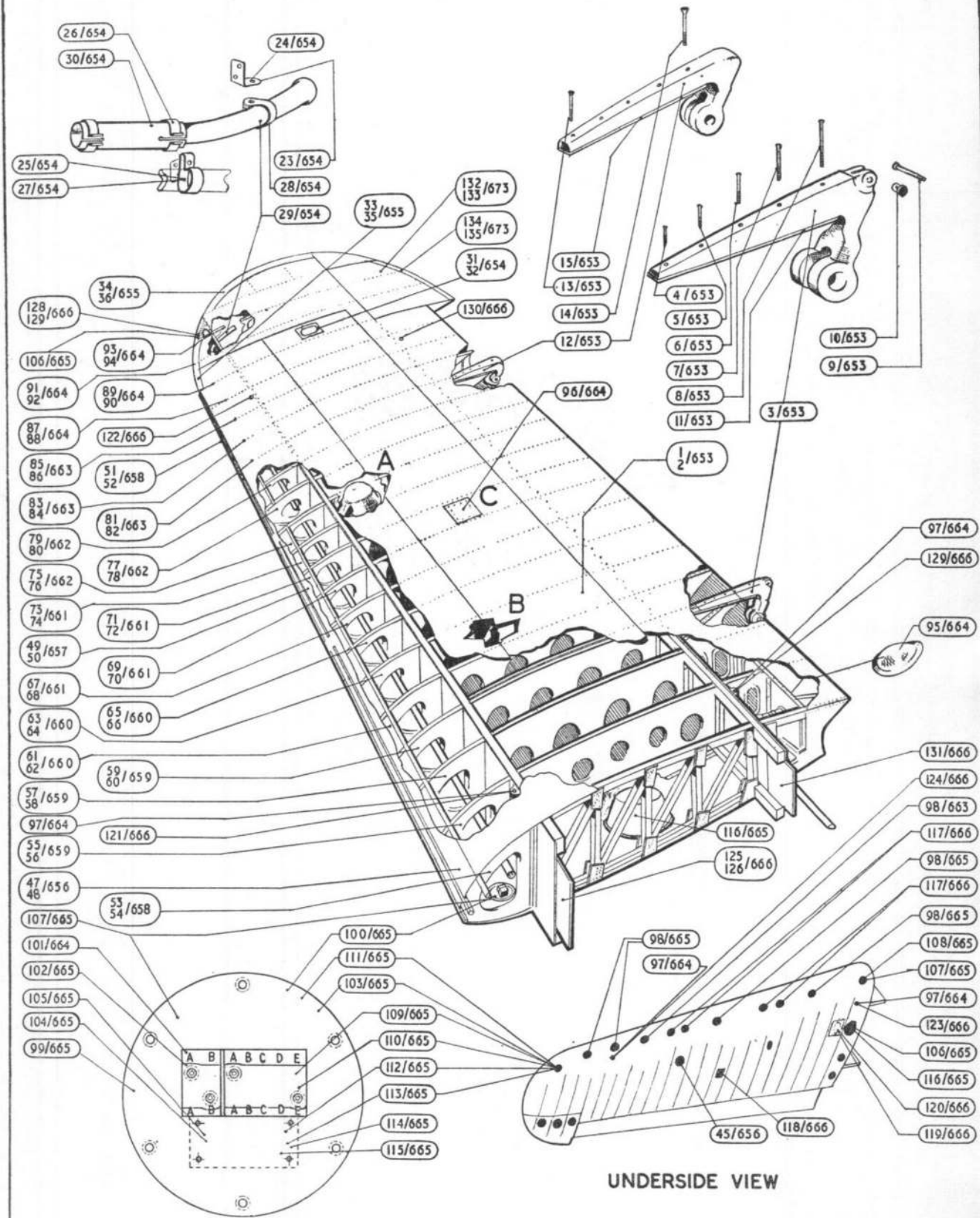

OUTER MAIN PLANE (I)

STATION 10
10/24/2001



STATION 10
10/24/2001

STATION 10
10/24/2001



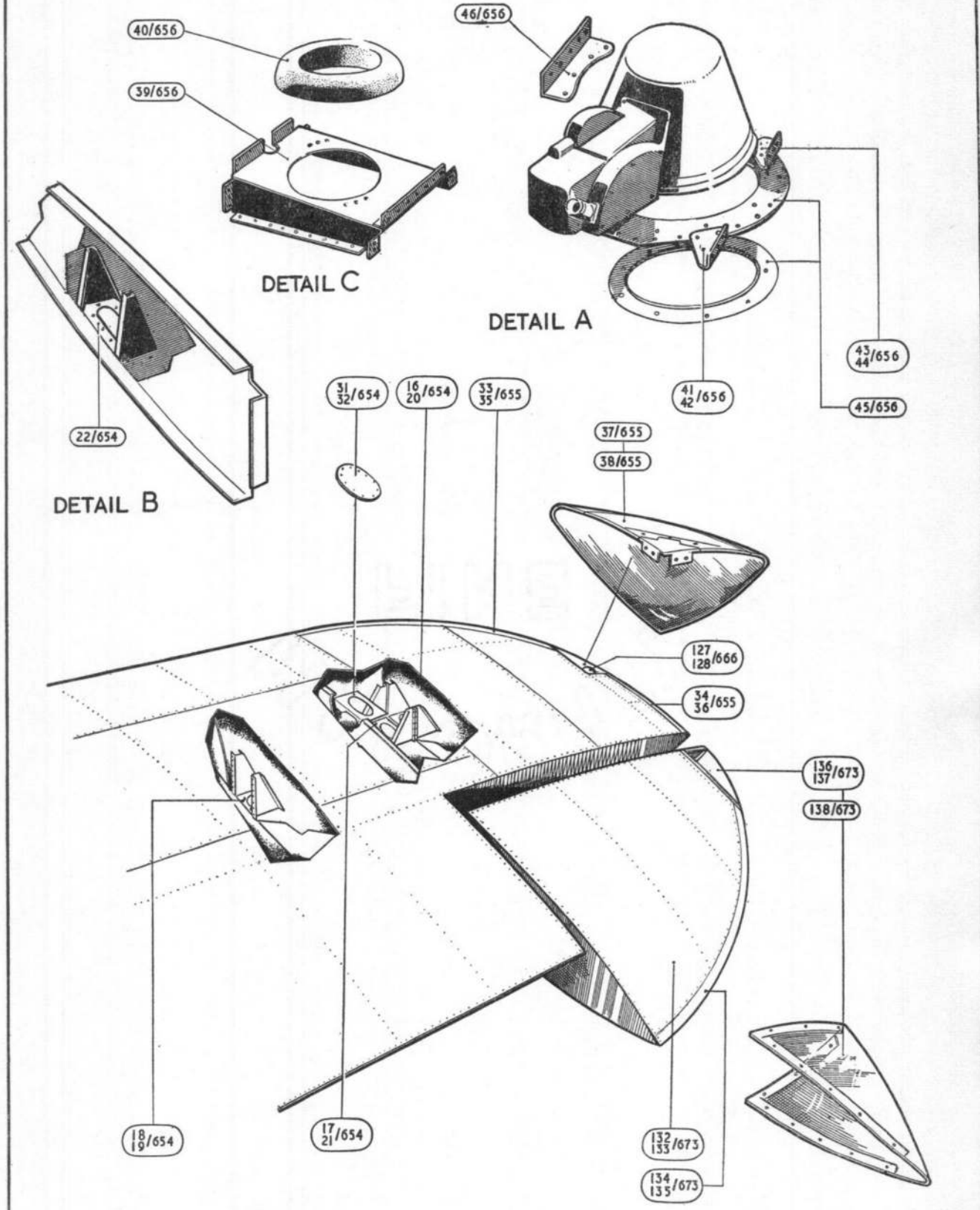

OUTER MAIN PLANE (2)

22-01-27-19
L. ON 3-1-201

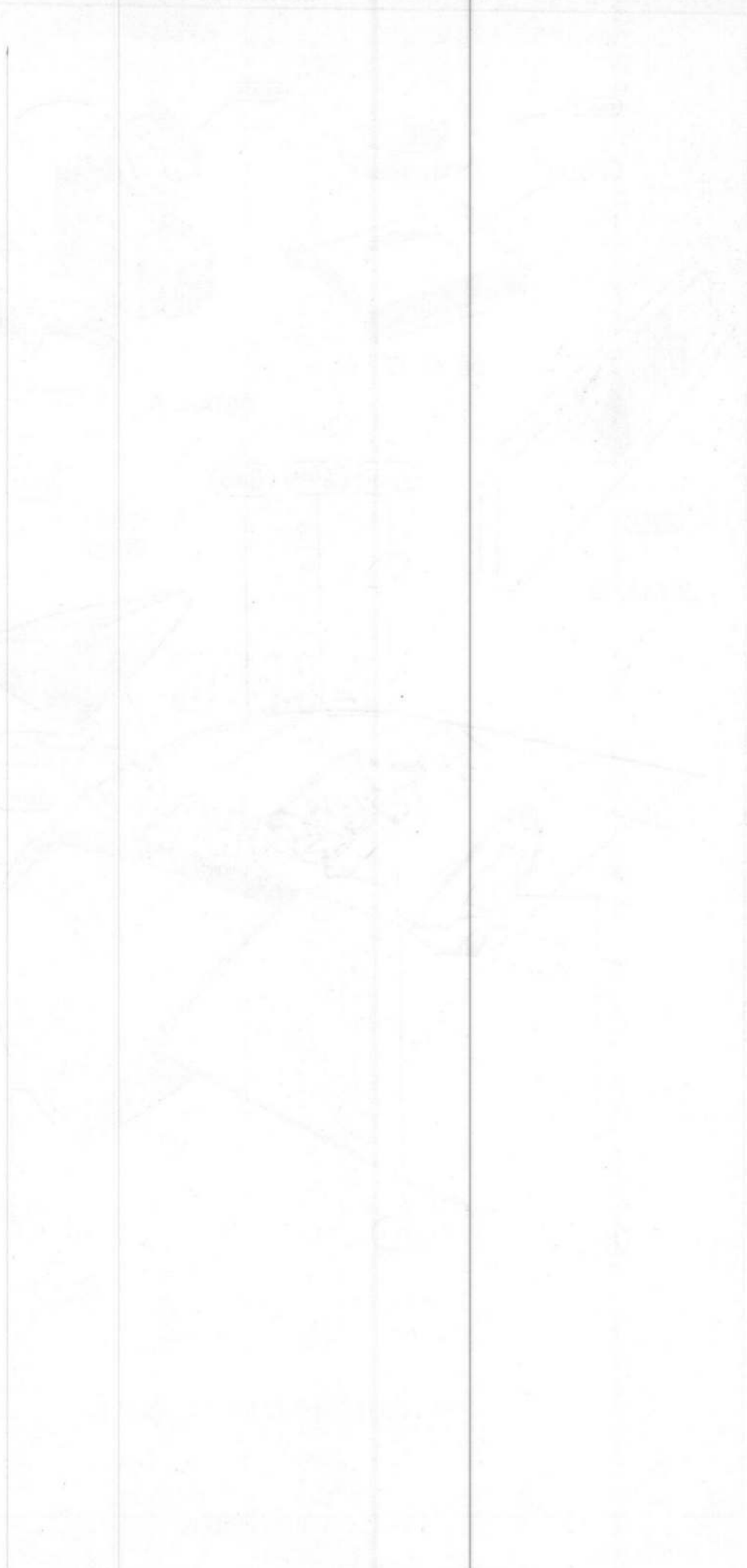

This file was downloaded
from the RTFM Library.

Link: www.scottbouch.com/rtfm

Please see site for usage terms,
and more aircraft documents.

