

Chapter 2

FLOW DISTRIBUTOR, TYPE FD.17 SERIES and FD.29 SERIES

LIST OF CONTENTS

	Para.		Para.
<i>Introduction</i>	1	<i>Installation</i>	10
<i>Description</i>		<i>Inhibiting and packing</i>	11
<i>General</i>	4	<i>Servicing</i>	12
<i>Operation</i>	9		

LIST OF ILLUSTRATIONS

	Fig.		Fig.
<i>Sectioned view of flow distributor</i>	1	<i>Schematic diagram of flow distributor</i>	2

Introduction

1. The flow distributor is designed to meter the fuel evenly under all conditions on an engine employing multiple burners and can be used with any type of burner. The only difference between the F.D.17 series and the F.D.29 series is in the position of the fuel inlet.

2. When used with "Simplex" and "Duplex 2" burners it functions essentially as a flow equaliser, the effects of manifold head on "Simplex" type burners being overcome by the fact that each burner is connected directly to the unit. With "Duplex 3" burners it

operates as a splitter (or pressurising) valve and corrects recovery pressure variations as all main flow passages are separate, the primary flow being tapped off the inlet supply.

3. On systems employing fuel-air ratio controls it can be arranged to produce a flow to any burner which is very nearly proportional to pressure.

DESCRIPTION

General

4. The distributor, illustrated in fig. 1 and 2, consists essentially of a spring-loaded

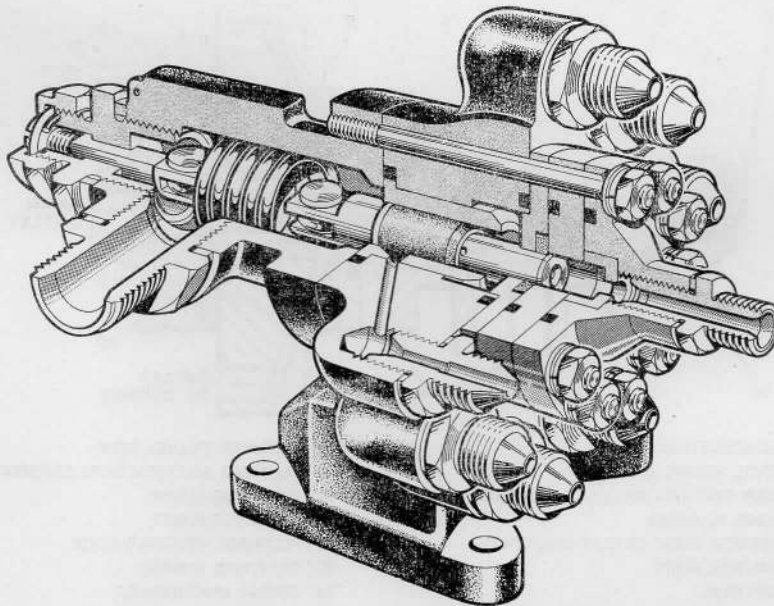

Fig. 1. Sectioned view of flow distributor

plunger (4) operating in a closely-fitting cylindrical metering sleeve (10) in the body casting (6). A carbon sleeve (9) is cemented to the plunger to reduce 'stiction' and minimise hysteresis; the carbon portion extends almost to the upstream end of the steel plunger, the extremity of this forming the metering edge (12) which controls the flow to the burners.

5. Specially-shaped tapering slots (11) in the wall of the metering sleeve are uncovered progressively by the plunger metering-edge as the plunger moves under the influence of fuel pressure. The metering slots terminate in drillings through the wall of the sleeve and communicate with drillings (5) which transfer the fuel to the delivery ports connected to the burners, the number of metering slots depending upon the number of burners to be supplied in individual engine installations.

6. Each slot, therefore, supplies an individual burner with a metered flow of fuel and, if desired, differentiation in flow can be applied to suit special requirements of certain burner positions; such differentiation is obtained either by calibrating the appropriate metering slots during manufacture or by fitting specially-calibrated delivery unions to the appropriate distributor outlet ports.

7. The tail of the metering plunger beyond the carbon sleeve is reduced in diameter to form a pilot and operates in a carbon sealing

bush (7) which guides the plunger tail and also seals against leakage from the pressure-balancing chamber below the carbon portion of the plunger. A small cross-drilling through the plunger pilot communicates with an axial drilling (3) running from the pressure end of the plunger; this drilling pressure-balances the plunger and prevents 'hydraulic' by any fuel leaking between the plunger and metering sleeve wall.

8. Any leakage past the carbon seal is conducted through the plunger travel stop (8) and returned through the drain outlet to pump suction for re-circulation. The proportion of fuel flow relative to fuel pressure is determined by the calibration of the control spring (13) whilst the opening point at which fuel commences to flow to the burners is related to fuel input pressure by the adjustment screw (1) on the end of the spring housing (2). This adjustment screw enables the operating range of the unit to be varied; rotating the screw moves the spring anchorage (14) in or out and thereby alters the spring loading.

OPERATION

9. At low throttle valve delivery pressures the plunger uncovers only a small portion of the metering slots and at these low flows the pressure drop across the slots is sufficient to overcome all other effects and equalize the flow to all burners. Increased inlet pressures will cause the plunger to move further into

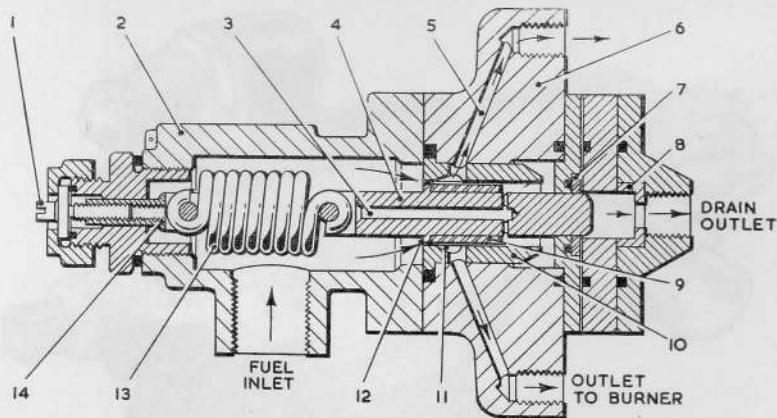

- | | |
|-------------------------------------|---------------------------------------|
| 1 RANGE ADJUSTING SCREW | 8 PLUNGER TRAVEL STOP |
| 2 CONTROL SPRING HOUSING | 9 PLUNGER ANTI-STICTION CARBON SLEEVE |
| 3 PLUNGER PRESSURE-BALANCE DRILLING | 10 METERING SLEEVE |
| 4 METERING PLUNGER | 11 METERING SLOTS |
| 5 DISTRIBUTOR BODY OUTLET DRILLINGS | 12 PLUNGER METERING-EDGE |
| 6 DISTRIBUTOR BODY | 13 CONTROL SPRING |
| 7 CARBON SEAL | 14 SPRING ANCHORAGE |

Fig. 2. Schematic diagram of flow distributor

RESTRICTED

the metering cylinder until the slots become fully uncovered; under these conditions the pressure drop across the slots is less and with any type of burner installation equalization of flow will depend upon the accuracy with which the burner set is matched.

INSTALLATION

10. The unit is bolted through its mounting flange to the side of the engine, forming a junction between the main fuel delivery pipe from the control box via the high pressure filter and the individual pipes leading to the burners. For complete installation details refer to the relevant aero-engine Air Publication.

INHIBITING AND PACKING

11. The unit should be thoroughly flushed through and inhibited in accordance with

the detailed information contained in A.P. 4471A 'The preservation of aero-engines, engine change units, accessories, propellers and associated equipment'. Fit dust caps to all connections and pack in a suitable container.

SERVICING

12. Once the unit is installed on an engine, no servicing is normally necessary except for regular inspection of the pipes and connections for signs of leakage. No leakage is permissible.

13. In the event of leakage disconnection of the pipes will be necessary for tracing and rectifying and at all times when the pipes are again connected the fuel system must be bled to expel all air. The procedure for bleeding the fuel system is described in the relevant aero-engine Air Publication.

RESTRICTED

This file was downloaded
from the RTFM Library.

Link: www.scottbouch.com/rtfm

Please see site for usage terms,
and more aircraft documents.

