

**Chapter 6****AIR-FLOW CONTROL SPEED-SIGNAL TRANSMITTER,  
TYPE ACA 101****LIST OF CONTENTS**

	<i>Para.</i>
<i>Introduction</i> ... ..	1
<i>Description</i> ... ..	3
<i>Rotor assembly</i> ... ..	6
<i>Hinge body</i> ... ..	11
<i>Hinge plate assembly</i> ... ..	12
<i>Operation</i> ... ..	16

**LIST OF ILLUSTRATIONS**

	<i>Fig.</i>
<i>External view of air-flow control speed-signal transmitter</i> ...	1
<i>Cutaway view of transmitter</i> ... ..	2
<i>Functional diagram</i> ... ..	3

**RESTRICTED**

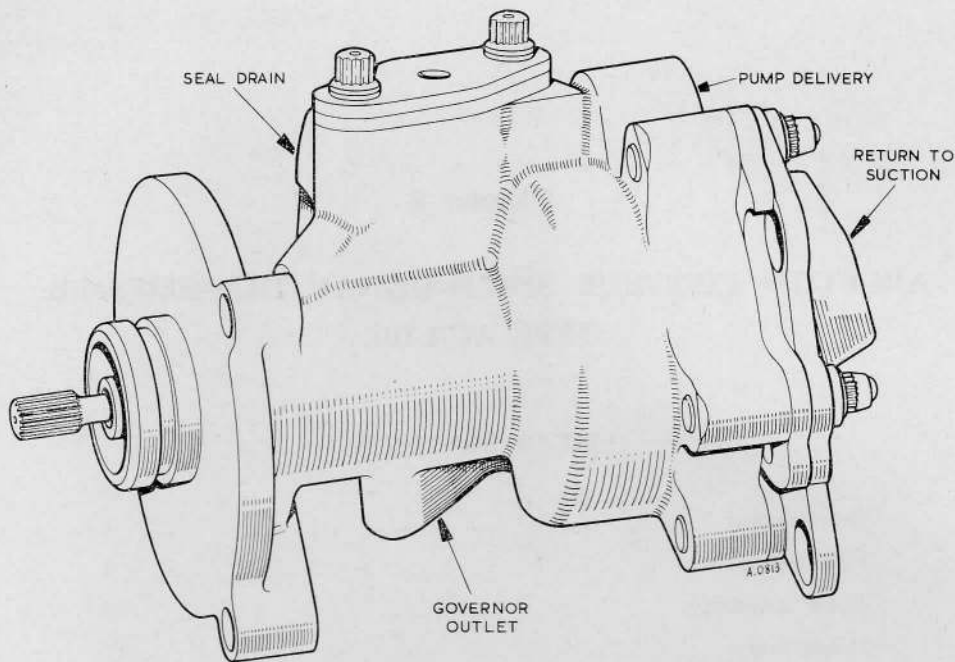

Fig. 1. External view of air-flow control speed-signal transmitter

### Introduction

1. Air approaching the H.P. compressor must be at an angle appropriate to engine speed, and this is achieved by variable-angle inlet guide vanes under the control of an airflow regulator.

2. The purpose of the air-flow control speed-signal transmitter is to pass to the regulator a fuel pressure that is a measurement of engine speed, thereby causing the inlet guide vanes to assume an angle that is also a measurement of engine speed.

### Description (fig. 2 and 3)

3. The unit consists of a housing containing a cylindrical rotor assembly which is driven by the H.P. compressor shaft and which runs completely immersed in fuel supplied, via a filter and a restrictor orifice of fixed size, from the H.P. fuel pump delivery.

4. The signal pressure for operation of the airflow control regulator is derived by varying the degree of restriction imposed upon

the input flow in passing through a second orifice from the exterior to the interior of the rotor, and from thence to the L.P. fuel pump inlet.

5. This varying restriction is obtained by using a weighted hinge-plate assembly which is pivoted to (and therefore rotates with) the rotor assembly, the free end of the hinge plate being in close proximity to the orifice. Rotation subjects the hinge plate to a centrifugal loading that is a measurement of engine speed, and this loading determines the degree of restriction and hence the signal pressure.

### Rotor assembly

6. The rotor assembly runs within a carbon bearing in the housing and has the drive transmitted to it by a serrated quillshaft; a plug fitted at the inner end of the rotor stem carries two rubber seals which prevent the loss of signal pressure past the quillshaft.

7. Leakage of fuel from the driving end is prevented by a spring-loaded carbon face-

**RESTRICTED**

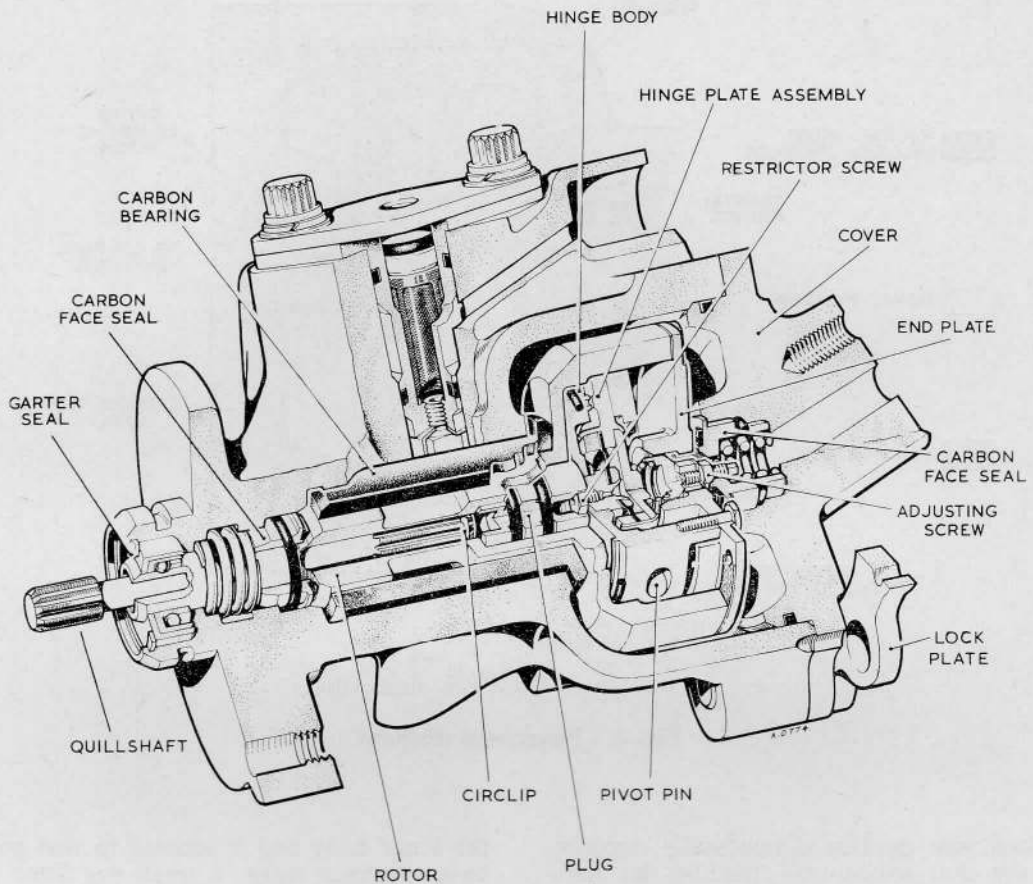

Fig. 2. Cutaway view of transmitter

seal against which the rotor stem rotates; at the opposite end, another seal of this type prevents the association of signal pressure with the fuel passing to pump suction. Engine oil is prevented from entering the unit by a garter seal fitted at the driving end.

8. An end plate is bolted to the rotor and has secured to it a weight which is dowelled into position to counterbalance the weight attached to the hinge-plate assembly; the rotor is therefore dynamically balanced. The hinge body, to which the hinge-plate assembly is pivoted, is also secured to the end plate and aligned by dowels.

9. Rubber seals fitted between the end plate and the rotor, and between the hinge body and rotor, prevent the association of signal pressure with fuel passing to pump suction.

10. At the centre of the end plate an adjusting screw is fitted which determines the loading of a spring acting against the hinge-plate assembly; this spring loading sets a datum for the signal pressure.

#### Hinge body

11. The hinge body is slotted to receive the hinge-plate assembly which pivots on a hinge pin, and the variable-orifice insert is

**RESTRICTED**

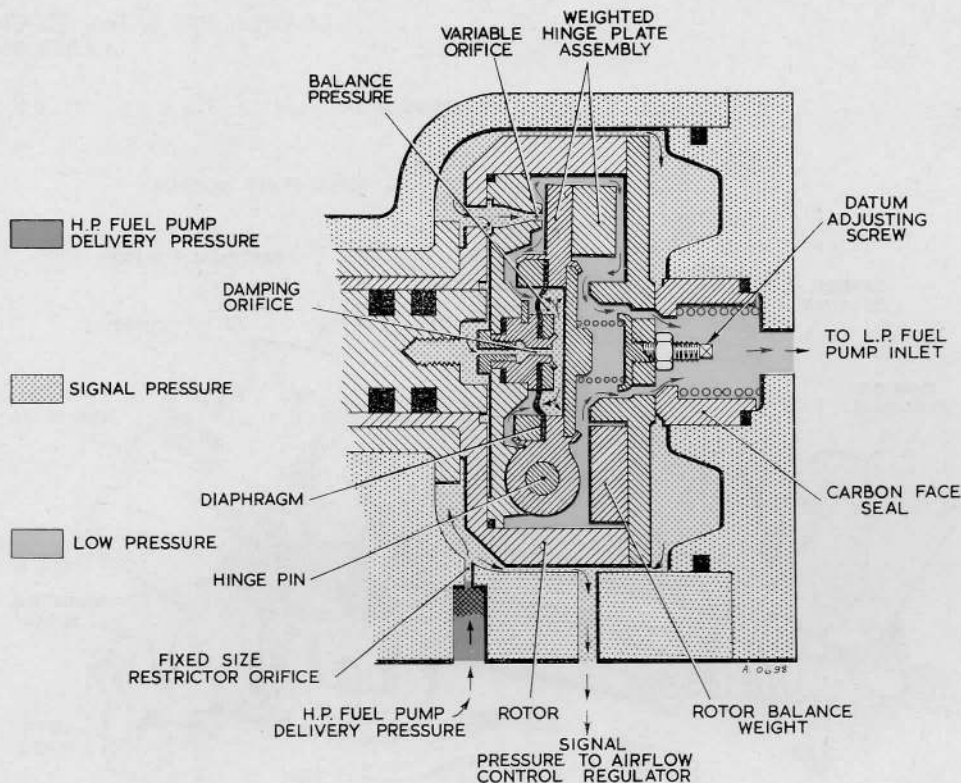

Fig. 3. Functional diagram

brazed into position diametrically opposite to the slot; two dowels fitted in the body register with dowel holes in the end plate.

#### Hinge-plate assembly

12. The hinge-plate assembly consists of a hinge plate and a diaphragm; two needle-roller bearings are fitted to reduce hysteresis when the hinge plate is pivoting, and diametrically opposite to these an insert is brazed into position to form a valve surface with the variable-orifice insert. A weight is also secured to the free end of the lever and dowelled into position; this dowelling of the two weights not only counterbalances the rotor, but also ensures that there is no relative movement of the weights (which would cause irregularities of the signal pressure).

13. The diaphragm is held in position by a plate and a disc which are themselves retained by swaging. At the centre of the diaphragm a restrictor is fitted; this enters

the hinge body and is secured to that part by a restrictor screw; a small peg fitted in the restrictor engages with a slot in the hinge body to prevent the diaphragm from twisting when the restrictor screw is tightened on assembly.

14. Signal pressure is in communication with the chamber formed by the diaphragm and the disc, and balances the centrifugal loading on the hinge plate, thus giving controlled performance.

15. A rubber seal fitted between the restrictor and the hinge body prevents the association of signal pressure with fuel passing to pump suction.

#### Operation (fig. 3)

16. Fuel is fed to the unit from the H.P. fuel pump and passes through the filter and fixed-size restrictor orifice into the chamber

**RESTRICTED**

containing the rotor. This fuel is at pump delivery pressure on entering the unit, but a pressure drop is incurred in passing through the restrictor orifice. The only outlet from the rotor chamber is via the variable orifice in the hinge body.

**17.** The pressure in the rotor chamber (i.e. the signal pressure) depends upon the relationship between the pressure drops across the fixed-size orifice and the variable orifice. therefore any adjustment to the pressure drop across the variable orifice will modify the signal pressure.

**18.** In operation, the variable-orifice pressure drop is regulated by the hinge plate, which is sensitive to engine speed and signal pressure as follows:

(1) Engine speed, by way of mechani-

cal centrifugal loading which, as the speed increases, reduces the gap between the hinge plate and the orifice, therefore increasing the pressure drop.

(2) Signal pressure opposes the centrifugal loading by acting within the diaphragm chamber. When the force produced by the signal pressure equals the closing force acting on the hinge plate at any particular speed, the hinge plate is balanced in a position which ensures that the signal pressure is proportional to  $N^2$  (i.e. the square of the engine speed).

**19.** The restricted passage leading to the diaphragm chamber damps out pump pulsations and any tendency for the hinge plate assembly to vibrate under adverse conditions, thus ensuring a stable signal pressure at any given speed.

This file was downloaded  
from the RTFM Library.

Link: [www.scottbouch.com/rtfm](http://www.scottbouch.com/rtfm)

Please see site for usage terms,  
and more aircraft documents.

