

Chapter 6

REHEAT FUEL CONTROL UNITS

RCU.1/1A and 2/2A

LIST OF CONTENTS

	<i>Para.</i>		<i>Para.</i>
<i>Introduction</i>	1	<i>Installing and servicing</i>	12
<i>Construction and operation</i>	7	<i>Inhibiting</i>	14

ILLUSTRATION

	<i>Fig.</i>
<i>Functional diagram</i>	1

Introduction

1. In order to augment the normal maximum thrust of the engine when extra power is required for short periods, e.g., combat conditions, a reheat fuel system is used whereby an independent fuel flow is delivered to a reheat manifold in the engine. The resulting higher temperature increases the gas velocity and hence the engine thrust.

2. In this particular form of reheat application, a small amount of fuel is injected immediately in front of and immediately behind the engine turbine. The flame produced by this injection ignites the main reheat fuel flow in the reheat fuel duct; this is known as the hot-streak method of ignition.

3. The control unit supplies the correct quantity of fuel when reheat is selected; this is actuated by a shut-off cock situated in the fuel pump delivery line and a nozzle control pressure switch which opens the reheat manifold to receive the extra fuel supply.

4. The system therefore has to perform the following functions:—

(1) Provide means of ignition of the reheat fuel flow at the correct time relative to the reheat nozzle opening.

(2) Automatically control the reheat fuel flow in order to maintain engine thrust at a desired value, irrespective of altitude.

5. These requirements are obtained in the following manner:—

(1) During normal engine running, fuel pump delivery pressure is fed to the unit via the connection (5) which by-passes the shut-off cock. An accumulator is then charged in readiness for selection of reheat ignition.

(2) When selected, the shut-off cock is opened and the fuel is supplied to the unit at the connection (20). Fuel then passes through the control to be regulated by means of a metering orifice and a servo throttling valve proportional to compressor delivery pressure (P2), and is then delivered to the reheat manifold.

(3) After a delay of approximately $1\frac{1}{2}$ seconds, a pressure signal is fed to the nozzle control pressure switch and the nozzle commences to open. The accumulator charge is then delivered to the engine via the hot streak injectors and reheat ignition is achieved.

6. The types RCU.1/1A and 1/2A are identical except for the pressure-drop assemblies, the adjustment mounting being located at different attitudes.

Construction and operation

7. Basically the unit comprises an air-fuel ratio control, a pressure-drop sensing device, a servo throttle valve and an accumulator which stores the fuel injection charge for reheat ignition.

8. The A.F.C. body houses a fuel flow metering plunger (13) which varies the area of an orifice (14) in the fuel supply to the reheat burner manifold. The position of the plunger and consequently the fuel flow is controlled by the pressure drop across the plunger balanced against the influence of a capsule (12) sensing compressor delivery pressure. The metering plunger is also moved by a change in the control entry pressure (22) balanced against the servo pressure (24) which is modified by the capsule through a cantilever (11) carrying the metering plunger

servo valve (25). At the same time the pressure drop across the plunger orifice is sensed by a pressure-drop unit which, through its piston (17), rocker lever (15), and valve (18) acts upon the servo throttle (23) and so regulates the fuel delivery to the burners. A control trimming adjustment (10) and a pressure-drop adjustment (16) are provided and are set on the test rig to maintain engine thrust boost at a predetermined value, irrespective of altitude.

9. The purpose of the accumulator (26), timing valve (3), and relay valve (8) is to deliver a charge of fuel to the hot-streak injectors in order to achieve ignition of the reheat fuel delivered from the A.F.C.

10. When the shut-off cock is opened, i.e. reheat selected, fuel pressure is fed to the annulus (28) and via the timing jet (2) to the front of the timing valve (3). The pressure in front of the valve rises and moves the valve rearwards until the annulus (28) is uncovered, whereupon the valve moves rapidly to its rear position. At the same time the relay valve (8) moves until the port (4) is uncovered and is fed from the annulus (28) with shut-off cock timing pressure. Conversely the port (6) is disconnected from the port (5) to connect to the charge outlet (9). The accumulator piston (26) assisted by hydraulic pressure and its spring is then moved sharply forward to deliver its fuel charge to the hot-streak injectors. The timing jet orifice is of a selected size so that there is approximately $1\frac{1}{2}$ seconds delay between the opening of the shut-off cock and the discharge of the igniter fuel. The accumulator charge is approximately $\frac{1}{3}$ pint the duration of supply 0.3 seconds and commences at about the same time as the manifold reheat nozzle begins to open. This sequence ensures that ignition does not commence until full reheat flow is available at the manifold and that combustion is not fully established until the nozzle is open.

11. When the shut-off cock is closed, i.e. reheat switched off, the relay valve (8) returns under the influence of its spring, and the displaced fluid is passed to pump inlet via the drain jet (1). The timing valve then returns, and the displaced fluid is passed to the fuel pump inlet via the drain and timing jets. Conversely the accumulator piston (26) moves back and the accumulator is recharged from the fuel pump port (5), the complete cycle being performed within one second of

reheat being switched off. The drilled passage (7) is provided to prevent H.P. fuel leakage when reheat is on.

Installation and servicing

12. The unit is mounted on three studs on the engine. Unions are provided for the following connections:—

- Inlet from shut-off cock
- Outlet to burners
- Inlet from H.P. fuel pump
- Discharge to hot-streak injectors
- Drain to fuel pump inlet
- Pressure to nozzle control pressure switch
- Compressor delivery pressure (P2).

13. When installed on an engine no adjustments are permissible. Periodical checks should be made for leakage and condition of external locking devices.

Inhibiting

14. The unit should be inhibited prior to storage in accordance with the instructions contained in A.P.4471A.

KEY TO FIG. 1

- 1 DRAIN JET
- 2 TIMING JET
- 3 TIMING VALVE
- 4 ACCUMULATOR PORT
- 5 INLET FROM H.P. FUEL PUMP
- 6 INTER-CONNECTING PORT
- 7 ANTI-LEAKAGE PASSAGE
- 8 RELAY VALVE
- 9 IGNITING CHARGE OUTLET
- 10 TRIMMING ADJUSTMENT
- 11 CANTILEVER
- 12 CAPSULE
- 13 METERING PLUNGER
- 14 VARIABLE METERING ORIFICE
- 15 ROCKER LEVER
- 16 PRESSURE-DROP ADJUSTMENT
- 17 PRESSURE-DROP PISTON
- 18 PRESSURE-DROP VALVE
- 19 RESTRICTING ORIFICE
- 20 INLET FOR H.P. FUEL FROM S.O.C.
- 21 SERVO THROTTLE DIAPHRAGM
- 22 A.F.C. ENTRY PRESSURE
- 23 SERVO THROTTLE
- 24 SERVO PRESSURE
- 25 METERING PLUNGER SERVO VALVE
- 26 ACCUMULATOR PISTON
- 27 TO NOZZLE CONTROL PRESSURE-SWITCH
- 28 TIMING PRESSURE ANNULUS
- 29 DRAIN TO PUMP INLET

RESTRICTED

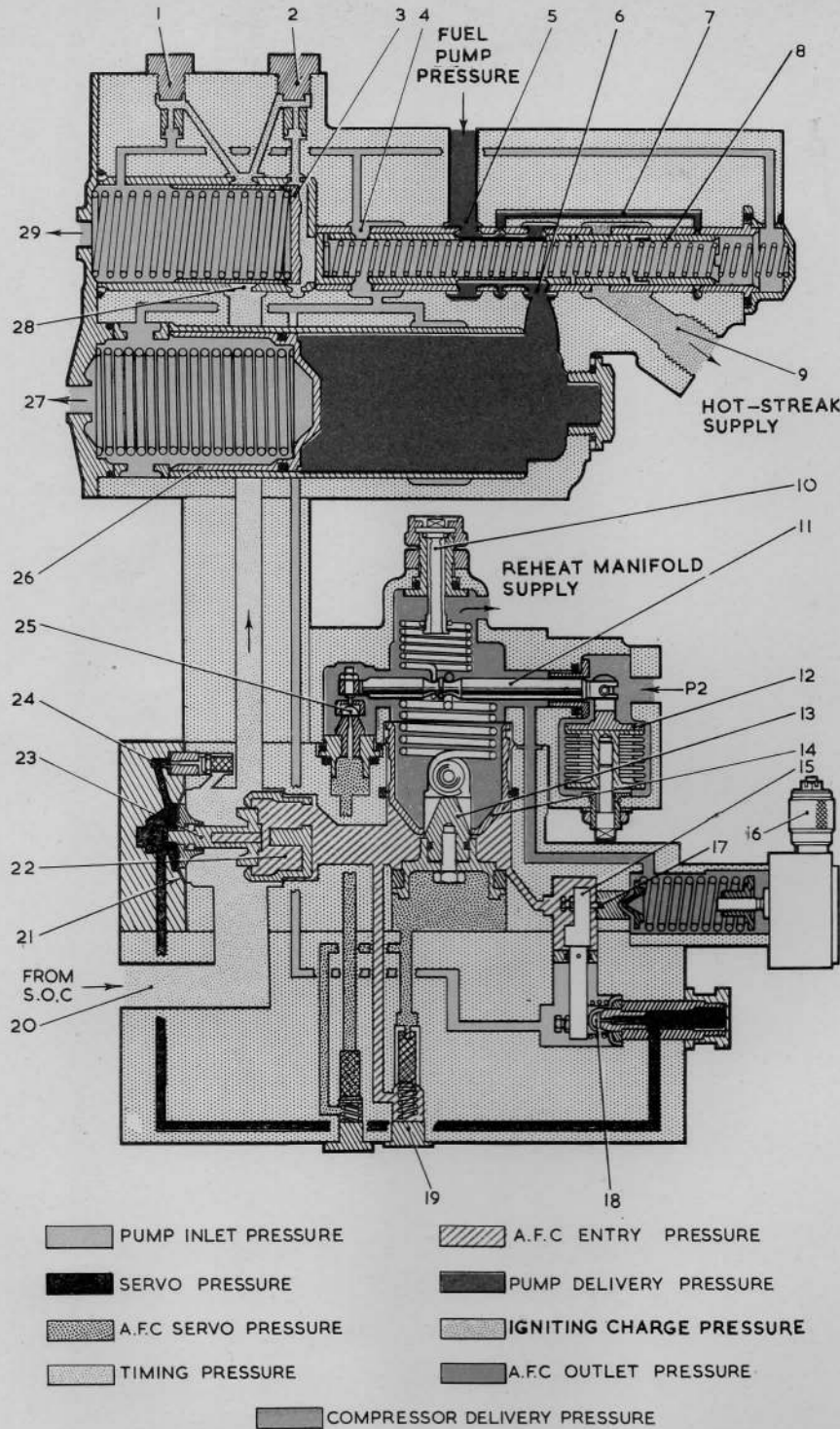

Fig. 1 Functional diagram

RESTRICTED

(A.L. 62, Dec. 58)

This file was downloaded
from the RTFM Library.

Link: www.scottbouch.com/rtfm

Please see site for usage terms,
and more aircraft documents.

