

Chapter I

BAROSTAT, TYPE ACU/M15C

LIST OF CONTENTS

	Para.		Para.
<i>Introduction</i>	1	<i>Reducing valve body with spill valve assembly</i> ...	16
<i>Description</i>		<i>Operation of the barostat under normal conditions</i>	23
<i>General</i>	2	<i>Installation</i>	29
<i>Main casting</i>	5	<i>Inhibiting and packing</i>	30
<i>Main piston assembly</i>	12	<i>Servicing</i>	31
<i>Control valve, capsule stack, capsule canister, stop ring and push rod</i>	13		

LIST OF ILLUSTRATIONS

	Fig.
<i>Sectioned view of barostat unit, type ACU/M15C</i>	1
<i>Simplified schematic view of operation of barostat unit</i>	2

Introduction

1. The barostat, type ACU/M15C described in this chapter is incorporated in De Havilland Goblin Mk. 1 and 2 engines and is essentially a fuel by-pass valve, the setting of which is controlled by the pressure of air at the engine intake. The unit adjusts the pressure of fuel from the high-pressure pump according to the requirements of the engine at different altitudes and speed, and by-passes to the tank all fuel in excess of that required for satisfactory combustion at any given altitude and speed.

DESCRIPTION

General

2. The barostat unit consists of a body casting divided into two main compartments, one housing the spill valve which is loaded by springs against a main piston, and the other containing a barometric capsule stack. The capsule stack operates the control valve to

adjust the fuel flow to or from the space above the piston in such a manner that the position of the piston is dependent upon the length of the barometric capsule.

3. A reducing valve regulates the rate of fuel flow to the control valve system, and a ball type relief valve prevents the pressure from the reducing valve from exceeding a pre-determined maximum.

4. For the purpose of description the unit, which is illustrated in fig. 1, may be divided into the following sub-assemblies:—

- (1) Main casting
- (2) Main piston assembly
- (3) Control valve, capsule stack, capsule canister, stop ring, and push rod assembly
- (4) Reducing valve body with spill valve assembly

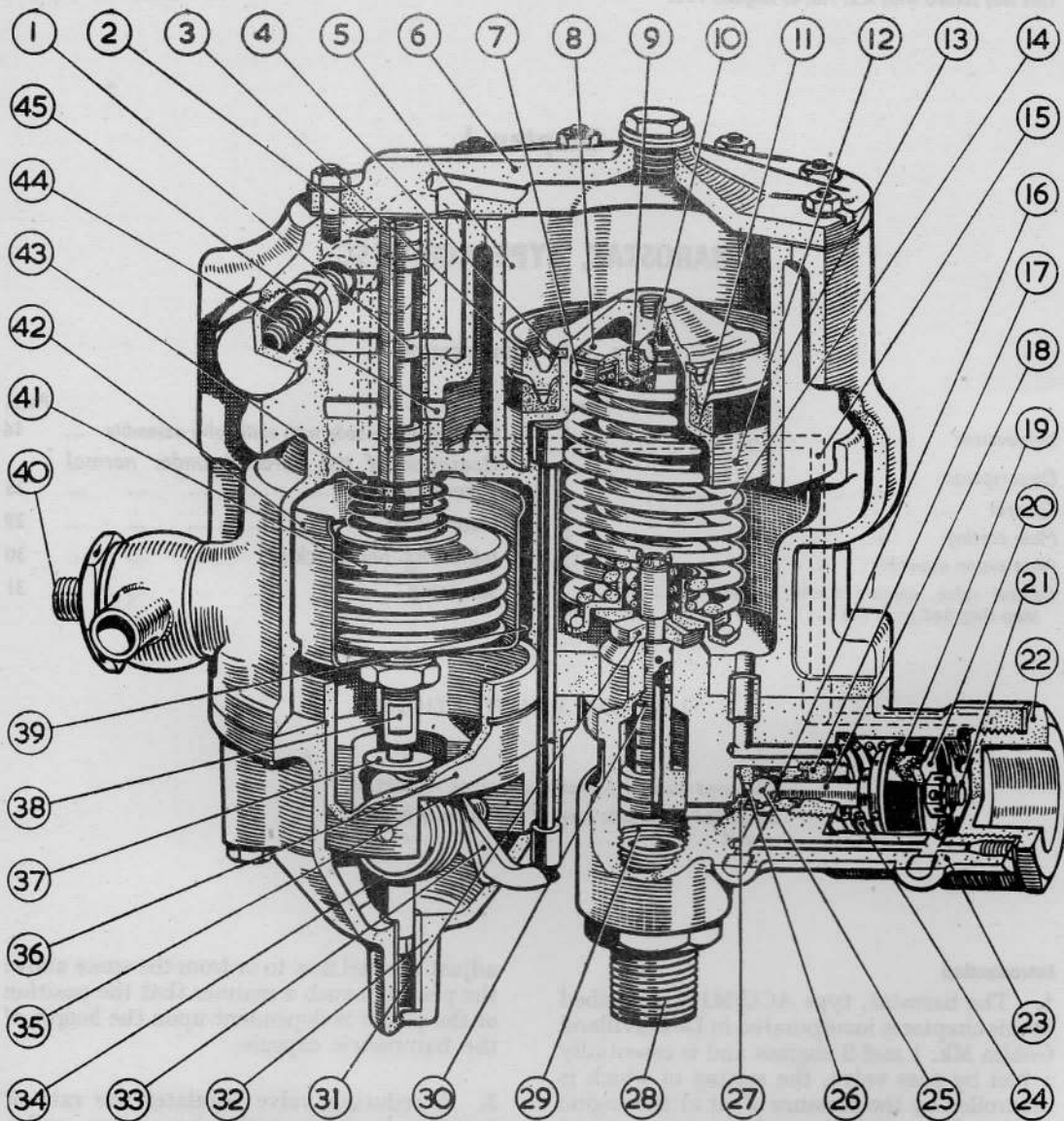

- | | | | |
|----|--|----|-------------------------------|
| 1 | CONTROL VALVE | 23 | REDUCING VALVE BODY |
| 2 | FILTER | 24 | SPRING |
| 3 | RETAINING RING | 25 | BALL FOR REDUCING VALVE |
| 4 | CIRCLIP | 26 | PORT, INLET |
| 5 | MAIN PISTON CHAMBER | 27 | BALL-SEAT |
| 6 | TOP COVER | 28 | FUEL INLET UNION ADAPTER |
| 7 | SPRING CAGE (UPPER) | 29 | INLET CHAMBER |
| 8 | SPRING CARRIER (UPPER) | 30 | SPILL VALVE |
| 9 | BALL HOUSING | 31 | SPHERICAL SEATING |
| 10 | BALL, FOR MAIN PISTON | 32 | CAPSULE CHAMBER BOTTOM COVER |
| 11 | MAIN PISTON SEAL | 33 | ROCKER LEVER |
| 12 | MAIN PISTON | 34 | SPRING, FOR ROCKER LEVER |
| 13 | MAIN PISTON SLEEVE | 35 | PUSH ROD |
| 14 | HELICAL SPRINGS | 36 | STOP RING |
| 15 | PASSAGE BETWEEN REDUCING CHAMBER AND CONTROL VALVE | 37 | ADJUSTING NUT |
| 16 | BALL CAGE | 38 | SPINDLE, FOR CAPSULE CANISTER |
| 17 | RING NUT | 39 | CAPSULE CHAMBER |
| 18 | REDUCING VALVE SPINDLE | 40 | SPILL FUEL OUTLET |
| 19 | REDUCING VALVE PISTON SEAL | 41 | CAPSULE STACK |
| 20 | WASHER | 42 | CAPSULE CANISTER |
| 21 | REDUCING VALVE ASSEMBLY | 43 | SPRING |
| 22 | END PLUG FOR REDUCING VALVE CHAMBER | 44 | SPILL PASSAGE |
| | | 45 | BALL VALVE |

Fig. 1. Sectioned view of barostat unit, type ACU/MISC

Main casting

5. The main body of the barostat is a light-alloy casting consisting of two main chambers one housing the piston assembly, and the other the capsule assembly. A third chamber housing the reducing valve and spill valve assembly is described later (*para.* 16).

6. The top portion of the piston chamber (5) is machined to take the light-alloy piston sleeve (13) in which the piston assembly operates. This sleeve is located at its lower end in a machined portion of the body casting and is retained at the top by the top cover (6). Below the piston sleeve the casting is slightly reduced in diameter, and at the bottom it is bored to locate the cast-iron body (23) for the reducing valve.

7. The underside of the reducing valve body houses the main fuel inlet union (28) and the reducing valve body is retained to the main casting by three studs and nuts.

8. Adjacent to the piston chamber, another compartment (39) in the casting forms an enlarged chamber which accommodates at its lower end the capsule stack (41) and capsule canister (42).

9. Above this chamber the casting is bored to house a sleeve accommodating the control valve (1). The lower end of the capsule chamber is sealed by a light-alloy cover (32) retained by four studs and nuts.

10. Suitable passages (15 and 44) are drilled in the casting to provide communication between the reducing chamber and the control valve, and between the control valve to the spill outlet respectively. The passage (15) accommodates a filter (2) and a spring-loaded ball valve (45) which lifts if a certain pre-determined pressure is exceeded and allows fuel to spill to atmospheric drain.

11. The top of the unit is sealed by a cover with joint washer; this cover is drilled to allow communication between the piston chamber (5) and control valve (1).

Main piston assembly

12. The main piston assembly consists of a brass piston (12) having a synthetic rubber seal (11) of "U" section secured by a brass retaining ring (3) and steel circlip (4). The piston slides in the piston sleeve (13). A

central boss on the underside of the piston crown has a machined spherical recess. This recess accommodates a steel ball (10) and housing (9) in the centre of a steel carrier (8) fitted into a steel upper spring cage (7). Triple helical springs (14) are located between the upper and lower spring cages, the lower cage being carried on a steel spring carrier which in turn rests on the upper face of the spherical seating (31) of the spill valve (30).

Control valve, capsule stack, capsule canister, stop ring and push rod

13. The control valve (1) is a landed steel rod which slides in a sleeve fitted in the body casting. The lower end of the valve is enlarged to form a tappet face which rests on the top of the capsule stack (41). The valve is maintained in contact with the capsule stack by the pressure of a helical spring (43) located between the enlarged face of the control valve and the top of the capsule chamber casting.

14. The capsule stack (41) is housed in a cup-shaped light-alloy canister (42). The base of the canister carries a steel spindle (38) the lower end of which is located in a bearing in the bottom cover (32). This spindle has a threaded portion to accommodate a steel nut (37) which is adjusted during calibration, and secured by a lock-nut.

15. A light-alloy capsule stop ring (36) is fitted into the base of the capsule chamber and carries a spring-loaded steel rocker lever (33), one end of which engages with the steel adjusting nut (37) on the canister spindle, and the other with the lower end of the push rod (35). The push rod passes through the bottom cover flange and main casting, the upper end emerging into the piston chamber to make contact with the underside of the main piston.

Reducing valve body with spill valve assembly

16. The reducing valve body (23) is an L-shaped casting of high grade cast iron and accommodates the main fuel inlet union (28) and the reducing valve assembly (21). It also houses the spill valve (30).

17. A ball valve (25) locates with a steel seat (27) in the base of the reducing valve chamber, and is retained by a brass cage (16) and a slotted brass ring nut (17) having a synthetic rubber seal.

18. The reducing valve is loaded by a spring (24) and comprises a central steel spindle (18) having a shouldered stop against which a circular steel spring plate is located. A synthetic rubber seal (19) has a steel washer fitted on each side (20); these washers are secured by a castellated nut and split pin.

19. The valve spindle projects through the centre of the ring nut, seal, and valve cage. A steel plug (22) seals off the reducing valve chamber and also forms a stop for the valve.

20. The inlet chamber (29) of the reducing valve body houses the spill valve assembly. The spill valve (30) is formed by a steel plunger having an axial hole for approximately two thirds of its length from which radiate drillings through the side walls of the valve.

21. The inner end of the valve carries a steel spherical seating (31), secured by a brass distance piece and screw, and forms the lower location for the piston springs (14).

22. The main fuel inlet adapter (28) is carried in a boss in the lower face of the body.

OPERATION OF THE BAROSTAT UNDER NORMAL CONDITIONS

23. Under normal conditions fuel from the high-pressure fuel pump (*fig. 2*) is admitted to the underside of the spill valve (30) via the inlet passage (29). As the inlet pressure increases and the load of the springs (14) is overcome, the spill valve by-passes fuel, via a return connection (46) to the fuel tank. The loading of the springs is controlled, in accordance with the length of the barometric capsule stack (41), by the position of the piston (12) which is free to slide in its cylinder. The position of the piston is governed by the admission or escape of fuel, as determined by the control valve (1), to or from the space (5) above the piston.

24. Fuel from the inlet (29) is supplied to the control valve (1) through a port (26), thence across the top of the reducing valve piston (19) and through a connecting passage (15).

25. The pressure builds up until it is sufficient to overcome the combined pressure of the spring (24) beneath the reducing valve piston (19) and the fuel pressure on the piston plunger (18), when the plunger is moved to cover the port from the inlet chamber. A state of balance is thus established between the reducing valve and the control valve which is proportional to the fuel pressure at the inlet.

26. Any increase in altitude with a corresponding decrease in barometric pressure allows the capsule stack (41) to expand and move the control valve (1) upwards to connect the space (5) above the main piston with the spill outlet (40). The piston (12), relieved of pressure on its upper side, moves up to reduce the loading of its springs (14) on the spill valve (30), which by-passes excess fuel to the fuel tank.

27. The upward movement of the piston (12) is accompanied by a corresponding downward movement of the control valve (1) through the mechanical linkage (33) and (35) between piston and valve. The spill connection (40) is now cut off and the piston (12) stabilized in its new position.

28. With a decrease in altitude the reverse action takes place; the capsule stack is compressed by the increased barometric pressure and moves the control valve downwards, thus connecting the servo passage from the reducing valve with the space above the piston. This allows a flow of fuel into the space above the piston via the reducing valve, and increases the piston loading on the springs controlling the spill valve.

INSTALLATION

29. The installation of the unit is described in the relevant engine Air Publication.

INHIBITING AND PACKING

30. The inhibiting and packing procedure is described in Vol. 2, Part 3, Section 4, Chapter 1, para. 162 and 163.

SERVICING

31. Once the barostat unit is installed no servicing is necessary except for a constant check of all pipe connections and unions for tightness, as no leakage is permissible.

KEY TO FIG. 2

1 CONTROL VALVE
5 MAIN PISTON CHAMBER
12 MAIN PISTON
14 HELICAL SPRING
15 PASSAGE BETWEEN REDUCING VALVE CHAMBER AND CONTROL VALVE
18 REDUCING VALVE SPINDLE
19 REDUCING VALVE PISTON
24 SPRING

26 PORT, INLET
29 INLET CHAMBER
30 SPILL VALVE
33 ROCKER LEVER
35 PUSH ROD
40 SPILL FUEL OUTLET
41 CAPSULE STACK
46 RETURN CONNECTION TO FUEL TANK

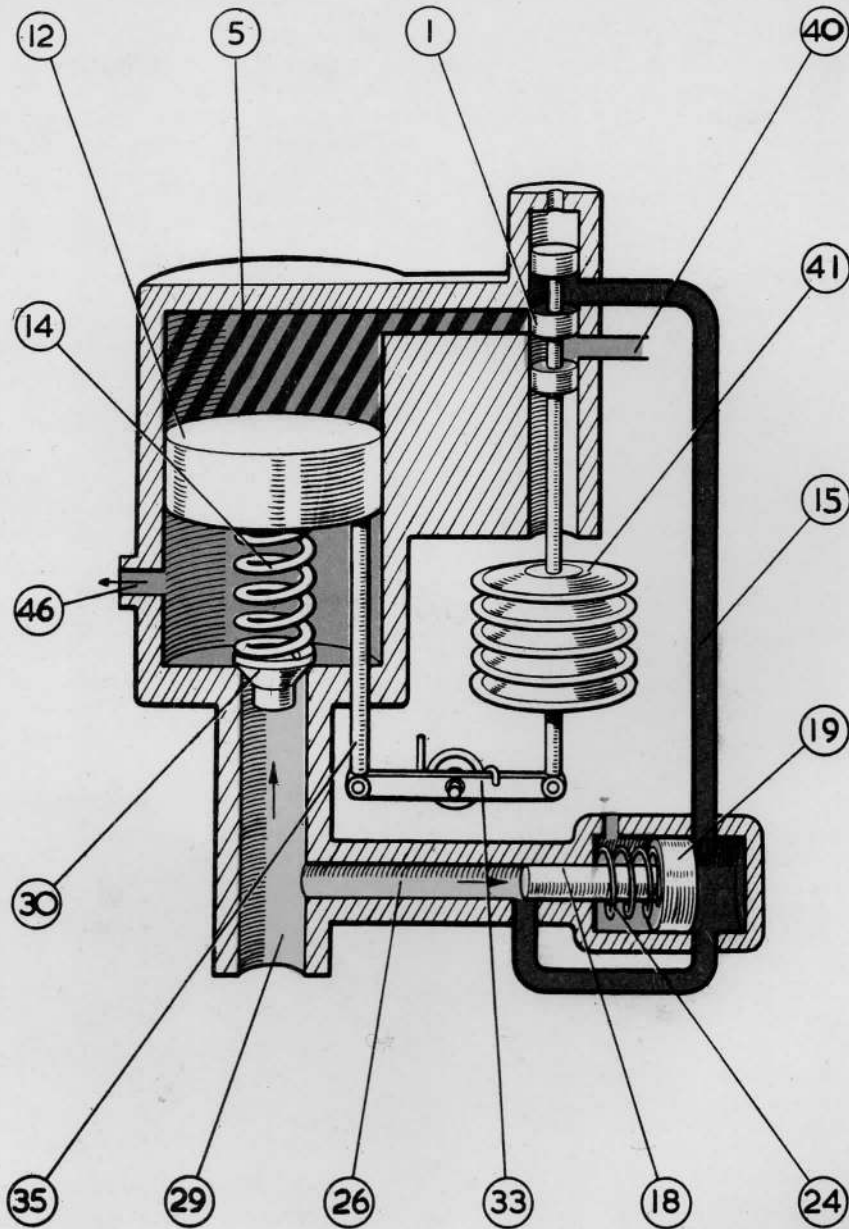



-  INLET PRESSURE
-  SERVO PRESSURE
-  SPILL PRESSURE

FIG.2 SIMPLIFIED SCHEMATIC VIEW OF OPERATION OF BAROSTAT UNIT

This file was downloaded
from the RTFM Library.

Link: www.scottbouch.com/rtfm

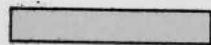
Please see site for usage terms,
and more aircraft documents.

