

## Chapter 3

## SOLENOID VALVES, TYPE SV.4, 5, 7, 12 AND SOL.32

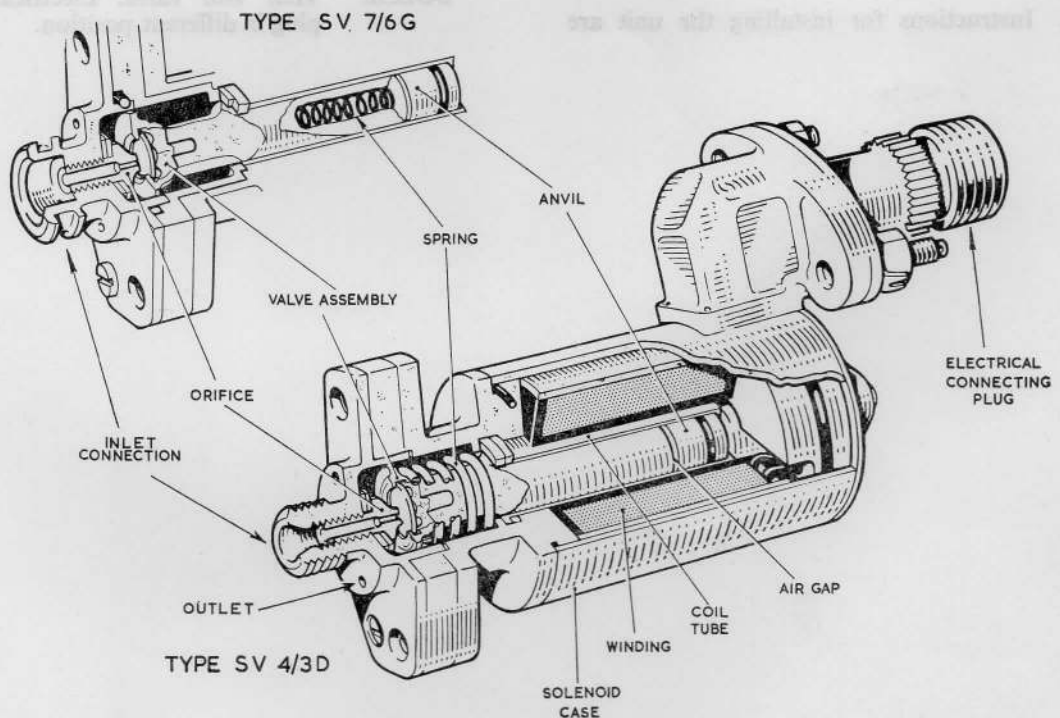

Fig. 1. Solenoid valves, SV. 4/3D and SV. 7/6G

1. The solenoid valves are all similar in construction and operation; the differences are shown in para. 7.

2. To each of the SV. types is added a number and a letter, e.g. SV4/3D, to indicate its particular installation features, and the calibration code to which it must be tested. On the SOL. type the basic number (32) also identifies the installation standard and calibration code.

3. A solenoid valve may be used to control the fuel or air supply for the main fuel system of an engine, or for some subsidiary system such as re-heat or fuel booster system.

4. The solenoid winding is sealed into its cylindrical case and is connected to a two pin electrical plug which is mounted on the outside of the casing. A coil tube passes through the centre of the solenoid and houses a valve assembly. The valve is spring loaded

RESTRICTED

to hold it against the flat face of an orifice which is screwed into the inlet connection. An air gap is provided between the opposite end of the valve and a fixed anvil; this gap is adjustable by washers beneath the orifice head. The flange of the inlet connection is drilled for the attachment of the solenoid valve to its respective unit. Two smaller holes in a boss surrounding the connection form the outlet from the valve chamber.

5. When the solenoid is energised, it exerts a pull on the valve, which overcomes the spring loading and opens the valve to allow fuel or air to pass to its associated unit or to be by-passed to relieve pressure. When the solenoid is de-energised, the spring closes the valve.

6. Instructions for installing the unit are

given in the engine Air Publication. No servicing is required apart from checks on the security of the electrical connections and the mounting bolts.

7. The differences in the types of solenoid valves are as follows :

- SV.4/3D Plate type valve.
- SV.5/4E Half ball valve.
- SV.7/6G Valve assembly counterbored to provide internal spring loading. Orifice housing grooved to take sealing ring. Plate type valve.
- SV.12/8H Half ball valve. Sealing ring in orifice housing.
- SOL.32 Half ball valve. Electrical plug in different position.

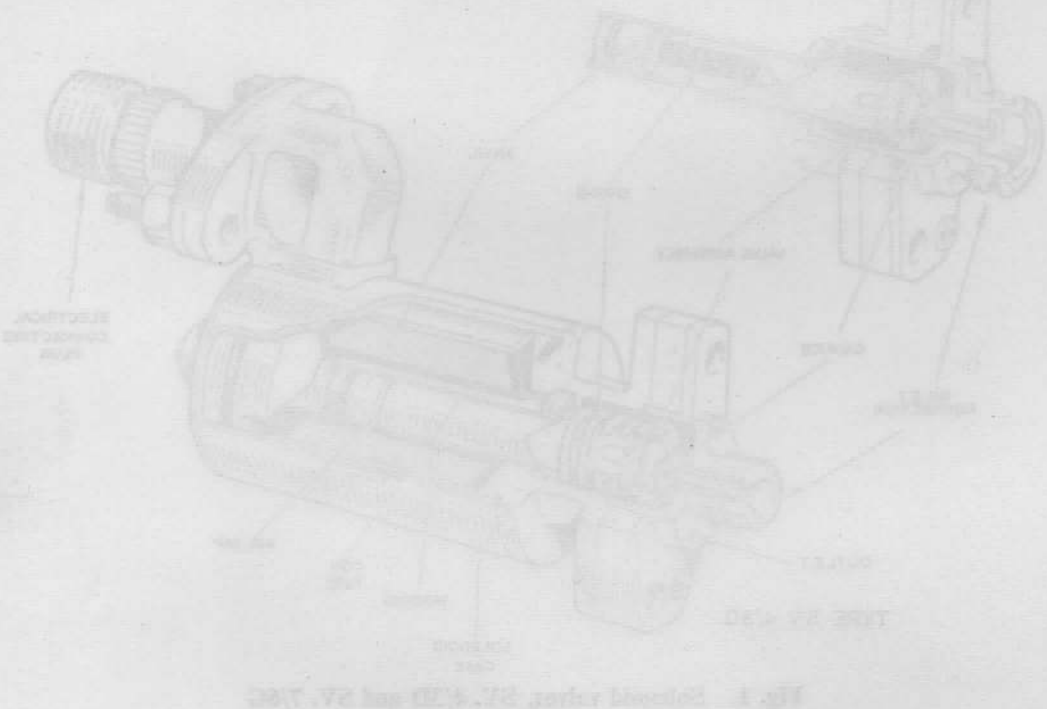

**RESTRICTED**

This file was downloaded  
from the RTFM Library.

Link: [www.scottbouch.com/rtfm](http://www.scottbouch.com/rtfm)

Please see site for usage terms,  
and more aircraft documents.

