

SECTION 12

ARMAMENT SERVICING EQUIPMENT

LIST OF ITEMS

	Now AP 110H-0001-1		
	Sect	Chap	Item
5 Winch, bomb, 1000 lb.	2	1	1
6 Winch, bomb, 4000 lb.	2	1	3
8 Trolley, bomb, Type F	1	1	2
▶ 11 Stand, gun harmonizing, universal	2	1	6
15 Rig, test, winch clutch, Mk 2	7	1	7
18 Trolleys, bomb loading, Canberra Mk 1 and Mk 2	1	1	10
20 Winch, bomb, 2000 lb.	2	1	2
23 Machine, belt filling, positioning and debelting, Aden, 30mm	8	1	1
29 Trolley, servicing, Hunter gun package	3	3	1
34 Hoist, bomb loading, Type C	2	1	4
35 Trolley, transporting, gun package	1	1	12
37 Sling, bomb, three-legged	2	3	2
38 Stand, servicing, for Mk 30 torpedo	4	2	4
▶ 39 Cradle, transporting and storage for 30mm Aden gun	1	2	4
44 Trolley, platform, aircraft servicing, G.P. (with canopy)			
	AP 119A-1000-1A		
	7	-	26
51 Stand, servicing, ejection seat	AP 110H-0001-1		
	8	1	1
55 Hoist, heavy aircraft components, 2½ cwt	AP 119A-1000-1E		
	2		15
61 Instrument, gun aligning (Lightning)	AP 110H-0001-1		
	3	2	4
62 Chamber, vacuum testing, Mk 2	5	1	4
65 Tester, for No. 3 Mk 3 E.M. release unit	7	1	6
67 Bomb loading equipment (Vulcan 7 - store carrier)	2	6	3
69 Trolleys, bomb, Type J, Mk 1 and 2	1	1	3
▶ 74 Trolley, servicing, bomb carrier, Type A	4	1	3

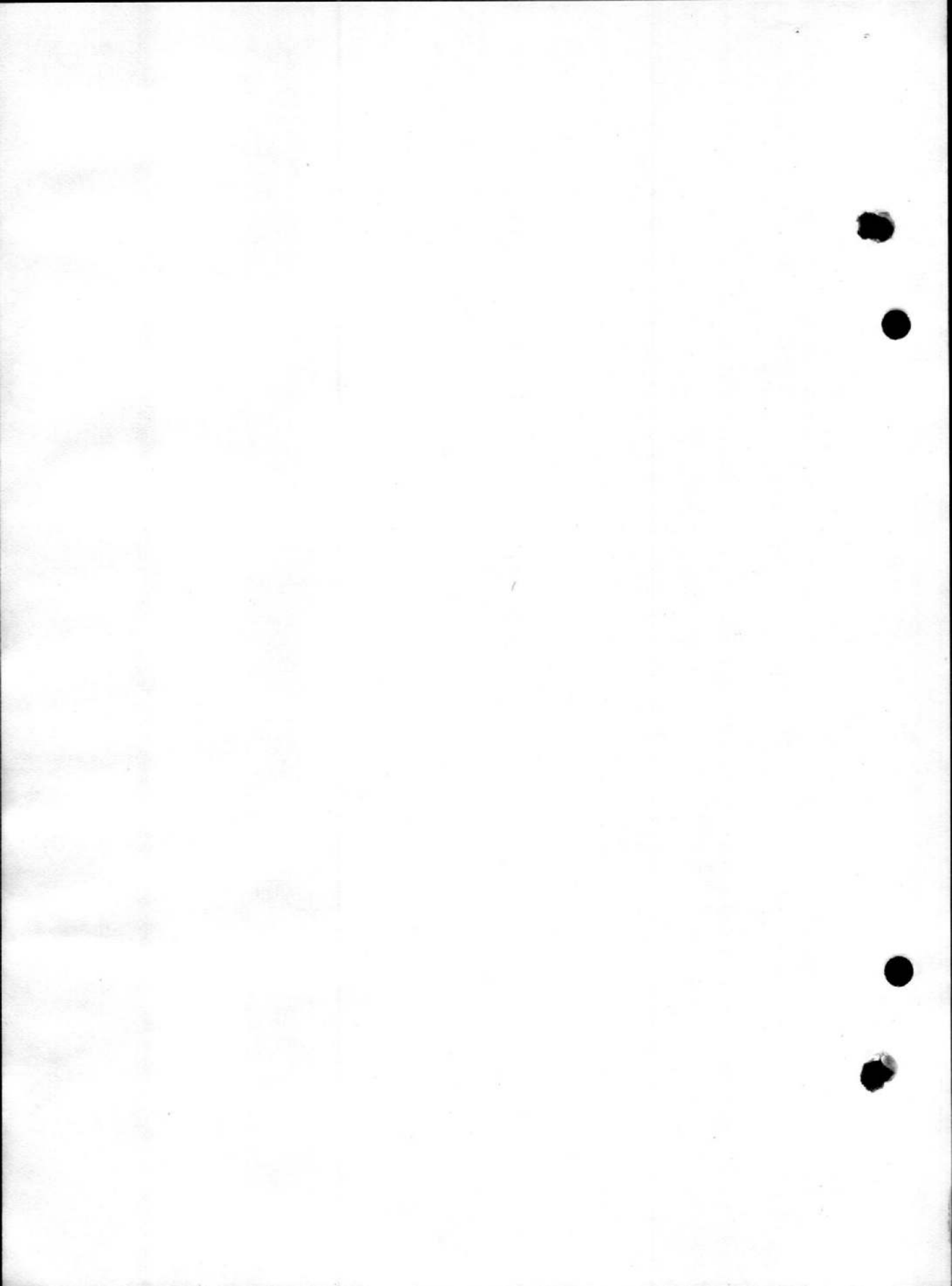

ITEM 1

TRANSPORTER, BOMB, AIRFIELD, STANDARD

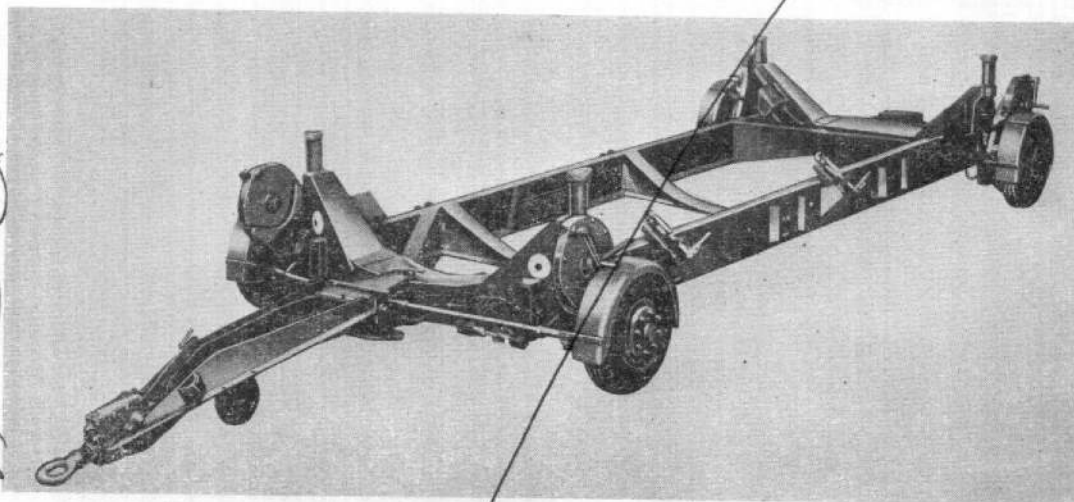

A.P.Reference 1664D (2nd Edn.), Vol. 1, Part 1, Sect. 1, Chap. 7

Stores Ref. 4G/4490

Classification I

Overall dimensions

Length 24 ft. 0½ in.

Width 7 ft. 11½ in.

Height 2 ft. 6 in.

Weight 3,115 lb.

Brief description This transporter is used to carry 1,000 lb. to 10,000 lb. bombs and 2,000 lb. mines between the storage dump and the aircraft in which they are to be loaded. It consists of a four-wheeled chassis on which detachable cradles are mounted for supporting the bombs or mines; the cradles are provided in various sizes to suit the store to be carried. Hydraulic jacks operated by a hand pump are fitted to the transporter to enable the chassis frame to be raised or lowered; the ground clearance of the frame when in the lowered position is ½ in., and 6½ in., when raised. The chassis is fitted with both front and rear steering; steering at the front is effected by the towbar, and at the rear by a detachable tiller bar. Hydraulic brakes are fitted to the four road wheels and can be operated either by a hand lever or by an overrun mechanism in the towbar. The maximum safe loading of the transporter is 14,000 lb.

ITEM 2

ROPE, WITH END FITTING

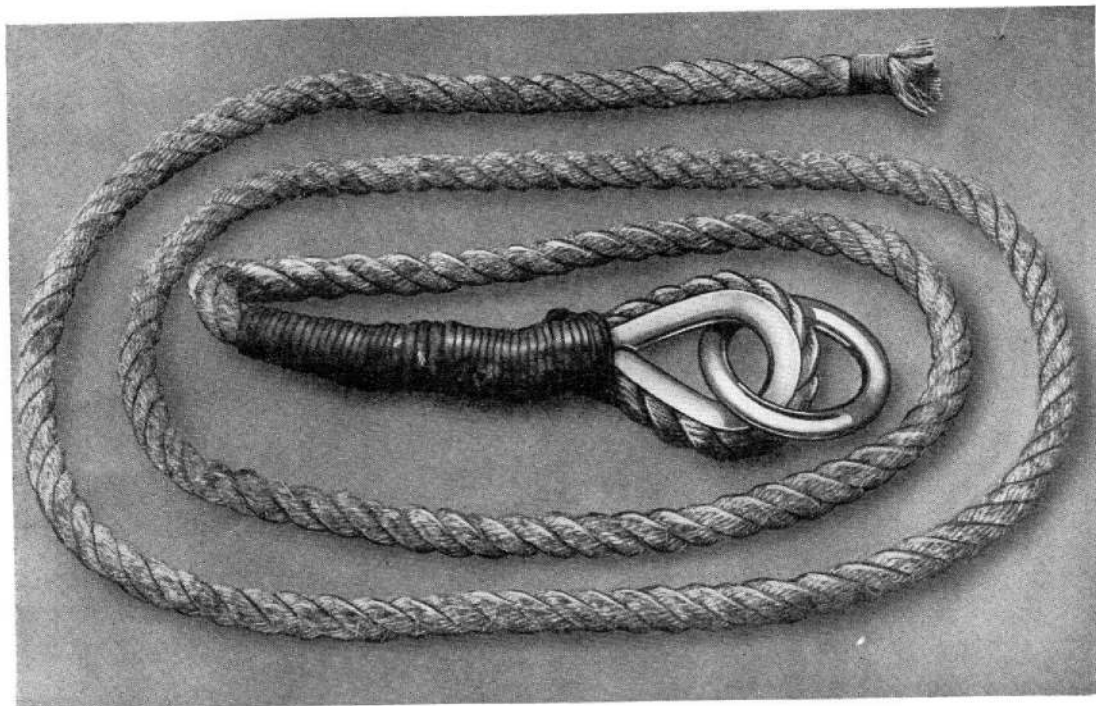

A.P. Reference

Stores Ref. 4G/2594

Classification 2

Overall dimensions

Length 12 ft.

Weight 4 lb.

Brief description This rope is used for loading bomb trolleys. The end fitting comprises an 8 in. dia. metal ring which is held by a spliced thimble-eye.

RESTRICTED

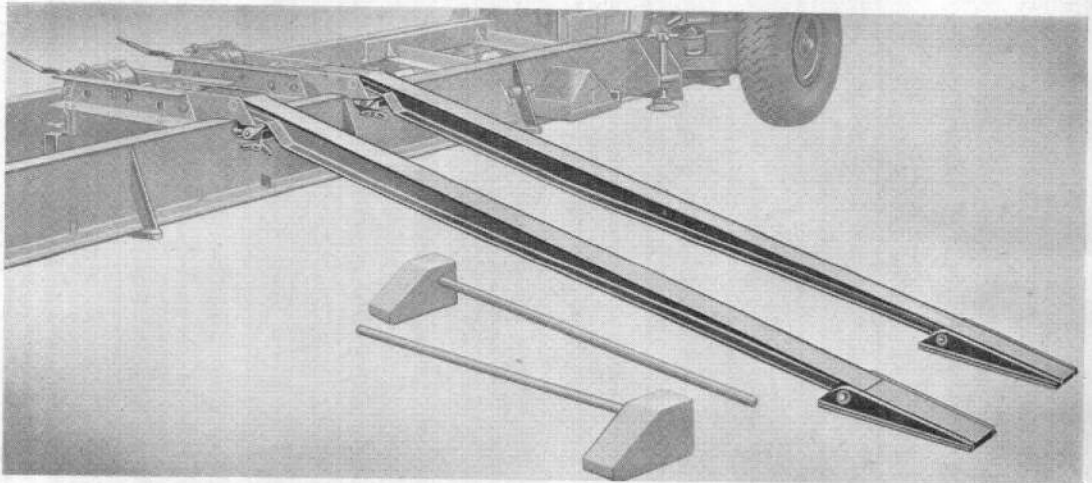
ITEM 3**MEMBERS, RAMP**

A.P. Reference 1664D (2nd Edn.), Vol. 1, Part 1, Sect. 2, Chap. 3

Ref. No. 4G/2548

Classification 3

Overall dimension (each ramp)

Length 10 ft. 9 in.

Width 4 in.

Height 7 in.

Weight 1 cwt. 2 qr. 7 lb.

Brief description These "H" section steel ramps are used to facilitate the loading and unloading of Type E bomb trolleys without the use of a crane or gantry. The upper end of each ramp is hinged to a clamp bracket on the trolley, and the lower end has a hinged foot which lies flat on the ground. Loads up to a maximum of 12,000 lb. in weight can be supported on two ramps.

RESTRICTED

ITEM 4

RIG, TEST, WINCH CLUTCH, Mk. 1

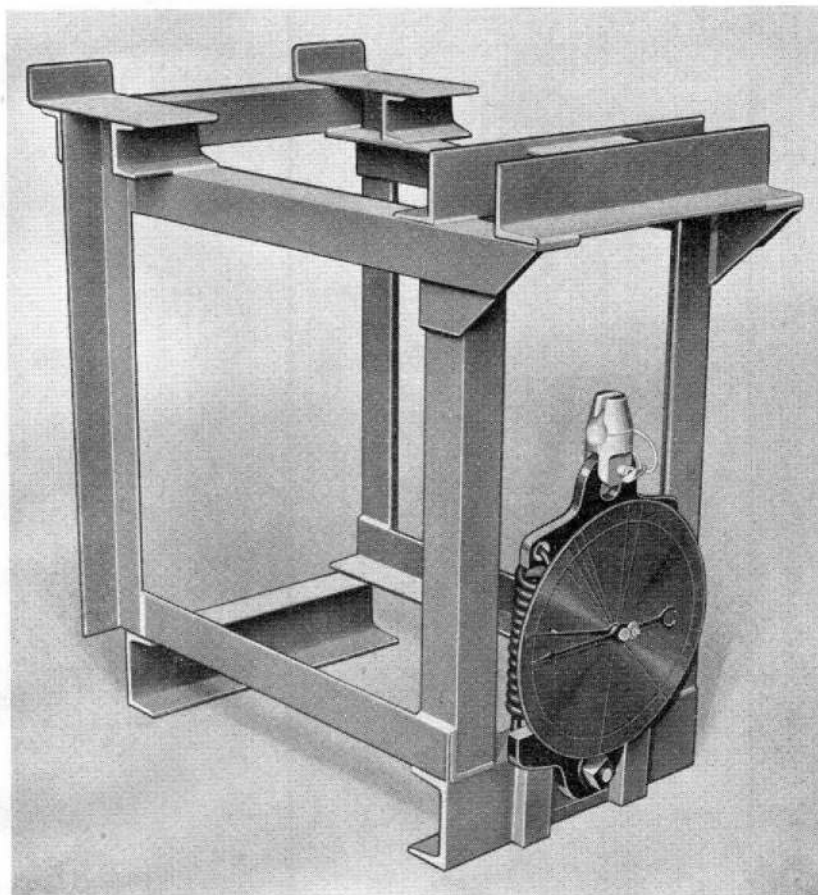

A.P. Reference 1664C, Vol. 1, Sect. 3, Chap. 2

Ref. No. 4G/3192

Classification 2

Overall dimensions

Length 2 ft. 8 in.

Width 1 ft. 11 in.

Height 2 ft. 8 in.

Weight 95 lb. approx.

Brief description This rig is used for testing and adjusting the setting of slipping clutches of the 500 lb., 1,000 lb. and the 2,000 lb. (Mk. 1 and 2) standard bomb winches. The rig comprises a rectangular stand of angle iron and channels welded together. At the front of the rig is mounted a spring balance or dynamometer, the dial of which is graduated in increments of 25 lb. from 0 to 4,500 lb.

RESTRICTED

ITEM 5

WINCH, BOMB, 1,000 lb.

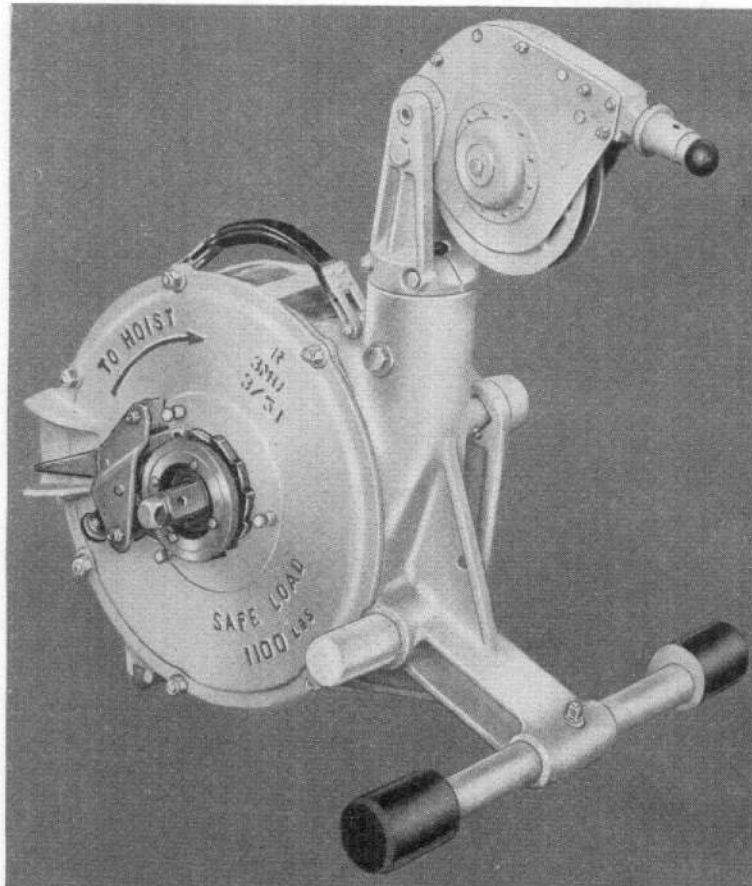

A.P. Reference 1664C, Vol. 1, Sect. 1, Chap. 3

Stores Ref. 4G/3246

Classification 2

Overall dimensions

Length 1 ft. 9 in.

Width 1 ft. 5 $\frac{1}{4}$ in.

Height 1 ft. 10 $\frac{1}{2}$ in.

Weight 65 lb.

Brief description This portable winch is designed for hoisting and lowering bombs and bomb carriers to and from aircraft bomb stations. The winch may be operated by hand or driven by an electrical or hydraulic drive unit. The winch consists of an enclosed cable drum and gearing, and external controls for hoisting or lowering and for the quick wind-in of slack cable.

ITEM 6

WINCH, BOMB, 4,000 lb.

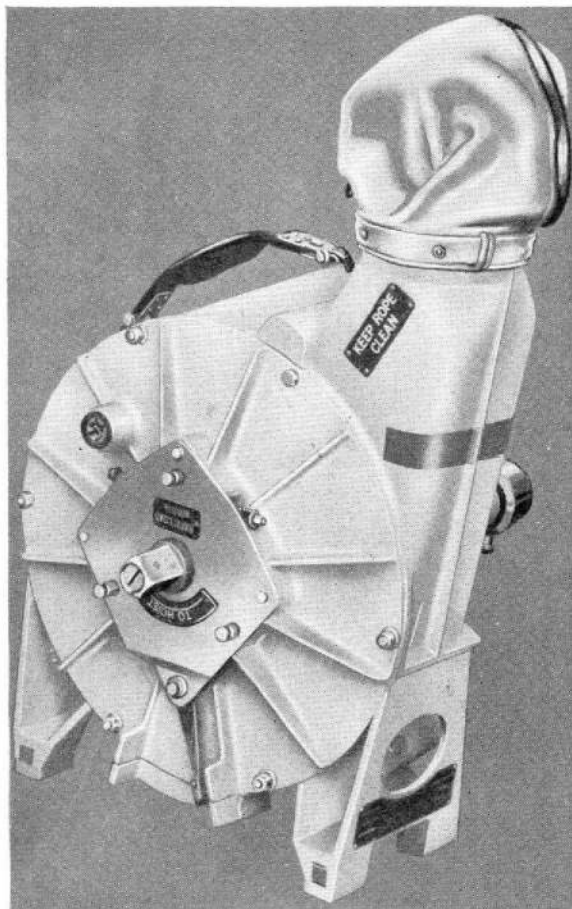

A.P. Reference 1664C, Vol. 1, Sect. 1, Chap. 5

Stores Ref. 4G/2348

Classification 2

Overall dimensions

Length 1 ft. 2 in.

Width (less handle) 10 in.

Height 1 ft. 8 in.

Weight 88 lb.

Brief description This portable winch is used in the fuselage bomb stations of aircraft. When in use, the winch locating piece is inserted into a socket at the appropriate bomb station of the aircraft; when not in use, the winch is inverted and rests on rubber feet. The winch casing encloses a cable drum, ratchet wheel, clutch, and brake. A carrying handle is fitted to the outside of the case, and a dust excluding canvas cover with a zip fastener is permanently attached. The equipment may be operated by hand or driven by an electric or hydraulic drive unit.

RESTRICTED

ITEM 7

TROLLEYS, BOMB, TYPES E and H

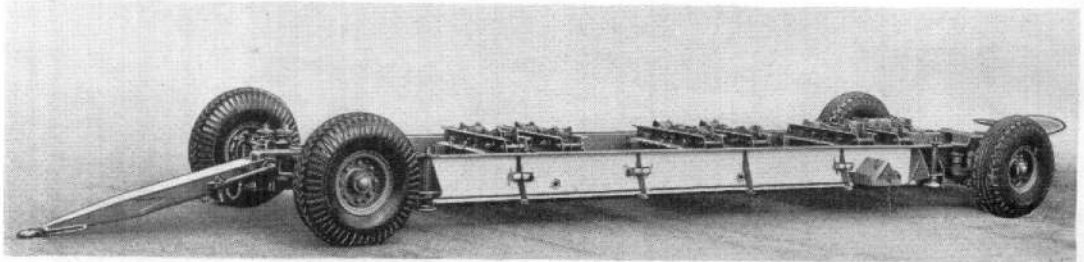

A.P. Reference 1664D (2nd Edn.), Vol. 1, Part 1, Sect. 1, Chap. 2 and 4

Stores Ref. 4G/2315, 3137

Classification 2

Overall dimensions

Length (less tow-bar) 24 ft. 11 $\frac{1}{4}$ in. **Width** 7 ft. 4 in. **Height** 2 ft. 10 in.

Weight 3 tons 17 cwt. (Type E), 4 tons (Type H)

Brief description The Type E bomb trolley is used to carry one large bomb or an alternative load of smaller bombs of a total weight not exceeding 22,000 lb. The trolley consists of a four-wheeled chassis fitted with tow-bar, screw-jacks, towing hook and traversing gear. At the rear end of the trolley is a seat for an operator to control the rear wheel steering and hydraulic brakes. The ground clearance when the trolley is loaded is 6 $\frac{1}{2}$ in., and the tow-bar length is 5 ft. 9 in. The Type H bomb trolley consists of a Type E trolley fitted with hoisting gear for raising either the 12,000 lb. or 22,000 lb. bomb into the bomb bay of an aircraft.

ITEM 8

TROLLEY, BOMB, TYPE F

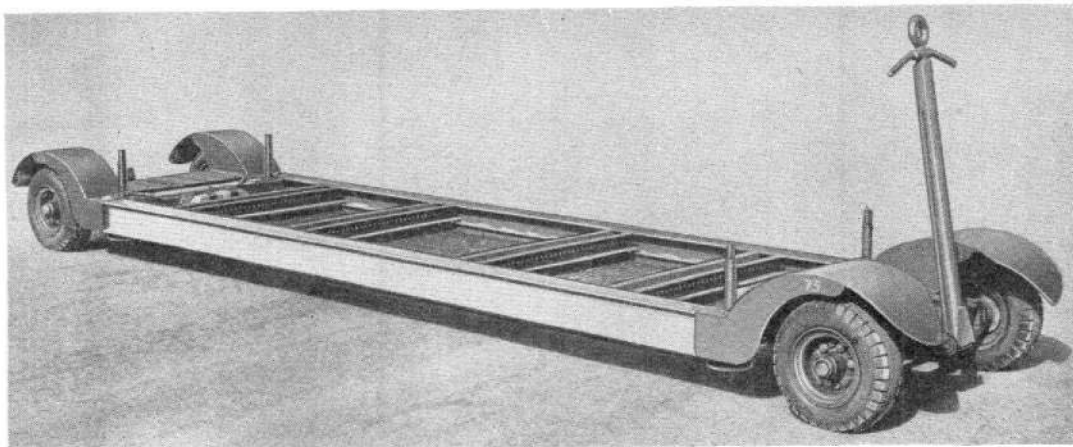

A.P. Reference 1664D (2nd Edn.), Vol. 1, Part 1, Sect. 1, Chap. 3

Stores Ref. 4G/2668

Classification 2

Overall dimensions

Length (less tow-bar) 16 ft. 5 in. **Width** 4 ft. 0 in. **Height** 1 ft. 8 in.

Weight 18 cwt.

Brief description This trolley is designed to carry bombs of varying types, the total weight of which must not exceed 8,000 lb. The chassis consists of two I-section steel side-members joined together at each end by box-section cross-members. A steel lattice floor is welded to the lower flanges of the side members. A built-in screw-jack is positioned at each of the four corners of the chassis. The length of the tow-bar is 3 ft. 10½ in.

RESTRICTED

ITEM 9

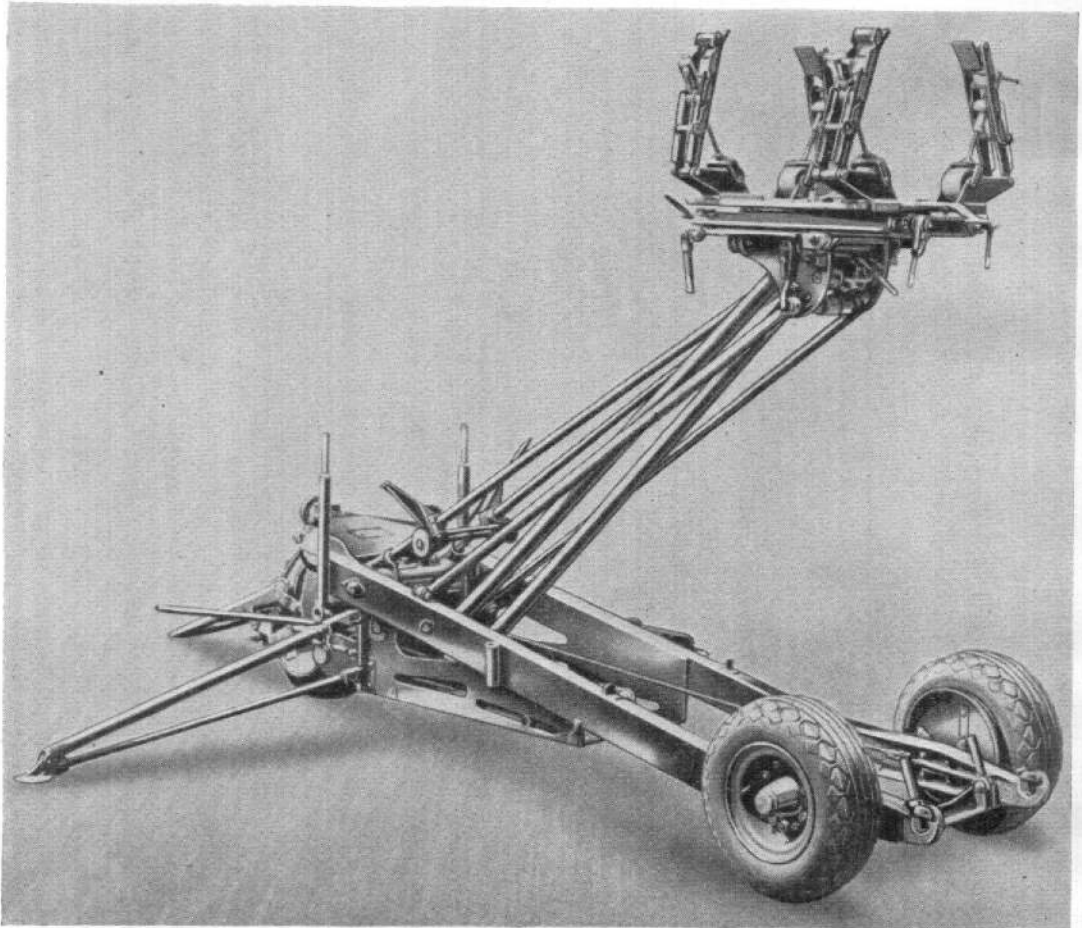
TROLLEY, BOMB, TORPEDO, Mk. I**A.P. Reference** 1664D (2nd Edn.), Vol. 1, Part 1, Sect. 1, Chap. 5**Stores Ref.** 4G/3925**Classification** I**Overall dimensions****Length** 9 ft. 6½ in.**Width** 2 ft. 11 in.**Height** 6 ft. 8 in.

(ram extended)

2 ft. 9½ in.

(ram retracted)

Weight 10 cwt. 1 qr. 21 lb.

Brief description This trolley is for Naval use only, and is designed to carry and to load into an aircraft a bomb, mine, or torpedo of between 10 in. and 24 in. in diameter, and not exceeding 2,000 lb. in weight. The trolley may be used also for transporting or supporting other equipment and can be towed at a maximum speed of 10 m.p.h. The load is supported on an adjustable elevating head which can be raised hydraulically to a maximum height of 6 ft. 8 in. by the operation of two hand pump levers. An outrigger is mounted on each side of the trolley frame to stabilise the trolley when raising or lowering a load. The illustration above shows the elevating head in the raised position.

ITEM 10

TROLLEY, LOW LOADER, FIGHTER

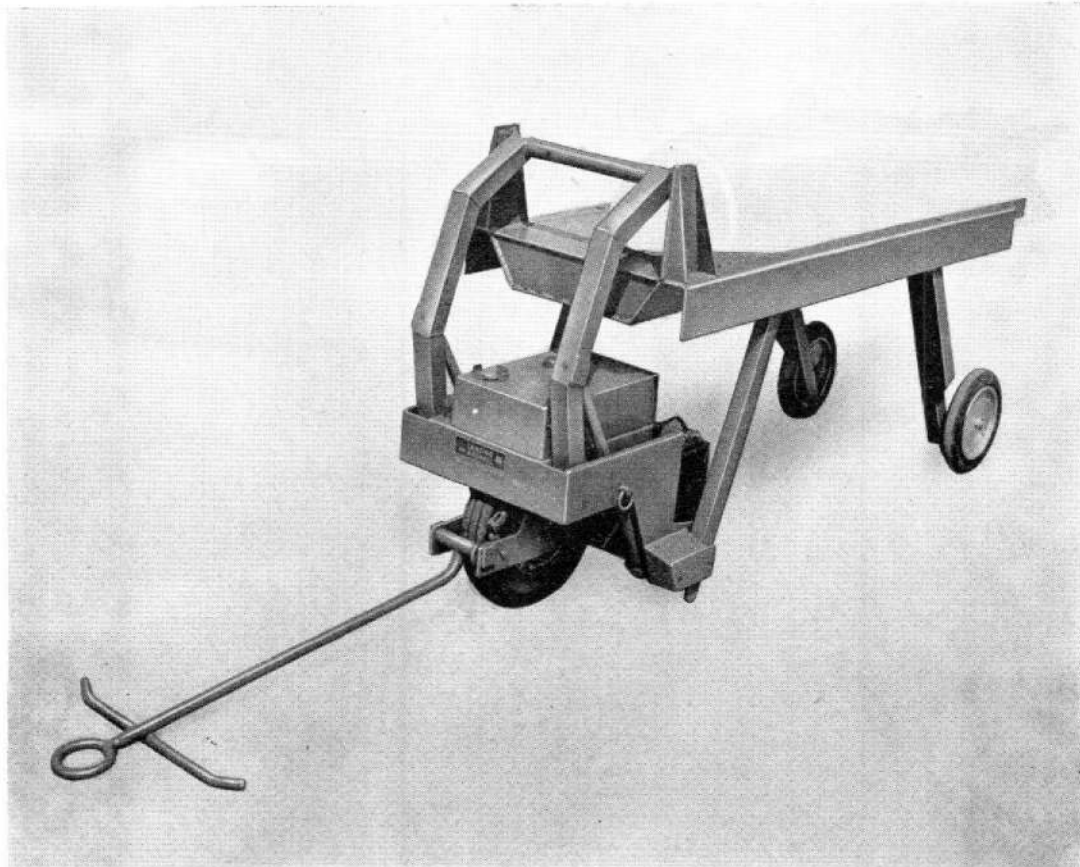

A.P. Reference 1664D (2nd Edn.), Vol. 1, Part 1, Sect. 2, Chap. 1

Stores Ref. 4G/4515

Classification 1

Overall dimensions

Length 7 ft. 3 in.
(fork raised)
9 ft. 5 in.
(fork lowered)

Width 2 ft. 1 in.

Height 3 ft. 5 in.
(fork raised)
1 ft. 10 in.
(fork lowered)

Weight 510 lb. (less battery)

Brief description This trolley is designed to raise a 1,000 lb. bomb from the ground to the height required for attaching the bomb to the carrier on a fighter aircraft. It is not intended to be used as a trolley for transporting the bomb, nor should it be towed other than by hand. The bomb is supported in a fork assembly which can be raised and lowered hydraulically by the operation of an electric motor-driven pump; a 12 volt battery provides the power for driving the motor. A hand-operated piston pump is incorporated in the hydraulic system for use in an emergency. The maximum safe load is 1,000 lb.

RESTRICTED

ITEM 11

STAND, GUN HARMONIZATION, UNIVERSAL

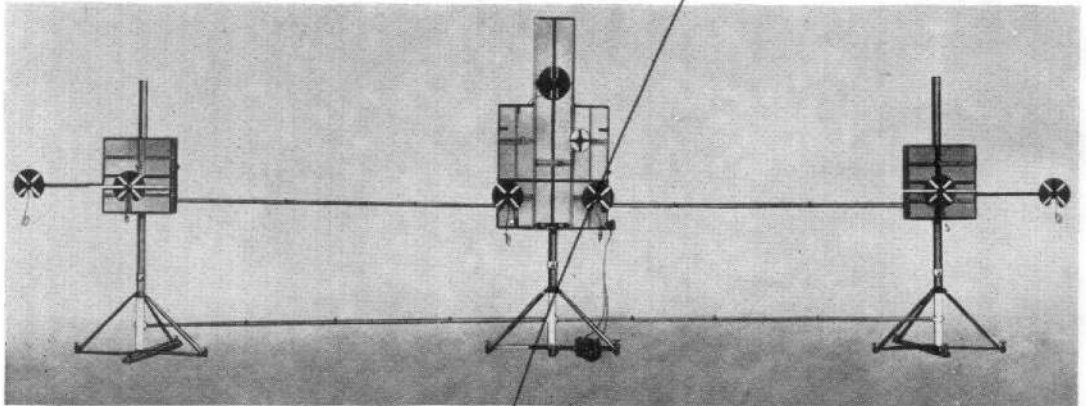

A.P. Reference 4483A, Vol. 1, Part 1, Sect. 1, Chap. 1

Stores Ref. 4G/3977

Classification I

Overall dimensions and weight (packed in transit cases)

	Length	Width	Height	Weight
4G/4788 Board assembly	4 ft. 0 in.	4 ft. 0 in.	9 in.	188 lb.
4G/4789 Board assembly	2 ft. 9 in.	2 ft. 7 in.	9 in.	131 lb.
4G/4790 Board assembly	2 ft. 9 in.	2 ft. 7 in.	9 in.	131 lb.

Brief description This universal stand is used for harmonizing the gunsight with the camera and the guns installed in aircraft. The stand consists of three board assemblies for centre, port wing and starboard wing; these assemblies are connected by tie-rods which can be adjusted in length between 3 ft. and 12 ft. Sighting discs for the gunsight, camera and guns can be mounted as required on the board assemblies; each board is provided with graduated slides and rails for adjusting the positions of the sighting discs. Three special-to-contents containers are provided for stowing the equipment.

AC76

ITEM 12

STAND, GUN HARMONIZING, TYPE B

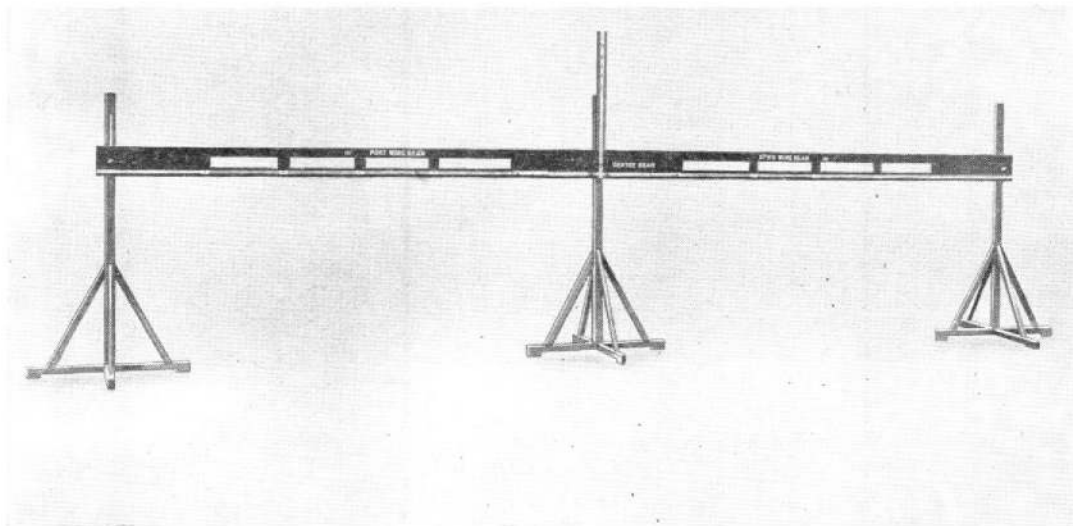

A.P. Reference

Stores Ref. 4G/3683

Classification 2

Overall dimensions (dismantled)

	Length	Width	Height
Uprights	8 ft. 3 in.	3 ft. 0 in.	4 ft. 9 in.
Beams	11 ft. 6 in.	10 in.	6 in.

Weight 1 cwt. 16 lb.

Brief description This stand is used in conjunction with sighting discs when harmonizing guns and ciné cameras in aircraft. The stand consists of three beam-supporting uprights and two beams which butt together to form one length. The height of the beam is adjustable.

~~RESTRICTED~~

ITEM 15

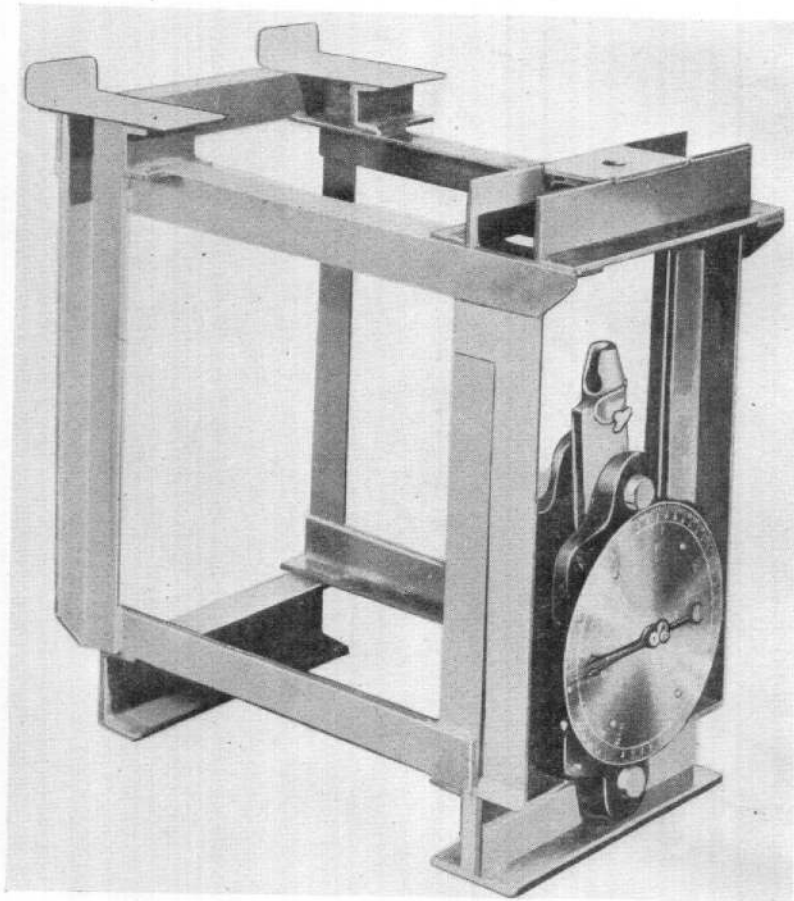
RIG, TEST, WINCH CLUTCH, Mk. 2**A.P. Reference** 4483A, Vol. I, Part I, Sect. 4, Chap. I**Stores Ref.** 4G/4420**Classification** I**Overall dimensions****Length** 2 ft. 3 in.**Width** 1 ft. 6 in.**Height** 2 ft. 4 in.**Weight** 167 lb.

Brief description This rig is used for testing and adjusting the slipping clutches of the 500 lb., 1,000 lb., 2,000 lb., 4,000 lb. and 6,000 lb. standard bomb winches, and the bomb loading hoist, Type C. The test rig consists of a welded steel stand on the front end of which two identical spring balances are bolted to the bottom cross-member. The dial of each spring balance is graduated in increments of 25 lb. from 0 to 4,500 lb., and is marked in sectors, one for each different winch clutch setting. The total load applied during tests is obtained, by adding together the maximum readings of the two spring balances.

ITEM 16

RAMP, LOADING, BOMB TROLLEY

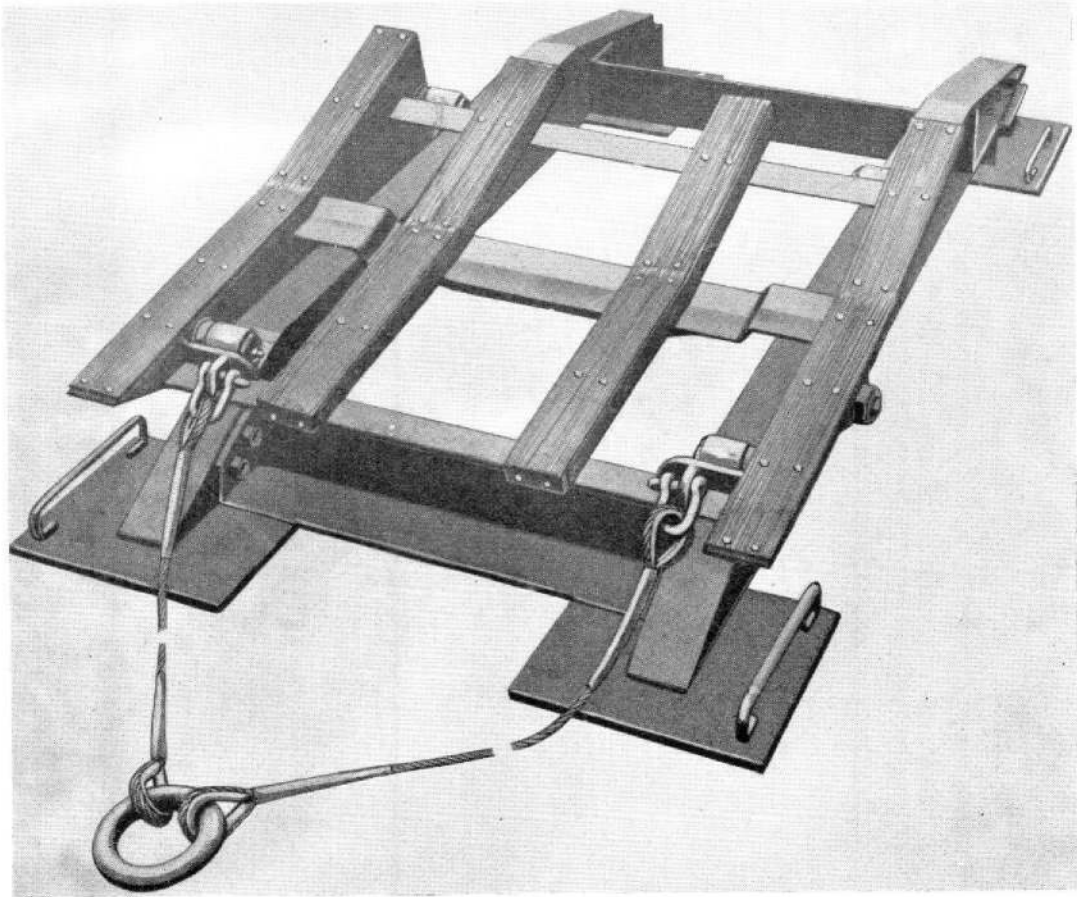

A.P. Reference 1664D (2nd Edn.), Vol. 1, Part 1, Sect. 2, Chap. 2

Stores Ref. 4G/2438

Classification I

Overall dimensions

Length 5 ft. 7 in.

Width 5 ft. 3 in.

Weight 3 cwt.

Brief description This ramp is used to facilitate the loading and unloading of Type C, Mk. 3, bomb trolleys without the use of a crane or gantry, and will support a load of up to 2,000 lb. The ramp consists of a ramp frame and a cradle. The frame rests on the ground and supports the cradle which carries the load. The cradle is mounted on rollers which run in guides along the frame. When the ramp is being used, the load is rolled on to the cradle which is then tilted on its centre rollers to align the top of the cradle with the frame, the cradle is moved along the frame towards the side of the trolley, and the load is then rolled off the cradle on to the trolley.

RESTRICTED

ITEM 17

PLATFORM, ASSEMBLY, FOR SECTIONAL BOMBS

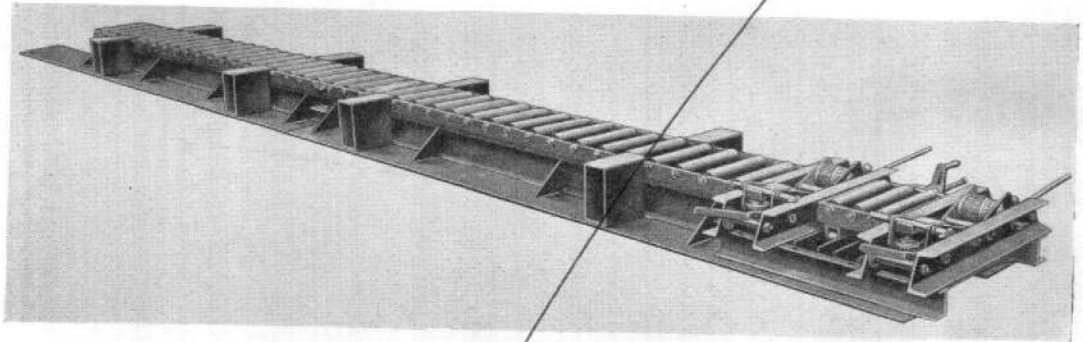

Handwritten signature or initials, possibly 'R 6-76'.

A.P. Reference 1664D (2nd Edn.), Vol. 1, Part 1, Sect. 2, Chap. 4

Stores Ref. 4G/3031

Classification I

Overall dimensions (assembled)

Length 25 ft. 8 in.

Width 2 ft. 11 in.

Height 10½ in.

Weight

Brief description This platform is used alongside a rolling bay for assembling sectional bombs and is supplied in two sections for ease of transportation. The main components of the platform are two roller conveyor sections, eight removable tables, a rising and falling gravity section, and two bearers. The removable tables are located four on each side of the conveyor sections; chocks are placed on the tables to prevent a bomb from rolling off the platform. The bearers are mounted with the gravity section at one end of the platform and are fitted with jack- and ratchet-operated roller chocks for raising or lowering and turning a bomb section when aligning the studs and stud holes prior to bolting two bomb sections together; the gravity section being lowered to allow the bomb section to rest on the rollers in the bearer chocks.

ITEM 18

TROLLEYS, BOMB LOADING, CANBERRA, Mk. 1 and Mk. 2

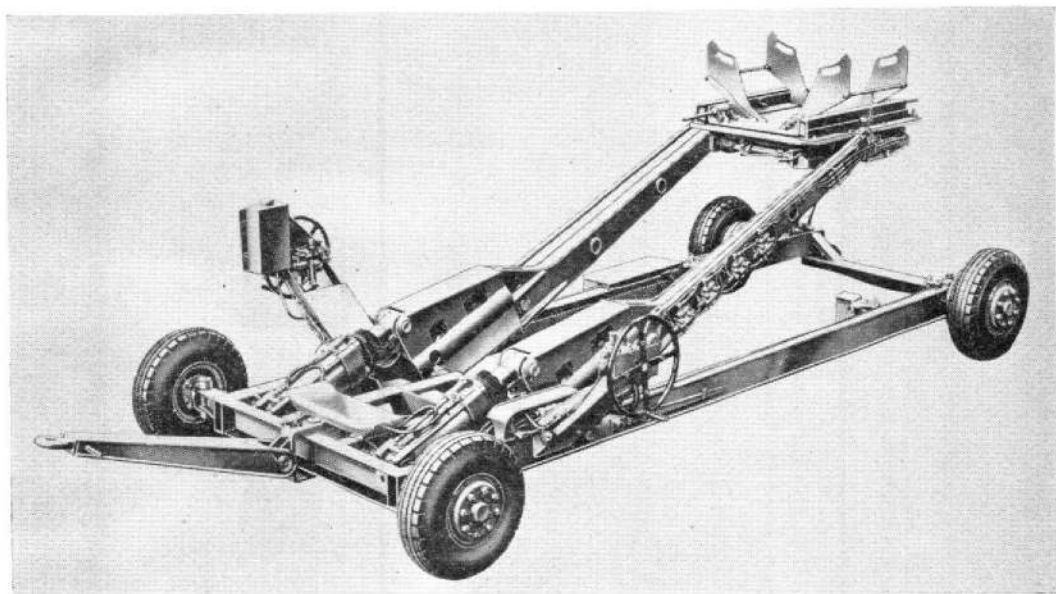

A.P. Reference 1664D (2nd Edn.), Vol. 1, Part 1, Sect. 2, Chap. 5

Stores Ref. 26FZ/95069 (Mk. 1 trolley)
26FZ/95111 (Mk. 2 trolley)

Classification I

Overall dimensions

Length (tow-bar raised) 17 ft. 10 in.

Width 6 ft. 11 in.

Height 3 ft. 4 in.

Weight 1 ton 9 cwt. 3 qr. 8 lb.

Brief description These trolleys are used for carrying bombs ranging from 16½ in. to 32 in. in dia., and for elevating these bombs into Canberra aircraft. The two marks of trolley are the same in construction, except for a difference in the design of the bomb cradle and its method of attachment at the elevating head, and the provision on the Mk. 2 trolley for coupling the hydraulic fluid supply line to the hydraulic pump on a motorised power truck. The load is supported on the elevating head which can be raised and lowered hydraulically from a minimum height of 7½ in. to a maximum height of 4 ft. 8 in. The maximum towing speed for each trolley is 20 m.p.h. and the maximum safe working load is 5,000 lb.

RESTRICTED

ITEM 19

PACK, POWER, FOR CANBERRA BOMB LOADING TROLLEY

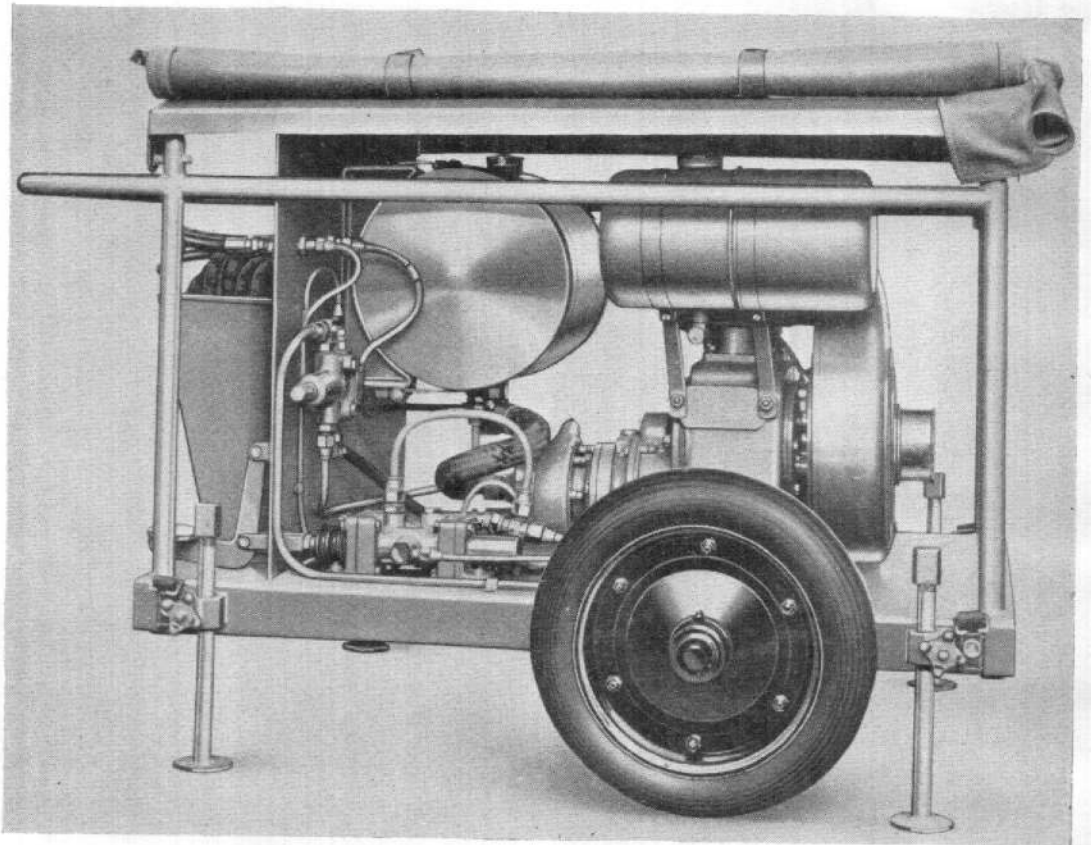

A.P. Reference 1664D (2nd Edn.), Vol. 1, Part 1, Sect. 2, Chap. 5, App. 1

Stores Ref. 26FZ/95263

Classification I

Overall dimensions

Length 3 ft. 9 in.

Width 2 ft. 9 in.

Height 2 ft. 6 in.

Weight 295 lb.

Brief description This power pack is used to apply hydraulic pressure for operating the elevating mechanism on the Canberra bomb loading trolley, Mk. 2. It consists of a Villiers Mk. 25 gasoline engine directly coupled to a hydraulic pump, a three gallon hydraulic fluid reservoir, and two 20 ft. hoses for connecting the power pack to the bomb loading trolley. This equipment, together with the necessary pipelines and operating valves, is mounted on a platform chassis fitted with two cushioned-tyred wheels and four adjustable drop legs. A tubular steel frame supports a sheet-metal top cover and canvas side curtains, and serves also as a handle for moving the power pack.

ITEM 20

WINCH, BOMB, 2,000 lb.

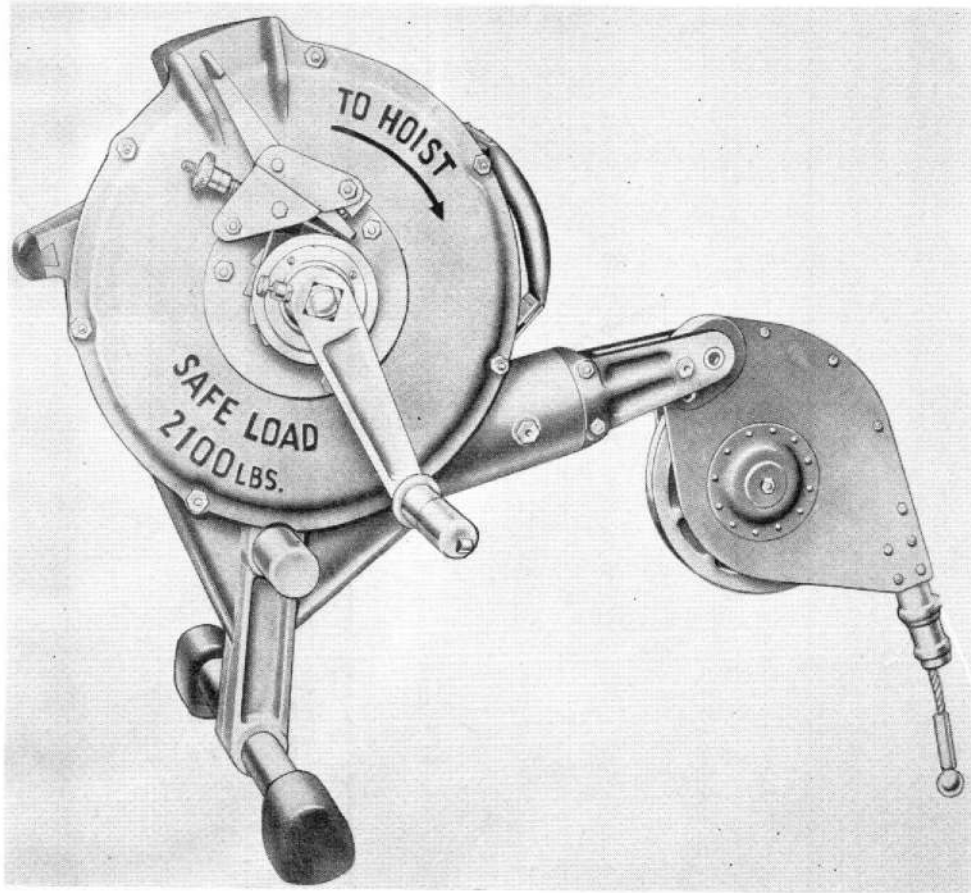

A.P. Reference 1664C, Vol. 1, Sect. 1, Chap. 4

Stores Ref. 4G/2331

Classification I

Overall dimensions

Length 2 ft. 9 in.

Width 1 ft. 5 in.

Height 1 ft. 10 in.

Weight 58 lb.

Brief description This portable winch is used for hoisting and lowering bombs and bomb carriers to and from aircraft bomb stations. The winch may be operated by hand or driven by an electrical or hydraulic drive unit. The winch consists of an enclosed cable drum, gearing, and slipping clutch, and external controls for hoisting or lowering and for the quick wind-in of slack cable. The clutch is set to slip when there is a load of 3,360 lb. on the cable. The total lift is 12 ft. 6 in.

RESTRICTED

ITEM 21

MACHINE, BELT POSITIONING, HISPANO, 20 mm., No. 2

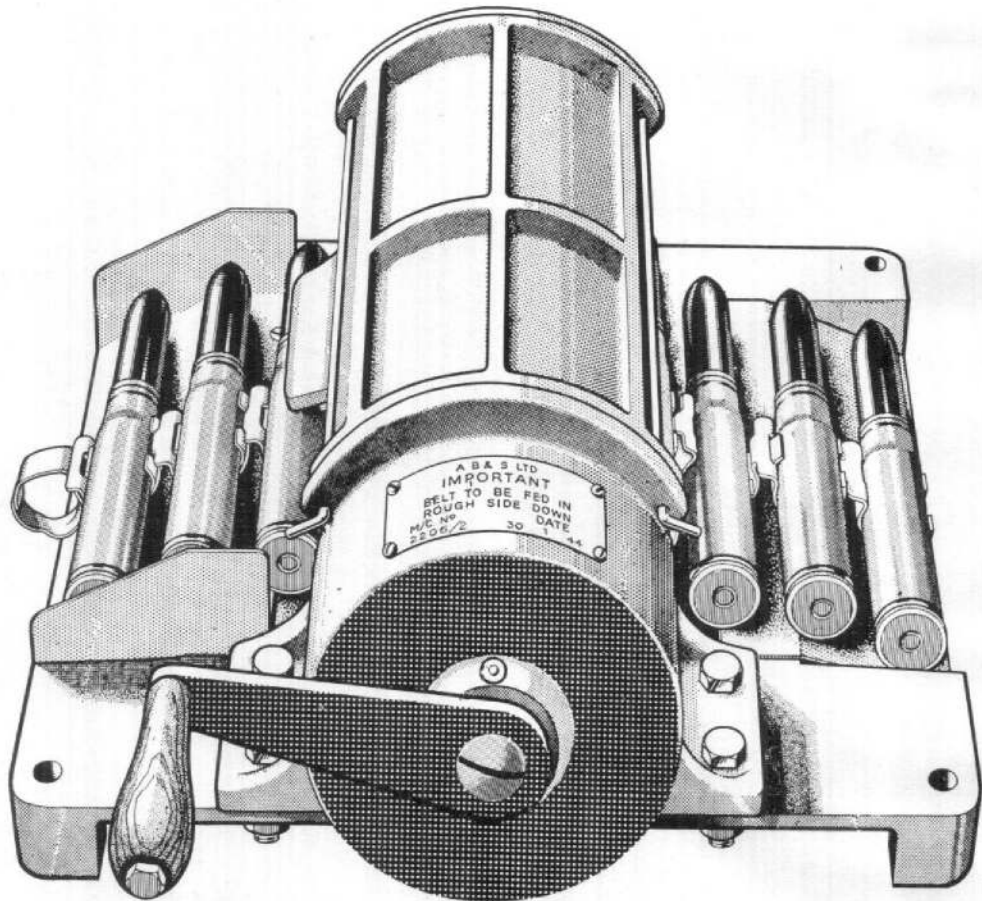

A.P. Reference 1641G (2nd Edn.), Vol. 1, Parts 1 and 3, Sect. 1, Chap. 2

Stores Ref. 8C/2296

Classification I

Overall dimensions

Length 1 ft. 2 in.

Width 1 ft. 0 in.

Height 6 in.

Weight 33 lb.

Brief description This machine is hand-operated and is designed to position 20 mm. Hispano ammunition in belt links. It consists of a base on which a driving shaft is mounted in two end bearings; a tappet block and three sprockets are fitted to the shaft which is rotated by a handle, and a nose adjusting cam is fitted at the front face of the rear bearing housing. Seven spring-loaded tappets are arranged cylindrically in the tappet block and parallel to the shaft, and move rearwards successively as the shaft is rotated. The belt is led into the machine from the left-hand side and the rotating sprockets engage the cartridges and feed the belt through the machine when the handle is turned. The relative position of the round in the link is determined by the setting of the sprockets and the nose adjusting cam and by the operation of the tappets.

ITEM 22

MACHINE, DEBELTING, HISPANO M.G., 20 mm.

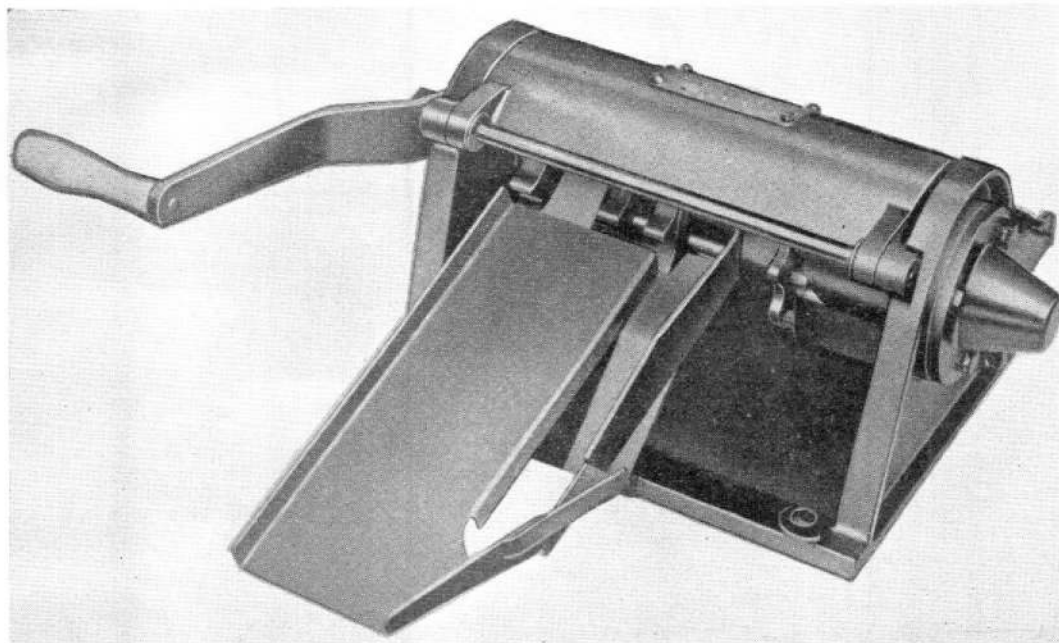

A.P. Reference 1641G (2nd Edn.), Vol. 1, Parts 1 and 3, Sect. 1, Chap. 3

Stores Ref. 8C/2362

Classification 1

Overall dimensions

Length 1 ft. 10 in.

Width 1 ft. 5 in.

Height 8 in.

Weight 56 lb.

Brief description This hand-operated machine is used for the speedy debelting of Hispano 20 mm. ammunition. It consists of a base casting in which a driving shaft is mounted in two end bearings. The debelting mechanism consists of two cams integral with the bearing housings, three feed sprockets keyed on the shaft, nine claw-type extractor rods which fit laterally in holes through the sprockets, exit and entry chutes, a hinged cover, and an operating handle. The extractor rods operate between the cams and, as the belt is fed through the machine by the rotating sprockets, the claws on the extractor rods engage in the extractor grooves on the cartridge cases and withdraw the cartridges from the belt links. The links then fall away into a container and the cartridges slide down the exit chute.

RESTRICTED

ITEM 23

**MACHINE, BELT FILLING, POSITIONING AND DEBELTING,
ADEN, 30 mm.**

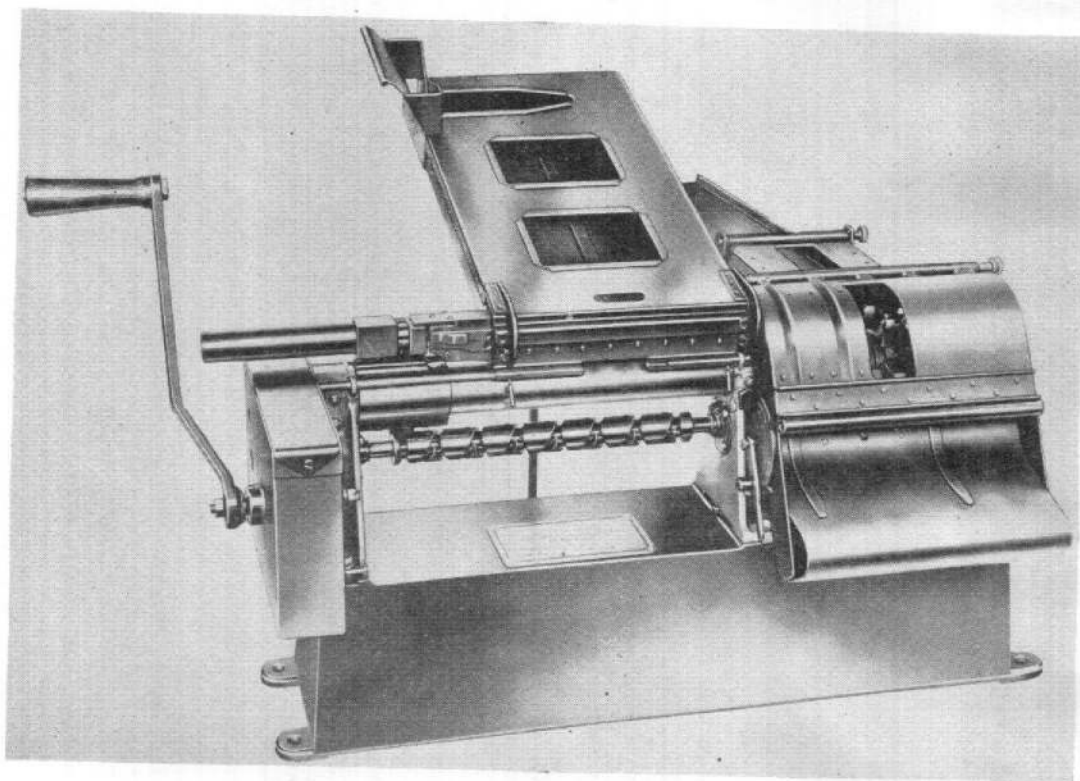

A.P. Reference 1641G (2nd Edn.), Vol. 1, Parts 1 and 3, Sect. 1, Chap. 4

Stores Ref. 8C/2373

Classification I

Overall dimensions

Length 2 ft. 5 in.

Width 1 ft. 4 in.

Height 1 ft. 3 in.

Weight 103 lb.

Brief description This hand-operated machine can be adapted, by the interchange of various components and the adjustment of the mechanism, for belt filling, belt positioning or debelting of Aden 30 mm. ammunition. The machine consists of a cast base on which three bearing housings carry the actuating shaft and sprocket shaft, and provide the mounting for the gearing and operating mechanism. Various types of chutes are provided to cover the three belting operations.

ITEM 24

MACHINES, BELT FILLING, BROWNING .50 in. AND HISPANO 20 mm.

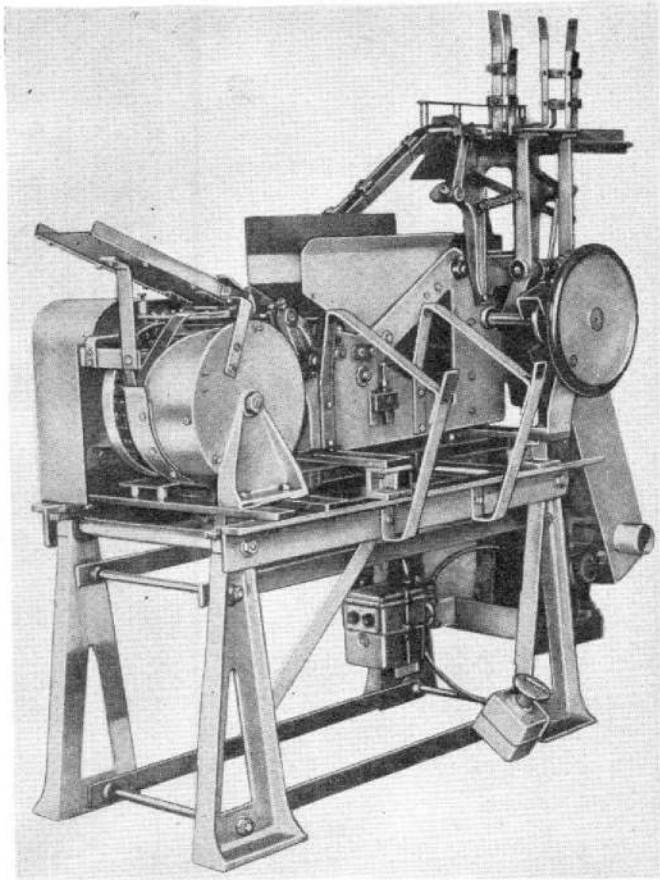

A.P. Reference 1641G (2nd Edn.), Vol. 1, Parts 1 and 3, Sect. 2, Chap. 1

Stores Ref. 8C/2235, 2239

Classification I

Overall dimensions

Length 6 ft. 2 in.

Width 2 ft. 6 in.

Height 4 ft. 3 in.

Weight 759 lb. (8C/2235) — 793 lb. (9C/2239)

Brief description These belt filling machines for Browning .50 in. and Hispano 20 mm. ammunition are of similar construction and differ only in the sizes of certain components such as link chutes, hopper, belt drum, etc., to accommodate the two different sizes of rounds and links. Each machine is driven by a 230 volts, $\frac{1}{3}$ h.p. electric motor controlled by a foot-operated switch; in an emergency the machine can be operated by turning a hand wheel. The belt filling mechanism is mounted on a four-legged stand, and the drive is fitted with a slipping clutch which automatically disengages the drive sprockets if an overload occurs during the operation of the machine.

~~RESTRICTED~~

ITEM 25

MACHINE, BELT POSITIONING, BROWNING ·50 in., Mk. 2

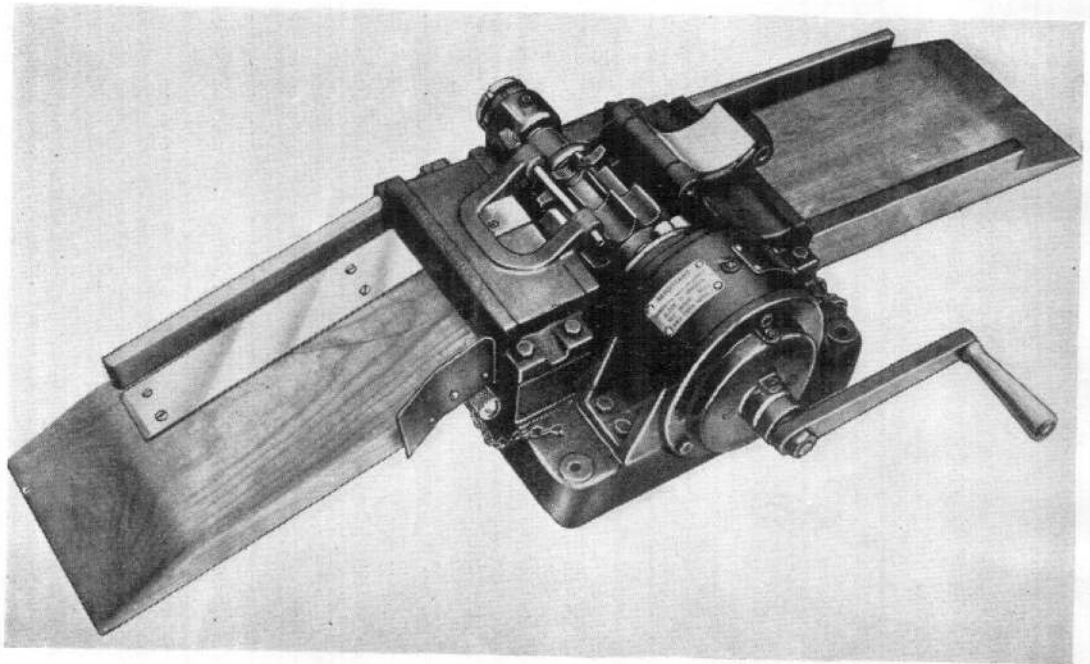

A.P. Reference 1641G (2nd Edn.), Vol. 1, Parts 1 and 3, Sect. 2, Chap. 2

Stores Ref. 8C/2315

Classification I

Overall dimensions

Length 1 ft. 11 in.

Width 1 ft. 3 in.

Height 8 in.

Weight 86 lb.

Brief description This Mk. 2 machine is hand-operated and is used to push Browning .50 in. ammunition to the correct position in the belt links into which the cartridges have been partly inserted; it will not withdraw them if they have been inserted too far. The machine consists of a cast base on which two end bearings support a gear and drive shaft assembly, wooden feed outlet boards, a cam plate and an operating handle. Spring-loaded tappets mounted in the drive shaft are actuated by the cam when the handle is turned and push the cartridges into position as the belt is positioned and fed through the machine by the rotating gear assembly.

ITEM 26

MACHINE, DEBELTING, BROWNING, .50 in.

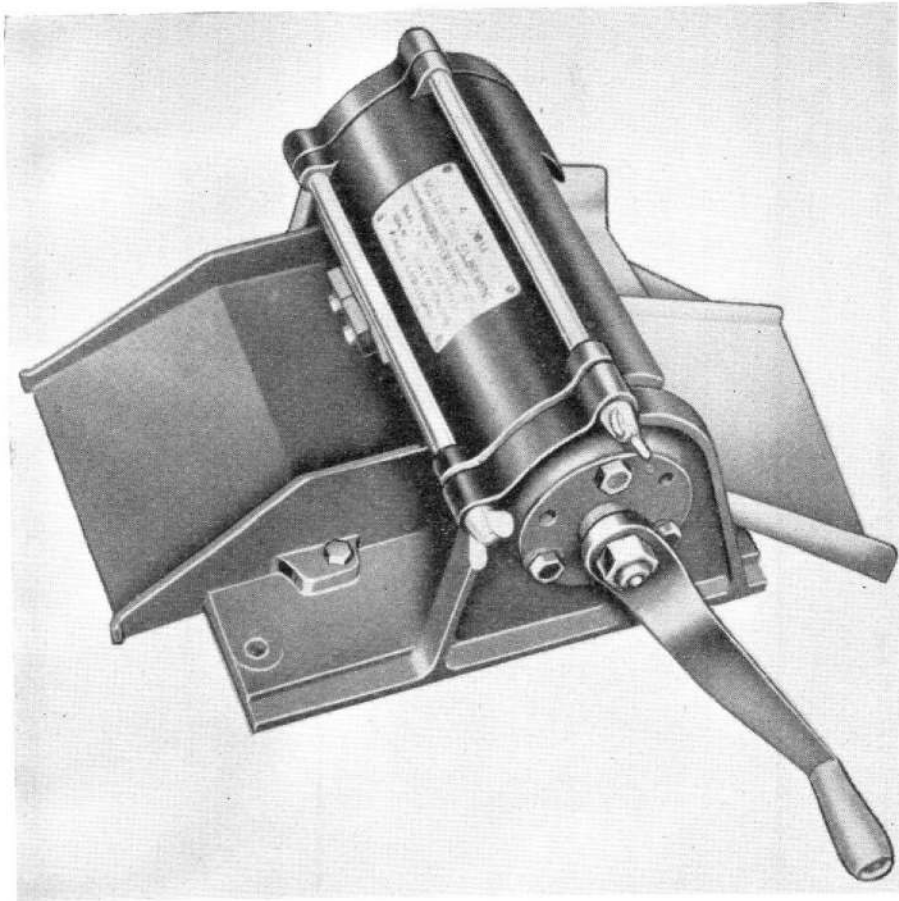

A.P. Reference 1641G (2nd Edn.), Vol. 1, Parts 1 and 3, Sect. 2, Chap. 3

Stores Ref. 8C/2318

Classification I

Overall dimensions

Length 1 ft. 3 in.

Width 1 ft. 2 in.

Height 7 in.

Weight 34 lb.

Brief description This hand-operated machine is used for the speedy debelting of Browning .50 in. ammunition. It consists of a base casting on which a driving shaft is mounted in two end bearings. The debelting mechanism consists of two cams integral with the bearing housings, a feed sprocket assembly keyed on the shaft, nine claw-type extractor rods which fit laterally in holes through the sprocket, exit and entry chutes, a hinged cover, and an operating handle. The extractor rods operate between the cams and, as the belt is fed through the machine by the rotating sprocket, the claws on the extractor rods engage in the extractor grooves on the cartridge cases and withdraw the cartridges from the belt links. The links and the cartridges then slide separately down the exit chute into containers.

RESTRICTED

ITEM 27

MACHINE, BELT FILLING, BROWNING .303 in.

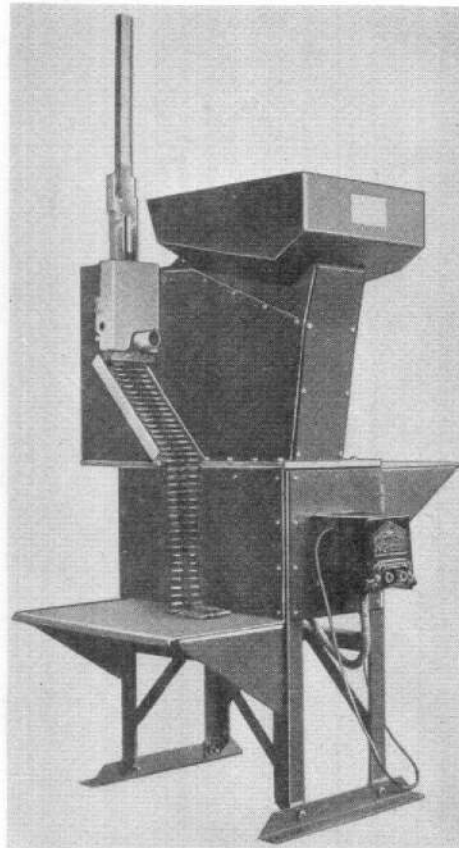

A.P. Reference 1641G (2nd Edn.), Vol. 1, Parts 1 and 3, Sect. 2, Chap. 4

Stores Ref. 8C/1664

Classification I

Overall dimensions

Length 2 ft. 8 in.

Width 2 ft. 1 in.

Height 3 ft. 8 in.

Weight 224 lb.

Brief description This filling machine for .303 in. Browning belts is driven by an electric motor and can, in an emergency, be driven by an operating handle. The machine automatically assembles cartridge belts from .303 in. S.A.A. cartridges placed at random in an open hopper, and a supply of links initially assembled in a container and then fed down a link chute. The rate of assembly is approximately 100 cartridges per minute. The machine mechanism is enclosed by detachable covers and guards, and a shelf is provided on each side of the machine to facilitate the handling of ammunition. The electric motor may be either of a.c. or d.c. type for use with 100/125 or 200/250 volts supply.

ITEM 28

MACHINE, BELT POSITIONING, BROWNING ·303 in., Mk. 2

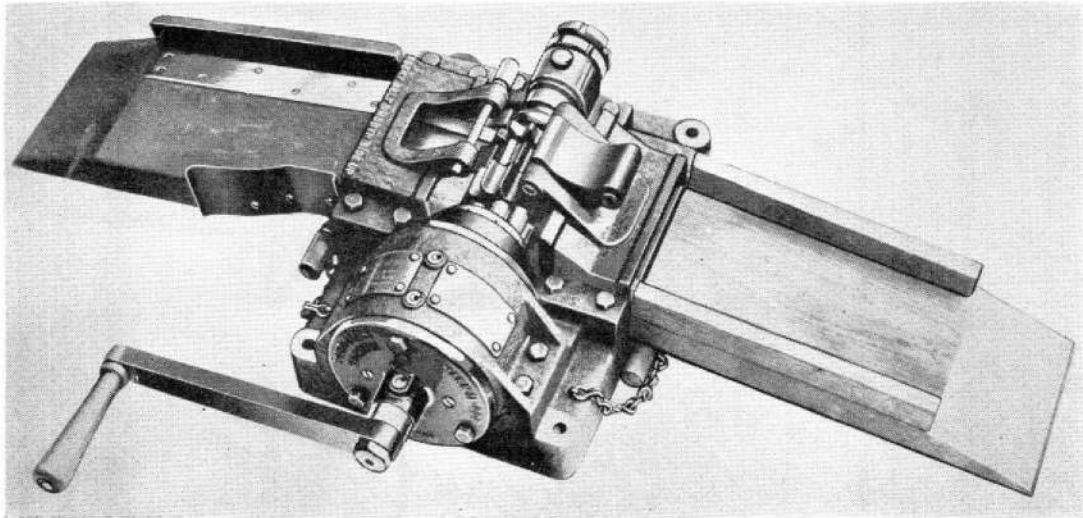

A.P. Reference 1641G (2nd Edn.), Vol. 1, Parts 1 and 3, Sect. 2, Chap. 6

Stores Ref. 8C/2314

Classification I

Overall dimensions

Length 1 ft. 5 in.

Width 11 in.

Height 6 in.

Weight 42 lb.

Brief description This Mk. 2 machine is hand-operated and is used to push Browning ·303 in. ammunition to the correct position in the belt links, into which the cartridges have been partly inserted; it will not withdraw them if they have been inserted too far. The machine consists of a cast base on which two end bearings support a gear and driving shaft assembly, wooden feed and outlet boards, a cam, and an operating handle. Ten spring-loaded tappets mounted in the driving shaft bear against the cam, and, when the handle is turned, the tappets are actuated and push the cartridges into position as the belt is positioned and fed through the machine by the rotating gear assembly.

RESTRICTED

ITEM 29

TROLLEY, SERVICING, HUNTER GUN PACKAGE

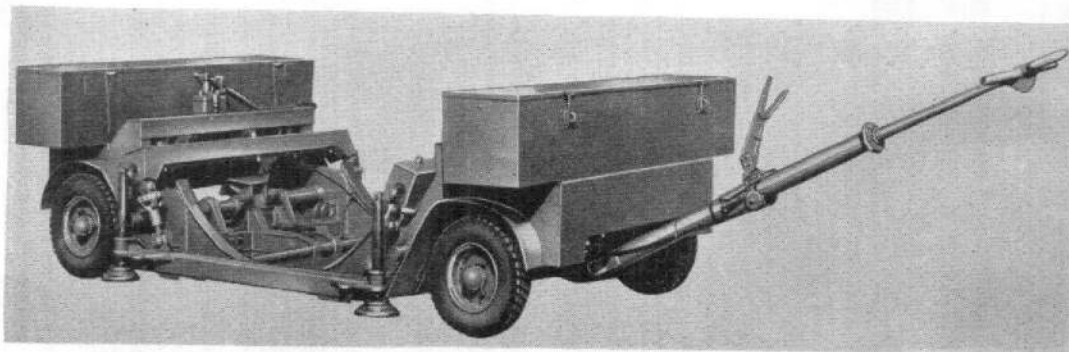

A.P. Reference 4483A, Vol. 1, Part 1, Sect. 1, Chap. 9

Stores Ref. 26FX/95038

Classification I

Overall dimensions

Length (with tow bar) 14 ft. 9 in. **Width** 5 ft. 3½ in. **Height** 2 ft. 9 in.

Weight 13½ cwt.

Brief description This trolley is used for transporting and servicing the Hunter gun package and also as a mounting from which guns installed in the gun package can be tested by firing. The trolley consists of a four-wheeled chassis fitted with a tow bar, towing eye and front wheel brakes. The chassis frame is shaped to form a cradle for the gun package and can be elevated by a hand-operated hydraulic pump; the hydraulic lift is 6 inches. Two stowage boxes are mounted on the chassis, one at each end, and four screw jacks are fitted at the base of the chassis for supporting the trolley with its wheels clear of the ground when the guns are test fired. The maximum safe load of the trolley is 2,000 lb.

ITEM 30

SLING, BOMB, CHAIN, FOUR-LEGGED

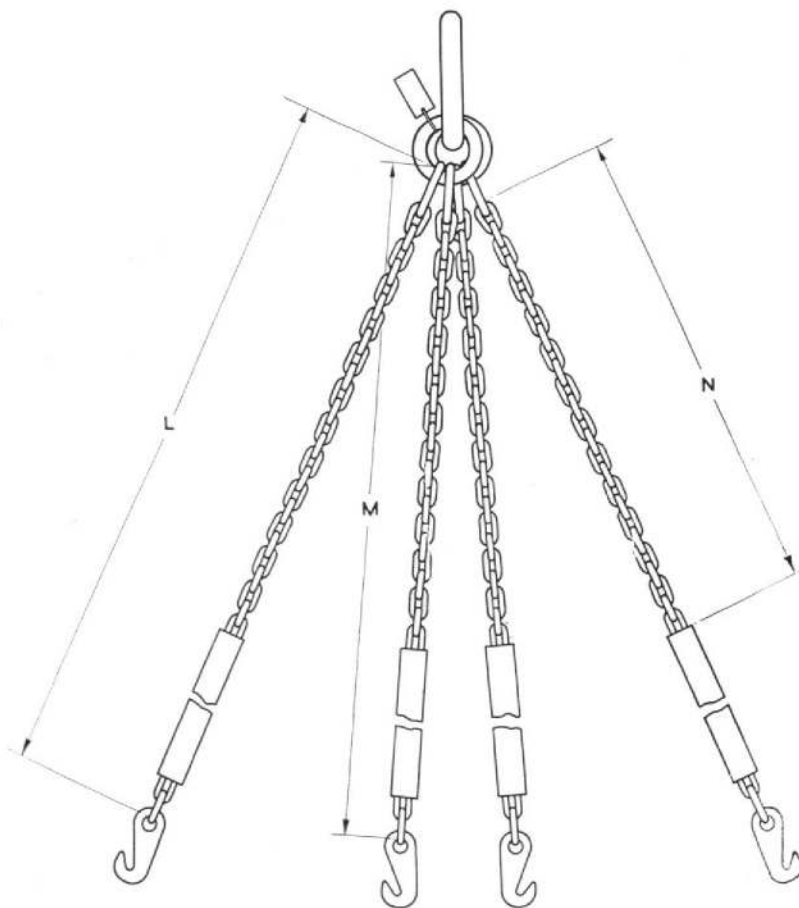

A.P. Reference 2817A, Vol. 1, and Vol. 6, Part 1, Sect. 11

Stores Ref. 4L/2647

Classification 2

Drawing No. G.M./C/3435

Dimensions

Length "L" 6 ft. 0 in.

Length "M" 5 ft. 6 in.

Length "N" 2 ft. 0 in

Brief description This sling is used for lifting uncased bombs. It consists of four high carbon steel chain legs, each with a lifting hook at the bottom end, and connected in pairs to two intermediate rings at the top; a main ring carries the two intermediate rings. Each leg is covered with leather sheathing up to 2 ft. from the top end. The maximum safe working load of the sling is 4,000 lb. and the vertical safe working load of each leg is 1,000 lb.

RESTRICTED

ITEM 31

TROLLEY, BOMB, TYPE C, Mk. 3

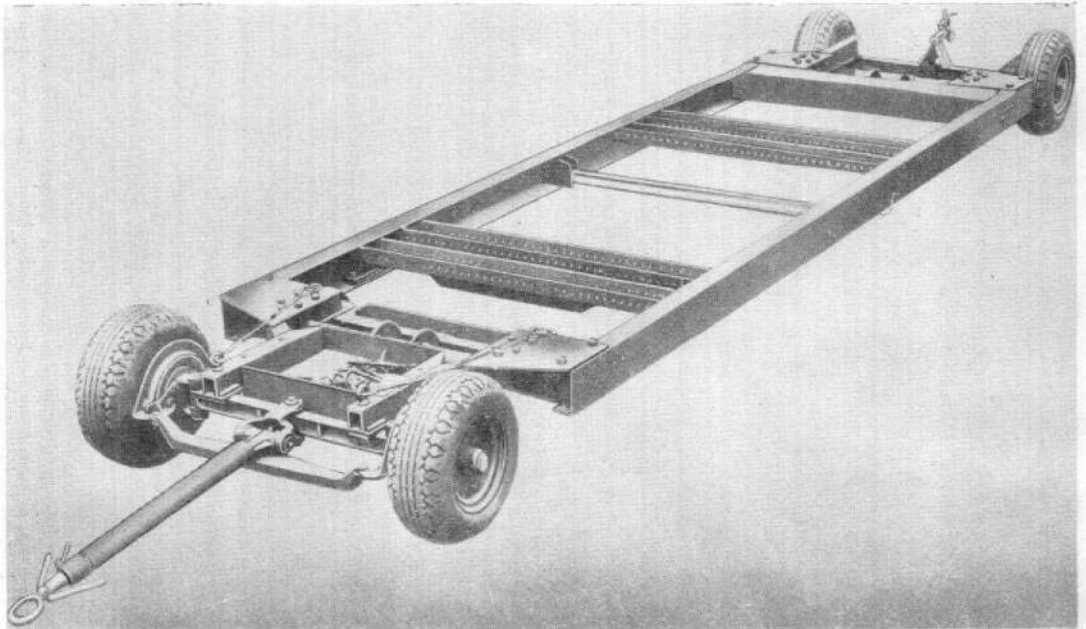

A.P. Reference 1664D (2nd Edn.), Vol. 1, Part 1, Sect. 1, Chap. 1

Stores Ref. 4G/2463

Classification 2

Overall dimensions

Length 15 ft. 8 in.

Width 4 ft. 0 in.

Height 3 ft. 8 in.

Weight 11 cwt. 2 qr. 19 lb.

Brief description This trolley is used for transporting, (1) two 2,000 lb. bombs, (2) one 4,000 lb. "A" mine, (3) three 1,000 lb. bombs, (4) six 500 lb. bombs, (5) eight 250 lb. bombs. The trolley is steered by lateral movement of the tow-bar, and brakes are applied to the front wheels when the tow-bar is in the horizontal position, and also if the tow-bar is pushed backwards from the vertical. When the trolley is being towed, the brakes are released by the pull of the tow-bar eye.

(A.L.29, Sep. 56)

ITEM 32

SLING, BOMB

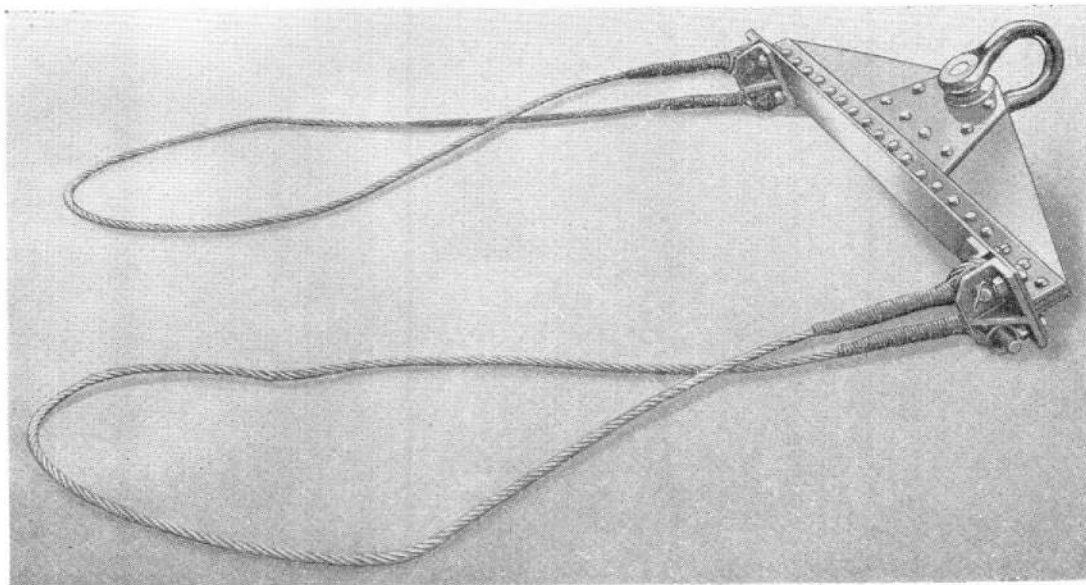

A.P. Reference 1664C, Vol. 1, Sect. 5

Stores Ref. 4L/2567

Classification 2

Overall dimensions

Length 5 ft.

Width 6½ in.

Height 1 ft. 6 in.

Weight

Brief description This bomb sling is for use with 12,000 lb. and 22,000 lb. bombs. The bomb is supported within two steel wire ropes suspended from a built-up steel girder.

RESTRICTED

SLINGS, ENDLESS ROPE

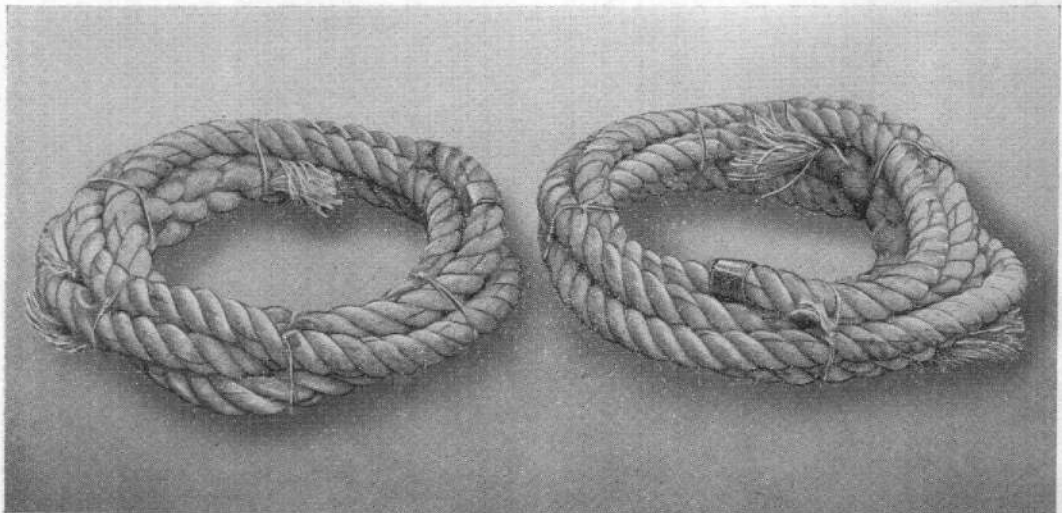

A.P. Reference 2817A, Vol. 1, and Vol. 6, Part 1, Sect. 11

Stores Ref. 4L/2566 and 2565

Classification 2

Drawing No. G.M.6329A—B

Overall Dimensions, Weight and S.W.L.

Ref. No.	Length	S.W.L.	Weight
4L/2566	24 ft.	4,700 lb.	25 bl.
4L/2565	30 ft.	4,700 lb.	30 lb.

Brief description Sling Ref. No. 2566 is used when handling 4,000 lb. bombs, and sling Ref. No. 2565 is used with 4,000 lb. sections of 12,000 lb. bombs.

ITEM 34

HOIST, BOMB LOADING, TYPE C

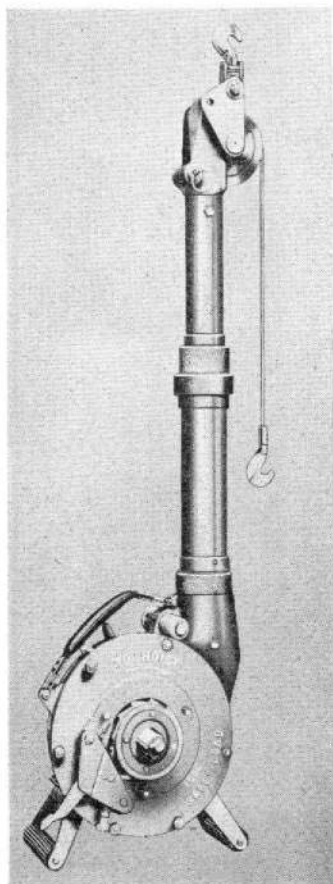

A.P. Reference 1664C, Vol. 1, Sect. 4, Chap. 3

Stores Ref. 49C/4232153

Classification 2

Overall dimensions (operating position)

Length 1 ft. 3 $\frac{1}{4}$ in. **Width** (without handle) 8 $\frac{1}{4}$ in. **Height** 4 ft. 7 $\frac{1}{4}$ in.

Weight 40 lb.

Brief description This portable hoist is used for lifting and lowering bombs and bomb carriers into and from aircraft bomb stations. The hoist consists of an outer casing which contains a cable drum and gearing. The total length of the cable is 12 ft. 3 in. The equipment can be operated by hand, or driven by an electric or hydraulic drive unit. The maximum load for one hoist is 1,000 lb.

ITEM 35

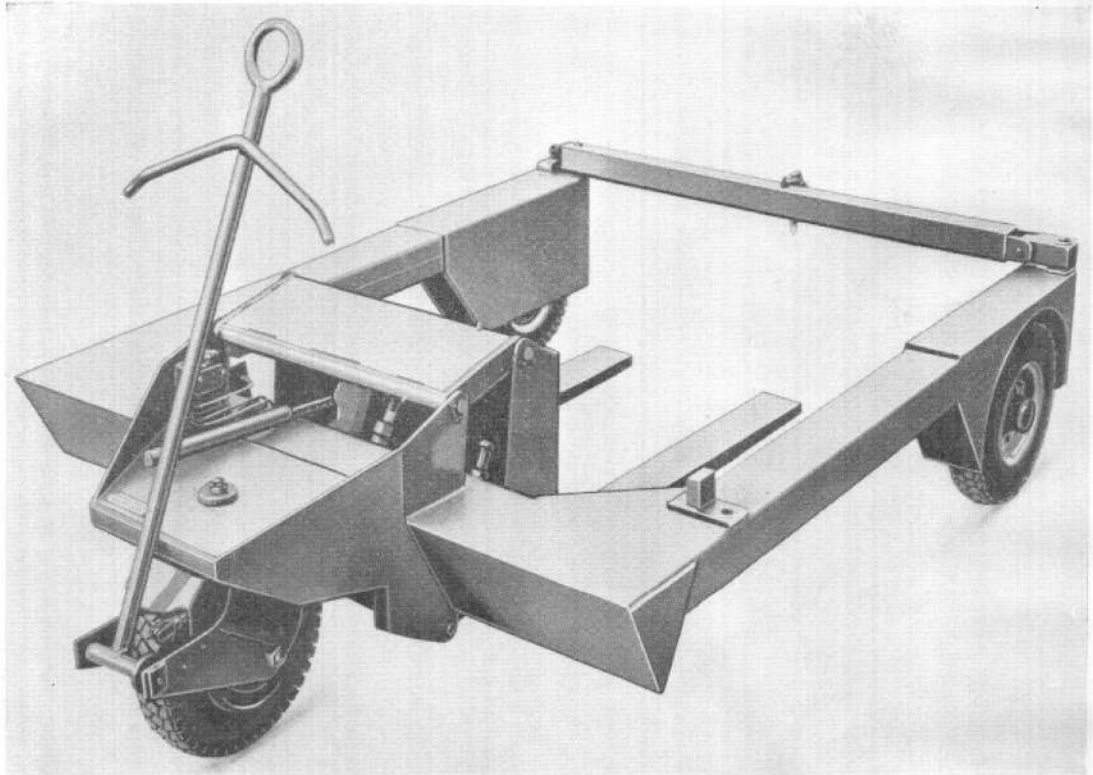
TROLLEY, TRANSPORTING, GUN PACKAGE

A.P. Reference 1664D (2nd Edn.), Vol. 1, Part 1, Sect. 1, Chap. 6

Stores Ref. 4G/5561

Classification I

Overall dimensions (towbar raised)

Length 7 ft. 7 in.

Width 5 ft. 1½ in.

Height 4 ft. 4 in.

Weight 7 cwt.

Brief description This trolley is used for transporting gun packages and ammunition to and from aircraft during re-arming operations at dispersal sites. The trolley consists of a three-wheeled chassis incorporating a fork lift assembly which can be raised hydraulically by the operation of a hand-operated pump, and lowered by opening a release valve. The gun package is first mounted on the cradle on the ground, and the trolley is wheeled into position so that the lowered lifting forks pass under the cradle. The pump is then operated to raise and support the cradle and gun package on the forks. The trolley has a towing arm at the front and a towing pin at the rear to enable a number of trolleys to be towed in train. The maximum safe load is 1,900 lb. and the hydraulic lift is 6 inches.

ITEM 36

TROLLEY SERVICING, HYDRAULIC, BOMB LOADING

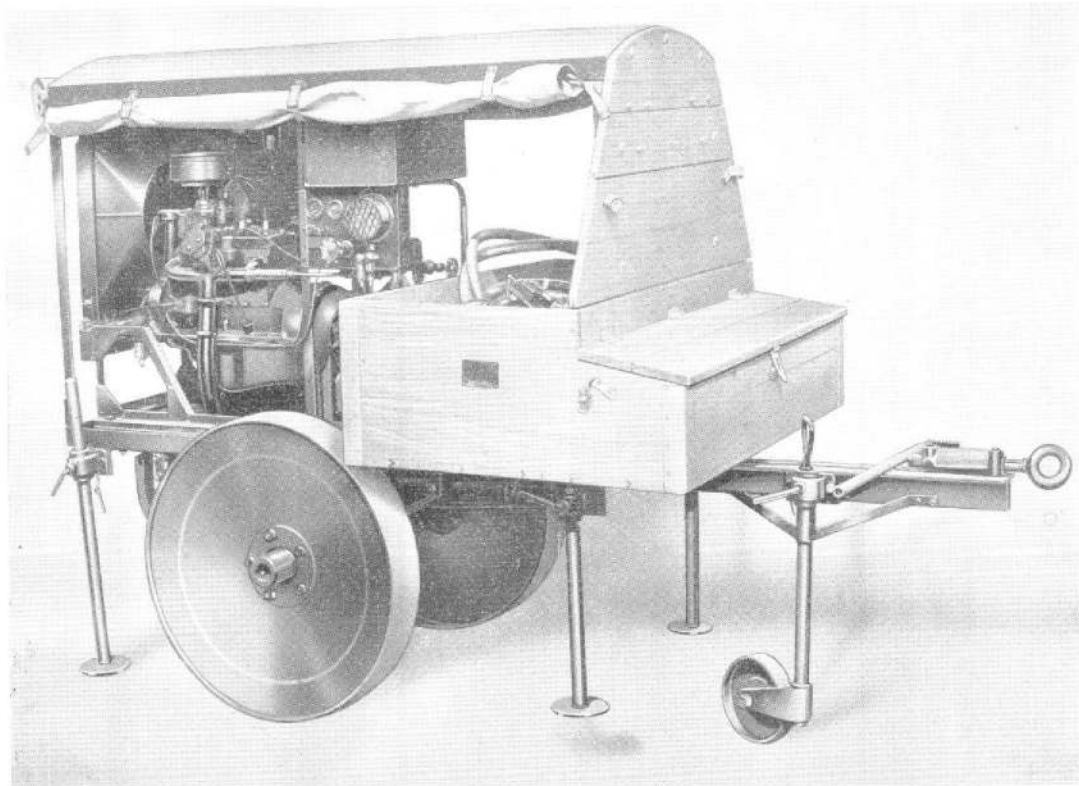

A.P. Reference 1664D (2nd Edn.), Vol. I, Part I, Sect. 2, Chap. 7

Stores Ref. 4F/1522

Classification I

Overall dimensions

Length (including tow-bar) 10 ft. 0 in.

Width 3 ft. 8½ in.

Height 5 ft. 7½ in.

Weight 10 cwt.

Brief description This trolley is used to supply power to drive hydraulic bomb-loading winches. The trolley carries a 10 h.p. Ford internal combustion engine, to which is directly coupled a Dowty P.E. Type 1250A hydraulic pump. The pump is fed from an oil reservoir tank mounted at one side of the chassis, and the front end of the chassis supports a winch and hose stowage box. Drop legs, tail skid, and a jockey wheel for use when the trolley is moved by hand, are fitted to the chassis.

RESTRICTED

ITEM 37

SLING, BOMB, THREE-LEGGED

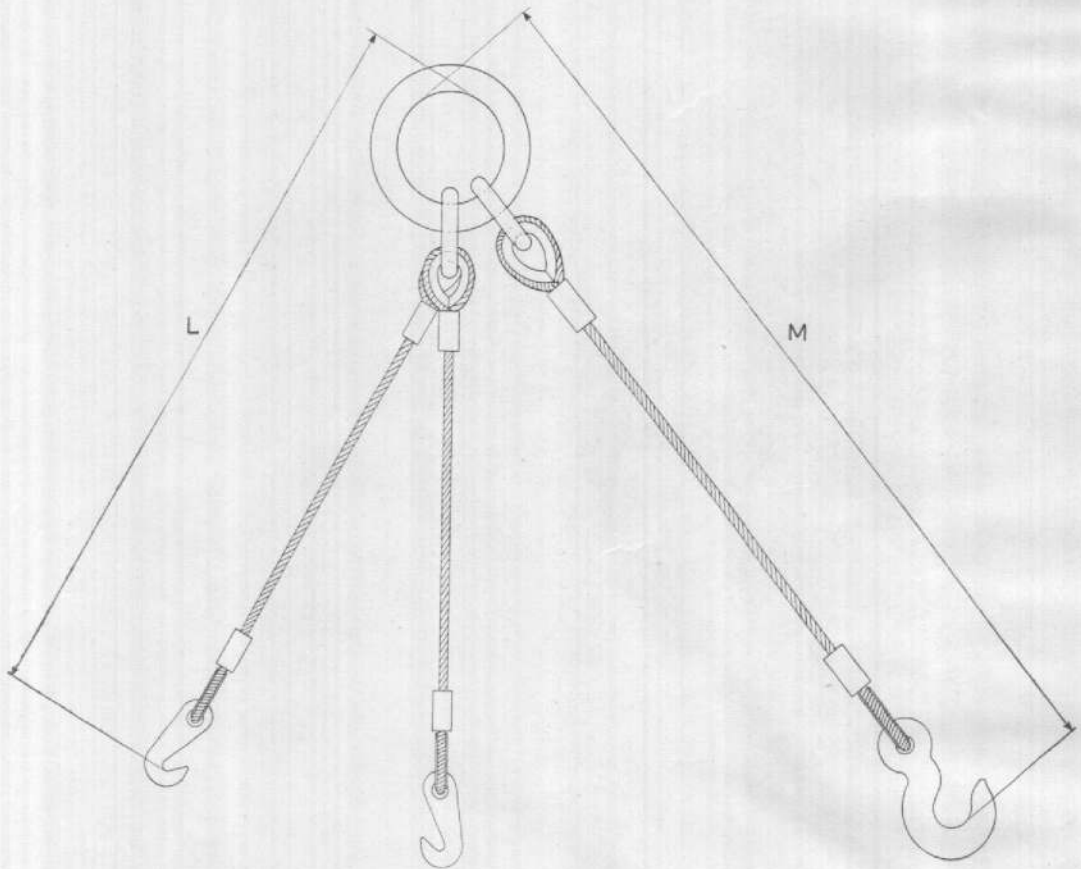

A.P. Reference 2817A, Vol. 1, and Vol. 6, Part 1, Sect. 11

Stores Ref. 4L/2666

Classification 2

Drawing No. G.M./D/1702

Dimensions

Short legs—Length 'L' 2 ft. 9½ in. Wire rope circumference 1½ in.
 Long leg—Length 'M' 3 ft. 5 in. Wire rope circumference 1½ in.

Brief description This standard sling is used for lifting 1,000 lb. bombs during the preparation of Canberra aircraft bomb loads in missile preparation areas. The sling consists of a main ring which carries two intermediate rings, to which are connected three wire rope legs fitted with hooks at their bottom ends; the two short legs are connected to one ring and the long leg to the other ring.

ITEM 38

STAND, SERVICING FOR Mk. 30 TORPEDO

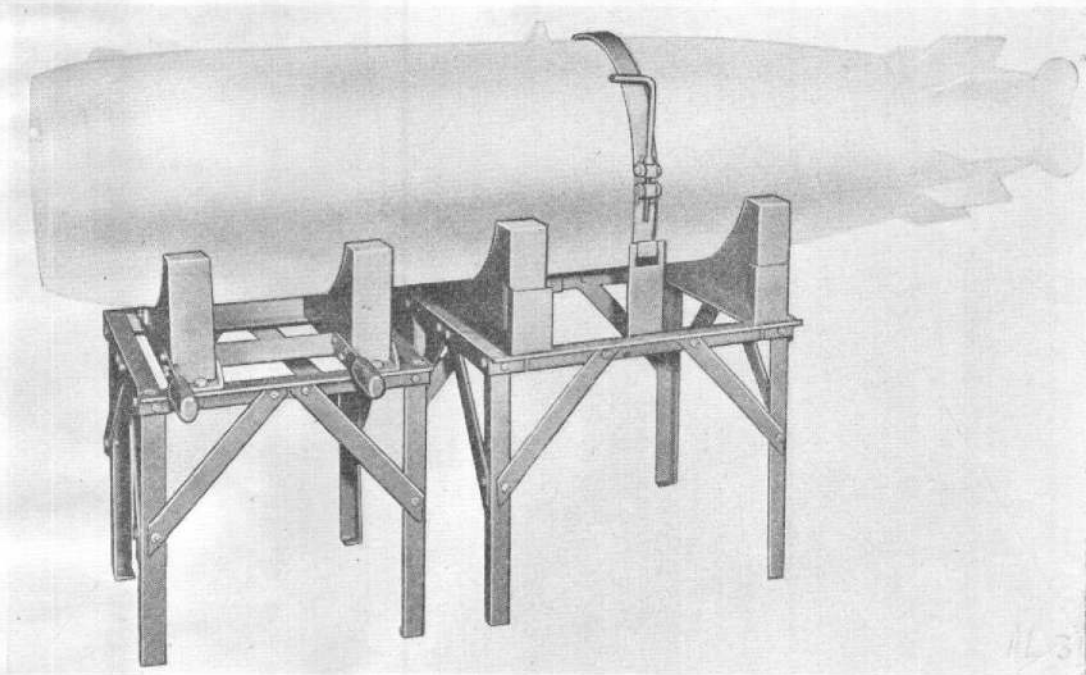

A.P. Reference 4483A

Stores Ref. N.I.V.

Overall dimensions

Body stand	Length 2 ft. 2 in.	Width 1 ft. 11 in.	Height 2 ft. 4 $\frac{1}{2}$ in.
Nose/tail stand	Length 1 ft. 8 in.	Width 1 ft. 11 in.	Height 2 ft. 4 $\frac{1}{2}$ in.

Weight 250 lb. (approx.)

Brief description This stand is used for servicing, testing and demonstrating the 18 in., Mk. 30 torpedo and consists of two parts, the body stand and the nose/tail stand. The body stand is provided with two wooden blocks shaped to form a cradle for the torpedo body, and a metal strap for securing the body to the stand. The nose/tail stand is provided with two pairs of wooden blocks shaped to form cradles for either the nose or the tail of the torpedo; these blocks are fitted with handles to facilitate the movement of the nose or tail after its detachment from the torpedo body.

RESTRICTED

ITEM 39

CRADLE, TRANSPORTING AND STORAGE, FOR 30mm. ADEN GUN

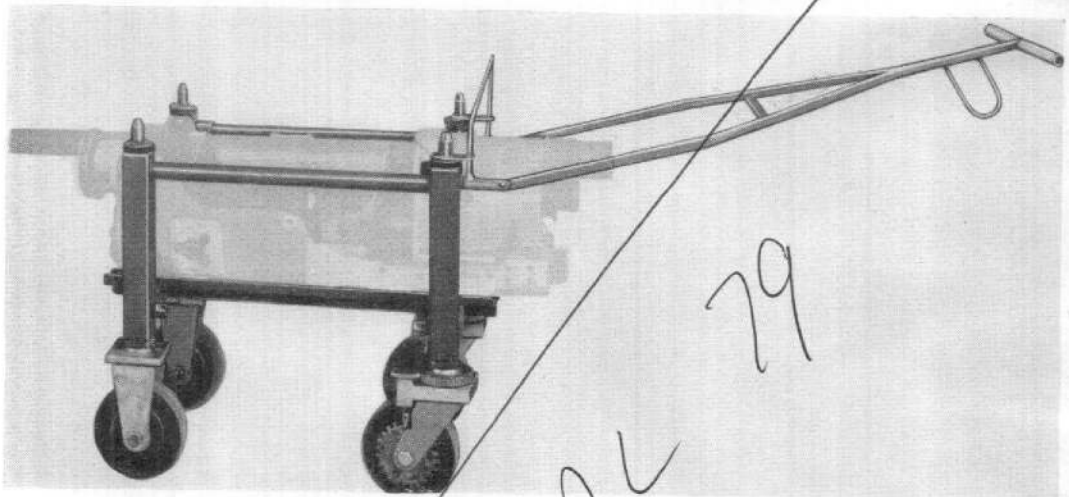

A.P. Reference 1664D (2nd Edn.), Vol. I, Part I, Sect. I, Chap. 10

Stores Ref. 4G/5455

Classification I

Overall dimensions

Length 1 ft. 3 $\frac{1}{8}$ in.

Width 1 ft. 2 in.

Height 1 ft. 2 in.

Weight (bare) 27 lb. 5 oz.
(with accessories) 3 qr. 20 lb. 15 oz.

Brief description This cradle is used for supporting the 30 mm. Aden gun during its movement by air or road transport, and for carrying the gun to and from aircraft at dispersal or during its servicing in the armoury. The cradles can be stacked and used also for supporting the guns during storage, and for this purpose they are adapted to fit one upon the other, up to a maximum of four tiers, and secured laterally by catches. Accessories, which can be attached to the cradle as required, include two lifting handles, a towing handle and four solid rubber-tyred wheels, two of which are castoring. The illustration above shows the cradle fitted with the towing handle and mounted on the wheels.

ITEM 40

DISPENSER, AMMUNITION, FOR CANBERRA Mk. 6 and 8 GUN PACK

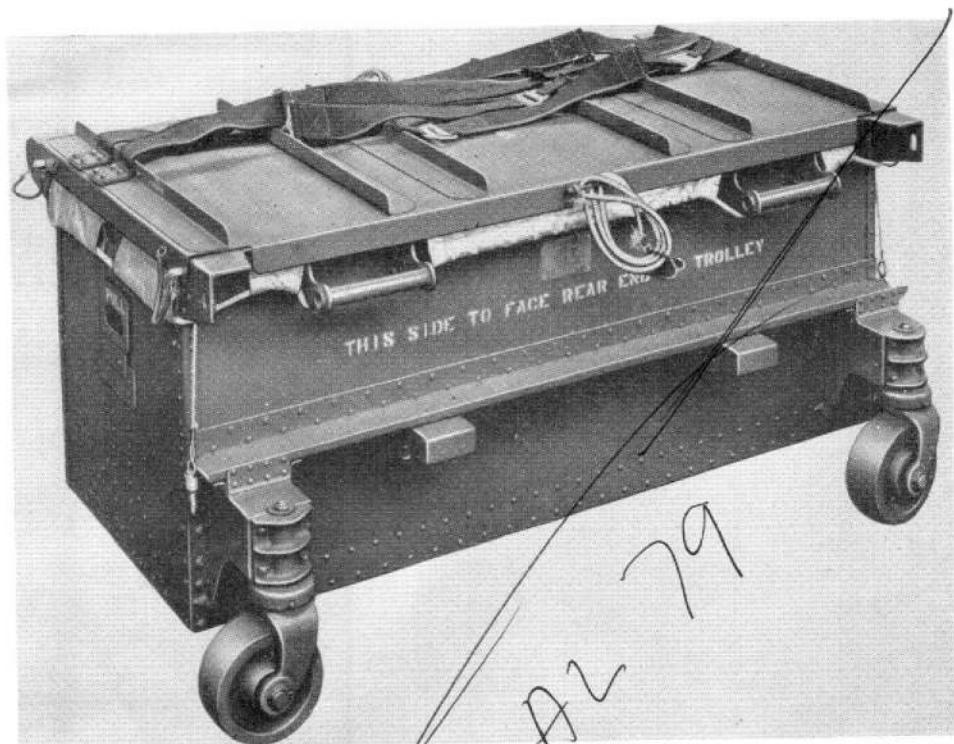

A.P. Reference 1664D (2nd Edn.), Vol. I, Part I, Sect. I, Chap. II

Stores Ref. 26FZ/95430

Classification I

Overall dimensions

Length 4 ft. 0 in.

Width 2 ft. 9 in.

Height 2 ft. 0 in.

Weight 3 cwt. 1 qr.

Brief description This dispenser is used for the conveyance of ammunition to and from the Canberra Mk. 6 and 8 gun pack when the pack is installed in an aircraft. Two dispensers are required to arm one pack, and these are carried to the aircraft on the gun package transporting trolley (ITEM 35). Each dispenser consists of a fabricated sheet-metal container having compartments for two separate ammunition belts, each of 525 rounds, and is covered by a detachable lid. The dispenser has four lifting handles, and is mounted on four castor wheels to facilitate its movement in the vicinity of the aircraft. Webbing straps attached to the lid of each dispenser are used to secure four gun boxes and two B.F.M. chests on the top of the two dispensers when mounted on the trolley.

RESTRICTED

ITEM 41

STAND, STORAGE, FOR CANBERRA Mk. 6 AND 8 GUN PACK

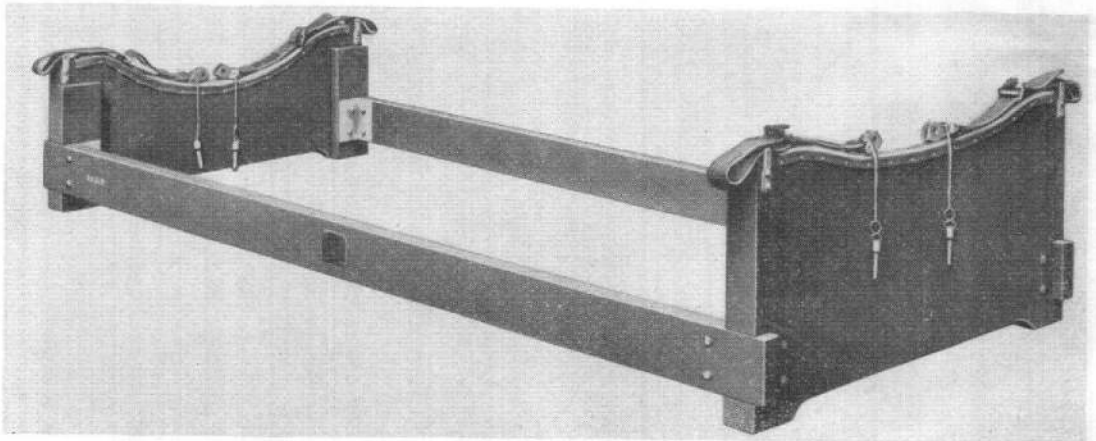

A.P. Reference 4483A, Vol. I, Part I, Sect. I, Chap. II

Stores Ref. 26FZ/95435

Classification 2

Overall dimensions

Length 8 ft. 10 in.

Width 3 ft. 8 in.

Height 1 ft. 8 in.

Weight 125 lb.

Brief description This stand is used to support the Canberra gun pack during storage. It consists of a rectangular wooden frame, the ends being shaped and padded with rubber to form a cradle for the gun pack, which is secured to the stand by four adjustable straps fitted one at each corner of the frame.

ITEM 42

**STAND, SERVICING, FOR CANBERRA Mk. 6 AND 8 GUN
PACK AND CANBERRA PHOTOFLASH DISCHARGER CRATES**

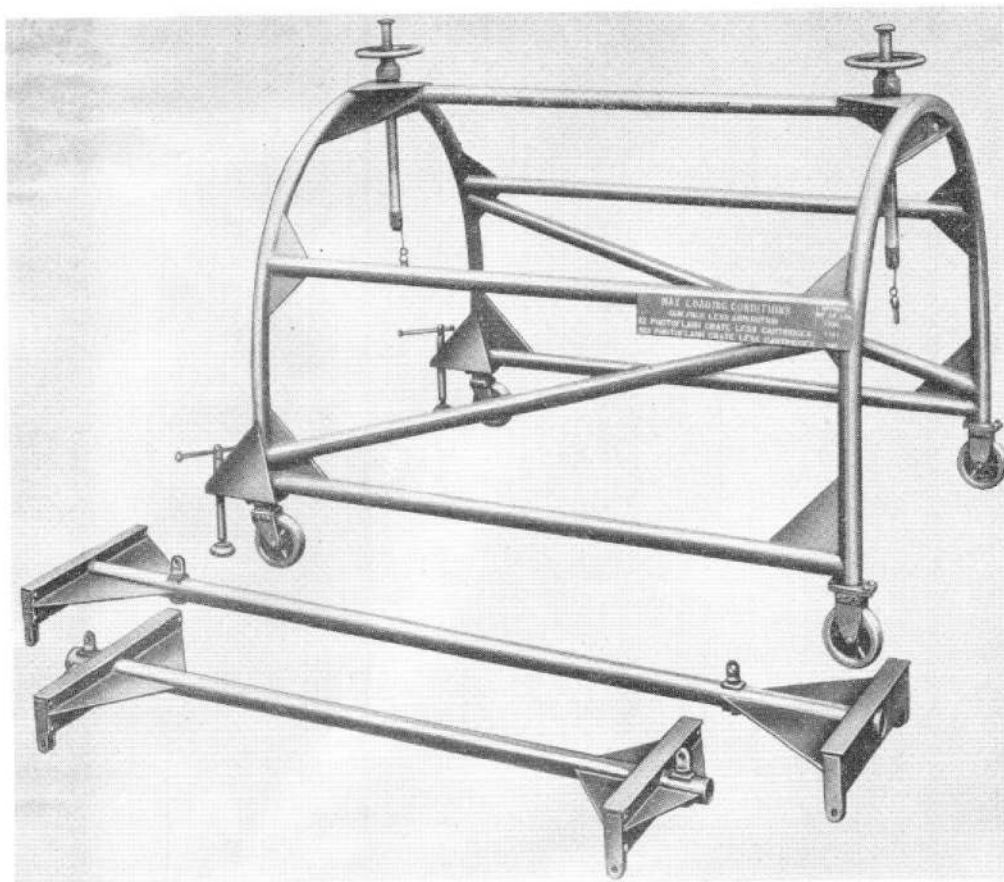

A.P. Reference 4483A, Vol. 1, Part 1, Sect. 1, Chap. 12

Stores Ref. 26FZ/95439

Classification I

Overall dimensions and weight

	Length	Width	Height	Weight
Stand	8 ft. 0 in.	6 ft. 4 in.	5 ft. 6 in.	609 lb.
Bridge adapter (1)	10 ft. 0 in.	2 ft. 2 in.	11 in.	96 lb.
Bridge adapter (2)	7 ft. 5 in.	2 ft. 4 in.	8 in.	82 lb.

Brief description This mobile stand is used to support the Canberra gun pack during servicing and, by using the two bridge adapters provided, it will support also the Canberra photoflash discharger crates. The stand is of all-welded tubular steel construction and straddles the gun pack or crate which is supported centrally by two screw hoists operated by hand wheels; a fork end at the bottom of each hoist is fitted with a quick-release pin to engage on the lifting lugs of the gun pack or the bridge adapter. The stand is mounted on four wheels, two of which are castoring, and is fitted with two stabilising screw jacks at one end.

RESTRICTED

ITEM 43

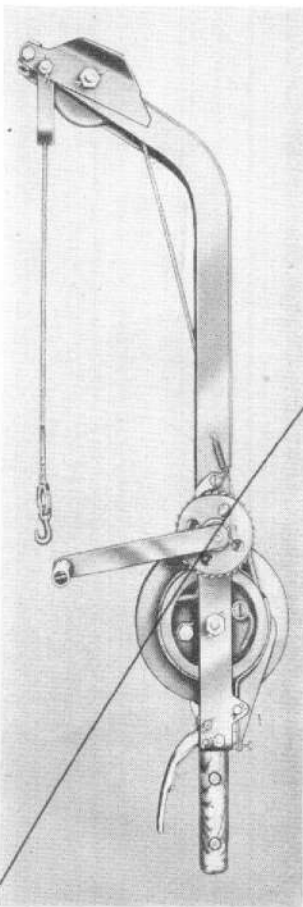
HOIST, BOMB, TYPE B**A.P. Reference** 1664C, Vol. 1, Sect. 4, Chap. 2**Stores Ref.** 4GC/2819**Classification** 2**Overall dimensions****Height** 3 ft. 1 in.**Width** (without crank handle) 1 ft. 1 in.**Depth** (without crank handle) 6½ in.**Weight** 23 lb.

Brief description The Type B bomb hoist is used for raising and lowering bombs to and from bomb carriers installed in aircraft. The hoists are used in pairs, one hoist being attached to each side of the carrier. Usually, a belt sling with a lifting ring at each end is placed under the bomb to be raised or lowered, and the hoist cables are hooked on to the rings. The maximum load for a pair of hoists is 1,000 lb. The hoist is used also for lifting 30 mm. Aden guns into Javelin aircraft.

ITEM 44

TROLLEY, PLATFORM, AIRCRAFT SERVICING, G.P. (WITH CANOPY)

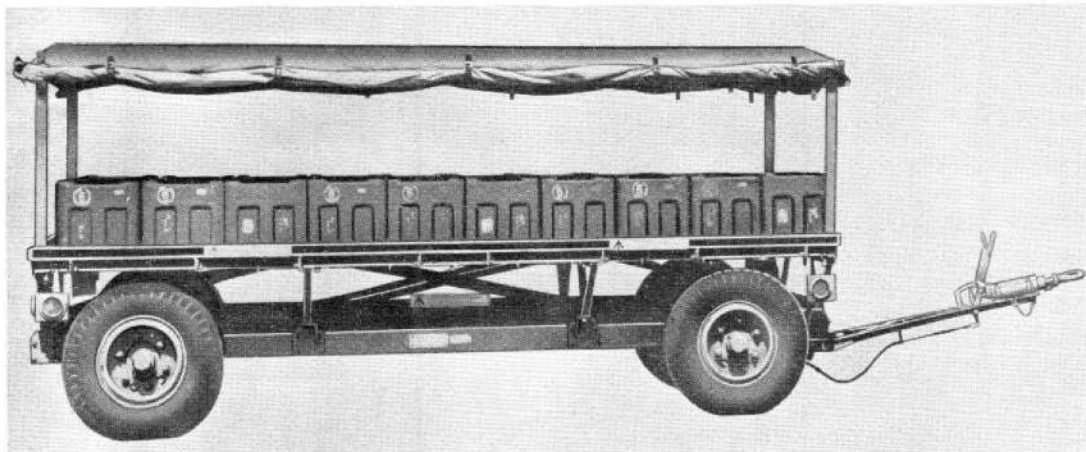

A.P. Reference 1664D (2nd Edn.), Vol. 1, Part 1, Sect. 1, Chap. 9

Stores Ref. 4F/2061

Classification 2

Overall dimensions

Length (with towbar) 18 ft. 6½ in.

Width 5 ft. 0 in.

Platform height 2 ft. 7¾ in.

Weight (with canopy) 15 cwt. 3 qr. (less canopy) 14 cwt. 2 qr.

Brief description This trolley is used during aircraft servicing for transporting heavy aircraft components, aircraft guns, boxed ammunition, etc. The trolley consists of a Mk. 2 Type C standard chassis (SECTION 5, ITEM 32) on which is mounted a metal platform 12 ft. long and 5 ft. wide. A canvas canopy (Stores Ref. 4F/2298) and a canopy support (Stores Ref. 4F/2299) are fitted as additional accessories when the trolley is used solely for transporting guns and ammunition; the canopy adds 3 feet to the height of the trolley. The load supported on the trolley must not exceed 35 cwt. The illustration above shows the trolley fitted with the canopy and carrying ammunition boxes.

RESTRICTED

ITEM 45

STAND, SERVICING, FOR MULTIPLE BOMB CARRIERS

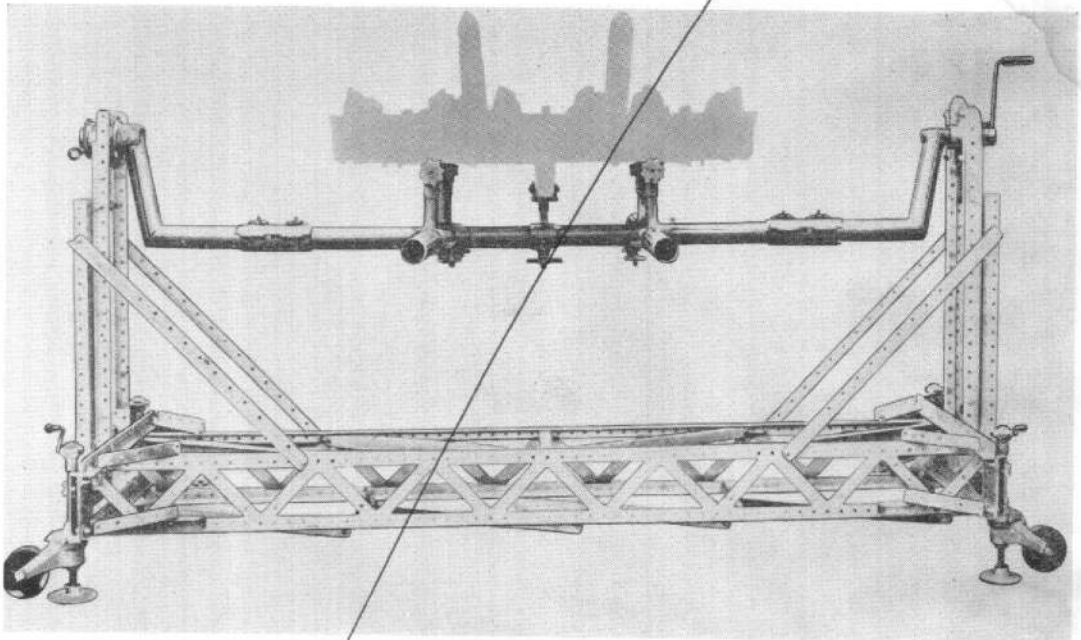

A.P. Reference 4483A, Vol. I, Part I, Sect. 4, Chap. 5

Ref. No. 4G/5791

Classification 2

Overall dimensions

Length 10 ft. 10 in.

Width 3 ft. 6 in.

Height 6 ft. 8 in.

Weight 480 lb.

Brief description This stand is used for supporting multiple bomb and mine carriers during bay servicing, the carriers being too heavy for normal bench servicing. The stand is a Basix structure consisting of a base frame, supported on four wheel and jack units, with vertical end members for supporting a main beam which has adjustable arms for mounting the carrier. A rotary gear unit is mounted at the top of one end member, and is fitted with a handle for turning the main beam as required during servicing operations.

ITEM 46

CRANE, GANTRY, BOMB HOISTING

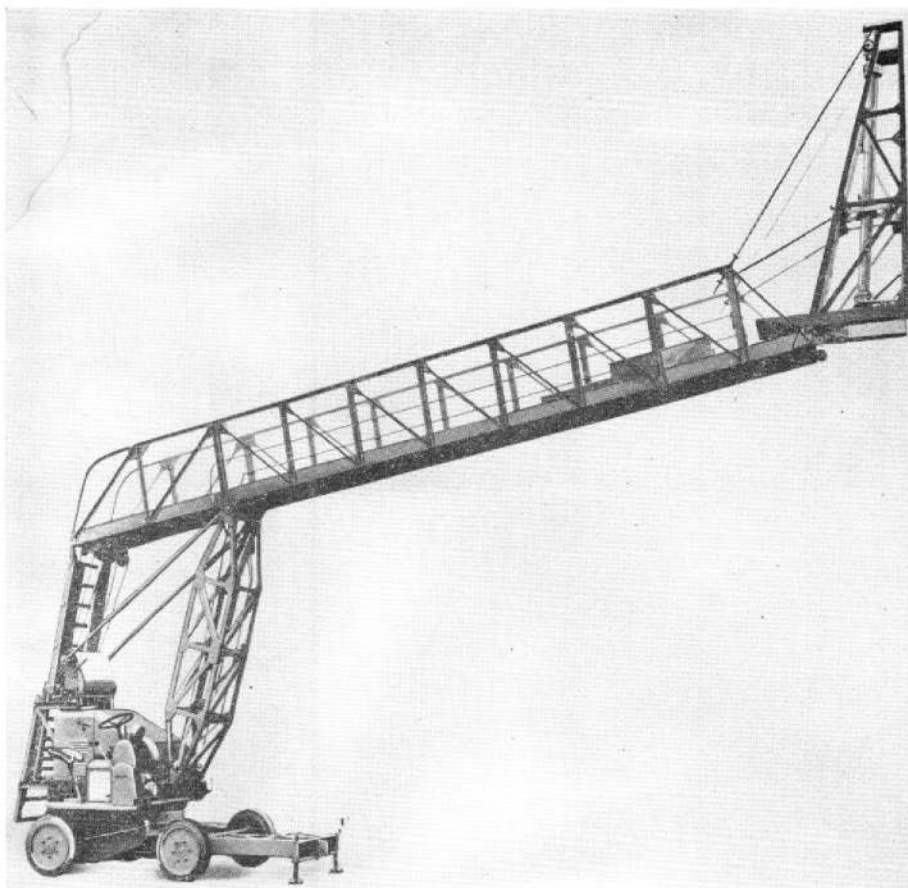

A.P. Reference 1664D (2nd Edn.), Vol. 1, Part 1, Sect. 2, Chap. 8

Ref. No. 16A/1931

Classification I

Overall dimensions

Length 32 ft. 9 in.

Width 6 ft. 1 in.

Height (gantry lowered) 21 ft. 4 in.
(gantry raised) 29 ft. 4 in.

Weight 3 tons 8 cwt.

Brief description This crane is used in conjunction with ground handling bomb loading equipment and aircraft bomb hoisting gear for loading bombs and similar stores on to Valiant aircraft. The crane consists of a self-propelled, solid-tired chassis carrying an adjustable gantry on the end of which is mounted a hydraulic jack. The gantry can be traversed hydraulically through an arc of 30 deg., and raised or lowered manually through 30 deg. A J.A.P. Model 6 gasoline engine drives the hydraulic pump and provides the power for moving the vehicle; no gearbox is fitted and the vehicle is suitable only for short journeys on hard level surfaces at a maximum speed of $2\frac{1}{4}$ m.p.h. The vehicle can be towed at 12 m.p.h. after disconnection of the transmission and steering. After the foot of the hydraulic jack has been positioned on the aircraft, the equipment is capable of handling a store weight of 14,000 lb. The maximum working pressure in the hydraulic system is 4,000 lb. per sq. in.

RESTRICTED

ITEM 47

PACKS, POWER, FOR BOMB HOISTING JACKS, Mk. 1 & 2

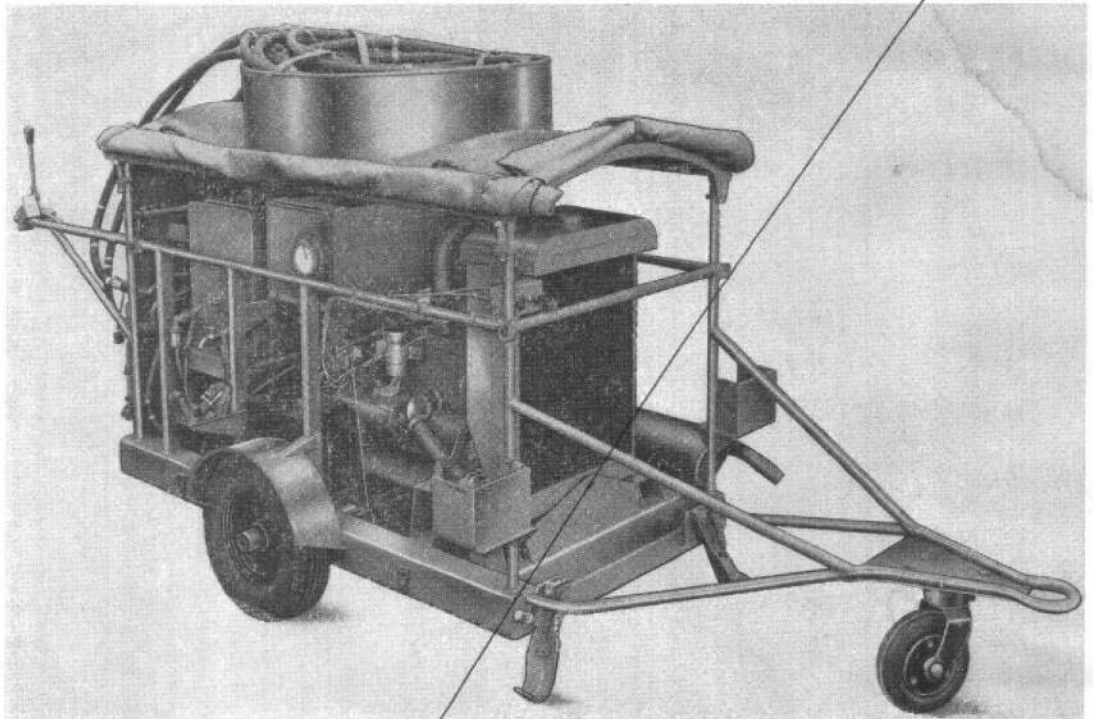

A.P. Reference 1664D (2nd Edn.), Vol. 1, Part 1, Sect. 2, Chap. 11

Ref. No. 4G/5965 (Mk. 1): 4G/5966 (Mk. 2)

Classification I

Overall dimensions

Length 10 ft. 2 in.

Width 3 ft. 7 in.

Height 4 ft. 3 in.

Weight 920 lb.

Brief description These power packs are used to supply hydraulic pressure to twin bomb hoisting jacks (ITEM 48) during bomb loading operations on Vulcan or Shackleton M.R.3 aircraft. The Mk. 2 pack consists of a two-wheeled chassis on which is mounted a hydraulic pump driven by a 10 h.p. Ford water-cooled industrial engine, a hydraulic fluid reservoir, and two sets of twin hoses with self-sealing couplings for connection to the jacks. Provision is made for carrying the jacks on the power pack. A castor wheel is fitted below the towing arm to facilitate manoeuvring, and two retractable legs at the front and one telescopic strut at the rear stabilise the pack when in use. The maximum working pressure required for operating the jacks is 3,000 lb. per sq. in. The Mk. 1 power pack is similar to the Mk. 2 pack, but is powered by a Coventry Victor Type AN4 Mk. 2 engine.

(A.L.36, May 58)

ITEM 48

JACK, HOISTING, BOMB CARRIER (VULCAN)

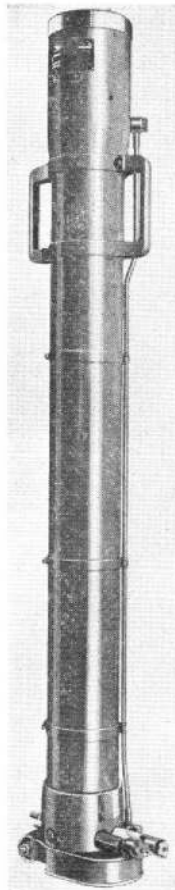

A.P. Reference 1664D (2nd Edn.), Vol. 1, Part 1, Sect. 2, Chap. 10

Ref. No. 26DC/95090

Classification I

Overall dimensions

Length 4 ft. 11 $\frac{1}{4}$ in.

Diameter 6 $\frac{1}{4}$ in.

Weight (empty) 110 lb.

Brief description These hydraulic jacks are used in pairs for hoisting loaded bomb carriers to the height necessary for their attachment in Vulcan aircraft. Each jack is of the two-ram type, and hydraulic pressure for its operation is supplied by a power pack (ITEM 47) to which it is connected by twin hoses; the jacks are stowed on the power pack when not in use. The jack has a hydraulic lift of approximately 91 inches, and is fitted with a locking valve to prevent retraction of the rams in the event of a pressure supply failure. A relief valve controls the maximum working pressure of the jack at 3,000 lb. per sq. in.

RESTRICTED

INDICATOR, COCKING TEST, SEVEN-WAY Mk. I



A.P. Reference 4483A, Vol. I, Part I, Sect. 4, Chap. 4

Ref. No. 5G/560

Classification 2

Overall dimensions

Length 3 in.

Width 3 in.

Height 5 in.

Weight 1 lb. 8 oz. : (with batteries) 2 lb. 10 oz.

Brief description This instrument is used to ensure that an E.M. release unit is correctly cocked when loaded with a store, by checking the continuity of the electrical circuit. A green light is illuminated to indicate a satisfactory check, and up to seven circuits can be checked simultaneously. The instrument can be used also to test the continuity of certain other armament electrical circuits. The indicator consists of a light alloy box containing two 2.4 volt batteries which are connected through wiring and an assembly of contacts to seven green lamps on the front of the box, a twelve-pole socket and a two-pole plug on the back of the box, and a push-button switch on the top of the box. The continuity of a circuit is checked by pressing the switch after connecting a cable between the plug or socket and the circuit under test; the appearance of a light indicates that the circuit is unbroken, and that the equipment is serviceable.

ITEM 50

RIGS, TEST, CARTRIDGE, ELECTRIC, ENGINE-STARTING, TYPES A & B

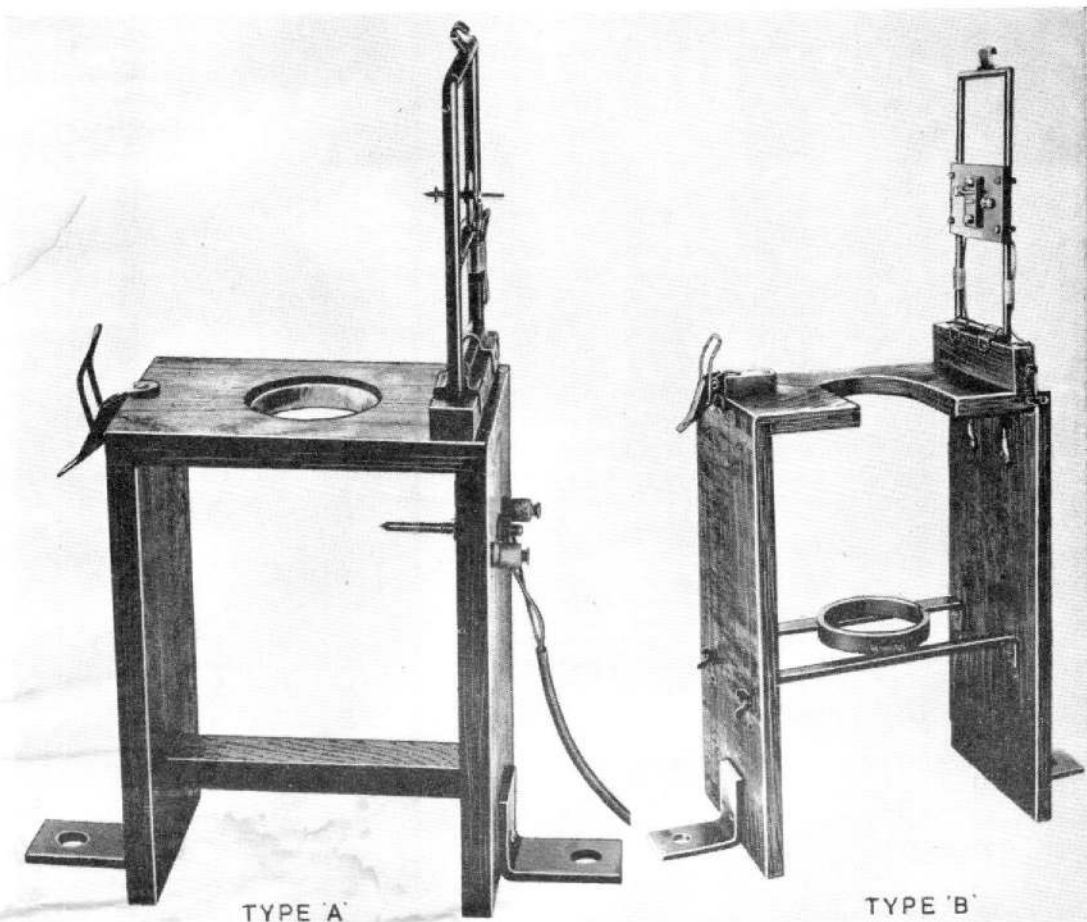

A.P. Reference 4483A, Vol. 1, Part 1, Sect. 5, Chap. 1
Ref. No. 4G/5629 (Type A) : 4G/5630 (Type B)

Classification 2

Overall dimensions and weight

	Length	Width	Height	Weight
Type A	1 ft. 3 in.	5 $\frac{3}{4}$ in.	1 ft. 1 in.	5 $\frac{3}{4}$ lb.
Type B	1 ft. 6 $\frac{1}{2}$ in.	8 in.	1 ft. 6 $\frac{1}{4}$ in.	10 $\frac{3}{4}$ lb.

Brief description These rigs are used for testing the electrical continuity of the primers in electric engine-starting cartridges; the Type A rig is for No. 8, 9 and 10 cartridges, and the Type B rig for No. 12 and 14 cartridges. The rigs are similar in design, consisting of a wooden stand on which is mounted a hinged arm fitted with spring-loaded contacts which are connected to terminals on the side of the stand. During a test, the cartridge is placed in an aperture in the top of the stand, and the arm is hinged over so that contact is made with the primer body and the cartridge cap. Electric current used for the test is fed to the terminals on each rig via a 50 ft. length of twin cable.

RESTRICTED

ITEM 51

STAND, SERVICING, EJECTION SEAT



A.P. Reference 4483A, Vol. 1, Part 1, Sect. 6, Chap. 1

Ref. No. 27L/1162

Classification 1

Overall dimensions

Length 3 ft. 4½ in.

Width 3 ft. 3 in.

Height 3 ft. 2 in.

Weight 106 lb.

Brief description This mobile stand is used to support an aircrew ejection seat after its removal from an aircraft for servicing. It consists of a tubular steel structure mounted on three pneumatic tyred wheels, one of which is castoring. The ejection seat is clamped to an adapter arm which is mounted on a hinge fitting at the top of the stand centre post; the seat and arm assembly can be tilted, turned, and secured in various positions during servicing. Two types of adapter arm are provided, one is 40 in. long for holding the Mk. 1, 2 or 3 ejection seat and is shown in the illustration above, and the other is 47½ in. long to suit the Mk. 4 seat.

ITEM 52

TRUCK, MOBILE, BOMB LOADING (SIMON)



A.P. Reference 1664D (2nd Edn.), Vol. 1, Part 1, Sect. 2, Chap. 13

Ref. No. 16A/2303

Classification I

Overall dimensions (with booms stowed)

Length 28 ft. 3 in.

Width 7 ft. 2 in.

Height 18 ft. 0 in.

Weight (less vehicle chassis) $2\frac{1}{2}$ tons (approx).

Brief description This truck is used in conjunction with ground handling bomb loading equipment and bomb hoisting gear for loading bombs and similar stores on to certain types of aircraft. It consists of a Bedford Type SLC 3/5 ton chassis on which is carried a platform assembly incorporating two booms and a working platform which can be raised and lowered, and rotated on a turntable, by hydraulic pressure supplied by a pump driven by a Coventry Victor Type AN4 Mk. 3 gasoline engine. At maximum height, the platform floor is 36 feet from the ground; the maximum working load of the platform is 750 lb. The hydraulic pump also supplies the pressure for operating a bomb hoisting jack which is mounted on the rear side of the working platform; the control levers and valves for operating the platform and the jack are mounted on the side of the turntable. The maximum working pressure for operating the jack is 4000 lb. per sq. in., a change-over valve and a pressure relief valve being fitted to enable the pressure to be controlled at 1200 lb. per sq. in. for operating the booms and turntable.

RESTRICTED

FRAME, LOADING, PHOTOFFLASH CONTAINER

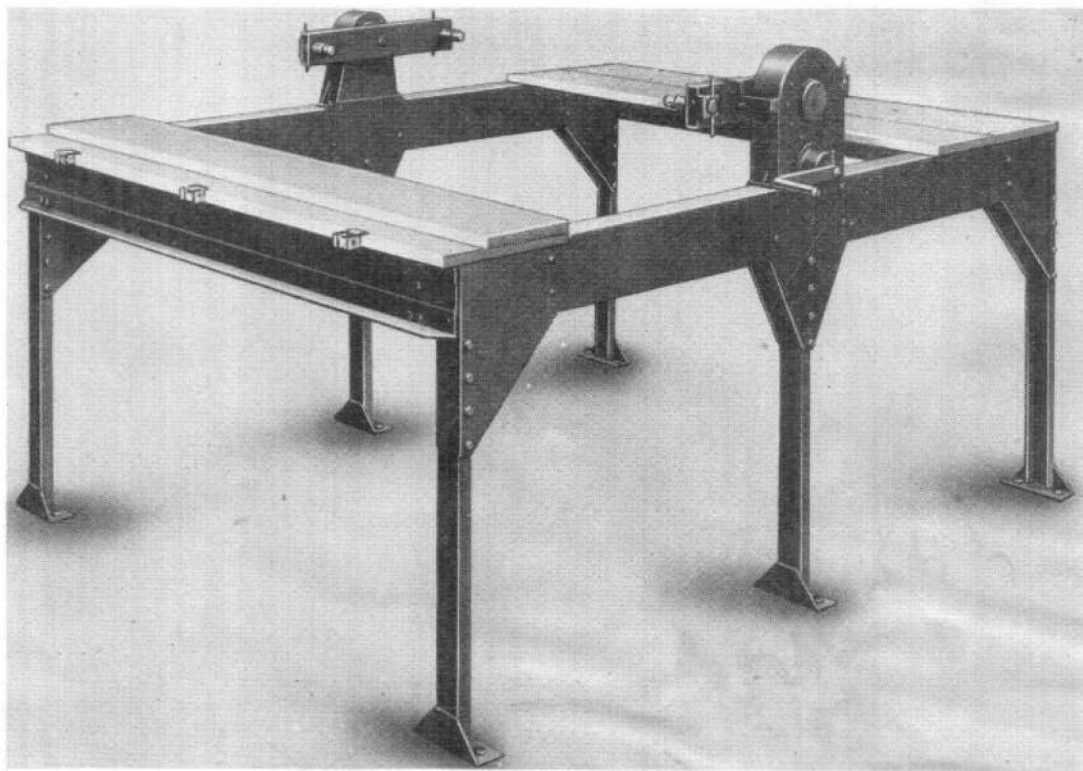

A.P. Reference 1664D (2nd End.), Vol. 1, Part 1, Sect. 2, Chap. 12

Ref. No. 4G/6090

Classification I

Overall dimensions

Length 10 ft. 6 in. **Width** 8 ft. 6 in. **Height** 4 ft. 6 in.

Weight 1750 lb.

Brief description This frame is used to facilitate the loading of either a Valiant, 28 stores, photoflash container or a Victor, 36 stores, photoflash container, and can be used also to support these containers during servicing. The frame is of steel construction and has two geared stanchion and beam assemblies mounted on the top for supporting and turning the container; screwed locating pins on the beams engage holes in the sides of the container. Each stanchion is provided with a handle for turning the container, and has a clutch mechanism which enables the container to be held in any desired position when the handle is released. Hinged platforms are attached to the frame and can be folded over the sides when not required.

ITEM 54

FRAME, TRANSIT, LOADED PHOTOFLASH CONTAINER

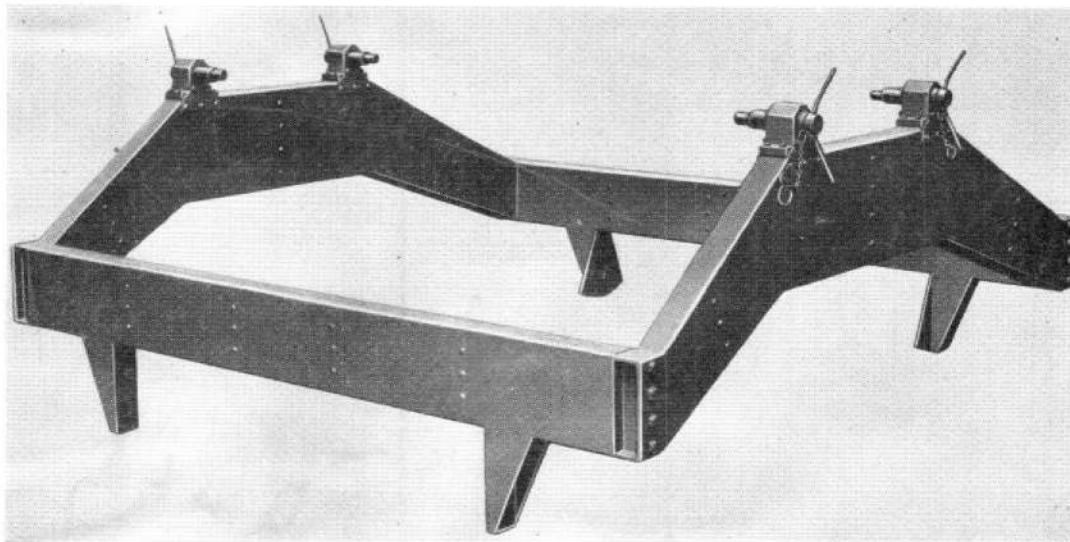

A.P. Reference 1664D (2nd Edn.), Vol. 1, Part 1, Sect. 1, Chap. 7, App. 1

Ref. No. 4G/6091

Classification 2

Overall dimensions

Length 8 ft. 0 in. **Width** 7 ft. 11 in. **Height** 2 ft. 3 in.

Weight 800 lb.

Brief description This frame is used to support either a Valiant, 28 stores, photoflash container or a Victor, 36 stores, photoflash container, when it is being transported on a Mk. 1 standard airfield bomb transporter (ITEM 1). The frame is of steel construction and has four screwed locating pins which engage in holes in the sides of the photoflash container. Four legs on the underside of the cross-members are used to locate the frame on the transporter chassis.

RESTRICTED

ITEM 55

HOIST, HEAVY AIRCRAFT COMPONENTS, 2½ cwt.

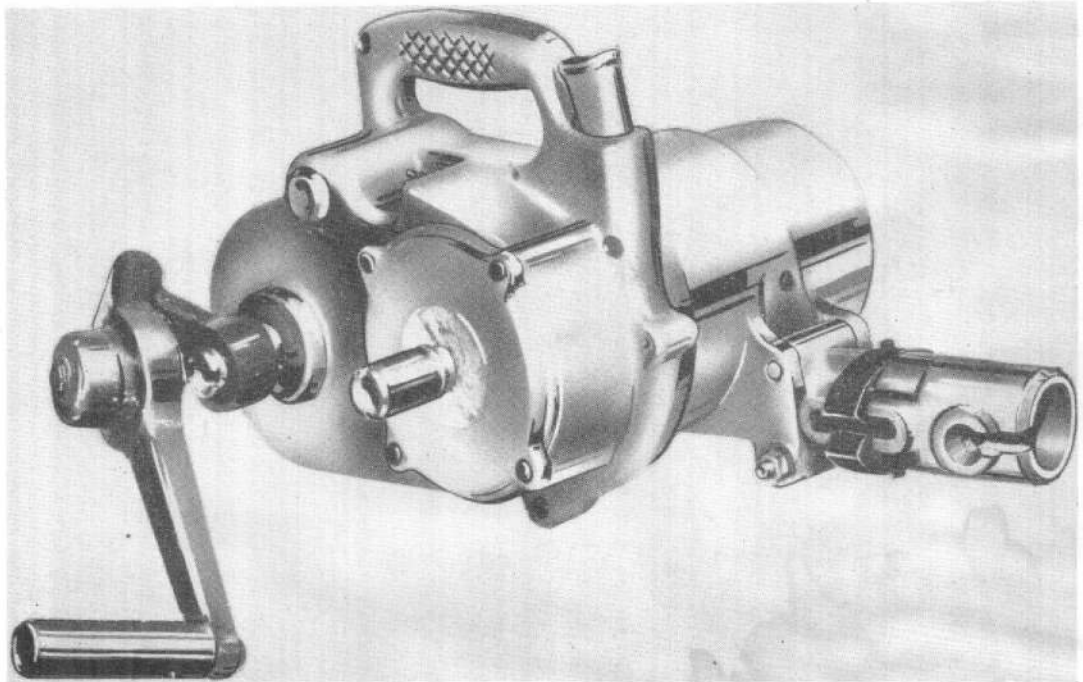

A.P. Reference 1641S, Vol. 1, Part 1, Chap. 7C, and
2817A, Vol. 1, and Vol. 6, Part 1, Sect. 8, Chap. 4

Stores Ref. 4GC/5699

Classification 2

Overall dimensions of winch

Length 1 ft. 4 in. **Width** 11¾ in. **Height** 9 in.

Weight of winch 22 lb.

Brief description This hoist has a lifting capacity of 2½ cwt. and is used for installing the 30 mm. Aden gun in Javelin aircraft. The hoist winch is mounted on a tripod positioned over the gun bay in the wing of the aircraft, the winch cable passing down through the gun bay for lifting the gun into position in the wing. The length of the winch cable is 25 ft. 6 in. Other applications of the hoist are given in Section 6, Item 29.

ITEM 56

CRADLE, LOADING AND TRANSPORTING, FOR HEAVY STORES—SHACKLETON Mk. 3

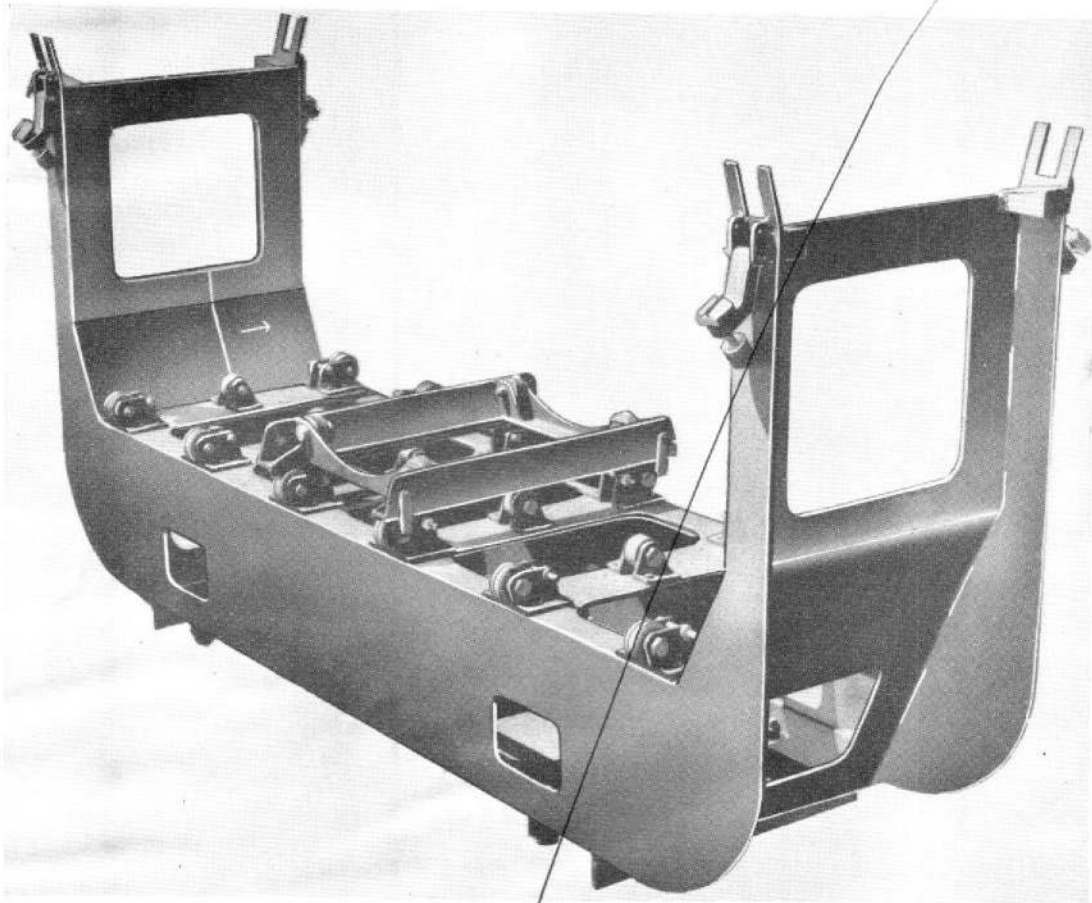

AC 76

A.P. Reference 1664D (2nd Edn.), Vol. 1, Part 1, Sect. 1, Chap. 12

Ref. No. 26FP/454

Classification 2

Overall dimensions

Length 7 ft. 2 in. **Width** 1 ft. 9 in. **Height** 3 ft. 4 in.

Weight 414 lb.

Brief description This cradle is normally mounted on the Type F, Mk. 1, bomb trolley (ITEM 8) and is used for the support and transport of heavy stores during operations such as servicing and testing, missile preparation, heavy carrier loading and preparation, and loading and off-loading the stores from aircraft. The cradle is a steel plate and angle section welded structure with support standards for the store carrier at each side, and is secured by clamps to the frame of the bomb trolley. The stores are carried on three cradle trolleys mounted on rollers on the bed of the cradle, between the standards. The upper surface of each trolley is shaped to suit the store and is fitted with four rollers on which the store can be rotated.

RESTRICTED

ITEM 57

CRADLE, LOADING AND TRANSPORTING, FOR MEDIUM STORES—SHACKLETON Mk. 3

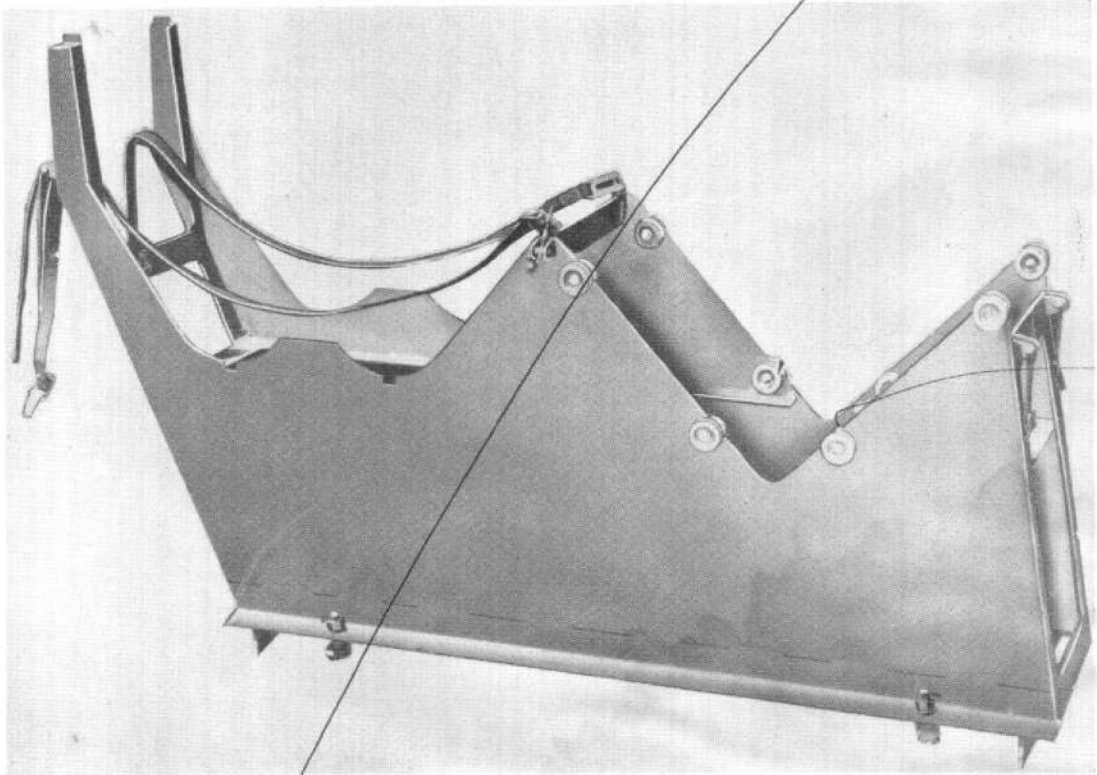

AC 26

A.P. Reference 1664D (2nd Edn.), Vol. 1, Part 1, Sect. 1, Chap. 13

Ref. No. 26FP/455

Classification 2

Overall dimensions

Length 5 ft. 6 in. **Width** 1 ft. 7½ in. **Height** 3 ft. 2 in.

Weight (approx.) 253 lb.

Brief description This cradle is normally mounted on the Type F, Mk. 1, bomb trolley (ITEM 8) and is used for the support and transport of medium stores during operations such as missile preparation, carrier loading and preparation, positioning a loaded carrier under an aircraft ready for hoisting, and receiving a store carrier during off-loading from an aircraft. The cradle is a steel plate and angle-section welded structure with a store carrier support standard at one side, and is secured by clamps to the frame of the bomb trolley. The stores are accommodated in the two bays of the cradle as formed by the shaping of the side plates. The V-shaped bay is provided with eight pairs of rollers on which the store rests and on which it can be rotated for correct positioning. The W-shaped bay accommodates up to five medium stores such as sonobuoys. Webbing straps secure the stores during transit.

ITEM 58

CRADLE, LOADING AND TRANSPORTING, FOR 8 in. PHOTOFLASH AND MULTI-STORE CARRIER—CANBERRA

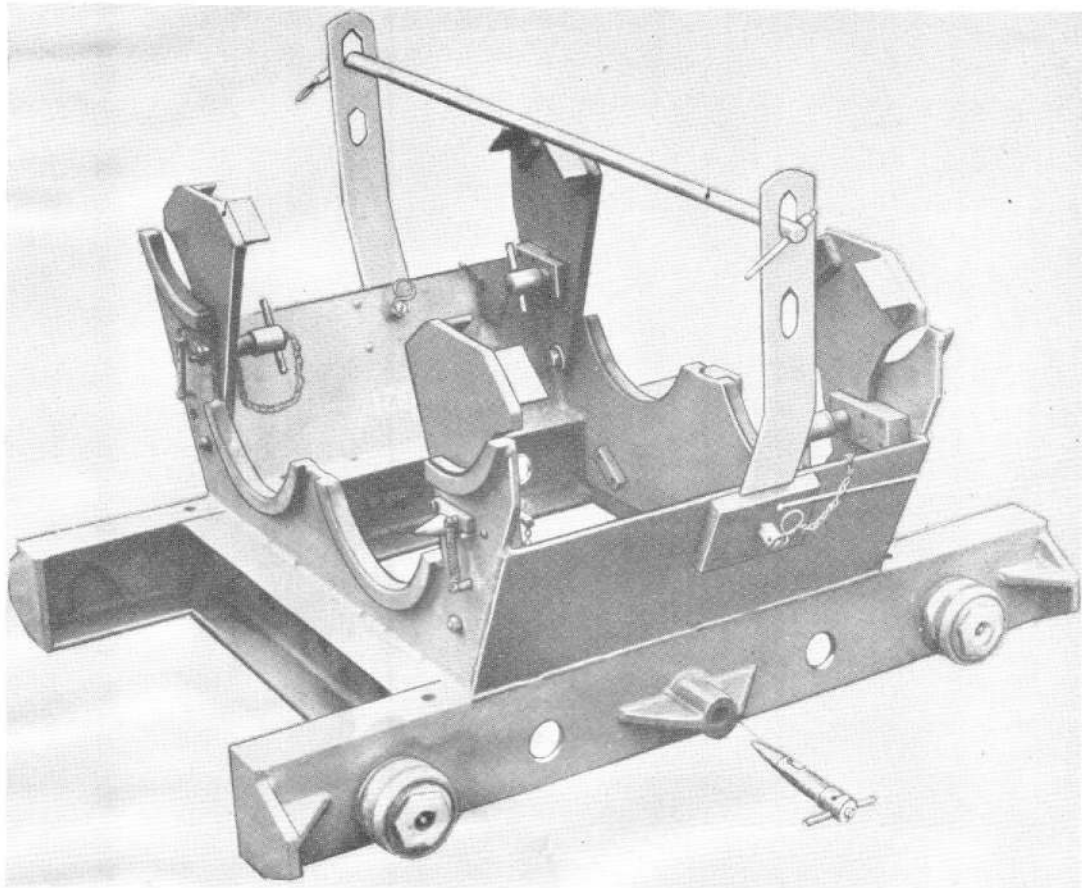

A.P. Reference 1664D (2nd Edn.), Vol. 1, Part 1, Sect. 1, Chap. 14

Ref. No. 26FZ/95525

Classification 2

Overall dimensions

Length 2 ft. 9½ in. **Width** 2 ft. 9 in. **Height** 1 ft. 10 in.

Weight 174 lb.

Brief description This cradle is normally mounted on the Canberra converted Type F bomb trolley and is used for the transportation of five 8 in. photoflash stores during missile preparation, the multi-store carrier No. 1 Mk. 2 and five 8 in. photoflash stores during Canberra aircraft loading and off-loading, and for supporting the multi-store carrier No. 1 Mk. 2 during servicing operations. The cradle is a steel plate welded structure with a channel-section base. The cradle is supported in the channel rails of the converted bomb trolley by four rollers and is located in its position on the trolley by a retaining pin. The cradle end plates are shaped and padded to form supports for the stores, and four hinged plates can be located in their raised positions to support the multi-store carrier. Two metal security straps and a securing rod are provided for securing the stores and carrier to the cradle.

RESTRICTED

ITEM 59

JACK, HOISTING, BOMB CARRIER—SHACKLETON Mk. 3

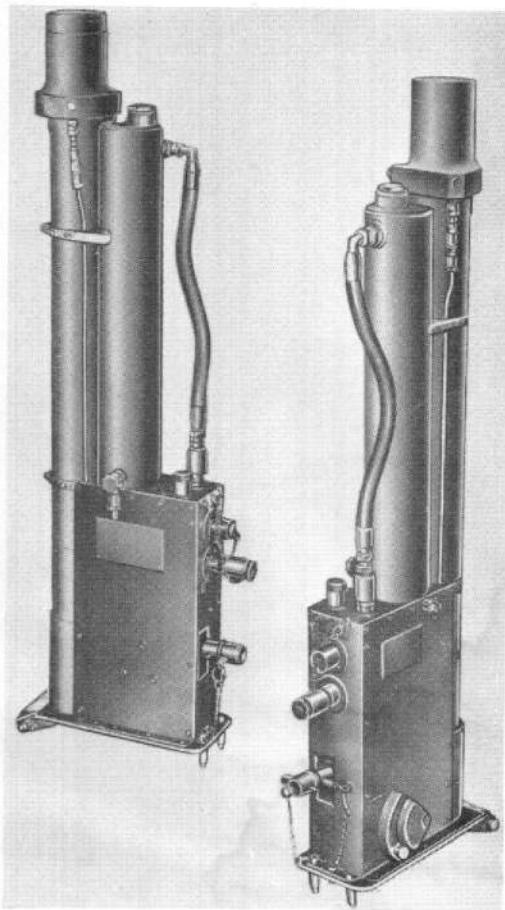

A.P. Reference 1664D (2nd Edn.), Vol. 1, Part 1, Sect. 2, Chap. 14

Ref. No. 26FP/384

Classification I

Overall dimensions

Length (retracted) 3 ft. 9 $\frac{3}{4}$ in. **Diameter of cylinder** 3 $\frac{1}{4}$ in.

Weight (empty) 91 $\frac{1}{2}$ lb.

Brief description Two of these two-stage hydraulic jacks are used for raising loaded bomb carriers from a ground trolley to the height necessary for their attachment to the suspension points beneath the Shackleton Mk. 3 aircraft. Each jack incorporates a cylindrical fluid reservoir and a lever-operated hand pump, and has a hydraulic lift of 61 $\frac{3}{4}$ inches. The jacks can be operated also from a hydraulic power pack and are fitted with self-sealing couplings for connecting the power pack hoses. The jack has a lifting capacity of 4980 lb. and a maximum working pressure of 3000 lb. per sq. in.

ITEM 60

PROJECTOR, ALIGNMENT

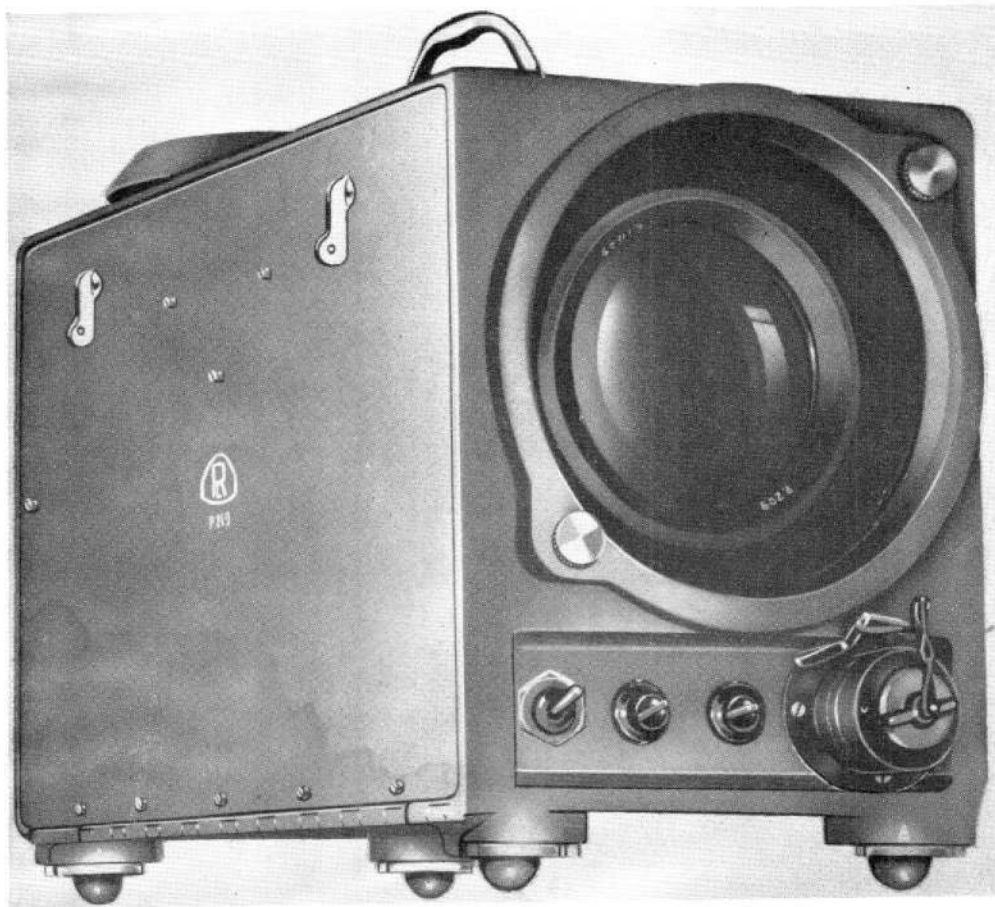

A.P. Reference 4483A, Vol. I, Part I, Sect. I, Chap. I4

Ref. No. 7R/786

Classification 2

Overall dimensions

Length 1 ft. $3\frac{3}{4}$ in. **Width** 7 in. **Height** 10 in.

Weight 25 lb.

Brief description This alignment projector is used to facilitate the harmonization of weapons and weapon systems in certain aircraft. The projector can be fitted to mounting points on the aircraft, and projects an alignment diagram on to a screen or wall. The screen, or white rectangle on the wall, should measure approximately 10 ft. x 7 ft. 6 in., and be positioned at a distance of 1000 inches measured from the forward mounting of the lower guns. The main components of the projector are the lamphouse, slide carrier, lens unit, and slides which determine the alignment pattern projected on to the screen; a 3-pole plug and socket on the front is for connecting an a.c. supply. The projector is used in conjunction with a Type MRG101 choke (7R/795) which has eight tapings to suit current supplies of between 190 and 260 volts, a.c., 50 cycles.

~~RESTRICTED~~

ITEM 61

INSTRUMENT, GUN ALIGNING (LIGHTNING)

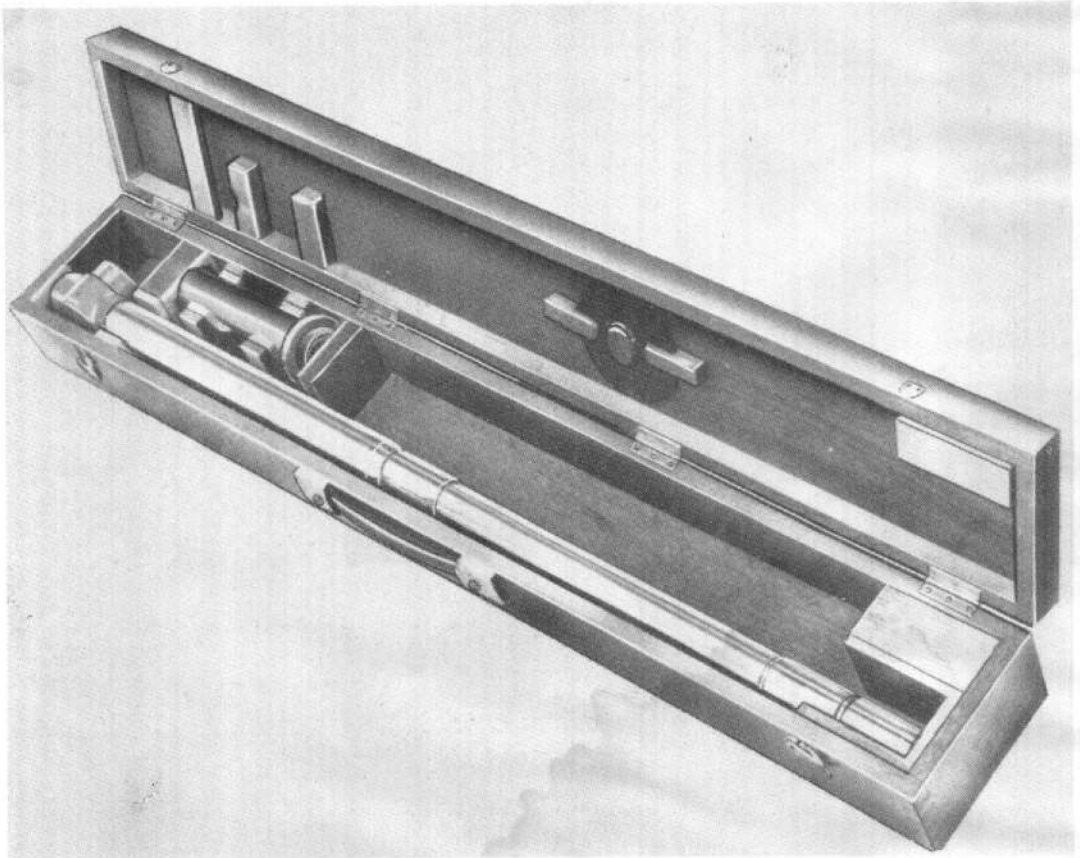

A.P. Reference 4483A, Vol. I, Part I, Sect. I, Chap. 15

Ref. No. 7R/754

Classification 2

Overall dimensions (*Transit case*)

Length 2 ft. 9 in. **Width** $3\frac{3}{4}$ in. **Height** $3\frac{3}{4}$ in.

Weight (*cased*) 17 lb.

Brief description This instrument is used to align aircraft 30 mm. Aden guns with an aiming mark when the standard instrument (7R/292) cannot be used. The instrument is supplied in a wooden transit case and consists of a steel barrel rod, an optical head, a flange and an eyepiece, which can be assembled to form a composite unit. The optical head contains a system of lenses, a graticule and a prism. When the instrument is being used, the barrel rod is inserted in the gun barrel, and the operator looks through the eyepiece and adjusts the gun until the aiming mark is seen in the centre of the graticule; the gun is then locked in this position. An expander in the end of the barrel rod can be adjusted to ensure that the rod is a good fit in the gun barrel.

ITEM 62

CHAMBER, VACUUM TESTING, Mk. 2

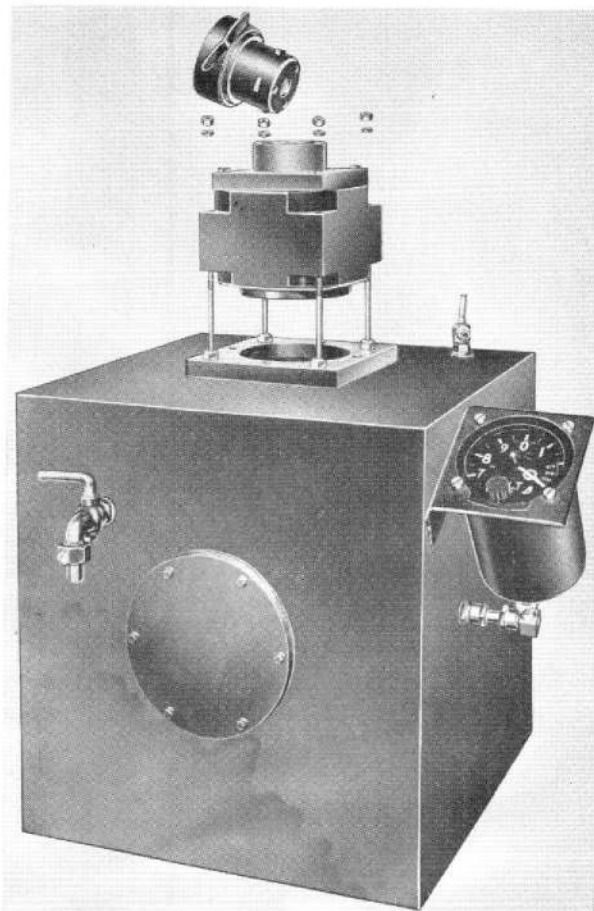

A.P. Reference 4483A, Vol. 1, Part 1, Sect. 3, Chap. 2

Ref. No. 7B/1833

Classification 2

Overall dimensions (approx.)

Length 1 ft. 3 in. Width 1 ft. 4 in. Height 1 ft. 5 in.

Weight

Brief description This chamber is used to test the air sealing devices in the $1\frac{1}{2}$ in., Mk. 1 and Mk. 2, pressure cabin pistols, and in the Mk. 2 mounting. When connected to an air suction line, the chamber will subject the store being tested to the same differential pressure conditions encountered during high altitude flight. A Mk. 14C(P)* aircraft altimeter is fitted to a bracket on the side of the chamber and registers depression within the chamber in terms of height in feet above sea level. The chamber consists of a rectangular $\frac{1}{4}$ in. steel plate box of one cubic foot capacity. Provision is made on the top of the chamber for securing a mounting adapter and the pistol mounting, or for securing the Mk. 2 mounting.

~~RESTRICTED~~

ITEM 63

TESTER, CIRCUIT, FOR 1.75 in. PHOTOFLASH DISCHARGER

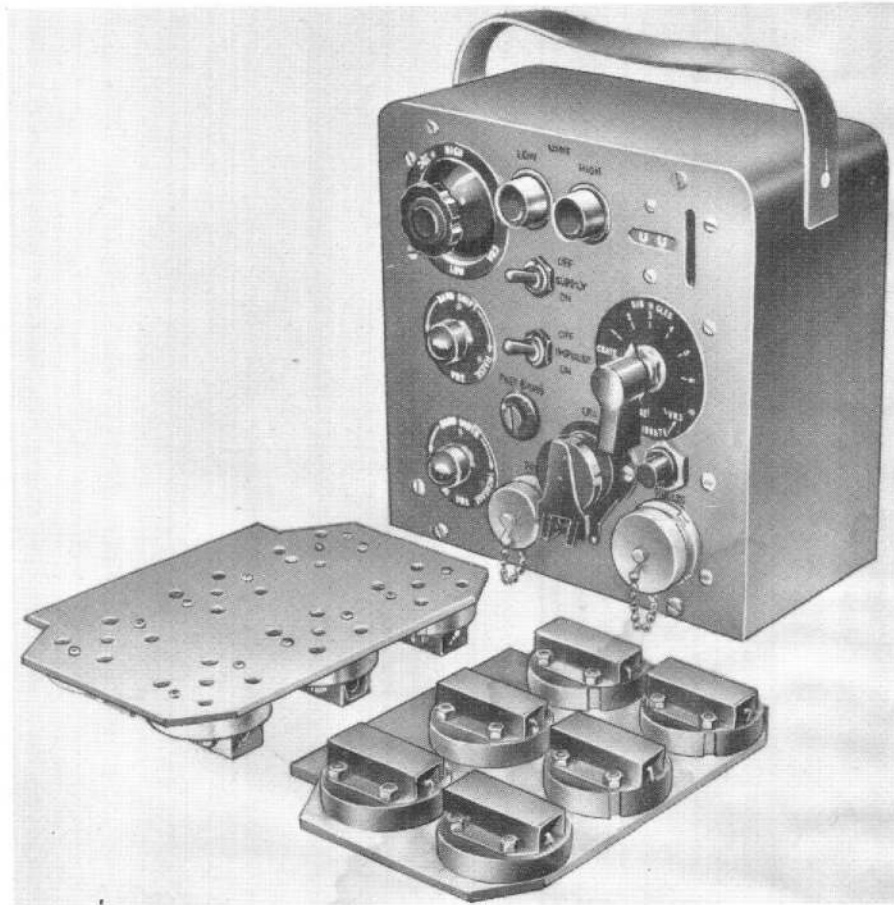

A.P. Reference 4483A, Vol. 1, Part 1, Sect. 3, Chap. 3

Ref. No. 5G/3226

Classification I

Overall dimensions

Length $7\frac{3}{4}$ in. **Width** $3\frac{3}{4}$ in. **Height** 7 in.

Weight $6\frac{1}{4}$ lb.

Brief description This impulse test set is used to test the electric firing circuits in a 1.75 in. photoflash discharger crate fitted with modified pyrotechnic distributors Type A Mk. 1 (5D/1772), and also the circuits in individual 1.75 in. photoflash dischargers. It embodies an electrical resistance measuring bridge which indicates if the resistance in the firing circuit being tested is outside the satisfactory limits. Power for operating the tester is provided by a 24/28 volts, d.c., supply which is plugged-in to a 2-pole socket. Included in the test equipment is a discharger contact plate (5G/3227) and a contact plate tester (5G/3228); top and bottom views of the contact plate are shown in the illustration above. The contact plate is necessary when testing individual dischargers. The contact plate tester is used to check the circuitry and the resistances in the contact plate.

ITEM 64

TESTER, BOMB CARRIER, Mk. I

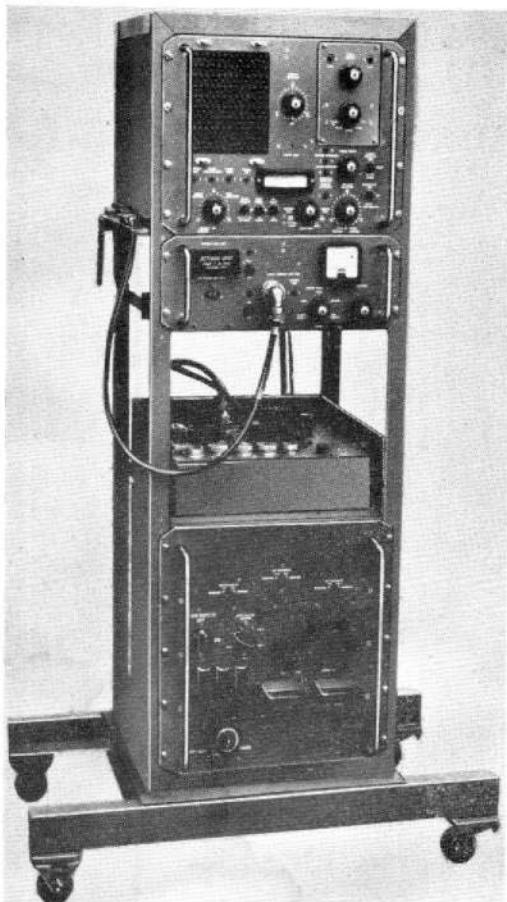

A.P. Reference 4483A, Vol. I, Part I, Sect. 4, Chap. 6

Ref. No. 5G/2923

Classification I

Overall dimensions

Length 1 ft. 11 in. **Width** 3 ft. 4 in. **Height** 5 ft. 5 in.

Weight 318 lb.

Brief description This mobile bomb carrier tester is used for checking the operation of bomb and photoflash carriers, and certain associated components, during servicing or before loading. It will test conventional carriers applicable to Vulcan, Victor and Valiant aircraft, and bomb and photoflash carriers applicable to Canberra aircraft. The tester consists of three main units, each fronted by a panel. The units include a main test panel, secondary test panel and a power pack, and are mounted in an angle-section steel rack mounted on four castor wheels; the units are linked to each other by plug and socket connectors. A test box also is supplied with each tester and is used to check the tester before actual tests on carriers. The power pack is a self-contained unit employing metal rectifiers and carbon pile voltage regulation operated from a 400/440 volts, a.c., 50-cycle, 3-phase mains supply. Three d.c. output voltages are available; 22 volts or 28 volts regulated up to 5 amps., capable of peaks up to 60 amps., and a separate 24 volts supply.

RESTRICTED

ITEM 65

TESTER FOR No. 3 Mk. 3 E.M. RELEASE UNIT

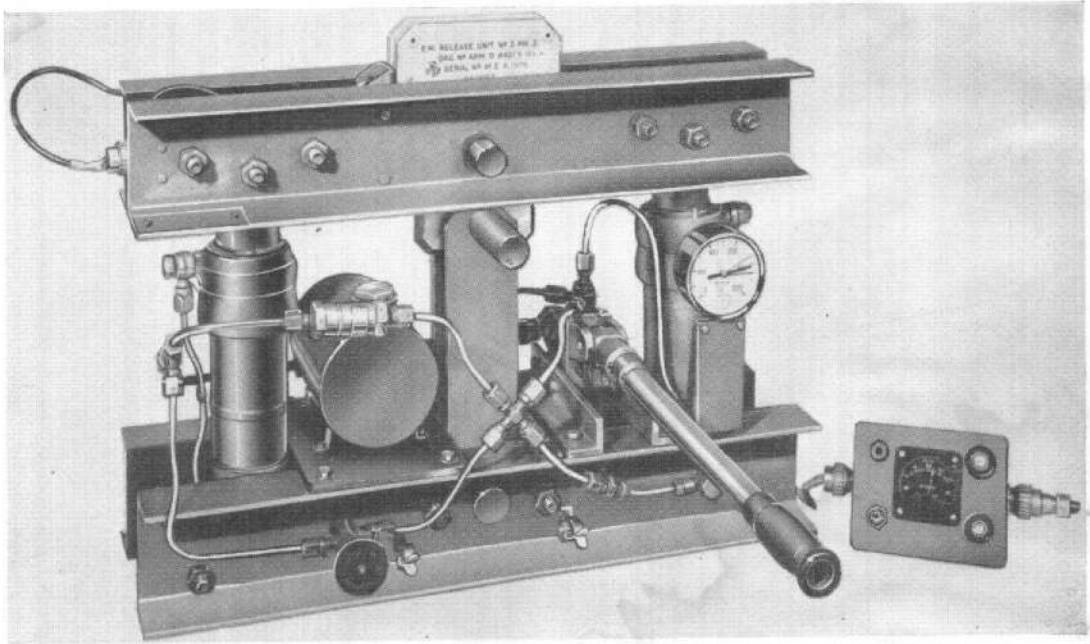

A.P. Reference 4483A, Vol. 1, Part 1, Sect. 4, Chap. 8

Ref. No. 11A/4514

Classification I

Overall dimensions

Length 2 ft. 6 in. **Width** 1 ft. 2 in. **Height** 1 ft. 9 in.

Weight 150 lb.

Brief description This hydraulic rig is used for testing No. 3 Mk. 3 E.M. release units with a proving load of over 10,000 lb. and for testing their efficient operation in the release of that load. The rig houses the release unit and subjects it to a load imposed hydraulically by two jacks operated by a hand pump, and supplied with fluid from a small reservoir. A pulse unit is mounted in the rig and is connected between an 18 volt d.c. external power supply and the release unit under test for testing the cocking circuit and for transmitting the required electrical pulse to operate the release unit. The two jacks are mounted between top and bottom beams of steel channel-section construction. The release unit is mounted in the top beam and is connected by an anchor pin to two tension plates mounted in the bottom beam, the load being applied to the release unit when the jacks are extended by operating the pump. The normal working pressure of the jacks is 1600 lb. per sq. in. and is indicated on a pressure gauge.

BOMB LOADING EQUIPMENT (Valiant 5-store carrier)

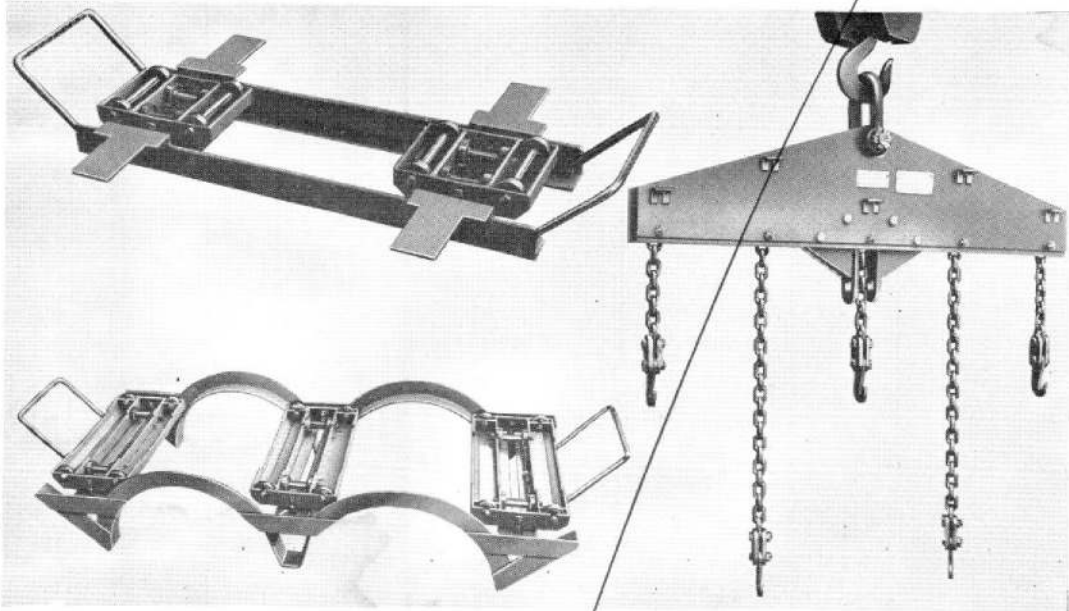

A.P. Reference 1664D (2nd Edn.), Vol. 1, Part 1, Sect. 2, Chap. 15

Ref. No. 26SR/95542 (Bottom loading assister)
 26SR/95543 (Top loading assister)
 26SR/95541 (Bomb loading beam)

Classification 2

Overall dimensions and weights

	Length	Width	Height	Weight
Bottom loading assister	39 in.	19 in.	6 in.	36 lb.
Top loading assister	58 in.	19 in.	12 in.	84 lb.
Bomb loading beam	45 in.	7 in.	18 in.	126 lb.

Brief description This equipment is used to facilitate the positioning of five 1000 lb. bombs for attachment to the Valiant 5-store carrier, and consists of a double carriage bottom loading assister, triple carriage top loading assister and a five-chain sling bomb loading beam. The equipment is used in conjunction with the 5 x 1000 lb. store cradle mounted on the standard airfield bomb transporter (ITEM 1). When in use, the bottom loading assister rests in the base of the store cradle to receive two bombs, the top loading assister rests across the two bombs already in position to receive three bombs, and the bomb loading beam, in addition to lifting the bombs into position, is used for lifting the Valiant 5-store carrier into position over the bombs.

RESTRICTED

BOMB LOADING EQUIPMENT (Vulcan 7-store carrier)

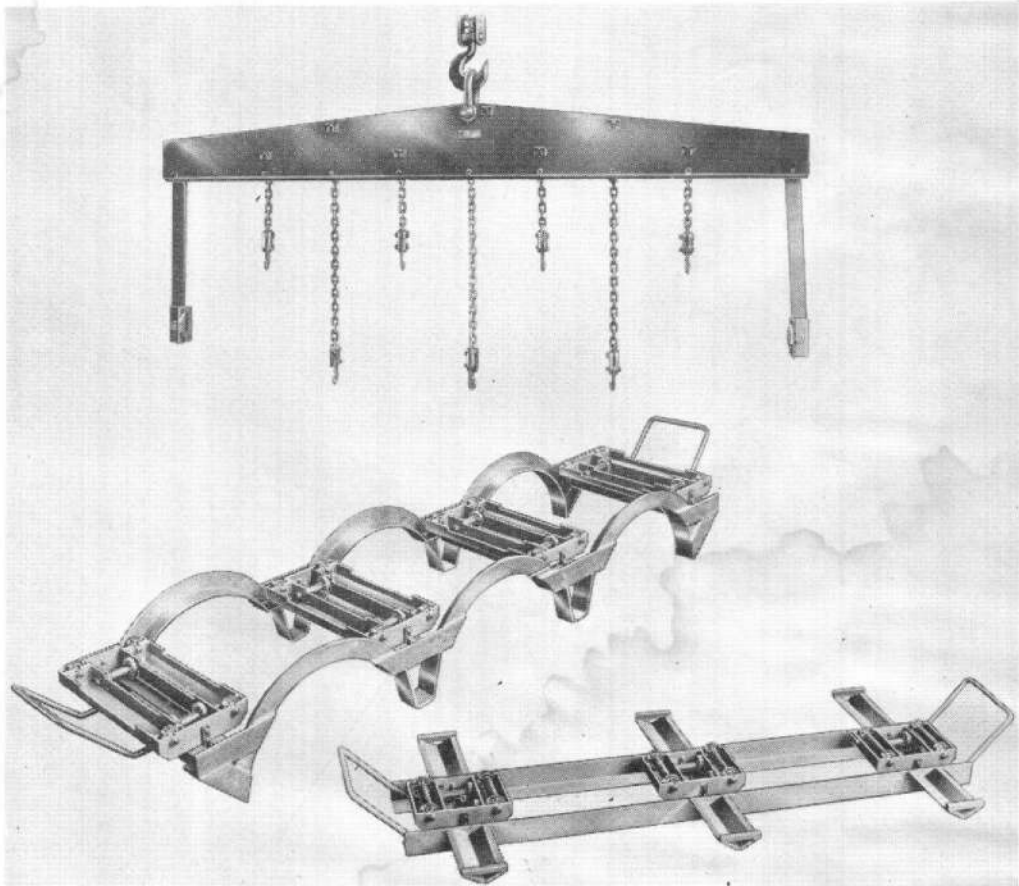

A.P. Reference 1664D (2nd Edn.), Vol. 1, Part 1, Sect. 2, Chap. 16

Ref. No. 26DC/95369 (Bottom loading assister)
26DC/95368 (Top loading assister)
26DC/95367 (Hoisting beam)

Classification 2

Overall dimensions and weights

	Length	Width	Height	Weight
Bottom loading assister	61 in.	24 in.	7 in.	46 lb.
Top loading assister	82 in.	20 in.	10 in.	125 lb.
Hoisting beam	98 in.	9 in.	18 in.	279 lb.

Brief description This equipment is used to facilitate the positioning of seven 1000 lb. bombs for attachment to the Vulcan 7-store carrier, and consists of a three-way bottom loading assister, four-way top loading assister and a seven-way bomb and carrier hoisting beam. The equipment is used in conjunction with the 7 x 1000 lb. store cradle mounted on the standard airfield bomb transporter (ITEM 1). When in use, the bottom loading assister rests in the base of the store cradle to receive three bombs, the top loading assister rests across the three bombs already in position to receive four bombs, and the hoisting beam is used to lift the bombs and also to lift the Vulcan 7-store bomb carrier, either with or without its bomb load.

ADEN GUN ELECTRICAL TEST EQUIPMENT

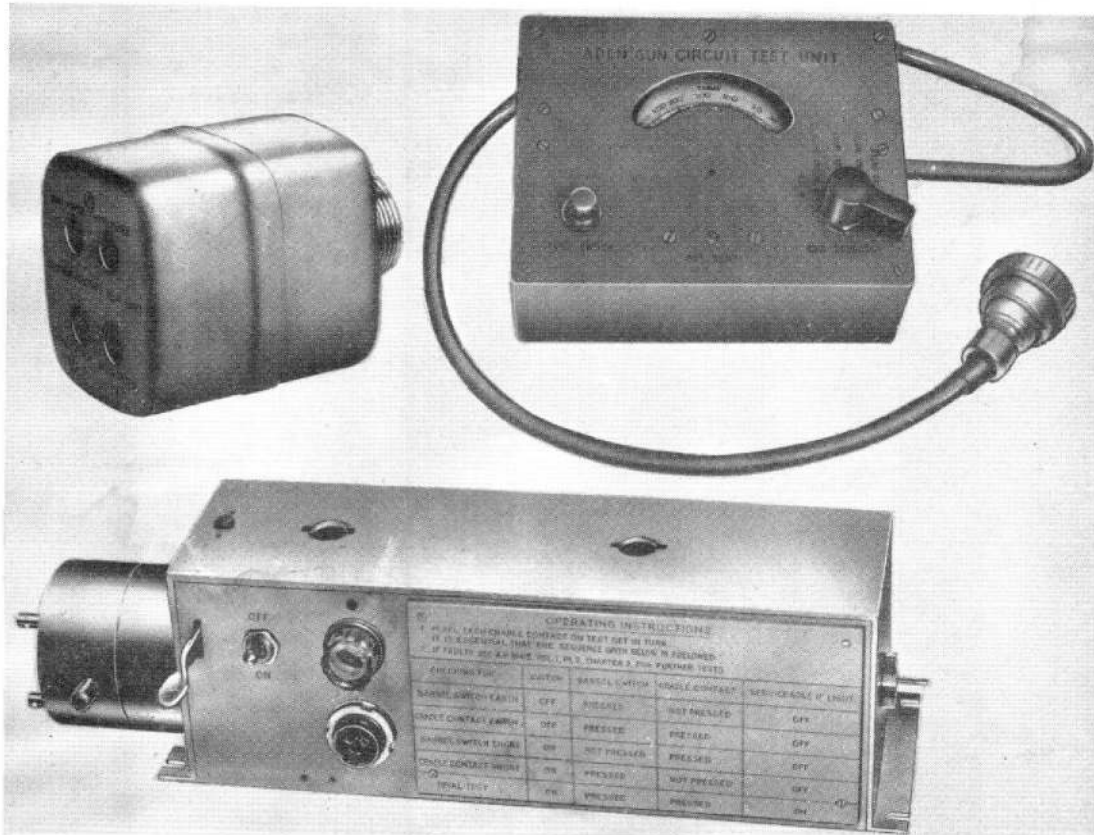

A.P. Reference 4483A, Vol. I, Part I, Sect. I, Chap. 13

Ref. No. 7R/544 (Aircraft test unit)
 7R/541 (Circuit test unit)
 7R/543 (Electrics test unit)

Classification I

Overall dimensions

	Length	Width	Height
Aircraft test unit	3½ in.	2½ in.	2½ in.
Circuit test unit	4½ in.	5⅞ in.	2⅛ in.
Electrics test unit	14½ in.	3⅞ in.	5 in.

Brief description This test equipment consists of three separate items, the Aden gun aircraft test unit, the circuit test unit and the electrics test unit. The aircraft test unit is used to test the gun firing circuit in the aircraft and is provided with an adapter lead (7R/545) for use when the installation of the guns to be tested is not of the package type. The Aden gun circuit test unit is used to test the gun circuits of a loaded gun package and is also provided with an adapter lead (7R/542) for use when the gun installation is of the non-package type. The Aden gun electrics test unit is used to test the serviceability of the electric firing unit and the cradle contacts of the gun.

RESTRICTED

ITEM 69

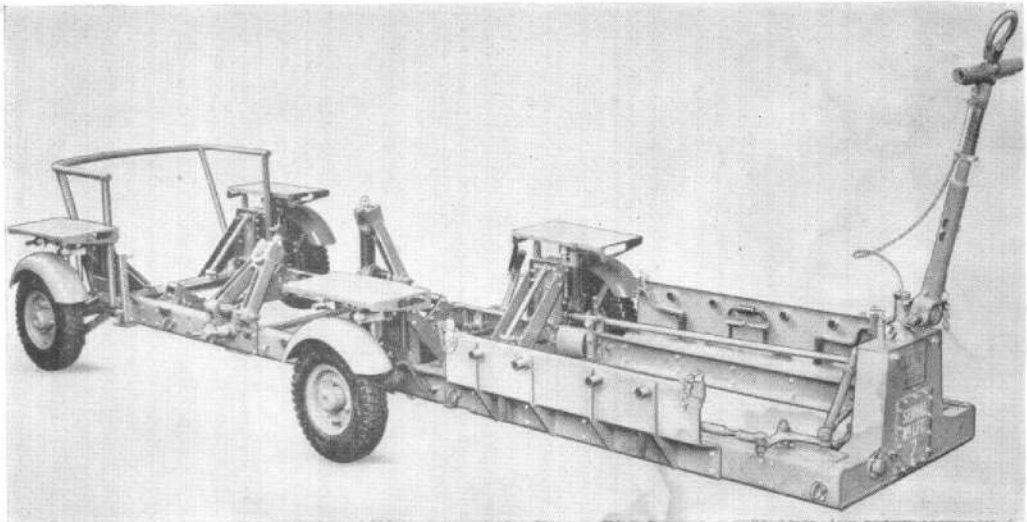
TROLLEYS, BOMB, TYPE J, Mk. 1 and 2

A.P. Reference 1664D (2nd Edn.), Vol. 1, Part 1, Sect. 1, Chap. 15

Ref. No. 76R/219 (Mk. 1)
76R/235 (Mk. 2)

Classification 1

Overall dimensions

Length 14 ft. 2 in. Width 4 ft. 10 in. Height (max.) 2 ft. 6 in.

Weight 860 lb.

Brief description These bomb trolleys are used for transporting and as an aid in the loading and unloading of a 2000 lb. store. Each trolley consists of a channel-section chassis frame mounted on four pneumatic-tired wheels; the two rear wheels are positioned half-way along the chassis to shorten the wheel base at the front end where the main load is supported. A tow-bar, which also operates the steering gear, is fitted to the rear end of the trolley and carries a handle for operating hydraulic brakes on all four wheels; the front wheel brakes can also be operated mechanically. Four screw jacks are fitted adjacent to the wheels for lowering and raising the chassis to facilitate the manoeuvring of the trolley under an aircraft, and to assist when loading a store. Two hinged trunnion brackets are mounted one on each side member to steady the store on the trolley, the store being mounted on two roller beams on the chassis frame. A guard rail at the front end of the chassis protects the nose of the store.

RESTRICTED

ITEM 70

TROLLEY, FORK LIFT, "SHERPA" TYPE, Mk. 2



A.P. Reference

Ref. No. 4D/2355

Classification 2

Overall dimensions

Length (incl. forks) 4 ft. 6 in.

Width 2 ft. 5½ in.

Height 5 ft. 10 in.

Weight 225 lb.

Brief description This trolley is used for the mechanical lifting and movement of bomb carriers weighing up to approximately 450 lb. in confined spaces such as storage areas and armament servicing bays. The trolley consists of a tubular steel chassis on the front of which is mounted a steel fabricated carriage fitted with two 22 in. long fork arms. The carriage runs on rollers and can be raised and lowered by a hydraulic jack to which it is attached by a roller chain. The jack is operated by a hand lever, with a foot assistance attachment for use when lifting the heavier loads. The forks can be lowered to 3½ in. from the ground and the height of lift is 4 ft. 11 in.; the lift per stroke of the lever is 1·2 in. The chassis is mounted on two cushion rubber-tyred main wheels and has two jockey wheels to provide four-wheeled support for the trolley when moving equipment; handles are fitted to a cross-member at the end of the chassis to facilitate manoeuvring. Forward extensions fitted with small rollers support the trolley when in the vertical position.

~~RESTRICTED~~

ITEM 71

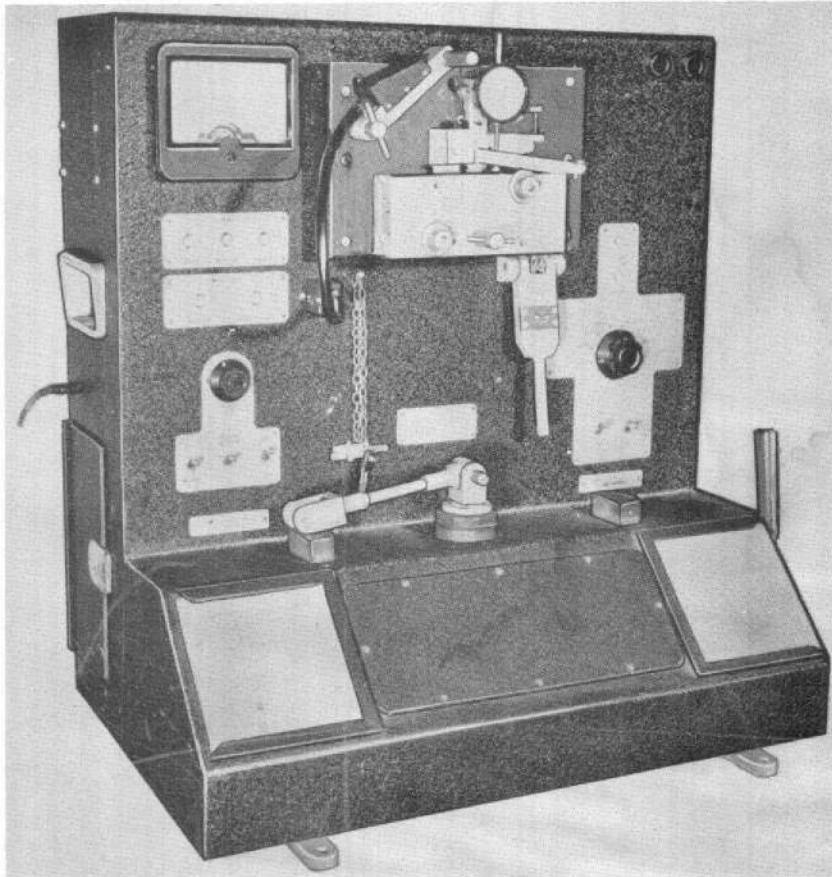
TESTER, BOMB RELEASE UNITS

A.P. Reference 4483A, Vol. 1, Part 1, Sect. 4, Chap. 10

Ref. No. 11A/4766

Classification 2

Overall dimensions

Length 2 ft. 5 in.

Width 1 ft. 9½ in.

Height 2 ft. 5 in.

Weight 112 lb.

Brief description This equipment is used for testing bomb release units and their housings, and provision is made for imposing a physical load of approximately 20 lb. on a release unit under test. The tester operates electrically from a 28/30 volts d.c. supply provided either by batteries or a suitable mains converter; current consumption is approximately 5 amp. The tester consists of a sheetmetal casing containing a pulse unit, loading mechanism, and the electrical equipment including a voltmeter, selector switches, indicating lamps, shorting plugs and wiring. A test housing for each type of release unit is provided, the housing being attached to a vertical mounting platform on the front on the casing. A unit under test is connected by a shackle to the loading mechanism. The illustration above shows the No. 1 test housing secured to the mounting platform, ready to accept a release unit.

RESTRICTED

ITEM 72

TROLLEY, COMPRESSOR, AIR, TYPE L, Mk. 2 and 2A

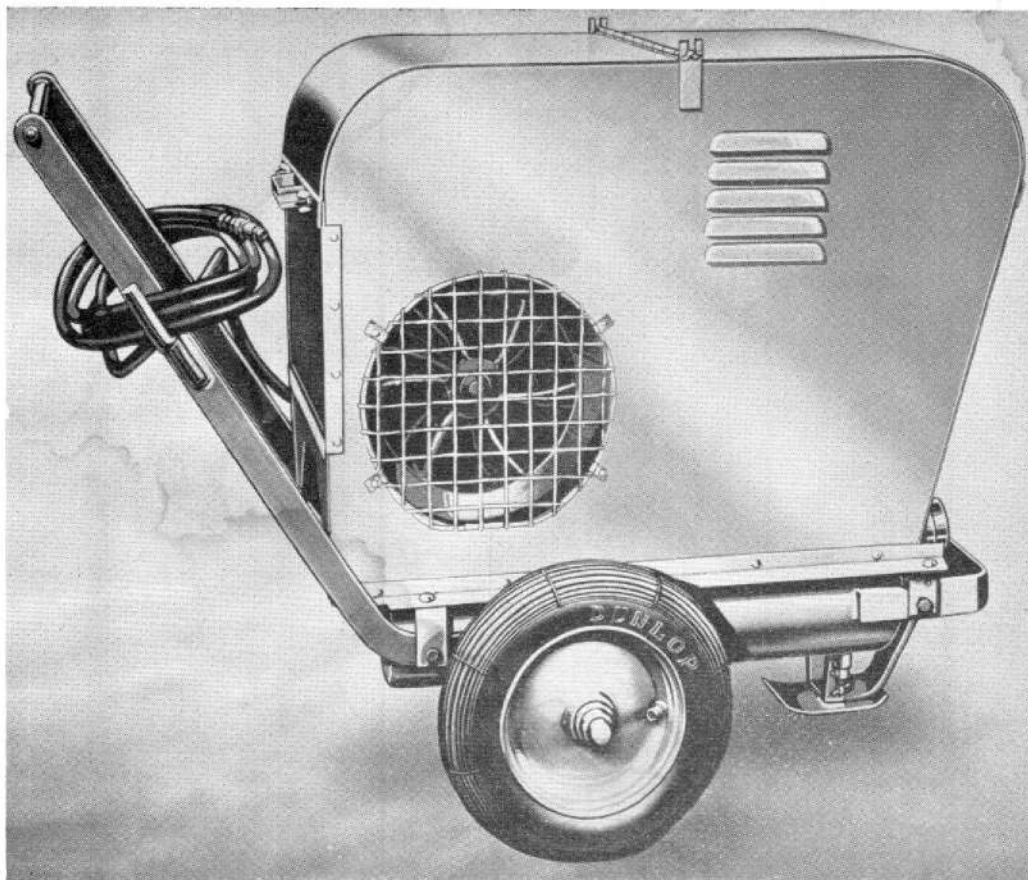

A.P. Reference 2306L

Ref. No. 4F/1693, 1783

Classification 1

Overall dimensions

Length (less handle) 2 ft. 8 in.

Width 2 ft. 6 in.

Height 3 ft. 0 in.

Weight 3 cwt. 12 lb.

Brief description These trolleys are used in armament servicing bays for pressurizing the Mk. 30 torpedoes during tests. Each trolley consists of a two-wheeled chassis carrying a 2-stage air compressor driven by a Mk. 25 Villiers gasoline engine. The compressor has a delivery capacity of 4 cu. ft. of free air per minute and a maximum working pressure of 450 lb. per sq. in. at a running speed of 1000 r.p.m. An A.I.D. Type 2A.S.6 compressor is fitted to the Mk. 2 trolley and a Bristol Duplex Type K compressor is fitted to the Mk. 2A trolley; the trolleys are similar in all other respects. Each trolley is fitted with a louvered cowling for weather protection.

RESTRICTED

ITEM 73

TROLLEY, BOMB, TYPE L

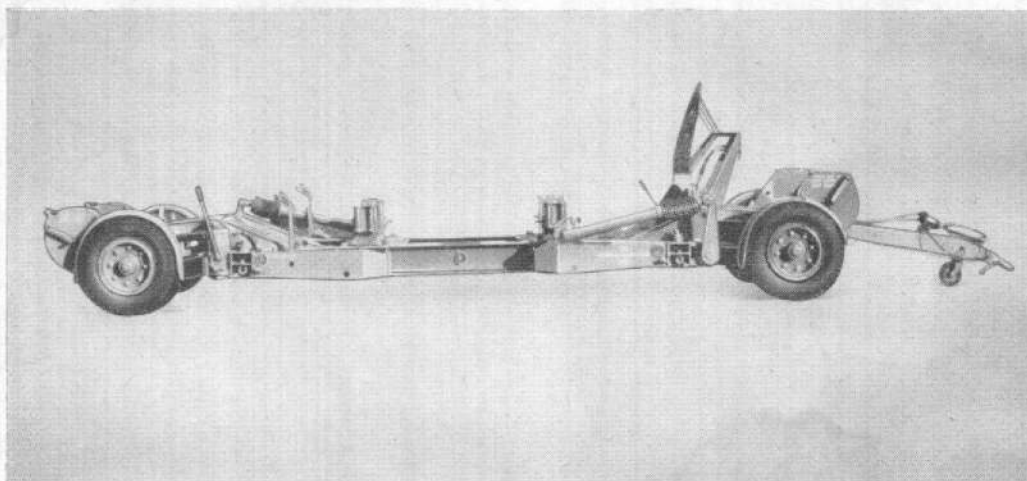

A.P. Reference 1664D (2nd Edn.)

Ref. No. 76R/371

Classification 1

Overall dimensions

Length 26 ft. 4 in.

Width 6 ft. 11 in.

Height (max.) 5 ft. 8 in.

Weight 4 tons

Turning circle dia. 70 ft. 0 in.

Brief description The Type L bomb trolley is used for transporting the bomb, A/C, H.E. 7000 lb. H.C., at speeds up to 30 m.p.h. when being towed by a truck fitted with a two line air pressure braking system and 4-pin lighting socket. The trolley is used in association with the Vulcan and Victor aircraft, and incorporates a hydraulic jack operated suspension system for adjusting the height of the trolley frame for towing ($9\frac{1}{2}$ to 10 in. ground clearance), manoeuvring the trolley under an aircraft ($\frac{3}{4}$ in. ground clearance), and for off-loading a bomb (frame resting on the ground). When the trolley is used for Vulcan aircraft, two bomb cradles are mounted on adapters on the frame; when used for Victor aircraft the adapters are fixed directly to the frame. Hydraulic brakes operated by the two line air pressure system act on all four wheels; in addition, a hand-operated parking brake acts on the two rear wheels. The rear wheels are normally locked in the fore and aft position but can be unlocked and the rear wheel steering controlled by a tiller bar when manoeuvring the trolley by hand.

RESTRICTED

ITEM 74

TROLLEY, SERVICING, BOMB CARRIER, TYPE A

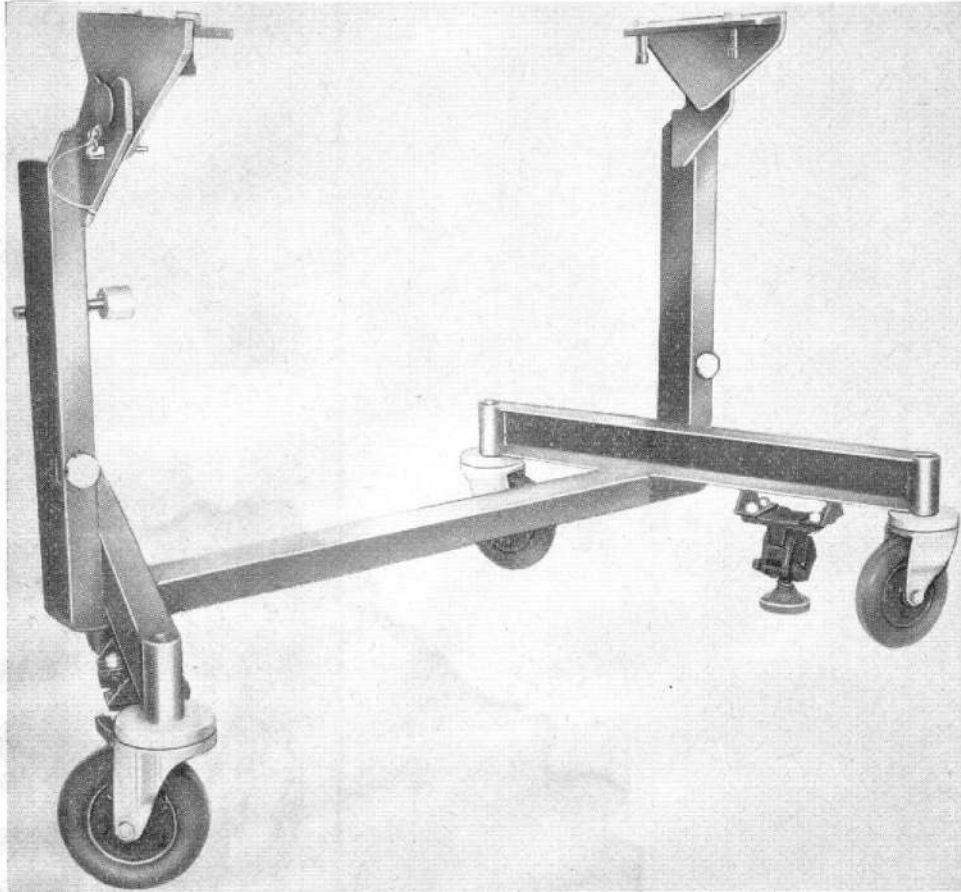

A.P. Reference 4483A, Vol. 1, Part 1, Sect. 4, Chap. 13

Ref. No. 4G/6234

Classification 2

Overall dimensions

Length 3 ft. 6 in.

Width 6 ft. 0 in.

Height 3 ft. 8 in.

Weight 250 lb.

Brief description This trolley is used for the movement and support of a bomb carrier during servicing operations. The carrier is bolted to two hinged support plates at the top of the trolley and can be turned through approximately 120 degrees and located by a pip pin in any one of three positions to provide access for servicing all parts of the carrier. The carriers which can be mounted on the trolley include the 1900 lb. Mk. 1, 6000 lb. No. 1 all marks, and the 2000 lb. No. 2 Mk. 1 carriers. The trolley is of welded steel channel section construction and is mounted on four 8 in. dia. fully castoring wheels fitted with solid rubber tyres. Two pedal-operated feet can be locked against the ground to prevent movement of the trolley.

RESTRICTED

ITEM 75

SAFETY FOLLOW-UP EQUIPMENT (S.A.B.T.)

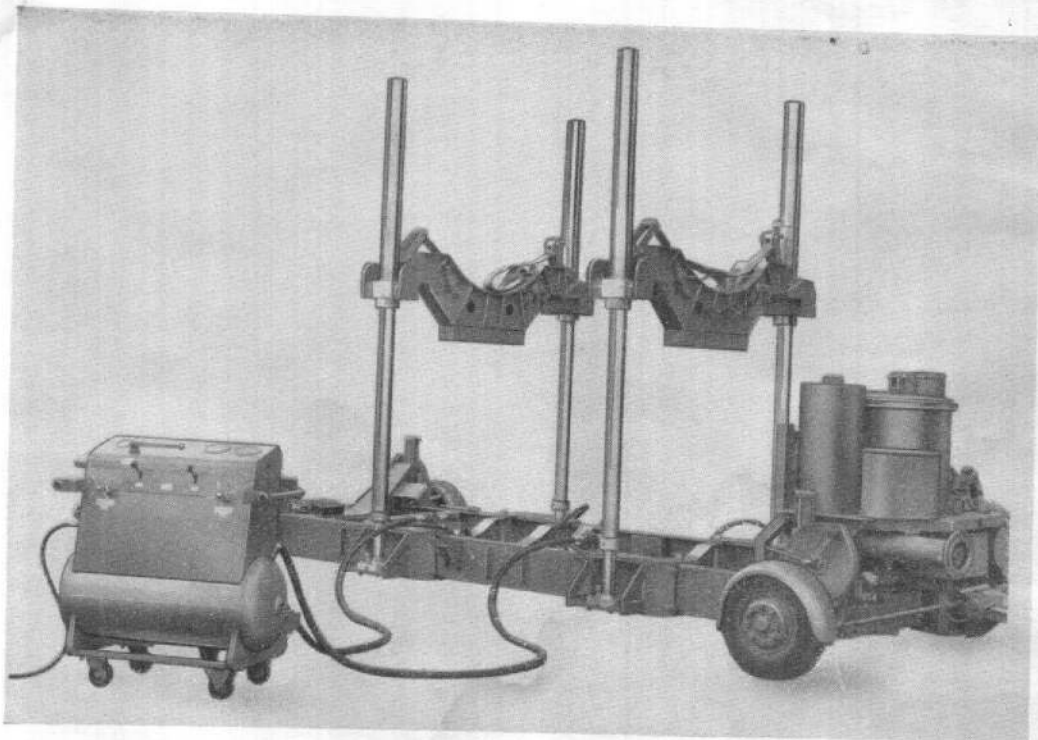

A.P. Reference 1664D (2nd Edn.), Vol. 1, Part 1, Sect. 2

Ref. No. 76R/356

Classification 2

Overall dimensions and weight

	Length	Width	Height	Weight
Jack units	—	—	12 ft. 7 in. (extended) 4 ft. 10 in. (retracted)	2272 lb.
Control console	3 ft. 3½ in.	2 ft. 5¼ in.	3 ft. 3¾ in.	512 lb. (dry)

Brief description This equipment is used in conjunction with the standard airfield bomb transporter (S.A.B.T.) (ITEM 1) during the loading or off-loading of heavy stores into or from the bomb bay of certain aircraft. It consists of two pairs of double-ram hydraulic jacks fixed to the transporter chassis side members and each pair of jacks carries a cradle which spans the chassis, under the store. Hydraulic pressure of 130 lb. per sq. in. is fed equally to the four jacks via a control console, operated by air pressure, to actuate the jacks and raise the cradles under the store. The jacks take no part in the actual hoisting or lowering of the store, but they ensure that the cradles follow up the store during hoisting, or precede the store during lowering, and will arrest and support the store should there be a failure in the hoisting, lowering or store suspension equipment. A non-return valve in the circuit to each pair of jacks provides a hydraulic lock to prevent retraction of the jacks until the appropriate valves on the console are operated.

~~RESTRICTED~~

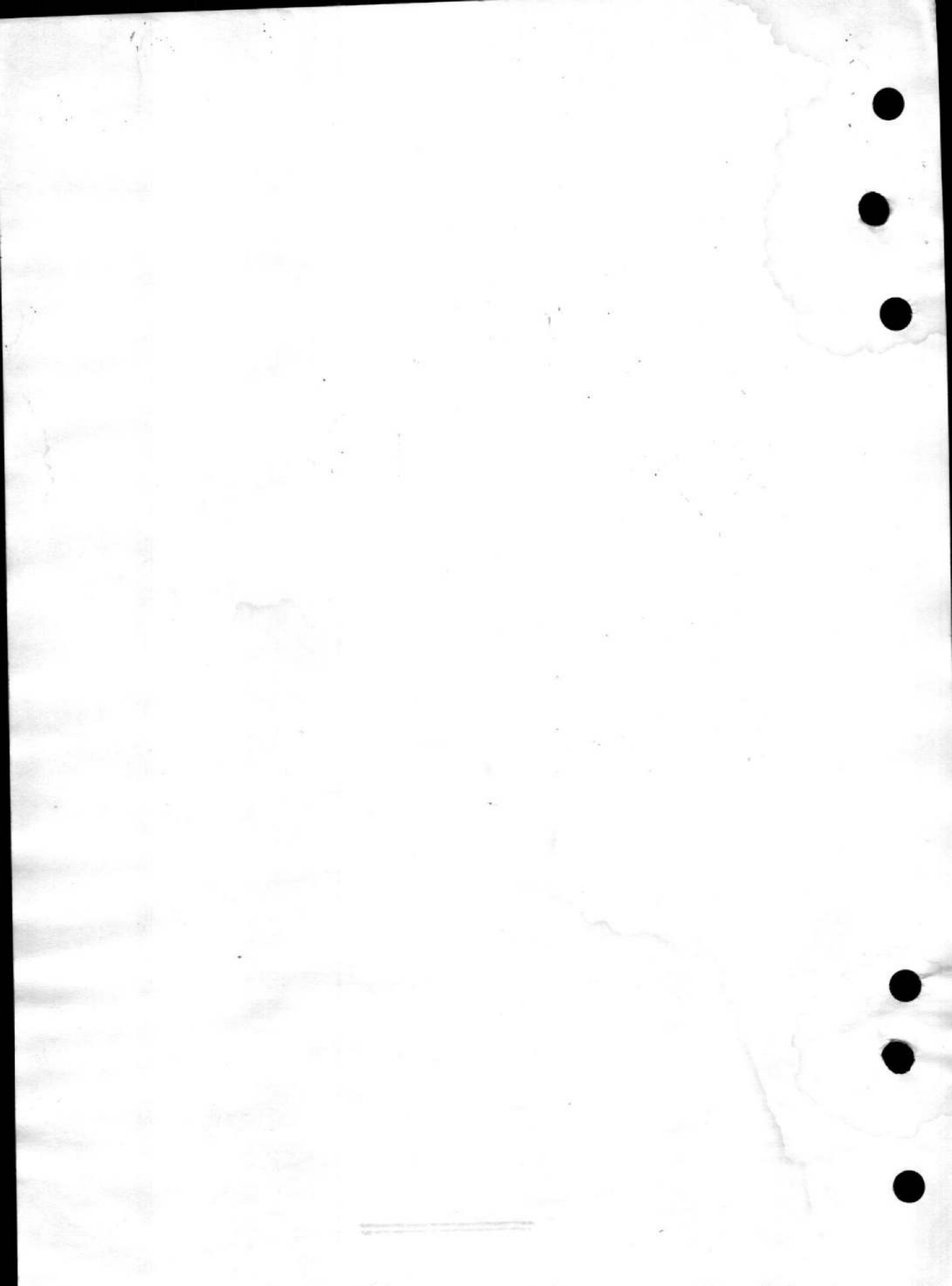

This file was downloaded
from the RTFM Library.

Link: www.scottbouch.com/rtfm

Please see site for usage terms,
and more aircraft documents.

