

**CHAPTER 1**

**GENERAL INFORMATION**

**R E S T R I C T E D**

## Chapter 1

GENERAL INFORMATION  
(Completely revised)  
List of Contents

|                                | Para. |                            | Para. |
|--------------------------------|-------|----------------------------|-------|
| Description ... ..             | 1     | Repair material ... ..     | 7     |
| Repairing the aircraft . . . . | 2     | Alternative material... .. | 7A    |
| Dismantling ... ..             | 3     | Replacement parts ... ..   | 8     |
| Dents, cracks or buckles ...   | 4     | Checking profiles ... ..   | 9     |
| Damaged rivet and bolt         |       | Treatment of repair        |       |
| holes ... ..                   | 4A    | material ... ..            | 10    |
| Bowed tubes ... ..             | 4B    | Rivet data ... ..          | 11    |
| Repair procedure ... ..        | 5     | Standard sections ... ..   | 12    |
| Elongated rivet holes .. . .   | 6     | Wear limits ... ..         | 13    |

## List of Illustrations

|                               | Fig. |                             | Fig. |
|-------------------------------|------|-----------------------------|------|
| Solid rivet data sheet .. . . | 1/1  | Pop rivet data sheet ... .. | 1/1B |
| Chobert rivet data sheet ...  | 1/1A | Standard sections ... ..    | 1/2  |

## Description

1. The Chipmunk is a two seater low wing cantilever monoplane generally of metal construction. It is powered with a Gipsy Major Mk.8 engine and is designed for use as a primary trainer. The two seats are arranged in tandem enclosed by wind screen and a single sliding canopy. The port and starboard main planes are secured to the fuselage at the main spar and leading edges. Slotted ailerons are fitted and hand operated flaps extend from the root fillets to the inboard ends of the ailerons. The alighting gear consists of a conventional two wheel cantilever non-retractable undercarriage with a fully castoring tail wheel. The single fin has a balanced rudder mounted wholly above the fuselage and the cantilever tailplane has balanced elevators.

## Repairing the aircraft

2. The information in the following chapters affords sufficient instruction for effecting minor repairs. Specific direction in effecting repairs to structures where special tools, jiggling or support of the aircraft may be necessary, will be found in Part 2.

## Dismantling

3. Before removing any part of the airframe, consideration should be given to the effect upon the structure generally of the proposed repair and proper support afforded to prevent distortion of the airframe. Where special tools are available these should always be used in the manner prescribed for the fitting or the removal of components. Components removed should be carefully cleaned but abrasives must be

RESTRICTED

avoided as the very thin skin used on the aircraft must be kept free from scratches.

#### Dents, cracks or buckles

4. In the event of inspection revealing a dent, score or buckle, a thorough inspection must be carried out for fine hair cracks. Buckles in the skin or other members must be dressed out and extreme care taken to ensure that cracks, however minor they appear to be, are not overlooked. If cracks are suspected and cannot be detected visually a suitable method of crack detection should be carried out. Cracks shall be eliminated by cutting out the affected area, allowing sufficient margin from the extremities of the cracks to ensure complete elimination, and the approved method of repair applied. Cracks in fairings or fillets may be arrested by drilling 1/8 in. dia. holes at the extremities of the cracks and applying a suitable repair.

#### Damaged rivet and bolt holes

4A. Damage in the form of drawn rivet or bolt holes, may be detected by the cracking or flaking of the surrounding paint film. A feeler gauge inserted under the riveted plates will determine whether the rivets have failed or stretched, leaving their heads intact.

#### Bowed tubes

4B. The limits of bowing in tubular members which can be considered negligible is 1 in 600. Tubes bowed to an extent not exceeding 1 in 15 need not be replaced if they can be straightened to an eccentricity of 1 in 600. If this is not possible or the tube develops cracks in straightening, they must be replaced.

#### Repair procedure

5. The damaged area should be carefully inspected to determine treatment. If a repair is decided upon the following procedure should be adopted:-

Remove all rivets from damaged area. This should not be done by cutting with a chisel otherwise elongated holes will occur. The head of a rivet should be carefully indented with a punch so that the head can be drilled off. The shank should be punched out. The light gauge of the material used on the aircraft makes extreme care essential during repairs.

#### Elongated rivet holes

6. Rivet holes which have become elongated should be drilled out for the next size larger rivet - a 1/8 in. dia. rivet originally fitted is replaced with a 5/32 in. dia. rivet. A check should however be made of rivets in the remainder of joint to ensure that oversize rivets had not been introduced by a previous repair, as stepping up rivets two sizes in certain locations would be dangerous.

#### Repair material

7. Materials required to carry out repairs to the airframe will be found listed in Table 1. Where the specified material is not available an approved material of at least equal strength may be used. D.T.D.610 may be substituted for D.T.D.546 provided a thicker gauge material is used to maintain equal strength, i.e. for D.T.D.546, 19 s.w.g. use D.T.D.610, 18 s.w.g. Attention is called to the use of thicker materials in Para.7A.

**RESTRICTED**

#### Alternative material

7A. Generally on the aircraft the gauges used for the skin are odd (19, 21, 23, etc.). Usually the odd gauge sheet is available for use in repairing damage to the skin, but when this is not so, the next gauge thicker material may be used provided that the area so treated does not exceed 3 feet square. Larger areas must be repaired with specified material. Material to Spec. D. T. D. 546 is used in certain locations and it should not be forgotten that this material requires special heat treatment before being cold worked. Where flanged repair parts are necessary alclad to Spec. D. T. D. 610 can be used one or two gauges thicker than the original D. T. D. 546 material, in order to obviate the need for special heat treatment.

#### Replacement parts

8. Damage will frequently call for a replacement of a damaged component. Ribs, formers or stringer sections may be required and not be readily available. To enable such components to be made up locally the gauge of the material with specification is shown on the pertinent illustrations and generally the design can be copied from the original part. Usually it is possible to straighten up a damaged member sufficiently to get the design accurately enough to copy from. The profile of a rib or fuselage former is important.

#### Checking profiles

9. It is assumed that damaged skin and the affected member have been cut away or removed. Slats should be laid from one end of the damage to the other. This should afford the lines of a fair profile to match the

existing contours. A plywood template should then be made and fitted into the structure and to the slats, due allowance being made for the skin, etc. If the stringers have been removed their location can be obtained by the use of strings stretched from one end of the damage to the other and the template marked off accordingly. The template can then be removed and the made up part checked from it.

#### Treatment of repair material

10. Material to D. T. D. 390 or D. T. D. 610 can sometimes be cold worked in its fully heat treated condition. When however the repair is such that material is likely to crack in working, the heat treatment laid down in A. P. 1464, Vol. 1 should be strictly followed. The special heat treatment necessary before working material to D. T. D. 546 must always be followed when using repair sheet to this specification. After all repairs protective treatment must be properly applied to the repaired area to match adjacent material or in accordance with A. P. 2662A or B.

#### Rivet data

11. Types of rivets used in construction and repair of this aircraft will be found illustrated in fig. 1/1, 1/1A and 1/1B. Where inaccessibility makes solid riveting impossible, blind rivets are specified for repairs. Rivets to be used are Monel metal pop rivets (fig. 1/1B) for parts thinner than 20 s. w. g. and Chobert rivets (fig. 1/1A) for 20 s. w. g. or thicker parts.

Shear pins need not be fitted in Chobert rivets unless this is specified in the relevant repair scheme,

**RESTRICTED**

Table 1 - continued

| Stores ref. number  | Material   | Part number   | Size   | Specification |
|---|--|---|--|---------------|
| 30B/1086<br>30B/  | Sheet metal -<br>continued<br>Alum. manganese<br>alloy                         |   | 20<br>25   | D.T.D.213     |
| 30A/547<br>30A/549  | Mild steel   |   | 20<br>22   | S.3           |
| 30A/2500<br>30A/2138  | Carbon steel   |   | 16<br>18   | D.T.D.124A    |
| 30A/  | Stainless steel  |   | 28   | D.T.D.171A    |
| 30A/  | Low tensile<br>stainless steel   |   | 28   | D.T.D.571     |
|   | STANDARD<br>SECTIONS:<br>Lipped zed<br>Angle<br>Top hat<br>Open angle<br>Angle | J516<br>J601<br>J602<br>J604<br>J617                                    |  | D.T.D.610     |
| 28Q/10852<br>28Q/11557<br>28Q/10407<br>28Q/10653<br>28Q/10449 | RIVETS:<br><br>Alum. alloy<br>mushroom hd.                                     | AS.2228/303<br>AS.2228/310<br>AS.2228/404<br>AS.2228/505<br>AS.2228/508 | 3/32in. dia.<br>3/32in. dia.<br>1/8 in. dia.<br>5/32in. dia.<br>5/32in. dia. | L.69          |
| 28Q/6683<br>28Q/6446  | Chobert,<br>light alloy  | TK.2.SNA<br>TK.3.SNA  | 1/8 in. dia.<br>1/8 in. dia.   |               |
| 28Q/7853  | Chobert, steel   | TK.3.SS   | 1/8 in. dia.   | D.T.D.720     |
| 28Q/6886<br>28Q/6887<br>28Q/6879                              | Chobert,<br>light alloy  | TL.3.SNA<br>TL.4.SNA<br>TL.3.CNA  | 5/32in. dia.<br>5/32in. dia.<br>5/32in. dia.                                 | L.69          |
| 28Q/8049  | Chobert, steel   | TL.3.SS   | 5/32in. dia.   | D.T.D.720     |
| 28Q/9417266<br>28Q/9417267                                    | Dome head pop<br>rivet<br>Dome head pop<br>rivet                               | AGS2050/419/BS<br>AGS2050/424/BS  | 1/8 in. dia.<br>1/8 in. dia.   | D.T.D.10      |

continued

**RESTRICTED**

Table 1 - continued

| Stores ref. number | Material                                      | Part number    | Size                    | Specification            |
|--------------------|---|----------------|-------------------------|--------------------------|
| 28Q/9417246        | Countersunk head pop rivet                    | AGS2051/424/BS | 1/8in. dia.             | D. T. D. 10              |
| 28Q/9417272        | Domehead pop rivet                            | AGS2050/524/BS | 5/32in. dia.            |                          |
| 28Q/9417251        | Countersunk head pop rivet                    | AGS2051/524/BS | 5/32in. dia.            |                          |
| 28Q/6755           | MISCELLANEOUS:<br>Shear pin,<br>Chobert rivet | L. 3. PD       | For 5/32in. dia. rivets | L. 64 or<br>D. T. D. 423 |
| 28S/6239           | Screw, Parker Kalon                           |                | No. 4x3/8 in.           |                          |
| 28H/7617           | Ferrule                                       | AGS934/GS      | 5/16in. dia.            |                          |
| 28R/6328           | Screwed rod                                   | AGS935/C       | 1.6in. long             |                          |
| 28D/9436920        | Bolt  | A25/IC         | 2 BA                    |                          |
| 28M/9403520        | Nut   | A27/CP         | 2 BA                    |                          |
| 26FY/10812         | Pin   | DHS94/6/90     | 3/16in. dia.            |                          |
|                    | Replacement Footwell                          | RC1FS105       |                         |                          |
| 32B/1147 & 614     | Fabric  |                |                         | D. T. D. 540             |
| 32B/751 to 758     | Serrated fabric tapes                         |                |                         | D. T. D. 540             |
| 32B/759            | Linen tape                                    |                |                         |                          |
| 32B/686            | Egyptian cotton tape                          |                |                         | D. T. D. 407             |
| 32B/1064           | Adhesive tape (acid free)                     |                |                         |                          |
| 32B/654            | Linen thread                                  |                | No. 40                  |                          |
| 34A/156            | Braided nylon cord                            |                | No. 3                   | D. T. D. 786             |
|                    | Drain washer                                  | DHS18.2        |                         |                          |
| 27H/1193           | Inspection frame, Woods type                  | AGS583         | 2in. opening            |                          |
| 33C/               | Cellulose acetate sheet                       |                | .03in. thick            |                          |
| 30C/               | Welding rod                                   |                |                         | BS1453                   |
| 33C/               | Welding flux                                  |                |                         |                          |
| 33C/1309           | Cement Tensol No. 3                           |                |                         | D. T. D. 900/            |
| 33C/9436930        | No. 6   |                |                         | 4142                     |
| 33C/               | Perspex sheet                                 |                | 0.1 or 3/32 in. thick   | D. T. D. 339             |

RESTRICTED

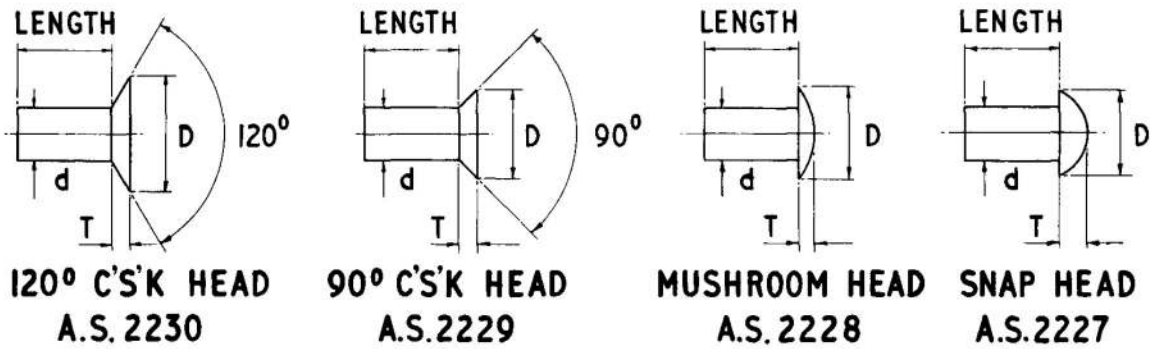

| DIMENSIONS OF RIVETS |                              |       |                             |       |                            |       |                        |      |
|----------------------|------------------------------|-------|-----------------------------|-------|----------------------------|-------|------------------------|------|
| DIA.<br>d            | 120° C'SK. HEAD<br>A.S. 2230 |       | 90° C'SK. HEAD<br>A.S. 2229 |       | MUSHROOM HEAD<br>A.S. 2228 |       | SNAP HEAD<br>A.S. 2227 |      |
|                      | D                            | T     | D                           | T     | D                          | T     | D                      | T    |
| 3/32                 | 0.193                        | 0.036 | 0.170                       | 0.041 | 0.21                       | 0.038 | 0.16                   | 0.06 |
|                      | 0.181                        | 0.030 | 0.158                       | 0.035 |                            |       |                        |      |
| 1/8                  | 0.256                        | 0.045 | 0.225                       | 0.053 | 0.28                       | 0.050 | 0.22                   | 0.08 |
|                      | 0.244                        | 0.039 | 0.213                       | 0.047 |                            |       |                        |      |
| 5/32                 | 0.318                        | 0.056 | 0.279                       | 0.065 | 0.35                       | 0.063 | 0.27                   | 0.09 |
|                      | 0.306                        | 0.050 | 0.267                       | 0.059 |                            |       |                        |      |
| 3/16                 | 0.381                        | 0.064 | 0.334                       | 0.077 | 0.42                       | 0.075 | 0.33                   | 0.11 |
|                      | 0.369                        | 0.058 | 0.322                       | 0.071 |                            |       |                        |      |

| LENGTH (PROUD OF PLATE) REQUIRED TO FORM HEAD |      |      |      |      |
|---|------|------|------|------|
| DIAMETER OF RIVET                             | 3/32 | 1/8  | 5/32 | 3/16 |
| ROUND HEAD                                    | 0.12 | 0.16 | 0.19 | 0.23 |
| C'SK HEAD                                     | 0.05 | 0.06 | 0.08 | 0.09 |

**METHOD OF CALLING UP RIVETS**

IN THE LENGTH OF RIVET TABLE THE LAST TWO FIGURES OF THE PART NUMBER DENOTE THE LENGTH OF THE RIVET IN 1/16ths. OF AN INCH

THE FIRST FIGURE DENOTES THE DIAMETER IN 1/32nds. OF AN INCH

EXAMPLE, PART No. A.S.2227/606  
A.S. 2227 = SNAP HEAD ALUM. ALLOY TO SPEC. L.69

6 = 6/32 OR 3/16 DIAMETER  
06 = 6/16 OR 3/8 LONG

| LENGTH OF RIVETS |              |     |      |      |
|------------------|--------------|-----|------|------|
| DIA. d           | 3/32         | 1/8 | 5/32 | 3/16 |
| LENGTH           | PART NUMBERS |     |      |      |
| 3/16             | 303          | 403 |      |      |
| 1/4              | 304          | 404 | 504  |      |
| 5/16             | 305          | 405 | 505  | 605  |
| 3/8              | 306          | 406 | 506  | 606  |
| 7/16             | 307          | 407 | 507  | 607  |
| 1/2              | 308          | 408 | 508  | 608  |

NUMBERS THIS SIDE OF THICK LINE DO NOT APPLY TO A.S. 2228, 2229 AND 2230

DIMENSIONS ARE IN INCHES

Fig.1/1. Solid rivet data sheet

**RESTRICTED**

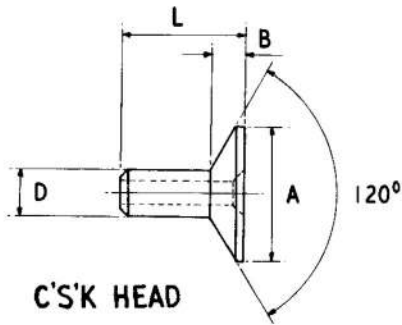

C'S'K HEAD

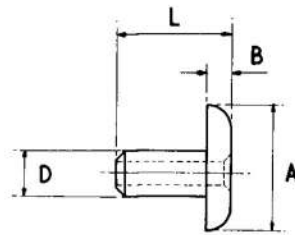

SNAP HEAD

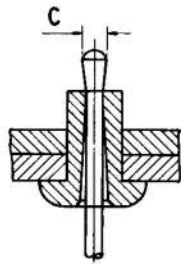

| RIVET DIA. | DIA. 'C' UNPINNED | DIA. 'C' PINNED |
|------------|-------------------|-----------------|
| 1/8        | 0.088             | 0.088           |
|            | 0.084             | 0.086           |
| 5/32       | 0.107             | 0.107           |
|            | 0.103             | 0.105           |

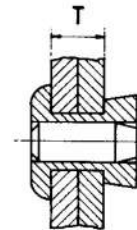

RIVET IN POSITION (PINNED)

INSPECTION DIMENSIONS FOR MANDREL DIAMETER

| DIA. 'D'  |                 | 1/8 DRILL - No. 30 |            |           | 5/32 DRILL - No. 21 |            |           |
|-----------|-----------------|--------------------|------------|-----------|---------------------|------------|-----------|
| TYPE      |                 | SNAP HEAD          | C'S'K HEAD | SHEAR PIN | SNAP HEAD           | C'S'K HEAD | SHEAR PIN |
| DIA. 'A'  |                 | 0.21               | 0.21       | —         | 0.25                | 0.25       | —         |
| DEPTH 'B' |                 | 0.039              | 0.025      | —         | 0.052               | 0.027      | —         |
| PART No.  | ALUMINIUM ALLOY | TK * SNA           | TK * CNA   | K * PD    | TL * SNA            | TL * CNA   | L * PD    |
|           | STEEL           | TK * SS            | TK * CS    | K * PS    | TL * SS             | TL * CS    | L * PS    |
| 'L'       | 'T' MAX.        | PART Nos.          |            |           |                     |            |           |
| 1/8       | 0.064           | 2                  | 2          | 2         | —                   | —          | —         |
| 1/16      | 0.125           | 3                  | —          | 3         | 3                   | —          | 3         |
|           |                 | —                  | 3          | 2         | —                   | 3          | 2         |
| 1/4       | 0.188           | 4                  | —          | 4         | 4                   | —          | 4         |
|           |                 | —                  | 4          | 3         | —                   | 4          | 3         |

NOTES

DIMENSIONS ARE IN INCHES

THE COMPLETE PART NUMBERS OF RIVETS CAN BE OBTAINED FROM TABLE. REPLACE \* BY THE NUMBER GIVEN REPRESENTING THE RIVET SIZE IN THE LOWER PART OF TABLE. THE PART NUMBER OF A 5/32 INCH DIAMETER ALUMINIUM ALLOY SNAP HEAD CHOBERT RIVET FOR JOINING A THICKNESS UP TO 0.125 IS TL-3-SNA.

ON EXTERNAL SURFACES RIVETS MUST BE FILLED WITH A NON-METALLIC FILLER SUCH AS I.C.I. GREY PUTTY REF. No. 147/524, OR WHERE SPECIFIED A SHEAR PIN OF SIMILAR MATERIAL TO THE RIVET SHOULD BE USED.

A REGULAR CHECK MUST BE MADE OF THE MANDREL HEAD TO ENSURE THAT IT HAS NOT WORN BELOW THE DIMENSION 'C' GIVEN IN SMALL TABLE. THIS IS PARTICULARLY IMPORTANT WHEN USING 'PINNED' RIVETS.

Fig.1/1A. Chobert rivet data sheet

RESTRICTED

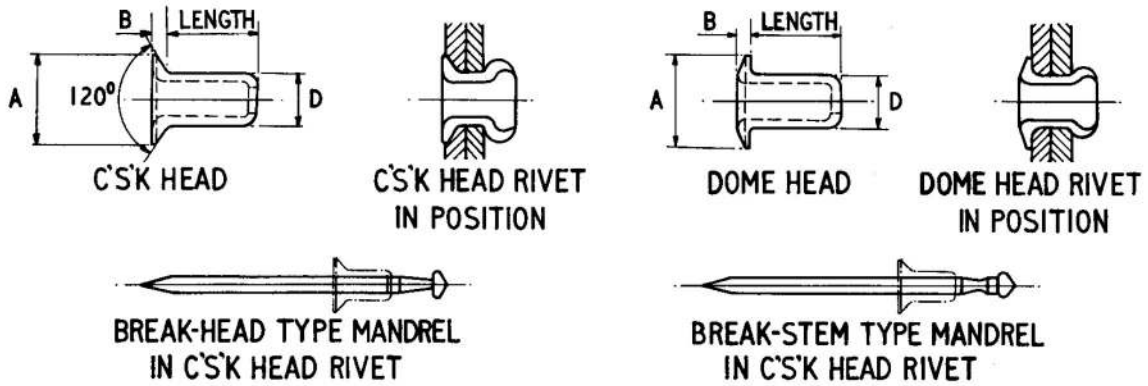

| 1/8 DIA. RIVETS - No 30 DRILL |              |           |                         |              |           |
|-------------------------------|--------------|-----------|-------------------------|--------------|-----------|
| DOME HEAD A.G.S. 2050         |              |           | C'S'K HEAD A.G.S. 2051  |              |           |
| DIA. 'A'                      |              | DEPTH 'B' | DIA. 'A'                |              | DEPTH 'B' |
| 0.236                         |              | 0.025     | 0.236                   |              | 0.036     |
| THICKNESS TO BE RIVETED       |              |           | THICKNESS TO BE RIVETED |              |           |
| BREAK-STEM                    | BREAK-HEAD   | CODE      | BREAK-STEM              | BREAK-HEAD   | CODE      |
| UP TO 0.03                    | UP TO 0.05   | 413       | UP TO 0.06              | UP TO 0.08   | 413       |
| 0.031 - 0.07                  | 0.051 - 0.09 | 419       | 0.061 - 0.10            | 0.081 - 0.12 | 419       |
| 0.071 - 0.12                  | 0.091 - 0.14 | 424       | 0.101 - 0.15            | 0.121 - 0.17 | 424       |
| 0.121 - 0.17                  | 0.141 - 0.19 | 429       | 0.151 - 0.20            | 0.171 - 0.22 | 429       |
| 0.171 - 0.23                  | 0.191 - 0.25 | 435       | 0.201 - 0.26            | 0.221 - 0.28 | 435       |
| 0.231 - 0.28                  | 0.251 - 0.30 | 440       | 0.261 - 0.31            | 0.281 - 0.33 | 440       |

| 5/32 DIA. RIVETS - No 21 DRILL |              |           |                         |              |           |
|--------------------------------|--------------|-----------|-------------------------|--------------|-----------|
| DOME HEAD A.G.S. 2050          |              |           | C'S'K HEAD A.G.S. 2051  |              |           |
| DIA. 'A'                       |              | DEPTH 'B' | DIA. 'A'                |              | DEPTH 'B' |
| 0.263                          |              | 0.028     | 0.263                   |              | 0.039     |
| THICKNESS TO BE RIVETED        |              |           | THICKNESS TO BE RIVETED |              |           |
| BREAK-STEM                     | BREAK-HEAD   | CODE      | BREAK-STEM              | BREAK-HEAD   | CODE      |
| UP TO 0.06                     | UP TO 0.08   | 519       | UP TO 0.09              | UP TO 0.11   | 519       |
| 0.061 - 0.12                   | 0.081 - 0.14 | 524       | 0.091 - 0.15            | 0.111 - 0.17 | 524       |
| 0.121 - 0.18                   | 0.141 - 0.20 | 530       | 0.151 - 0.21            | 0.171 - 0.23 | 530       |
| 0.181 - 0.23                   | 0.201 - 0.25 | 537       | 0.211 - 0.26            | 0.231 - 0.28 | 537       |
| 0.231 - 0.27                   | 0.251 - 0.29 | 540       | 0.261 - 0.30            | 0.281 - 0.32 | 540       |
| 0.271 - 0.32                   | 0.291 - 0.34 | 545       | 0.301 - 0.35            | 0.321 - 0.37 | 545       |

**NOTES**

DIMENSIONS ARE IN INCHES

THESE RIVETS MAY ONLY BE USED UNDER CONDITIONS DESCRIBED IN TEXT

ALL RIVET LENGTHS ARE MEASURED FROM UNDER THE HEAD

**KEY TO RIVET CODE NUMBERS**

FIRST DIGIT SHOWS DIAMETER IN 1/32 OF AN INCH. SECOND AND THIRD DIGITS SHOW LENGTH UNDER HEAD IN 1/100 OF AN INCH

B.S. SUFFIX FOR BREAK-STEM MANDREL

B.H. SUFFIX FOR BREAK-HEAD MANDREL

**METHOD OF CALLING UP**

FROM THE ABOVE TABLES THE PART NUMBER OF 1/8 INCH DIAMETER DOME HEAD RIVETS WITH BREAK-STEM MANDREL FOR JOINING A THICKNESS OF 0.08 IS A.G.S. 2050/424/B.S.

Fig.1/1B. Pop rivet data sheet

**RESTRICTED**

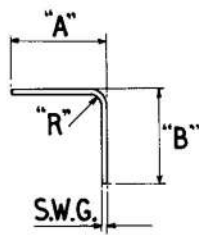

| SECTN N <sup>o</sup> | "A"            | "B"            | "R"           | S.W.G. | SPECN      |
|----------------------|----------------|----------------|---------------|--------|------------|
| J.261                | <sup>50</sup>  | <sup>50</sup>  | <sup>06</sup> | 22     | D.T.D. 610 |
| J.600                | <sup>225</sup> | <sup>225</sup> | <sup>32</sup> | 14     | D.T.D. 546 |
| J.601                | <sup>40</sup>  | <sup>40</sup>  | <sup>04</sup> | 26     | D.T.D. 610 |
| J.617                | <sup>75</sup>  | <sup>60</sup>  | <sup>06</sup> | 22     | D.T.D. 610 |

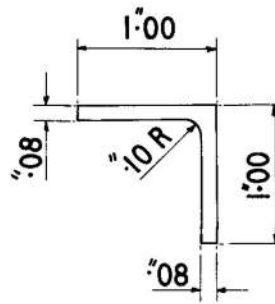

SPECN D.T.D. 423

J.616

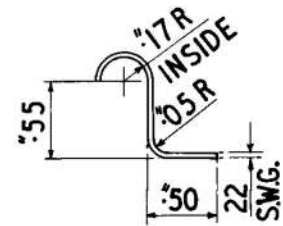

SPECN D.T.D. 610

J.604

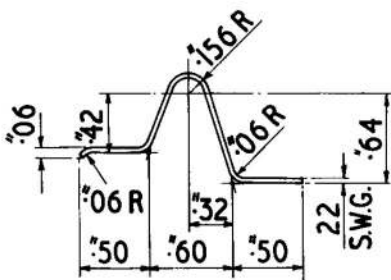

SPECN D.T.D. 610

J.621

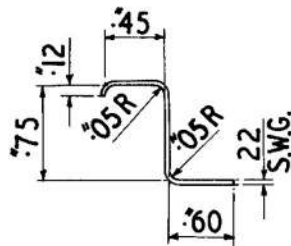

SPECN D.T.D. 610

REPAIR SECTION  
J.516

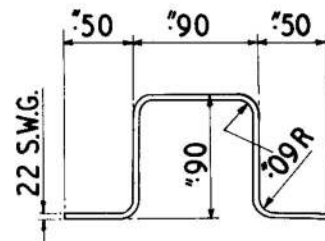

SPECN D.T.D.610

J.602

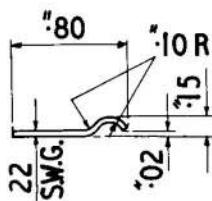

SPECN D.T.D. 610

J.608

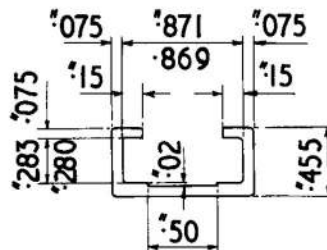

SPECN D.T.D.423

J.615

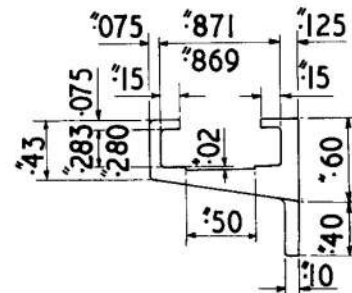

SPECN D.T.D. 423

J.614

Fig.1/2. Standard sections

**RESTRICTED**

This file was downloaded  
from the RTFM Library.

Link: [www.scottbouch.com/rtfm](http://www.scottbouch.com/rtfm)

Please see site for usage terms,  
and more aircraft documents.

