

**CHAPTER 3**

**SYSTEMS**

CHAP.

**3**

**R E S T R I C T E D**

Chapter 3

SYSTEMS

List of contents

	Para.		Para.
Piping ... ..	1	Oil tank ... ..	3
Fuel tanks ... ..	2		

Illustration

	Fig.
Repair of tanks ... ..	3/1

<p><b>Piping</b></p> <p>1. All piping in both the fuel and oil systems should be renewed if damaged.</p> <p><b>Fuel tanks</b></p> <p>2. The flexible tanks are repairable in accordance with the methods published in A. P. 4117A, Vol. 1 and Vol. 2, Part 3.</p>	<p><b>Oil tank</b></p> <p>3. Holes of any size can be repaired as shown in fig. 3/1. When repairing damage it will be necessary first to remove the cooler which can be done by removing the bolts at both ends thereby breaking the joints and enabling the withdrawal of the cooler through the end opposite the filler cap. When refitting, new gaskets must be used.</p>
--	--

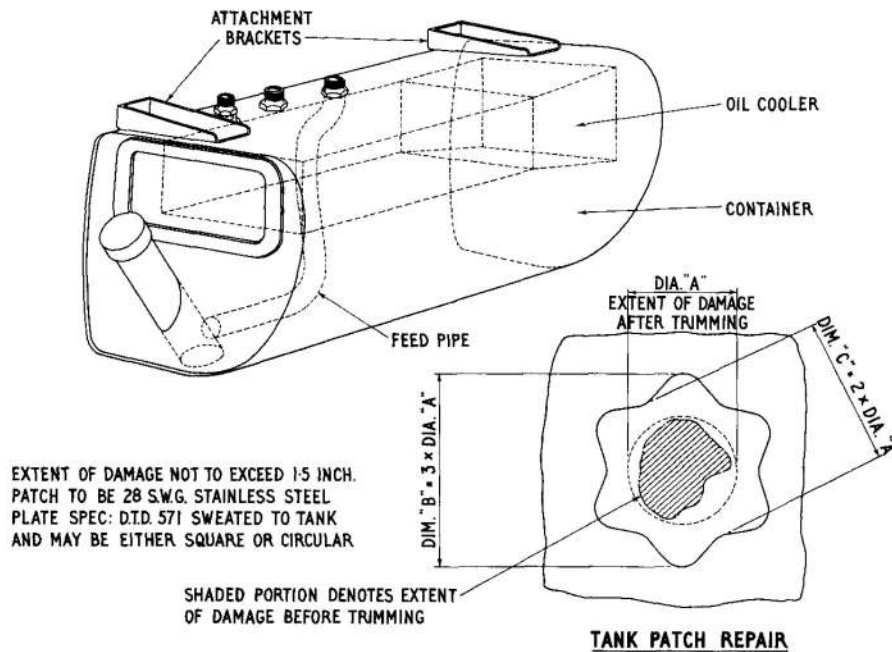

Fig. 3/1. Repair of tanks

**RESTRICTED**

This file was downloaded  
from the RTFM Library.

Link: [www.scottbouch.com/rtfm](http://www.scottbouch.com/rtfm)

Please see site for usage terms,  
and more aircraft documents.

