

CHAPTER 5

ALIGHTING GEAR

CHAP.

5

R E S T R I C T E D

Chapter 5
ALIGHTING GEAR

List of contents

	Para.
Description	1
Definitions of negligible and repairable damage	2

Illustration

	Fig.
Alighting gear	5/1

Description

1. The alighting gear consists of two single wheel non-retractable cantilever undercarriages and a fully castoring tail wheel. The main wheels have hydraulically operated brakes and a skid may be substituted for the tail wheel in certain circumstances. A housing for each undercarriage leg is mounted within the "D" nose assembly of each wing, especially heavy ribs being provided

at this location.

Definitions of negligible and repairable damage

2. Damage defined as negligible will be found in Table 1. Certain items may be reclaimed by fitting of over-size bushes as defined in Chapter 9. Otherwise damaged parts must be renewed or application made for a suitable repair.

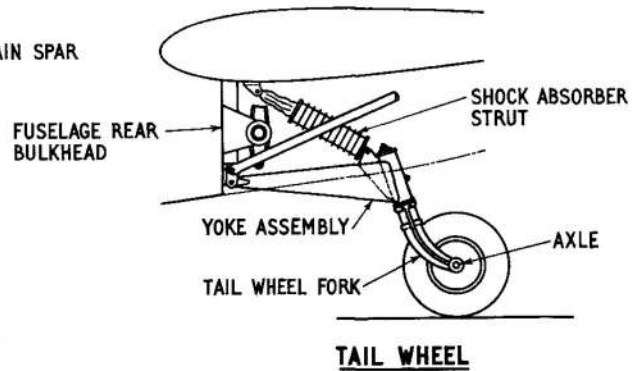
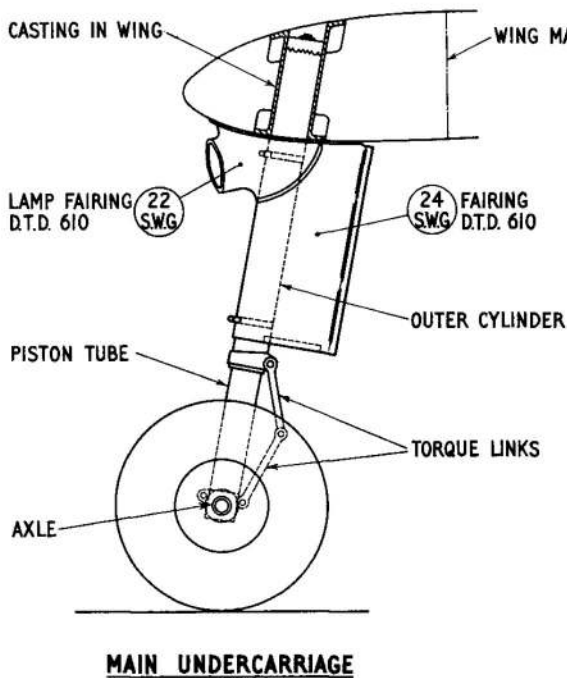

Fig. 5/1. Alighting gear

RESTRICTED

Table 1

Negligible damage definitions

Component	Definition	Remarks
MAIN UNDERCARRIAGE		
Outer cylinder	Scores or abrasions 0.006 in. deep, 1.0 in. long around the circumference or 3.0 in. along the cylinder.	
Piston tube	Scores or scratches 0.006 in. deep and 2.0 in. along the tube.	No scores <u>round</u> circumference can be treated as negligible.
Torque links	Scores or abrasions 0.05 in. deep, less than 0.5 sq. in. in area and at least 1.5 in. from bolt holes.	
Leg and lamp fairings	Small damage can be treated as negligible.	When damaged seriously and pending replacement these items can be omitted from the aircraft
TAIL WHEEL		
Yoke assembly	Scores or abrasions 0.005 in. deep and less than 0.5 sq. in. in area.	
Fork (steel tube type)	Scores or abrasions 0.005 in. deep and not greater than 0.1 sq. in. in area.	
(forged type)	Scores or abrasions 0.05 in. deep and less than 0.25 sq. in. in area.	

RESTRICTED

This file was downloaded
from the RTFM Library.
Link: www.scottbouch.com/rtfm
Please see site for usage terms,
and more aircraft documents.

